

Features

- DC ~ 1200 MHz, 50 Ω Application
- For 30 ~ 860 MHz 50 Ω Matching @ V_{device} = +10 V, I_{dd} = 300 mA:
- 22.8 dB Gain at 500 MHz
- 30 dBm OP1dB
- 45.5 dBm Output IP3
- 2.2 dB NF

Typical Performance

(Supply Voltage = +10 V, T_A = +25 °C, Z₀ = 50 Ω)

| Parameters | Units | Typical | | | |
|--------------------------|-------|---------|------|------|------|
| Frequency | MHz | 30 | 50 | 500 | 860 |
| Gain | dB | 22.2 | 22.5 | 22.8 | 22.5 |
| S11 | dB | -12 | -13 | -20 | -10 |
| S22 | dB | -10 | -11 | -17 | -10 |
| Output IP3 ¹⁾ | dBm | 47.0 | 47.5 | 45.5 | 45.0 |
| Noise Figure | dB | 1.7 | 1.8 | 2.2 | 2.1 |
| Output P1dB | dBm | 27.0 | 29.0 | 30.0 | 30.5 |
| Current | mA | 300 | 300 | 300 | 300 |
| Device Voltage | V | +10 | +10 | +10 | +10 |

1) OIP3 is measured with two tones at an output power of +15 dBm/tone separated by 1 MHz.

Product Specifications

| Parameters | Units | Min | Typ. | Max |
|-------------------|-------|-----|------|-----|
| Testing Frequency | MHz | | 500 | |
| Gain | dB | | 22.8 | |
| S11 | dB | | -20 | |
| S22 | dB | | -17 | |
| Output IP3 | dBm | | 45.5 | |
| Noise Figure | dB | | 2.2 | |
| Output P1dB | dBm | | 30.0 | |
| Current | mA | | 300 | |
| Device Voltage | V | | +10 | |

Absolute Maximum Ratings

| Parameters | Rating |
|--------------------------------|----------------|
| Operating Case Temperature | -40 to +85 °C |
| Storage Temperature | -40 to +150 °C |
| Device Voltage | +13 V |
| Operating Junction Temperature | +150 °C |
| Input RF Power (Continuous) | +22 dBm |
| Thermal Resistance | +14 °C/W |

* Please find the max. input power data from http://www.asb.co.kr/pdf/Maximum_Input_Power_Analysis.pdf



Package Style: SOIC8

Applications

- Wide Band
(30 ~ 860 MHz, 10 V, 300 mA)
- Wide Band
(30 ~ 860 MHz, 12 V, 291 mA)
- IF
(200 ~ 400 MHz, 10 V, 320 mA)
- IF
(0.3 ~ 30 MHz, 9 V, 160 mA)
- IF
(20 ~ 1000 MHz, 11 V, 283 mA)

Pin Configuration

| Pin No. | Function |
|-----------|--------------------|
| 1,3,5,6,8 | NC or GND |
| 2 | RF IN |
| 7 | RF OUT |
| 4 | Current Adjustable |

Outline Drawing

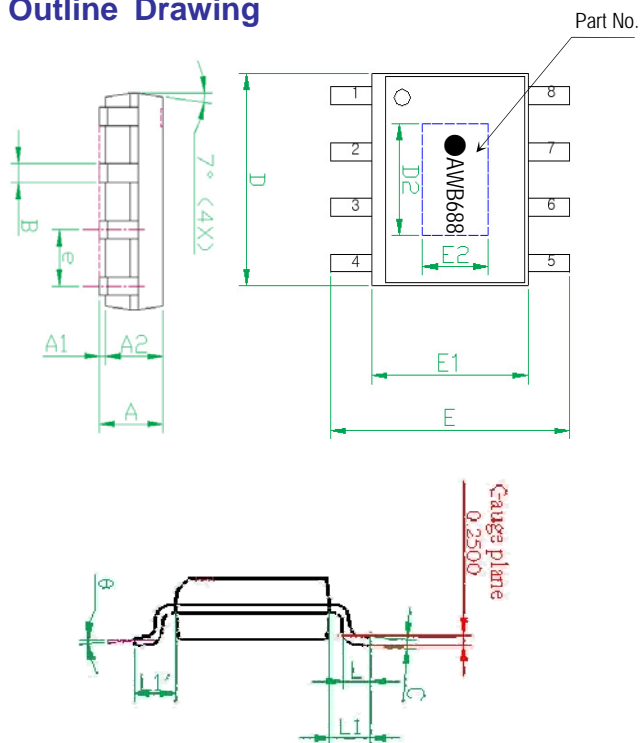

| Symbols | Dimensions (In mm) | | |
|---------|--------------------|------|------|
| | MIN | NOM | MAX |
| A | 1.40 | 1.50 | 1.60 |
| A1 | 0.00 | --- | 0.10 |
| A2 | --- | 1.45 | --- |
| B | 0.33 | --- | 0.51 |
| C | 0.19 | --- | 0.25 |
| D | 4.80 | --- | 5.00 |
| D2 | 3.20 | 3.30 | 3.40 |
| E | 5.80 | 6.00 | 6.20 |
| E1 | 3.80 | 3.90 | 4.00 |
| E2 | 2.30 | 2.40 | 2.50 |
| e | --- | 1.27 | --- |
| L | 0.40 | --- | 1.27 |
| y | --- | --- | 0.10 |
| θ | 0° | --- | 8° |
| L1-L1' | --- | --- | 0.12 |
| L1 | 1.04REF | | |

| Pin No. | Function | Pin No. | Function. |
|---------|--------------------|---------|-----------|
| 1 | NC or GND | 5 | NC or GND |
| 2 | RF IN | 6 | NC or GND |
| 3 | NC or GND | 7 | RF OUT |
| 4 | Current Adjustable | 8 | NC or GND |

Note: 1. Backside metal paddle is RF and DC ground.

Mounting Recommendation (In mm)

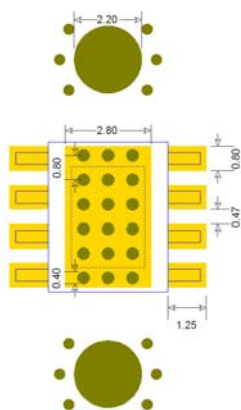

- Note:**
1. Add as much copper as possible to inner and outer layers near the part to ensure optimal thermal performance.
 2. To ensure reliable operation, device ground paddle-to-ground pad soldering is critical.
 3. Add mounting screws near the part to fasten the board to a heat sink. Ensure that the ground / thermal via region contacts the heat sink.
 4. A proper heat dissipation path underneath the area of the PCB for the mounted device is strictly required for proper thermal operation. Damage to the device can result from inappropriate heat dissipation.

ESD Classification

| | |
|-----|---|
| HBM | Class 1B Voltage Level: 500 V~1000 V |
| MM | Class A Voltage Level: <200 V |

CAUTION: ESD-sensitive device!

Moisture Sensitivity Level (MSL)

Level 3 at 260°C reflow

DC ~ 1500 MHz Wideband MMIC Amplifier

APPLICATION CIRCUIT

Wide Band
30 ~ 860 MHz
+10 V

| Frequency (MHz) | 30 | 50 | 500 | 860 |
|--------------------------------|------|------|------|------|
| Magnitude S21 (dB) | 22.2 | 22.5 | 22.8 | 22.5 |
| Magnitude S11 (dB) | -12 | -13 | -20 | -10 |
| Magnitude S22 (dB) | -10 | -11 | -17 | -10 |
| Output P1dB (dBm) | 27.0 | 29.0 | 30.5 | 30.0 |
| Output IP3 ¹⁾ (dBm) | 47.0 | 47.5 | 45.5 | 45.0 |
| Noise Figure (dB) | 1.7 | 1.8 | 2.2 | 2.1 |
| Device Voltage (V) | +10 | +10 | +10 | +10 |
| Current (mA) | 300 | 300 | 300 | 300 |

1) OIP3 is measured with two tones at an output power of +15 dBm/tone separated by 1 MHz.

Schematic

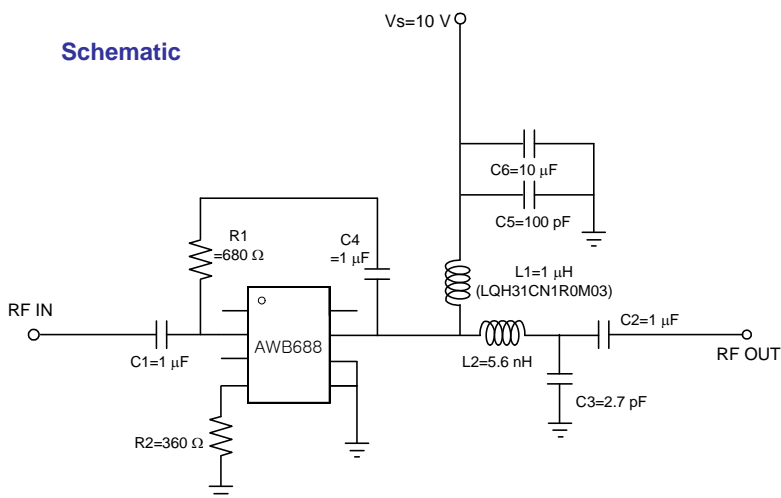

Board Layout (FR4, 40x40 mm², 0.8T)

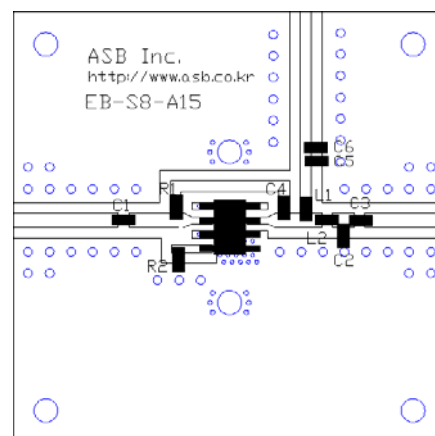

S-parameters & K-factor

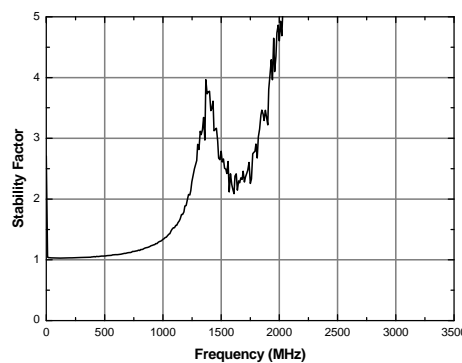
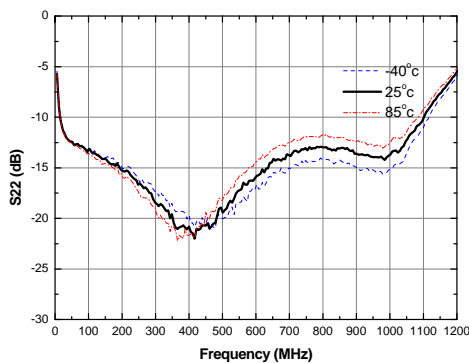
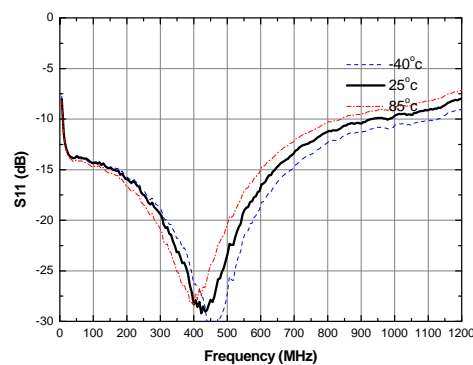
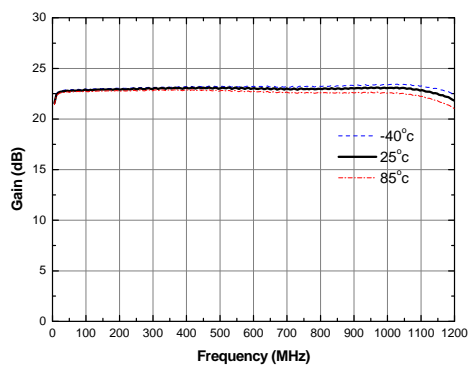

Current vs. Temperature

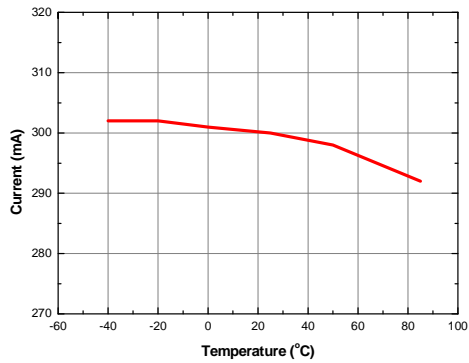

Gain vs. Temperature

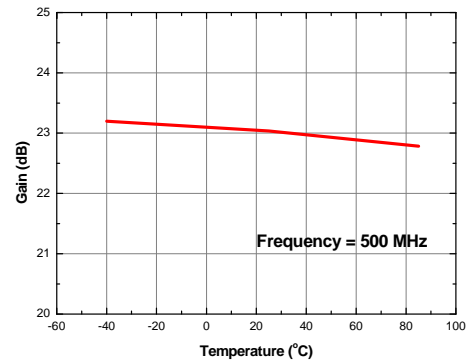

P1dB vs. Temperature

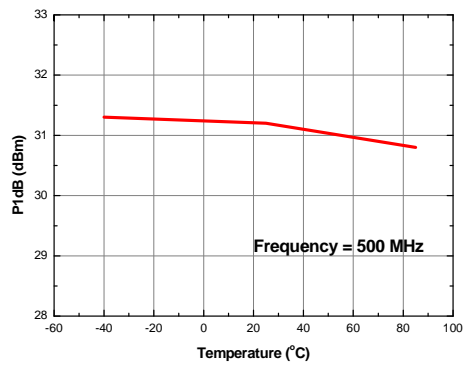

Output IP3 vs. Tone Power (Frequency = 500 MHz)

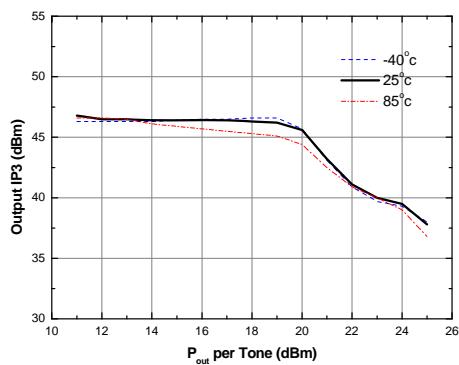

APPLICATION CIRCUIT

Wide Band
30 ~ 860 MHz
+12 V

| Frequency (MHz) | 30 | 50 | 500 | 860 |
|--------------------------------|------|------|-------|------|
| Magnitude S21 (dB) | 22.5 | 22.5 | 22.0 | 22.6 |
| Magnitude S11 (dB) | -14 | -13 | -17 | -10 |
| Magnitude S22 (dB) | -12 | -12 | -20.3 | -11 |
| Output P1dB (dBm) | 30.0 | 31.0 | 31.5 | 30.5 |
| Output IP3 ¹⁾ (dBm) | 47 | 46 | 43 | 43 |
| Noise Figure (dB) | 1.6 | 1.6 | 1.9 | 2.0 |
| Device Voltage (V) | +12 | +12 | +12 | +12 |
| Current (mA) | 291 | 291 | 291 | 291 |

1) OIP3 is measured with two tones at an output power of +15 dBm/tone separated by 1 MHz.

Schematic

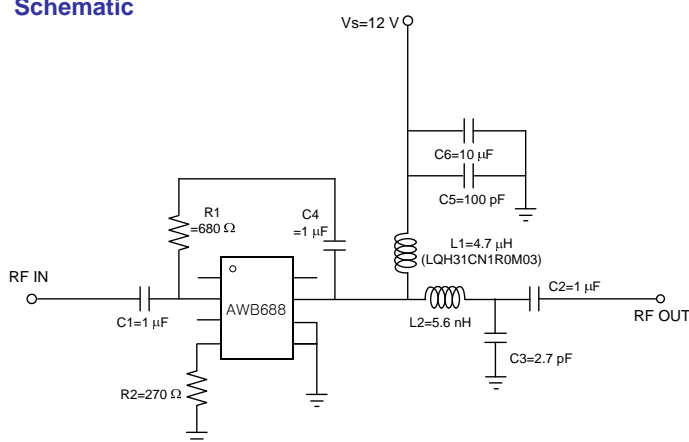

Board Layout (FR4, 40x40 mm², 0.8T)

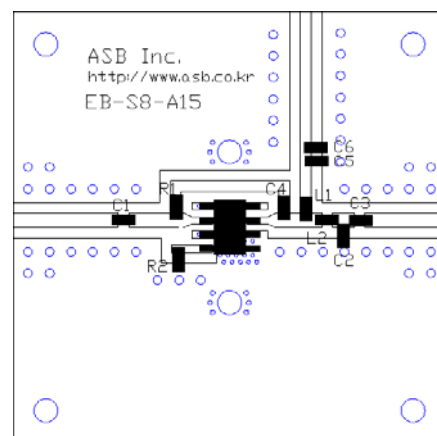

S-parameters & K-factor

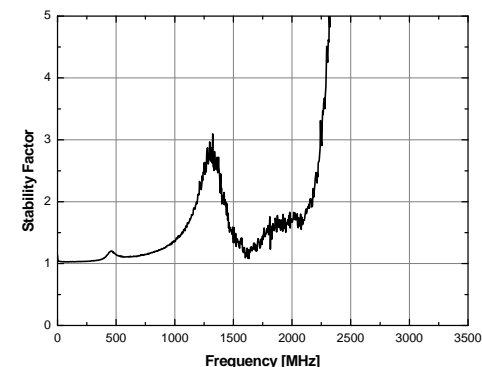
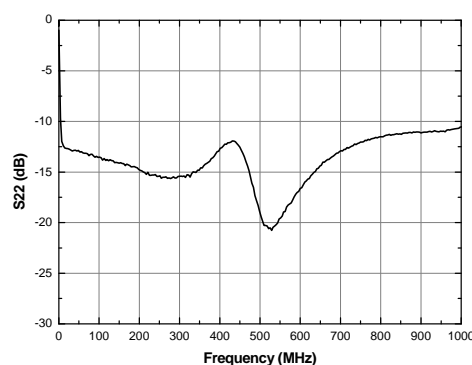
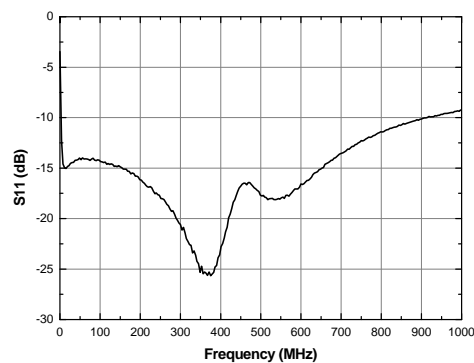
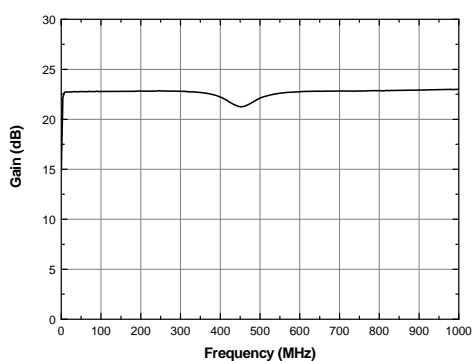

APPLICATION CIRCUIT

IF
200 ~ 400 MHz
+10 V

| Frequency (MHz) | 200 | 400 |
|--------------------------------|-------|-------|
| Magnitude S21 (dB) | 22.7 | 22.8 |
| Magnitude S11 (dB) | -15.0 | -22.0 |
| Magnitude S22 (dB) | -15.0 | -22.0 |
| Output P1dB (dBm) | 31.0 | 31.0 |
| Output IP3 ¹⁾ (dBm) | 48.0 | 47.0 |
| Noise Figure (dB) | 2.0 | 1.8 |
| Device Voltage (V) | +10 | +10 |
| Current (mA) | 320 | 320 |

1) OIP3 is measured with two tones at an output power of +15 dBm/tone separated by 1 MHz.

Schematic

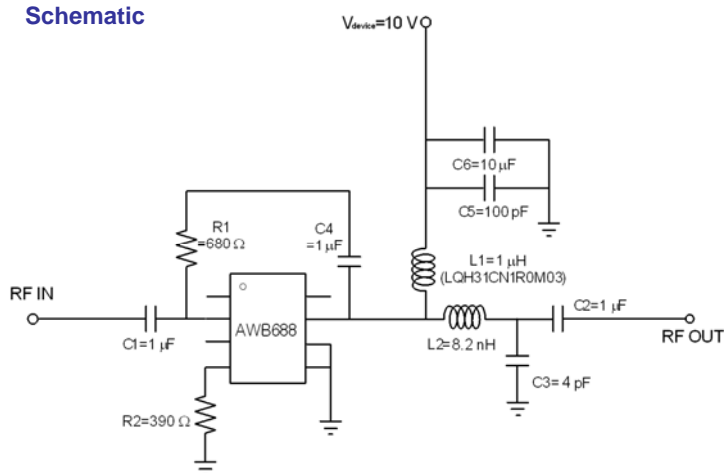

Board Layout (FR4, 40x40 mm², 0.8T)

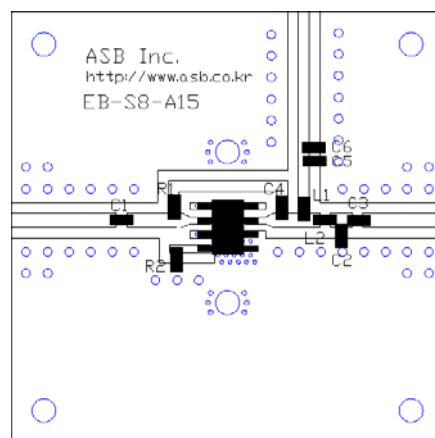

S-parameters & Noise Figure

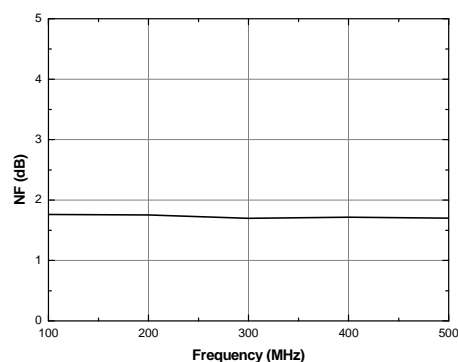
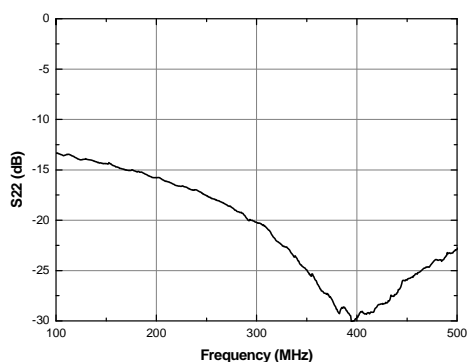
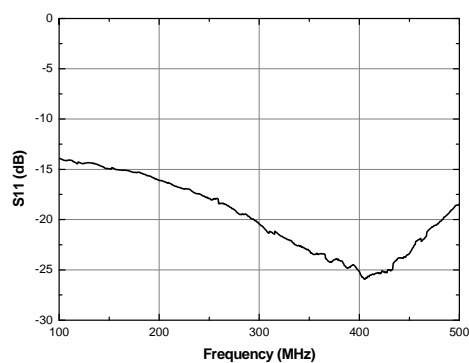
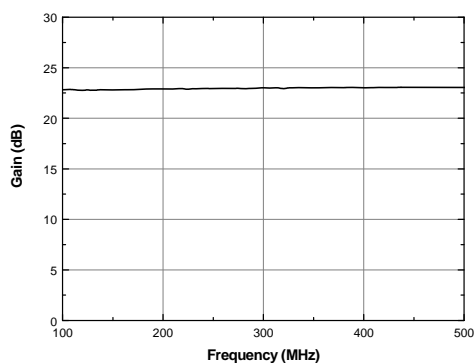

APPLICATION CIRCUIT

IF
 0.3 ~ 30 MHz
 +9 V

| Frequency (MHz) | 0.3 | 30 |
|--------------------------------|------|------|
| Magnitude S21 (dB) | 23 | 23 |
| Magnitude S11 (dB) | -21 | -20 |
| Magnitude S22 (dB) | -15 | -16 |
| Output P1dB (dBm) | 25.5 | 27.0 |
| Output IP3 ¹⁾ (dBm) | - | 44 |
| Noise Figure (dB) | 1.6 | 1.5 |
| Device Voltage (V) | +9 | +9 |
| Current (mA) | 160 | 160 |

1) OIP3 is measured with two tones at an output power of +12 dBm/tone separated by 1 MHz.

Schematic

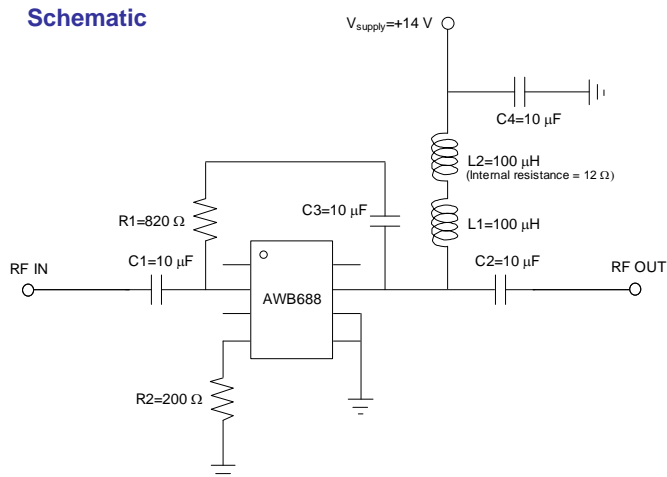

Board Layout (FR4, 40x40 mm², 0.8T)

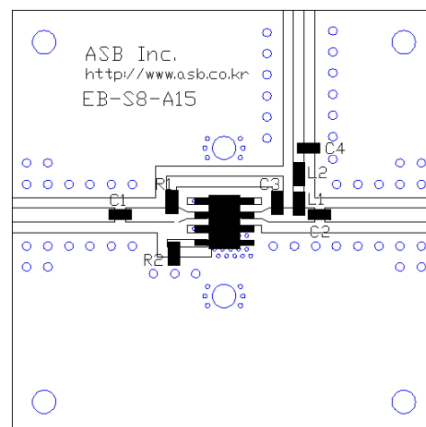

S-parameters

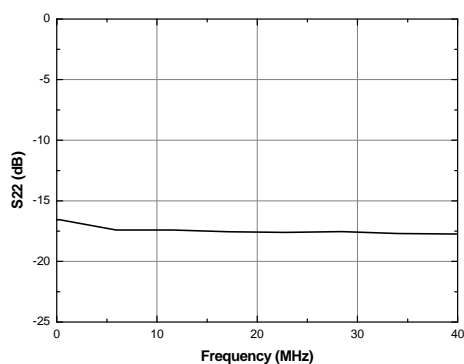
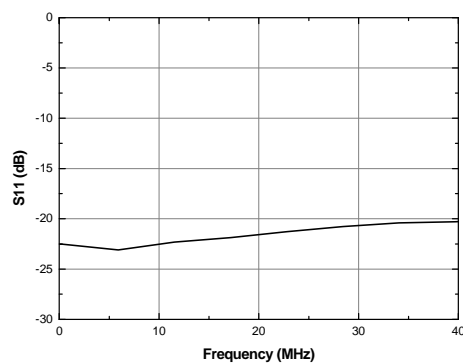
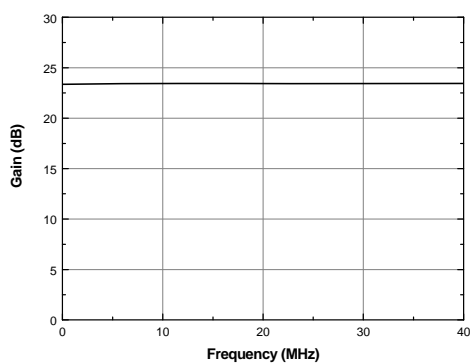

APPLICATION CIRCUIT

IF

20 ~ 1000 MHz

+11 V

| Frequency (MHz) | 20 | 500 | 1000 |
|--------------------------------|------|------|------|
| Magnitude S21 (dB) | 22.3 | 23.0 | 23.3 |
| Magnitude S11 (dB) | -12 | -21 | -8 |
| Magnitude S22 (dB) | -10 | -17 | -9 |
| Output P1dB (dBm) | 27.5 | 31.5 | 29.0 |
| Output IP3 ¹⁾ (dBm) | 49.0 | 45.0 | 42.3 |
| Output IP2 ¹⁾ (dBm) | 65 | 48 | 60 |
| Noise Figure (dB) | 1.5 | 1.8 | 2.0 |
| Device Voltage (V) | +11 | +11 | +11 |
| Current (mA) | 283 | 283 | 283 |

1) OIP3 & OIP2 is measured with two tones at an output power of +15 dBm/tone separate-ed by 1 MHz.

Schematic

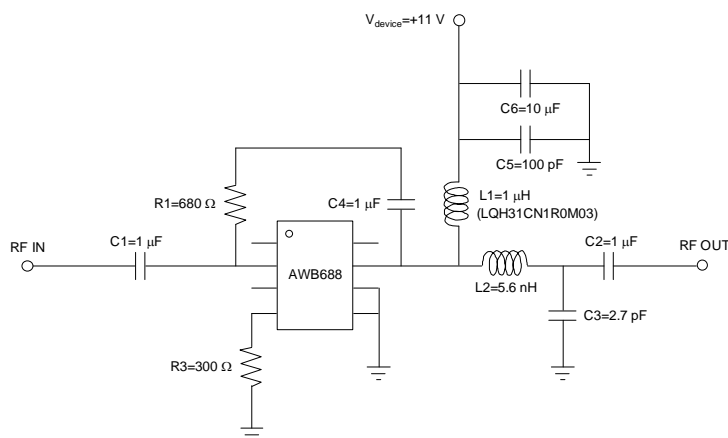

Board Layout (FR4, 40x40 mm², 0.8T)

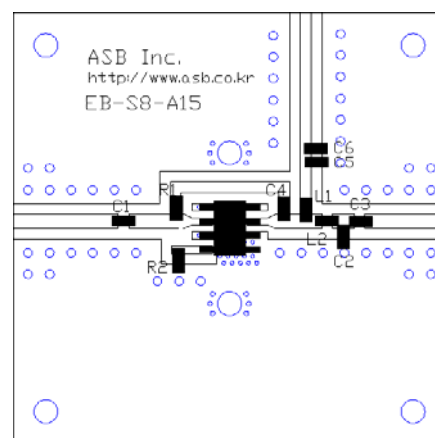

S-parameters & K-factor

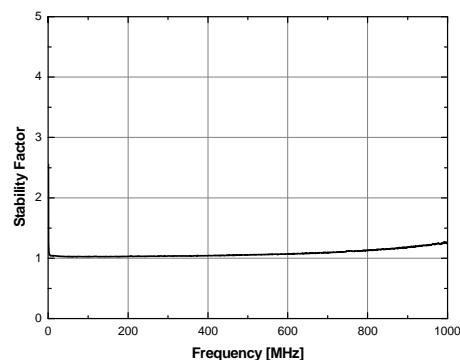
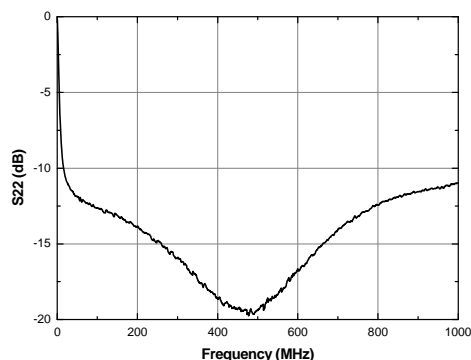
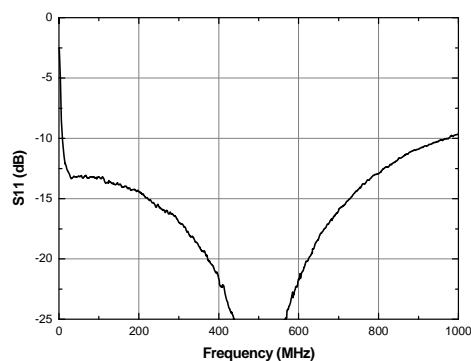
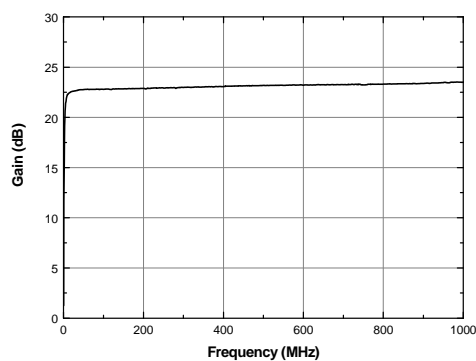

Device Voltage and Current for Different Values of R2

| Device Voltage (V) | +8 | +9 | +10 | +11 | +12 |
|----------------------------|--------------|-----|-----|-----|-----|
| R2 Resistance (Ω) | Current (mA) | | | | |
| 240 | 159 | 184 | 208 | 232 | 257 |
| 270 | 177 | 204 | 231 | 258 | 283 |
| 300 | 195 | 225 | 254 | 283 | 310 |
| 330 | 215 | 247 | 278 | 309 | 336 |
| 360 | 231 | 265 | 300 | 331 | 357 |
| 390 | 247 | 283 | 318 | 348 | 371 |
| 430 | 271 | 309 | 344 | 373 | 394 |
| 470 | 292 | 333 | 368 | 394 | |
| 510 | 313 | 354 | 389 | | |
| 560 | 339 | 381 | | | |
| 620 | 367 | | | | |