



AWS5508

SP4T PHEMT

Transmit/Receive Antenna Switch

GSM 900 MHz/DCS 1800 MHz/PCS 1900 MHz

ADVANCED PRODUCT INFORMATION - Rev 0.3

FEATURES

- 2.7V Control Operation
- Tri-band Operation
- High Isolation
- High Power
- High Linearity
- Small Leadless Package

APPLICATIONS

- SP4T Antenna switch operating in the GSM 900 MHz, DCS 1800 MHz, and PCS 1900 MHz bands

PRODUCT DESCRIPTION

The AWS5508 SP4T high power antenna switch is designed to operate in the GSM 900MHz, DCS 1800MHz, and PCS 1900MHz frequency bands. All 4 ports of the switch have identical electrical and linearity performance which allows flexibility in system design. Switching between ports is accomplished using 2.7 to 6 volts differential control voltages on the 4 control pins. The switch is provided in a leadless MLP-16 quad flat package.

1. DC blocking capacitors C_b and optional resistor R_s must be supplied externally.
2. $C_b = 100\text{ pF}$ for operation $>500\text{MHz}$.
3. The use of resistor R_s to the positive voltage supply is optional. It is only required if it is necessary to have all RF ports in Isolation state at the same time. Also, using R_s will improve linearity performance to a small degree when V_{CTL} is at its lower limit. $R_s = 10\text{k}\Omega$ when used.

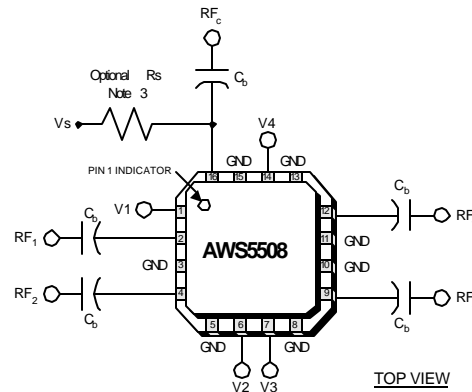

Figure 1: Pin Out Diagram

Table 1: Pin Description

PIN	NAME	DESCRIPTION	PIN	NAME	DESCRIPTION
1	V1	Control for RF1 , pin 2.	9	RF3	RF port, controlled by V3.
2	RF1	RF port, controlled by V1.	10	GND	Ground connection, keep short as possible.
3	GND	Ground connection, keep short as possible.	11	GND	Ground connection, keep short as possible.
4	RF2	RF port, controlled by V2.	12	RF4	RF port, controlled by V4.
5	GND	Ground connection, keep short as possible.	13	GND	Ground connection, keep short as possible.
6	V2	Control for RF2, pin 4.	14	V4	Control for RF4, pin 12.
7	V3	Control for RF3, pin 9.	15	GND	Ground connection, keep short as possible.
8	GND	Ground connection, keep short as possible.	16	RFc	Common RF Port.

08/2001

AWS5508

ELECTRICAL CHARACTERISTICS

Table 2: Absolute Minimum and Maximum Ratings

PARAMETER	MIN	MAX	UNIT
RF Input Power > 500 MHz, VCTL = 2.7V	-	8	W
Control Voltage	-0.4	10	V
Operating Temperature	-40	+125	°C
Storage Temperature	-65	+150	°C

Stresses in excess of the absolute ratings may cause permanent damage. Functional operation is not implied under these conditions. Exposure to absolute ratings for extended periods of time may adversely affect reliability.

Notes:

- Control Voltage is the differential voltage between any of pins V1, V2, V3, V4 and RFc.

Table 3: Operating Ranges at 25° C

PARAMETER	CONDITION	FREQUENCY	MIN	TYP	MAX	UNIT
Switching Characteristics	Rise, Fall (10/90% or 90/10% RF)			100		ns
	On, Off (50% CTL to 90%/10% RF)			100		ns
	Video Feedthru			50		mV
Intermodulation Intercept Point (IP3)	2 tone power levels 13dBm to 27dBm (selected to optimize dynamic range of test)	1.0 GHz	+48	+51		dBm
		1.8 GHz	+48	+51		dBm
	V _{CTL} = 2.7V	1.0 GHz	+56	+59		dBm
		1.8 GHz	+56	+60		dBm
Control Voltage (VCTL) ³			2.7		6	V
Leakage Current	V _{CTL} = 2.7V			>5	50	μA
	V _{CTL} = 5.0V			>10	100	μA

The device may be operated safely over these conditions; however, parametric performance is guaranteed only over the conditions defined in the electrical specifications.

Notes:

- All measurements made in a broadband 50 Ω system.
- Video feedthru measured with 1 ns risetime pulse and 500MHz bandwidth.
- VCTL is the differential voltage between any one of the control pins (V1 through V4) and the remaining three control pins. Changing which control pin is the most positive voltage selects the switch path as defined in the truth table below. Use of the optional resistor Rs on the common port limits VHigh to Vs ± 0.2V.

AWS5508

Table 4: Electrical Specifications at 25 °C ($V_{CTL} = 2.7V$)

PARAMETER	CONDITION	FREQUENCY	MIN	TYP	MAX	UNIT
Insertion Loss	$P_N = +34dBm$	0.5 - 1.0 GHz		0.65	0.8	dB
		1.0 - 2.0 GHz		0.90	1.0	dB
Isolation	$P_N = +34dBm$	0.5 - 1.0 GHz	22	25		dB
		1.0 - 2.0 GHz	18	21		dB
VSWR	In Low Loss Path	0.5 - 2.0 GHz		1.20:1	1.35:1	

Table 5: Harmonics

CONTROL VOLTAGE (V_{CTL})	HARMONIC LEVEL (DBC) TYP. ⁽¹⁾			
	1000MHz, Pin = +34dBm		2000MHz, Pin = +34dBm	
	2nd	3rd	2nd	3rd
2.7V	-58	-61	-59	-60
4.7V	-63	-64	-61	-63

1. Measured in broadband 50Ω system

Table 6: Functional Truth Table

V1	V2	V3	V4	RFc ↔ RF1	RFc ↔ RF2	RFc ↔ RF3	RFc ↔ RF4
V _{HIGH}	V _{LOW}	V _{LOW}	V _{LOW}	Low Loss	Isolation	Isolation	Isolation
V _{LOW}	V _{HIGH}	V _{LOW}	V _{LOW}	Isolation	Low Loss	Isolation	Isolation
V _{LOW}	V _{LOW}	V _{HIGH}	V _{LOW}	Isolation	Isolation	Low Loss	Isolation
V _{LOW}	V _{LOW}	V _{LOW}	V _{HIGH}	Isolation	Isolation	Isolation	Low Loss

$V_{CTL} = V_{HIGH} - V_{LOW} = +2.5V$ to $+8V$ ($V_{HIGH} = V_s \pm 0.2V$ when R_s is used on RFc port.)

AWS5508

PERFORMANCE DATA

Figure 2: Insertion Loss vs. Frequency

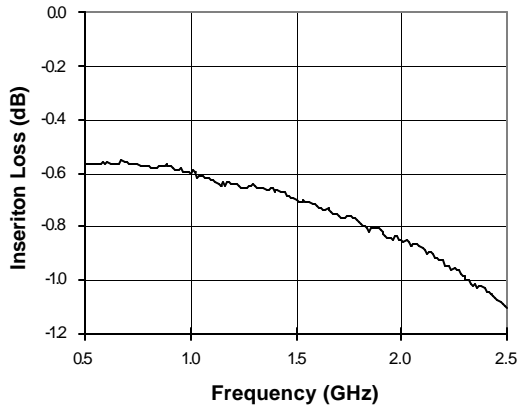

Figure 3: Isolation vs. Frequency

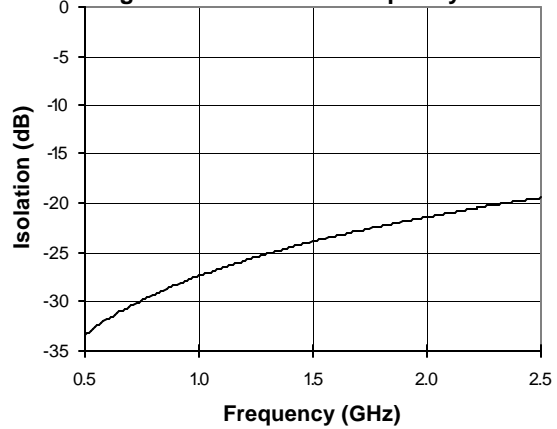

Figure 4: Return Loss vs. Frequency

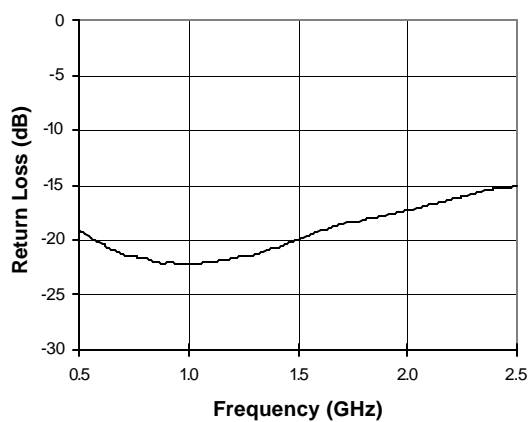

Figure 5: TOI vs. Control Voltage

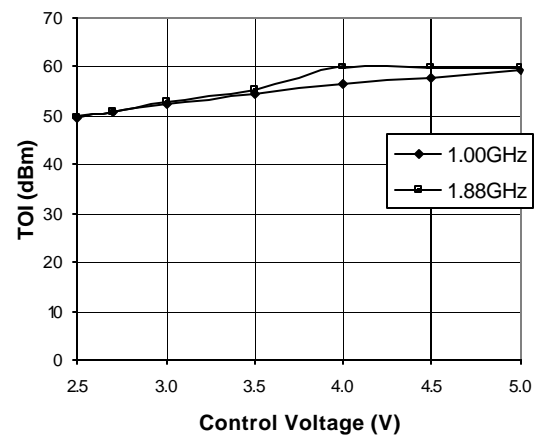

Figure 6: 2nd and 3rd Harmonic Levels vs. Control Voltage at 1.0 GHz @ +34dBm

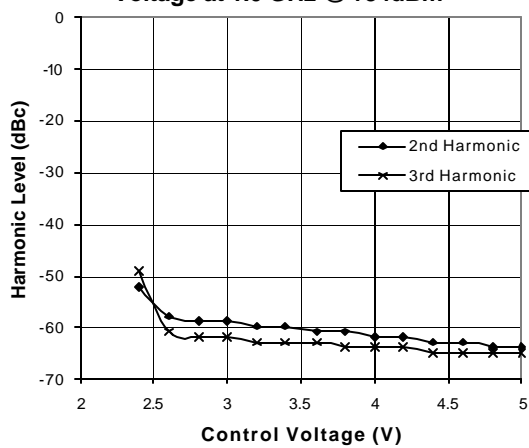
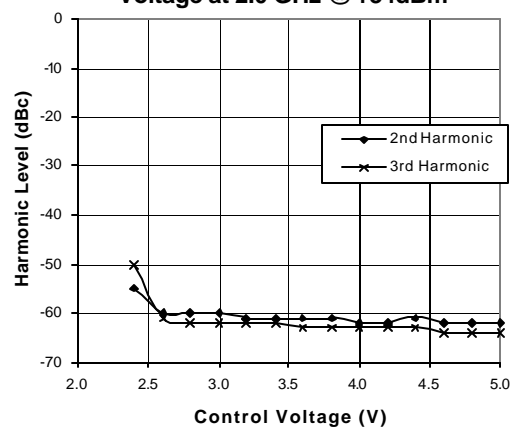
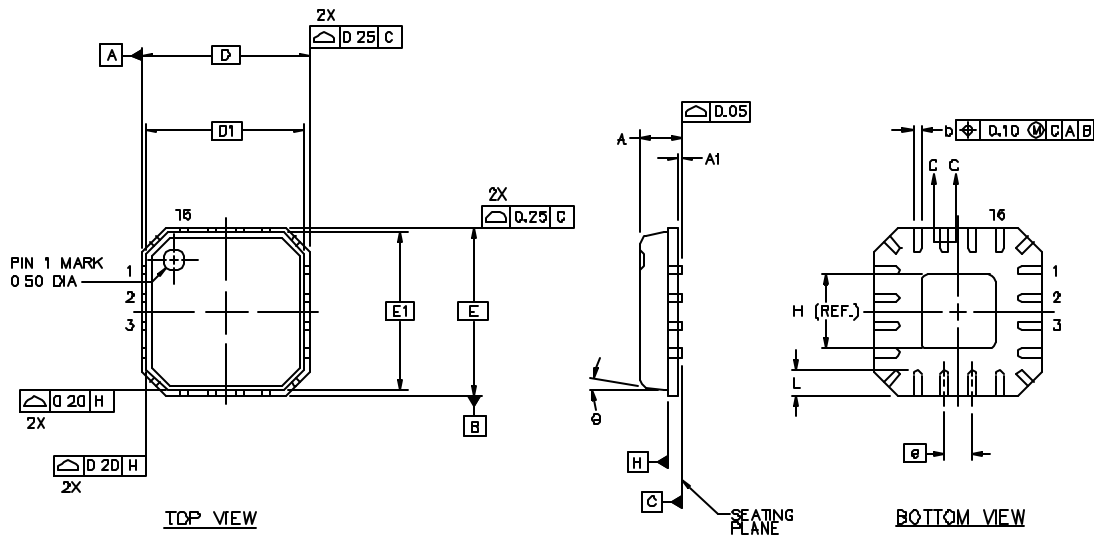

Figure 7: 2nd and 3rd Harmonic Levels vs. Control Voltage at 2.0 GHz @ +34dBm



AWS5508

PACKAGE OUTLINE



DIMENSIONS—MM				DIMENSIONS—INCHES			
	MIN.	NOM.	MAX.		MIN.	NOM.	MAX.
A		0.85	1.00	A		0.033	0.039
A1	0.010	0.01	0.05	A1	0.000	0.0004	0.002
b	0.23	0.28	0.35	b	0.009	0.011	0.014
D		4.00 BSC		D		0.157 BSC	
D1		3.75 BSC		D1		0.147 BSC	
E		4.00 BSC		E		0.157 BSC	
E1		3.75 BSC		E1		0.147 BSC	
e		0.65 BSC		e		0.025 BSC	
L	0.50	0.80	0.75	L	0.019	0.023	0.029
g			12°	g			12°
H		1.70 (REF.)		H		0.067 (REF.)	

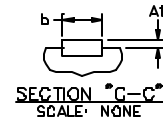

Figure 8: Package Outline Drawing

AWS5508
NOTES

AWS5508

NOTES

AWS5508**ORDERING INFORMATION**

ORDER NUMBER	PACKAGE DESCRIPTION	COMPONENT PACKAGING
AWS5508S19	S19	Multipin Leadless Plastic Package

**ANADIGICS, Inc.**

141 Mount Bethel Road
 Warren, New Jersey 07059, U.S.A
 Tel: +1 (908) 668-5000
 Fax: +1 (908) 668-5132

<http://www.anadigics.com>

Mktg@anadigics.com

IMPORTANT NOTICE

ANADIGICS, Inc. reserves the right to make changes to its products or to discontinue any product at any time without notice. The product specifications contained in Advanced Product Information sheets and Preliminary Data Sheets are subject to change prior to a product's formal introduction. Information in Data Sheets have been carefully checked and are assumed to be reliable; however, ANADIGICS assumes no responsibilities for inaccuracies. ANADIGICS strongly urges customers to verify that the information they are using is current before placing orders.

WARNING

ANADIGICS products are not intended for use in life support appliances, devices, or systems. Use of an ANADIGICS product in any such application without written consent is prohibited.