

General Description

The AWT6111 is a hetero-junction bipolar transistor (HBT) amplifier designed for the CDMA cellular handset. The frequency band of operation is 824-849 MHz. The AWT6111 is designed to operate from a single lithium-ion (Li-ion) battery. The amplifier input and output are matched to provide optimum

performance in a 50 Ω system. Minimal external components are required for proper RF bypassing. The tantalum capacitors, C8 and C9, are not required. Landings should be made available on the printed circuit board (PCB) as a precaution.

Table 1: AWT6111 Module Pin Description

PIN	NAME	DESCRIPTION	NOTES
1	V _{CC1}	Bias supply to 1st stage collector	3.0 - 4.2 V
2	RF _{IN}	RF Input	Use 50 Ω transmission line
3	V _{REF}	Reference supply to base bias	2.75 - 3.1 V
4	V _{MODE}	Mode select	0 V for high power mode, 2.7 V for low power mode
5	V _{CC2}	Bias supply to 2nd stage collector	3.0 - 4.2 V
6	RF _{OUT}	RF Output	Use 50 Ω transmission line
7	GND	Supply ground	DC ground

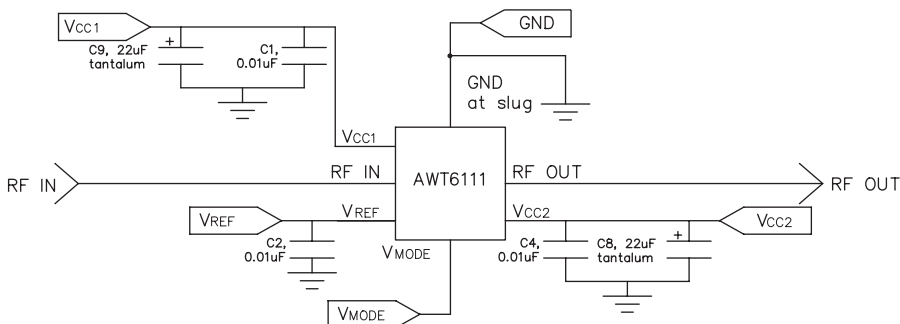
Figure 1: Application Schematic

Application Board

The application board was designed with GETEK material and 0.014" thickness.

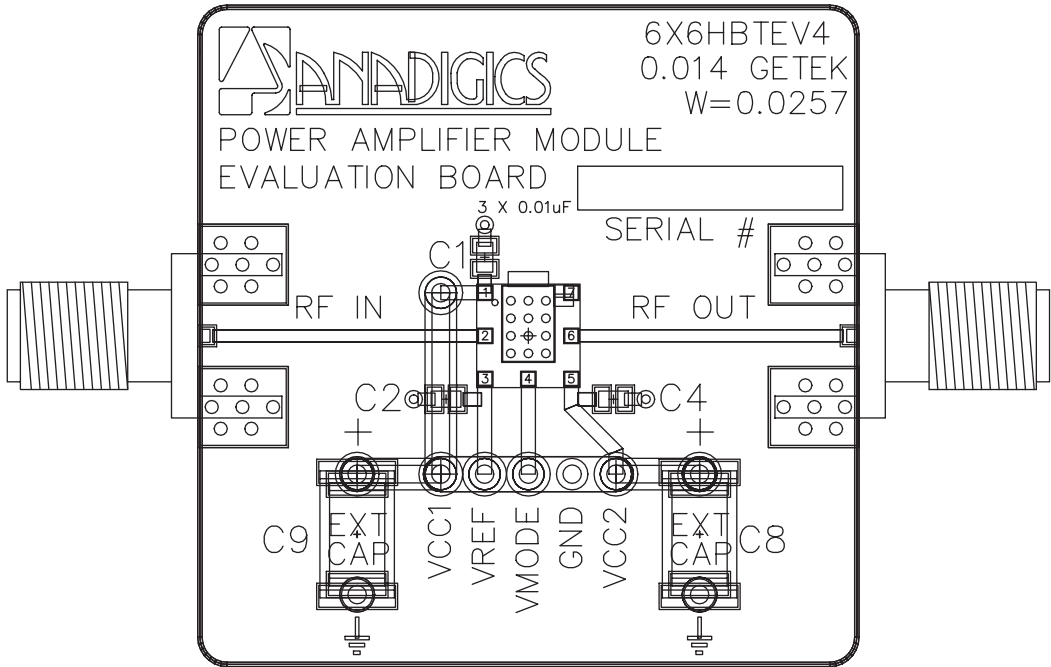

Figure 2: Evaluation Board Layout

Notes:

1. Copper trace width is 0.0257 ±0.001".
2. Relative dielectric constant is 4.37 at 1 GHz.
3. Dielectric thickness is 0.014 ±0.001".

Table 2: Parts List

DESCRIPTION	VALUE	FUNCTION
C1	0.01 uF	Bypass
C2	0.01 uF	Bypass
C4	0.01 uF	Bypass
C8	22 uF, tant.	Bypass
C9	22 uF, tant.	Bypass

C3, C5, C6 & C7 not used.

Designations same as engineering fixture.

Minimum Bench Requirements

The following minimum equipment is required for proper power amplifier operation.

1. Spectrum Analyzer
2. Three power supplies
3. CDMA function generator
4. RF filter (Surface Acoustic Wave-SAW)
5. Isolator
6. RF power meter
7. Coupler(s)

Turn On Procedures

Upon receiving the amplifier, the characterization sheet should be reviewed for the appropriate bias conditions. Review the evaluation board drawing prior to connection of the proper bias pins on the application board.

1. Be sure to connect the amplifier to 50 Ω RF in/out cables.
2. No RF power should be applied to the amplifier prior to biasing.
3. Attach V_{CC1} and V_{CC2} first; then V_{REF} and V_{MODE} .
4. Turn the V_{REF} supply to +2.85 V. Observe current draw of approximately 5 mA.
5. Turn on the V_{CC1} and V_{CC2} supply to +3.5 V. Observe current of ~100 mA from V_{CC} supply.
6. Turn on RF power applying +5 dBm. Gradually increase until the appropriate power level is obtained from the output (28.5 - 29 dBm in digital mode, 31 dBm in analog mode).
7. Perform measurements.

Layout Considerations

A sufficient number of holes (QTY 12 - 0.2mm diameter plated through hole) should be placed under the module in order to channel the heat properly. In addition, contact should be made between the PA slug located under the amplifier and the board. For hand assembly of the board, place sufficient bonding paste so that contact is made between the PA and ground. For large volume assembly, please refer to the solder profile recommendations application note. For RF in and out provide 50 Ω transmission lines.

Other Recommendations

In order to maximize performance in a CDMA system, the AWT6111 achieves full output power (+28.5dBm in digital mode and +31dBm in analog mode) while operating in low power mode. This minimizes quiescent current (47 mA typical) and eliminates the need for mode switching between high and low power or between analog and digital modes of operation. Applying logic low (0 V) to both V_{REF} and V_{MODE} pins, places the amplifier in shutdown (standby) mode. To minimize external switch requirements, the V_{REF} and V_{MODE} lines can be tied together. I_{MODE} is only ~300 uA, therefore tying it to the V_{REF} line doesn't significantly increase the current requirements on the switched line.

**ANADIGICS, Inc.**

141 Mount Bethel Road
Warren, New Jersey 07059, U.S.A.

Tel: +1 (908) 668-5000

Fax: +1 (908) 668-5132

URL: <http://www.anadigics.com>

E-mail: Mktg@anadigics.com

IMPORTANT NOTICE

ANADIGICS, Inc. reserves the right to make changes to its products or to discontinue any product at any time without notice. The product specifications contained in Advanced Product Information sheets and Preliminary Data Sheets are subject to change prior to a product's formal introduction. Information in Data Sheets have been carefully checked and are assumed to be reliable; however, ANADIGICS assumes no responsibilities for inaccuracies. ANADIGICS strongly urges customers to verify that the information they are using is current before placing orders.

WARNING

ANADIGICS products are not intended for use in life support appliances, devices or systems. Use of an ANADIGICS product in any such application without written consent is prohibited.