



Service Manual

Tumble dryer
Condensation electr.
AWZ 7813

Model Version		Page
	AWZ 7813	
	8575 781 03030	
	Technical data	2 - 3
	Spare part list	4
	Exploded view	5 - 6
	Wiring diagram	7
	Circuit diagram	8
	Text/Legend	9 - 14
	Family	ALPHA



Technical data**Dimensions**

Height	85	cm
Width	59.5	cm
Depth	60	cm

Weight

Gross weight	40	kg
Net weight	38	kg

Surroundings temperature

Max. room temperature	35	°C
Min. room temperature	5	°C

Humidity

Max. relative humidity	95	%
------------------------	----	---

Power connection

Voltage	230	V
Frequency	50	Hz
Connected load	2.19	kW
Fuse	10	A

Drum data

Volume	112	l
Drum speed	57 ± 2	rpm

Airflow

Circulation air flow	200 +10/ -30	m ³ /h
Cooling air flow	180 +10/ -30	m ³ /h

Capacity of laundry

Cotton max.	6	kg
Easy care max.	2.5	kg

Condenswater evacuation

Condenswater container	3	l
------------------------	---	---

Electrical components**Heating**

Type	IRCA 1T.8294004	
Nominal voltage	230 +10%/ -15% V	
Nominal power	1900	W ± 5%
Heating resistances:	25.2-28.4 Ω	

Thermostats**Fluff thermostat (in heater) TH 1.2**

Switch on temperature	165 ± 10	°C
Switch off temperature	210 ± 9	°C
Color code	Green	

Safety thermostat (in heater) TL

Switch on temperature	<-35	°C
Switch off temperature	260 ± 10	°C

Exhausting thermostat (in airchannel) TH 1.1

Switch on temperature	68 ± 3	°C
Switch off temperature	83 ± 3	°C

Control module Alphatronic

Type	INVENSYS	
Nominal voltage	230 +10%, -15% V	
Frequency	50/60	Hz

Rated currents

Motor	≤10	A
Heater	≤16	A

Temperature

Ambient	up to 85 °C	
Storage	-25 to 85 °C	

Main- and blower motor

Type	1-phase asynchronous	
Nominal voltage	230 +10%/ -15% V	
Frequency	50 ± 3	Hz
Power consumption	285	W ± 7%
Resistances of coils:		
Main coil (2 - 3)	18.8	Ω ± 7%
Auxiliary coil (3 - 4)	18	Ω ± 7%
Rated speed	2700	rpm
Capacitor	10	μ F ± 10%

Radio interference filter

Typ	ISKRA KPB 7325	
Voltage max.	275	V
Capacity	0.25 μ F X1 + 2 x 0.022 μ F Y2 + 1MΩ	

Radio interference filter

Typ	Eichhoff BV 16.250/119	
Voltage max.	250	V
Capacity	100 μ F X1 + 2x15 μ F Y2 + 1MΩ	

Technical data**Micro switch SLE**

Type	Cherry D45	
Kind of switch	Single pole	
Contact	Change over contact/spring contact	
Voltage	230 +10%/-15%	V
Frequency	50/60	Hz
Current	15	A

Display

No. of LEDs	18
-------------	----

Options buttons

Start	SST
Gentle	SG
Buzzer	SBU

Program selector	12 positions integrated ON/OFF (stand-by)
------------------	---

Efficiency class

Energy class	C
--------------	---

Spare part list

Model AWZ 7813
Service No. 857578103030
Version 857578103030

Pos. No.	12NC Code	Description
004 0	4812 440 19718	Bottom
011 0	4812 500 18054	Foot adjustable
012 0	4812 528 78033	Roll
012 1	4812 528 98003	Shaft Front + Roll
012 2	4812 520 28068	Shaft rear
021 0	4812 440 10819	Front VBL GW
022 0	4812 440 10821	Panel,side GW
024 0	4812 440 19708	Panel, rear
030 0	4812 440 11169	Table top CD EBL WH
033 0	4812 310 18582	Kit Push in cover
053 0	4812 440 11155	Flap EBL WH
053 2	4812 417 28103	Lock transmit. plith EBL
053 4	4812 440 89104	Plinth f. tank bottom EBL WH
053 5	4812 417 28102	Axle f.flap EBL
065 1	4812 325 18009	Insulation rear panel
100 0	4812 440 11154	Door CD WH EBL
131 1	4812 271 38463	Door lock system GW
133 0	4812 452 14629	Handle,door + hook WH EBL
133 2	4812 417 28056	Lock Bag filter
191 0	4812 466 68607	Gasket, door
220 0	4812 418 18177	Drum cpl. SS
223 0	4812 418 89017	Drum lifter GW
271 0	4812 358 18164	Belt,driving 1936 H7 CD RO
273 0	4812 358 18055	Pulley jockey
275 0	4812 492 68129	Spring
291 0	4812 466 68561	Gasket front
291 2	4812 466 68562	Gasket Drum rear
301 0	4812 452 14619	Control panel
331 0	4812 412 59071	Knob,timer EBL
332 0	4812 513 18151	Button Start EBL
332 1	4812 513 18152	Push button Opt. EBL
401 0	4812 361 18291	Motor incl. fan wheel
401 1	4812 401 18421	Clamp Motor
401 2	4812 401 18229	Clamp motor support
420 0	4812 121 18144	Capacitor 10 µ F
421 0	4812 121 18158	Interf.filter
443 0	4812 361 18292	Blower wheel
443 1	4812 361 18293	Fan wheel blower
443 2	4812 290 88066	Clamp blower wheel
456 0	4812 310 18585	Heating element Kit 1900W
490 0	4812 321 18042	Connect.cable 3m
490 0	4812 321 18044	Cable,mains 5m 4x1
490 1	4812 321 28367	Strain relief
492 1	4812 401 18195	Clip
521 0	4812 214 79333	Control board ALPHA ED
557 0	4812 282 08008	Thermostat drum outlet
557 1	4812 282 98005	Gasket Thermostat
564 0	4812 259 28681	Thermostat Kit
631 0	4812 271 38396	Microswitch f. pump/belt
631 3	4812 271 18084	Floater system cpl. 6kg
633 1	4812 276 18422	Pin Start reset GW
653 3	4812 134 48324	Light guide ALPHA WH
692 0	4812 210 58035	Bracket Sensor GW
692 1	4812 278 58001	Sensor
740 0	4812 511 48226	Heat exchanger H3

Pos. No.	12NC Code	Description
741 0	4812 440 08003	Blower cold air
741 1	4812 530 48244	Cover blower house
743 0	4812 530 48629	Air guide without hole GW
743 1	4812 530 48253	Heating chamber aluzinc
743 3	4812 530 48239	Cover blow. house
743 4	4812 464 48122	Cover plate
743 8	4812 466 88519	Gasket f. blow. house
750 0	4812 418 18521	Tank bottom white 6kg
761 0	4812 480 58322	Filter bag GW
794 0	4812 466 88523	Gasket AC,Bottom
794 1	4812 466 28108	Gasket heater channel
794 2	4812 466 98935	Sealing Heater holder
794 3	4812 466 98937	Sealing
794 4	4812 466 88521	Gasket filter
900 1	4812 290 88053	Clip
902 2	4812 256 38004	Holder heater
903 0	4812 532 28028	Clip,fix
903 1	4812 401 18228	Fastener
910 1	4812 502 48347	Screw,selftap 3,5x14SS
910 5	4819 502 38265	Screw VAB 4,5x20
910 8	4812 502 48348	Screw ST 4,2x11
912 4	4812 502 48015	Screw 4,0x16-TORX
922 0	4812 532 58005	Ring,circlip Triring
922 1	4812 532 58007	Ring,circlip
930 0	4812 492 98039	Spring f.flap
950 0	4812 466 48101	Felt,strip bottom group
950 1	4812 466 88517	Gasket inlet bottom
952 3	4812 466 88522	Gasket sensor wiring
962 0	4812 466 38012	Protector Motor
962 2	4812 466 38056	Protec,el.parts Foil Aluminium

Exploded view

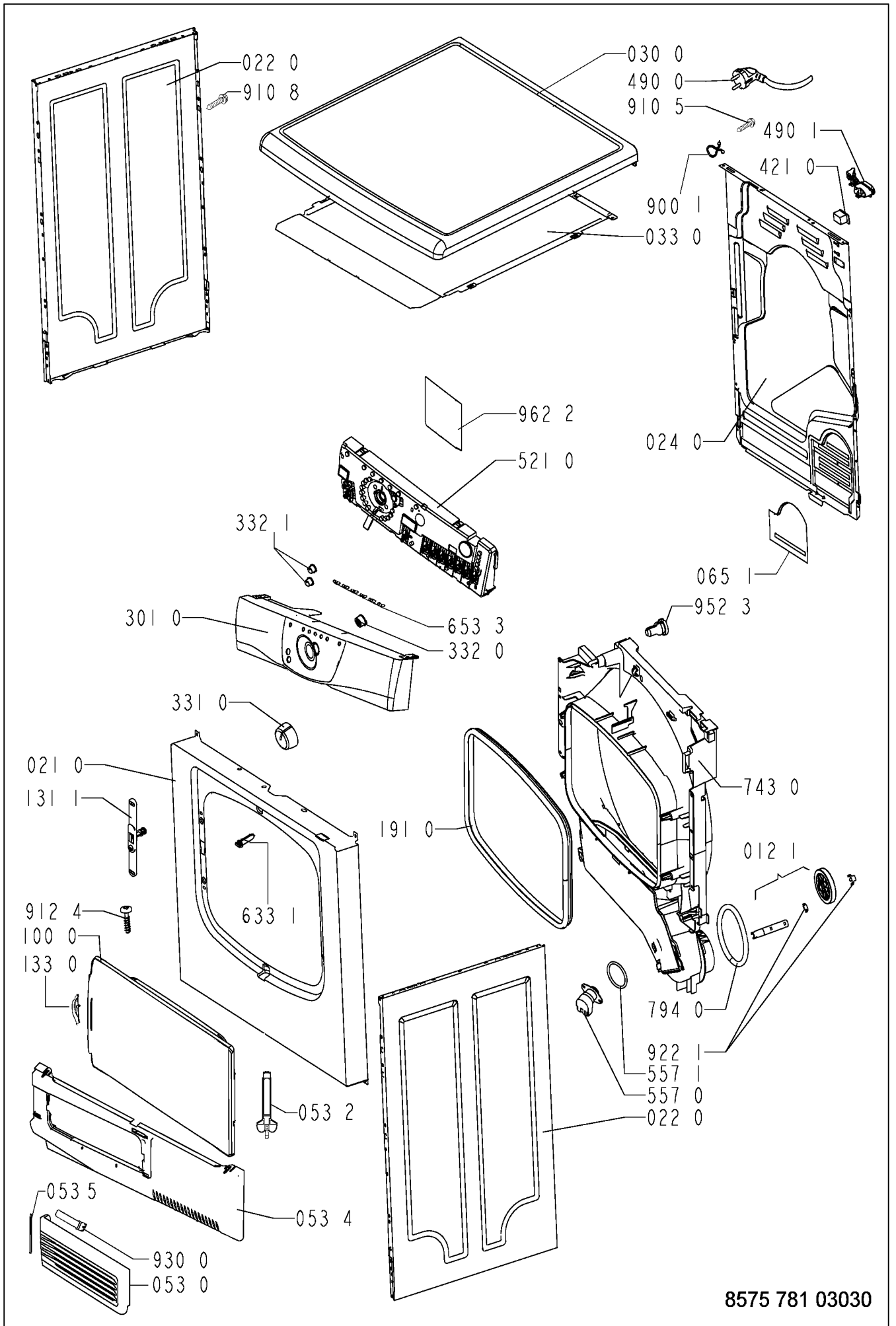

Exploded view

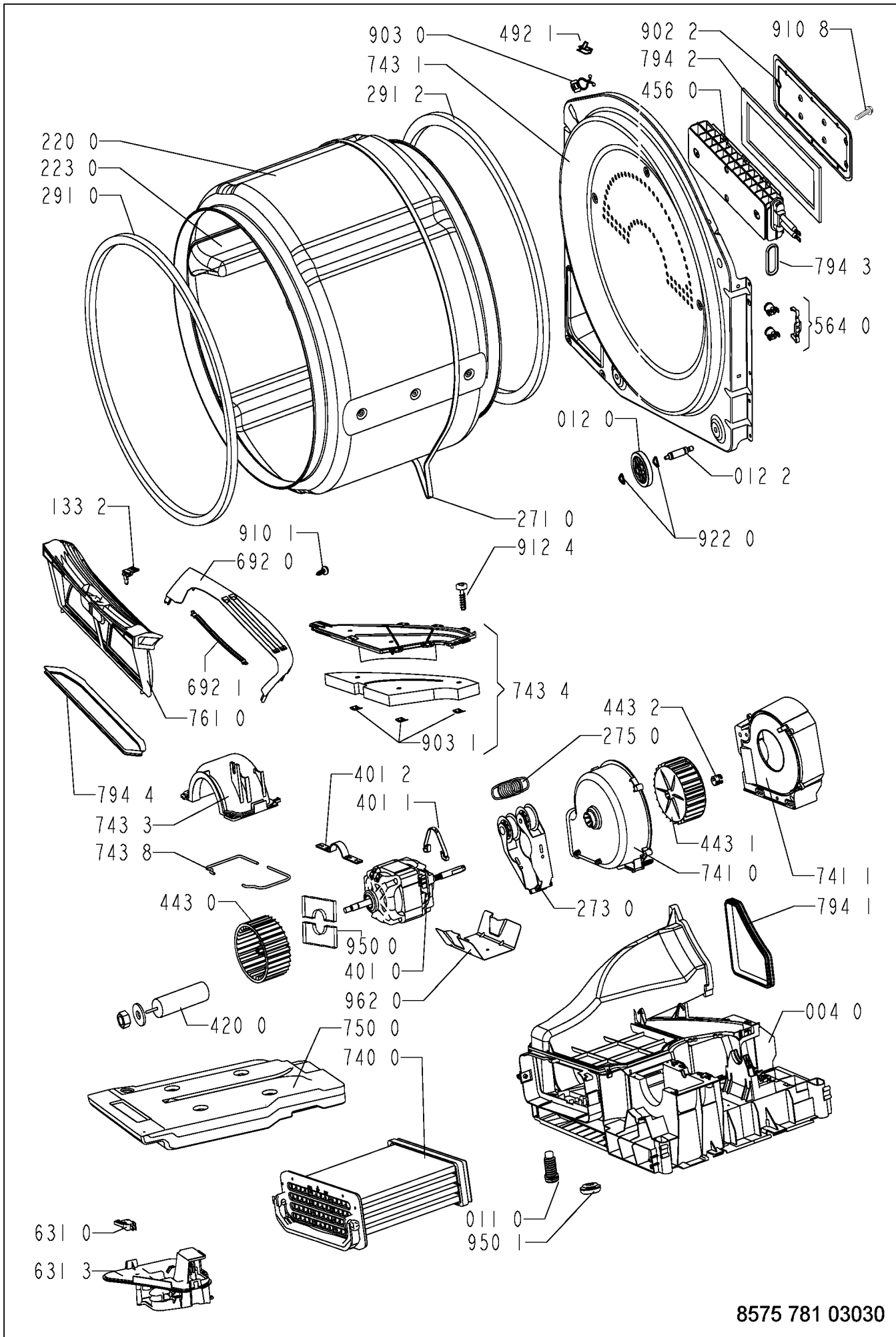

Wiring diagram

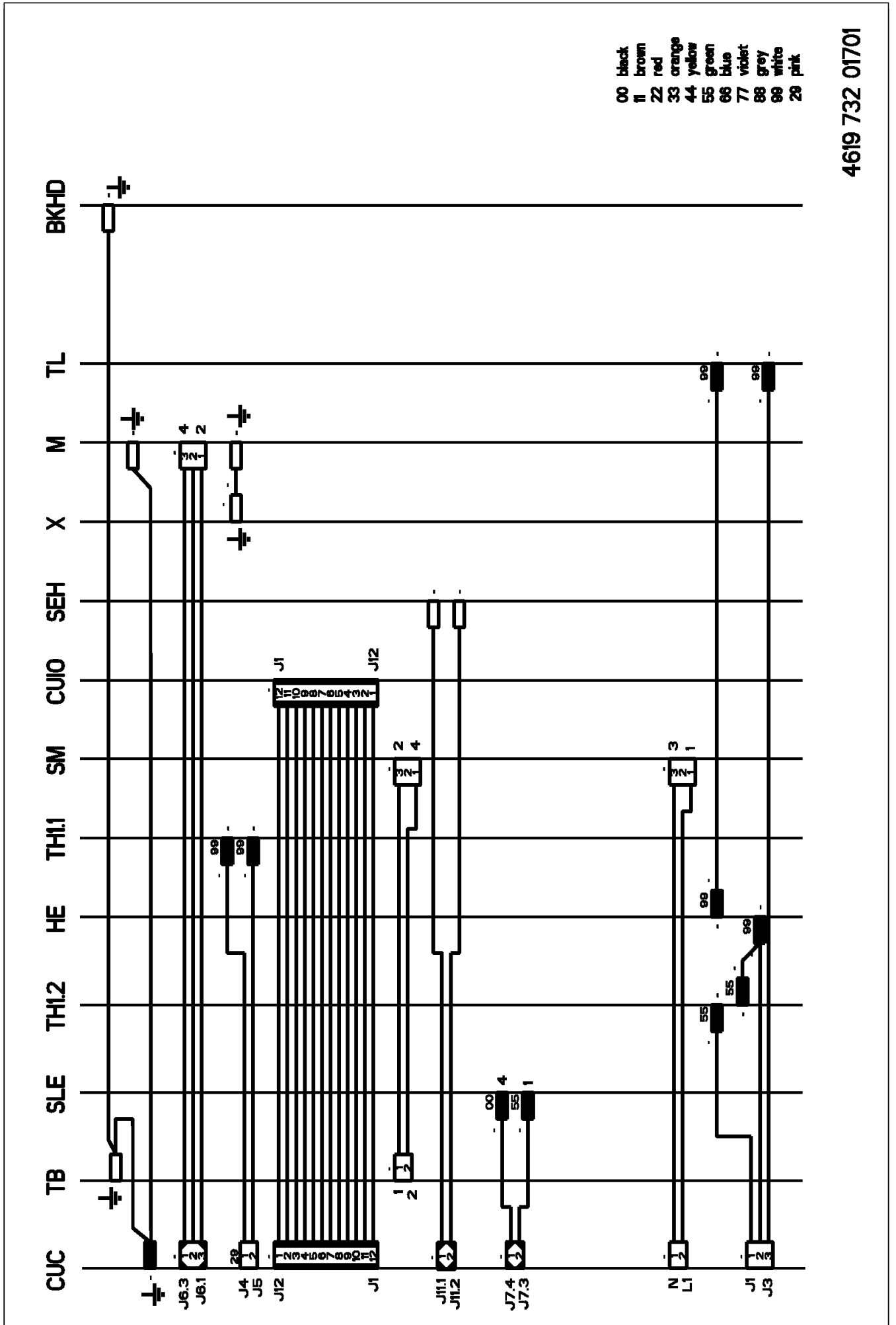

Circuit diagram

4619 732 01701

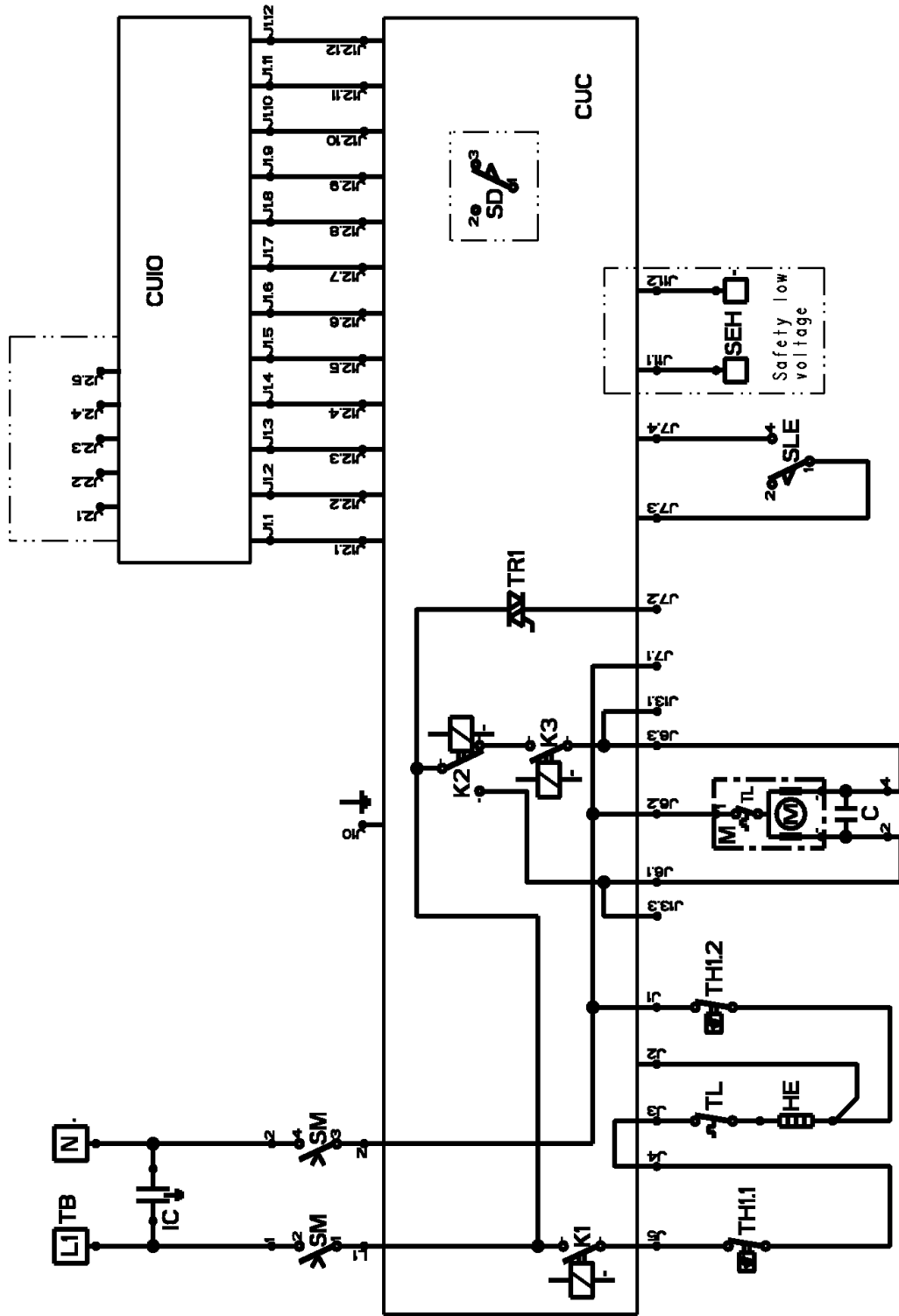

1 2 3 4 5 6 7 8 9 10 11 12 13 14 15 16 17 18 19 20 21 22 23 24 25 26 27 28 29 30 31 32 33 34 35 36 37 38

- BK-ID bulkhead
- C capacitor
- CUC control unit, central
- CUJO control unit, display
- HE heating element
- IC interference capacitor
- M motor, drive
- SD switch, door
- SEH sensor, humidity
- SLE switch, level
- SM switch, mains
- TB terminal block
- TH1 thermostat fix (drum outlet)
- TH2 thermostat fix (fluff filter)
- TL temp. limiter

Text/Legend

Program Flow for WH AV (Airvented)

Program Phase	Options influencing program phase	Motor movement	Heating Cycles				Humidity measurement	Duration	Conditions to go in the next phase
			Cotton	Easy Care	Time Drying (Jet)	Airing			
Programming (Selection)	-	off	off	off	off	off	off	-	push start button AND door closed
Drying I	Gentle	rev	100%	100%	75%		on	RH=HT1 or t ₁	WH AV HT 1 OR duration
	Normal	rev	100%	100%	100%	↓	on	RH=HT1 or t ₁	
Drying II	Gentle	rev	90%	90%	↓	-	on	RH=HT2 or timeout	WH AV HT 2 OR timeout
	Normal	rev	100%	100%	90%	↓	on	RH=HT2 or timeout	
Drying III	Gentle	rev	75%	75%	↓	-	on	RH=HT3 or timeout	WH AV HT 3 OR timeout
	Normal	rev	90%	90%	↓	↓	on	RH=HT3 or timeout	
Drying IV	Gentle	rev	75%	75%	↓	-	on	RH=target or timeout	selected humidity OR timeout
	Normal	rev	75%	75%	↓	↓	on	RH=target or timeout	
Cool Down	-	rev	off	off	off	off	off	t _{cd}	duration
Antcrease	-	rev-ac	off	off	off	off	off	t _{ac}	duration
Drying End	-	off	off	off	off	off	off		

Humidity Targets	
HT1	RH=22 %
HT2	RH=22 %
HT3	RH=15 %
selected humidity	RH= selected program target

Reversing type	off (sec)	cw (sec)	off (sec)	ccw (sec)
rev	2	80	2	6
rev-ac	2	80	2	6

Duration	
t ₁	60 min Cotton / 20 min Easy Care
timeout	60 min
t _{cd}	6 min
t _{ac}	60 min

Heater cycles	Heater on	Heater off
100%	180 sec	0 sec
90%	162 sec	18 sec
75%	136 sec	44 sec

Text/Legend

Program flow WH CD WCT and WH CD WCB (Condenser)

Program Phase	Options influencing program phase	Motor movement	Heating Cycles				Humidity measurement	Duration	Conditions to go in the next phase
			Cotton	Easy Care	Time Drying (Jet)	Airing			
Programming (Selection)	-	off	off	off	off	off	off	-	push start button AND door closed
Drying I	Gentle	rev	100%	100%	78%		on	RH=HT1 or t ₁	WH CD HT 1 OR duration
	Normal	rev	100%	100%	100%	⇓	on	RH=HT1 or t ₁	
Drying II	Gentle	rev	90%	90%	⇓	-	on	RH=HT2 or timeout	WH CD HT 2 OR timeout
	Normal	rev	100%	100%	90%	⇓	on	RH=HT2 or timeout	
Drying III	Gentle	rev	78%	78%	⇓	-	on	RH=HT3 or timeout	WH CD HT 3 OR timeout
	Normal	rev	90%	83%	⇓	⇓	on	RH=HT3 or timeout	
Drying IV	Gentle	rev	67%	67%	⇓	-	on	RH=target or timeout	selected humidity OR timeout
	Normal	rev	78%	67%	⇓	⇓	on	RH=target or timeout	
Cool Down	-	rev	off	off	off	off	off	t _{cd}	duration
Anticrease	-	rev-ac	off	off	off	off	off	t _{ac}	duration
Drying End	-	off	off	off	off	off	off		

WH = Whirlpool, CD = Condense Dryer, WCT = Water Container Top, WCB = Water Container Bottom

Humidity Targets	
HT1	RH=22 %
HT2	RH=22 %
HT3	RH=15 %
selected humidity	RH= selected program target

Reversing type	off (sec)	cw (sec)	off (sec)	ccw (sec)
rev	2	80	2	6
rev-ac	2	80	2	6

Duration	
t ₁	60 min Cotton / 20 min Easy Care
timeout	60 min
t _{cd}	12 min, 9min for 20min jet program
t _{ac}	60 min

Heater cycles	Heater on	Heater off
100%	180 sec	0 sec
90%	162 sec	18 sec
83%	150 sec	30 sec
78%	140 sec	40 sec
67%	121 sec	59 sec

Text/Legend

Testpoints at power board

Alphatronic WH

WH AV (AIR VENTED), WH CD WCT and WH CD WCB (CONDENSER)

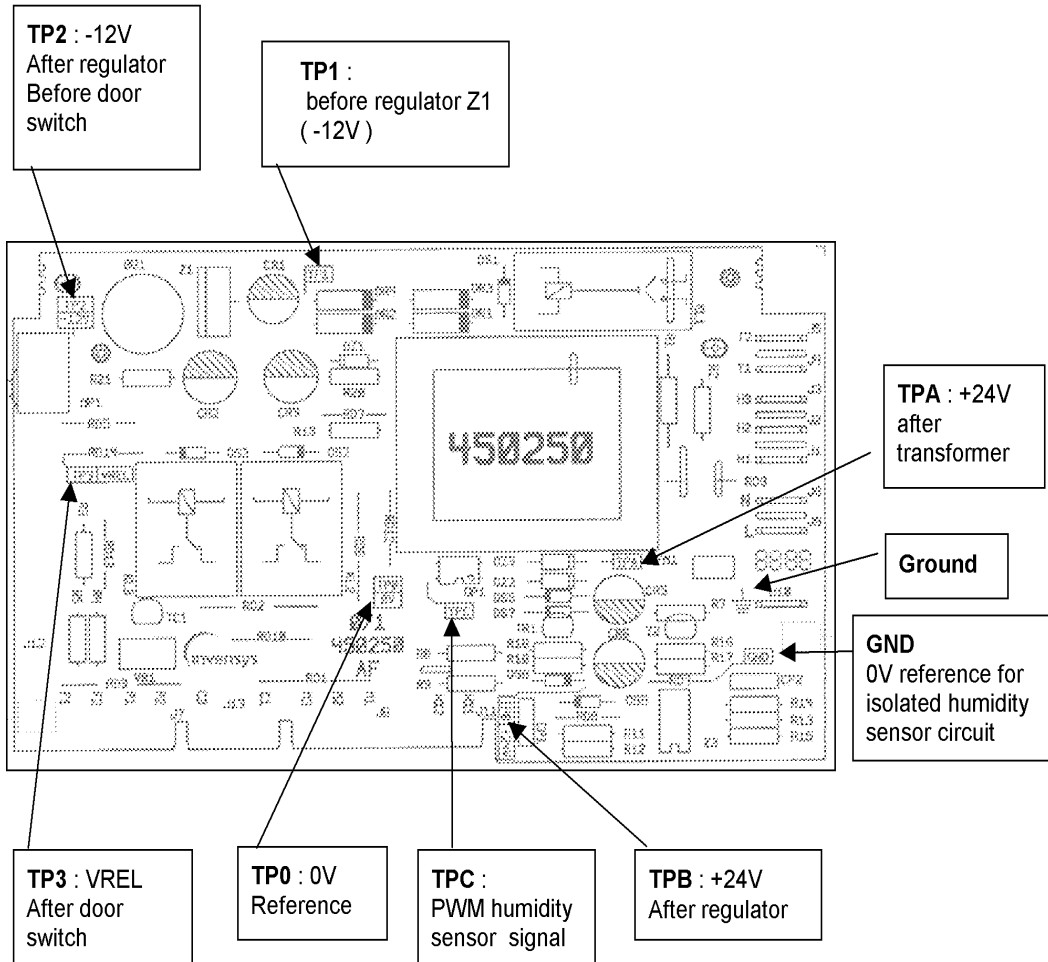

TP0: reference for -12V circuit (RD6)
 TP1: -12V after transformer, unregulated (DR4)
 TP2: -12V regulated (MP1)
 TP3: -12V regulated if door closed (RD14)
 -1,1V if door opened

GND: reference for class II isolated humidity sensor circuit (RD4)
 TPA: +24V after transformer, unregulated (DZ3)
 TPB: +24V regulated (DS8)
 TPC: PWM signal of humidity sensor (OP1)

WH = Whirlpool, CD = Condense Dryer, AV = Airvented,
 WCT = Water Container Top, WCB = Water Container Bottom

Text/Legend

Test programs

The TEST MODE delivers the possibility to check several functions of the dryer independently of the normal drying programs.

Entering the Test Mode

- a) Close door of the dryer or block door switch
- b) Rotate program selector to position „Airing“
- c) Press and release option button „Gentle“ three times within 6 sec. (If accidentally the button is pushed more than three times, this will have no negative impact. The test mode will start in step1 anyway)

If the sequence a) - c) is correct: =>Test Mode basic signal is displayed (see Test mode display)and Step1 of test program is executed.

Advance to next step

Push OPT2: "Buzzer"

Leaving the Test Mode

The TEST MODE is terminated by:

- Push Start Button
 OR
- Interrupt of the mains supply for a time of 40 sec.

OR
- Open door
 OR
- Turn rotary selector
 OR
- Last step of test program is reached and button OPT2 is pushed once more

Test mode display

When test mode is entered:

LED group:	Behaviour:
Program sequence LEDs (PS2...PS5)	Indication of test step acc. table „indication“
Buzzer	Beeps when button OPT1 („Gentle“) is pushed

Text/Legend

Indication

Indicator	Test Program Step								
	Step1>>	Step2>>	Step3>>	Step4>>	Step5>>	Step6>>	Step7>>	Step8>>	Step9
LED PS2 (Overdry Protection)	ON	OFF	OFF	OFF	ON	ON	ON	ON	ON
LED PS3 (Drying)	ON	ON	OFF	OFF	ON	OFF	OFF	ON	ON
LED PS4 (End)	ON	OFF	ON	OFF	OFF	ON	OFF	ON	OFF
LED PS5 (Anticrease)	ON	OFF	OFF	ON	OFF	OFF	ON	OFF	ON

After sales service test program

The test program works sequentially, that means the change from one program step to the next has to be done only by request of pushing the OPT2 button!

Test Program Step No.	Test/Tested Component	Description	
			Test Mode is entered
Step 1**	Factory Test Program 1	Motor: ON, short reversing rev-x Heating Element: ON, cycle heat-x Display and Button Test: ON Humidity Input Test/float: ON	Push OPT2 button
Step 2**	Factory Test Program 2	Motor: ON, long reversing rev-y Heating Element: ON, cycle heat-y Display and Button Test**: ON Humidity Input Test/float**: ON	Push OPT2 button
Step 3	Pump & Float Switch	WH CD WCT: 1) Fill in water until float switch is switched. 2) Container LED is switched ON and pump is switched ON WH CD WCB: 1) Pull out container (switch switches) 2) Container LED is switched ON WH AV: skip this test step manually!	Push OPT2 button
Step 4	Motor CCW	Motor: ON, ccw Heating Element: OFF	Push OPT2 button
Step 5	Motor CW	Motor: ON, cw Heating Element: OFF	Push OPT2 button
Step 6	Heating Element Full Power	Heating Element: ON, 100% Motor: ON, cw	Push OPT2 button
Step 7	Heating Element Reduced Power	Heating Element: ON, 78% Motor: ON, cw	Push OPT2 button
Step 8**	Humidity Input	Description see below	Push OPT2 button
Step 9	Display last failure/error code	Last error/failure code is displayed	Push OPT2 button
EXIT	Leave Test Mode	Go to Programming phase (Selection)	

**Description see below

Text/Legend

Heating and Reversing Cycle for Factory Test Program 1 (Step1) :

Dryer Type	Heating Element heat-x		Motor rev-x			
	Heater ON	Heater OFF	CW ON	OFF	CCW ON	OFF
Condenser	12 sec	0 sec	4 sec	2 sec	4 sec	2 sec
Airvented	11 sec	0 sec	3 sec	2 sec	4 sec	2 sec

Heating and Reversing Cycle for Factory Test Program 2 (Step2):

Dryer Type	Heating Element heat-y		Motor rev-y			
	Heater ON	Heater OFF	CW ON	OFF	CCW ON	OFF
Condenser	26 sec	0 sec	10 sec	3 sec	10 sec	3 sec
Airvented	21 sec	0 sec	10 sec	3 sec	5 sec	3 sec

Humidity Measurement Test

Max. Duration: no limit

- Description:
- Test is active during Steps 1+2 and Step8
 - Resistors have to be connected at the humidity sensor
 - Door must be closed or door switch blocked (otherwise 24V power supply off)
 - LEDs indicates measured humidity level due to following table:

Resistances	LED OPT1 ("Gentle")	LED Failure 2 ("Fluff Filter")
250 kOhm	ON	OFF
1130 kOhm	ON	ON
3700 kOhm	OFF	ON
open circuit	OFF	OFF

Display and Button test

- Description:
- Test is active during all test steps.
 - If option buttons are pushed LEDs are switched on and off. (exception: OPT1 button 'Gentle', this button is used for humidity measurement)