



APEX DISPLAY LIMITED

TEL : 82-2-2612-4767 FAX : 82-2-6679-4767

ADD:NA-3323, Jung-Ang Complex, 1258, Gurobon-Dong, Guro-Gu,
Seoul, 152-721, South Korea

SPECIFICATION FOR LCM MODULE

MODULE NO.:AX07023

DOC.REVISION: A01

SAMPLE REVISION: A

Customer Approval:

--

	SIGNATURE
PREPARED BY (LCM ENGINEER)	
CHECKED BY (QA ENGINEER)	
CHECKED BY	
VERIFIED BY	
APPROVED BY	

1. GENERAL SPECIFICATIONS	1
2. ABSOLUTE MAXIMUM RATINGS	1
3. ELECTRICAL CHARACTERISTICS	3
4. OPERATING PRINCIPLES & METHODS	5
5. DISPLAY DATA RAM ADDRESS MAP	8
6. ELECTRO-OPTICAL CHARACTERISTICS	9
7. BLOCK DIAGRAM	10
8. POWER SUPPLY	10
9. PIN CONNECTIONS	11
10. BACK LIGHT SPECIFICATION	11
11. PART LIST	12
12. PCB CIRCUIT AND LAYOUT	13
13. QUALITY ASSURANCE	17
14. PRECAUTIONS IN USING LCM	21
15. DIMENSIONAL OUTLINE	22
16. PACKAGING INFORMATION	23
17. USING LCD MODULES	24

1. GENERAL SPECIFICATIONS

Item	Contents	Unit
LCD type	STN/Y-G/Positive/Transflective	---
LCD duty	1/64	---
LCD bias	1/9	---
Viewing direction	6:00	O'clock
Module size (W×H×T)	93.0 × 70.0 × 12.5mm MAX	mm
Viewing area (W×H)	72.5× 39.5	mm
Number of dots	128 × 64	dots
Dot size (W×H)	0.48 × 0.48	mm
Dot pitch (W×H)	0.52 × 0.52	mm
Backlight type/Color	LED side backlight / Yellow-Green	---

2. ABSOLUTE MAXIMUM RATINGS

2.1 Electrical Absolute Maximum Ratings

V_{SS}= 0V, Ta = 25°C

Parameter	Symbol	Min	Max	Unit
Supply voltage for logic	VDD-VSS	-0.3	7.0	V
Supply voltage for LCD	VDD-VO	0	16.5	V
Input voltage	VI	VSS-0.3	VDD+0.3	V
Operating temperature	TOP	-20	70	°C
Storage temperature	TST	-30	80	°C

2.2 Electronic Static Discharge maximum rating

ESD test method : IEC1000-4-2

Item	Description	
Testing environment	Ambient temperature :15°C to 35 °C Humidity: 30% to 60 % LCM (E.U.T) : Power up	
Testing equipment	Manufacture: NoiseKen, Model No. ESD-100L	
Testing condition	See drawing 1	
Direct discharge	0 to ± 4 KV	Discharge point, see drawing 2
Indirect discharge	0 to ± 8 KV	Discharge point, see drawing 1
Pass condition	No malfunction of unit. Temporary malfunction of unit which can be recovered by system reset	
Fail condition	Non. Recoverable malfunction of LCM or system	

FIG 1 ESD TESTING EQUIPMENT

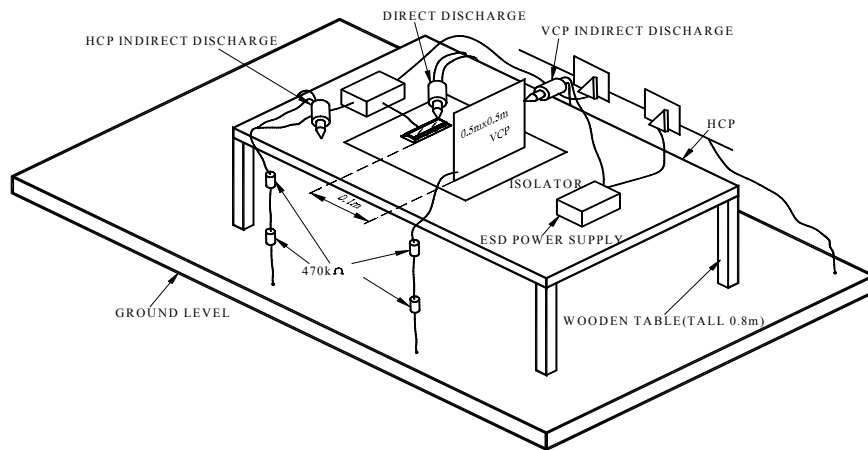

(1)

DIRECT CONTACT DISCHARGE CONTACT POINT : A.B.C.D

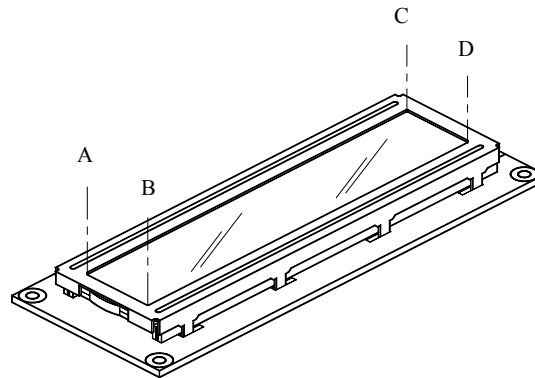

(2)

3. ELECTRICAL CHARACTERISTICS (VDD = +5V±5%, VSS = 0V, Ta = 25°C)

3.1 DC Characteristics

Parameter	Symbol	Condition	Min	Typ	Max	Unit
Supply voltage for logic	VDD-VSS	---	4.5	5.0	5.5	V
Supply current for logic	IDD	VDD-VSS=5V	---	3.8	6.0	mA
Operating voltage for LCD	VDD - VO	25°C	8.6	9.3	9.7	V
Input voltage 'H' level	VIH	---	0.7VDD	---	VDD	V
Input voltage 'L' level	VIL	---	VSS	---	0.3VDD	V

3.2 AC Characteristics

MPU Interface

Characteristic	Symbol	Min	Typ	Max	Unit
E cycle	tcyc	1000	---	---	ns
E high level width	twhE	450	---	---	ns
E low level width	twlE	450	---	---	ns
E rise time	tr	---	---	25	ns
E fall time	tf	---	---	25	ns
Address set-up time	tas	140	---	---	ns
Address hold time	tah	10	---	---	ns
Data set-up time	tdsw	200	---	---	ns
Data delay time	tddr	---	---	320	ns
Data hold time(write)	tdhw	10	---	---	ns
Data hold time(read)	tdhr	20	---	---	ns

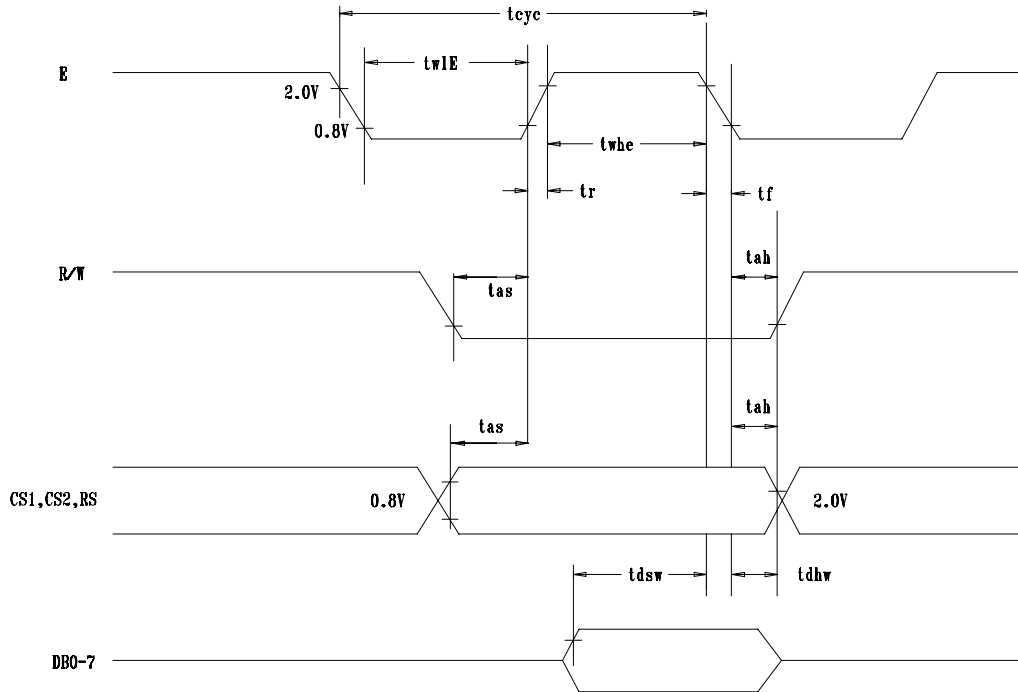

MPU Write Timing

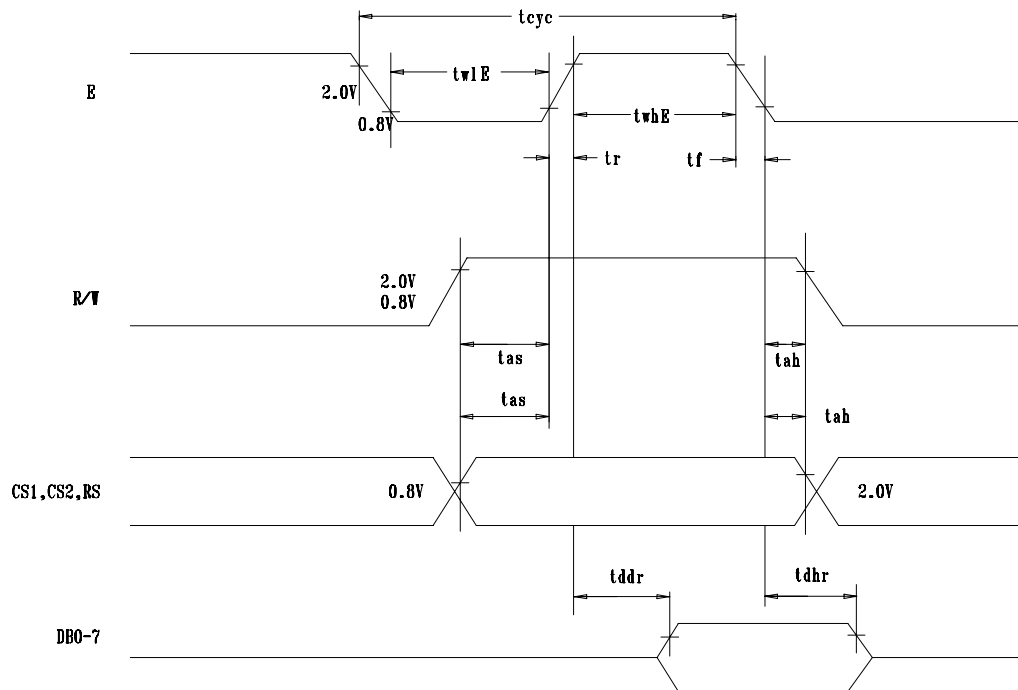

MPU Read Timing

4. OPERATING PRINCIPLES & METHODS

4.1 I/O Buffer

Input buffer controls the status between the enable and disable of chip. Unless the CS1 or CS2 is in active mode, input or output of data and instruction do not execute. Therefore internal state is not changed. But RSTB can operate regardless of CS1 and CS2.

4.2 Input Register

Input register is provided to interface with MPU which is different operating frequency. Input register stores the data temporarily before writing it into display data RAM.

When CS1 or CS2 is in the active mode, R/W and RS select the input register. The data from MPU is written into input register and then write it into display data RAM. Data is latched when falling of the E signal and written automatically into the display data RAM by internal operation.

4.3 Output Register

Output register stores the data temporarily from display data RAM when CS1 or CS2 is in active mode and R/W and RS=H. Stored data in display data RAM is latched in output register. When CS1 or CS2 is in active mode and R/W=H, RS=L, status data (busy check) can be read out.

To read the contents of display data RAM, twice access of read instruction is needed. In first access, data in display data RAM is latched into output register. In second access, MPU can read data which is latched. That is, to read the data in display data RAM, it needs dummy read.

But status read does not need dummy read.

RS	R/W	Function
0	0	Instruction
	1	Status read(busy check)
1	0	Data write(from input register to display data RAM)
	1	Data read(from display data RAM to output register)

4.4 Reset

System reset can be initialized by setting RSTB terminal at low level when turning power on, receiving instruction from MPU. When RSTB becomes low, following procedure is occurred.

- Display off
- Display start line register become set by 0.(Z-address 0)

While RSTB is low level, no instruction except status read can be accepted. Reset status appears at DB4. After DB4 is low, any instruction can be accepted.

The Conditions of power supply at initial power up are shown in table 1.

Table1. Power Supply Initial Conditions

Item	Symbol	Min	Typ	Max	Unit
Reset time	t_{RST}	1.0	---	---	us
Rise time	t_r	---	---	200	ns

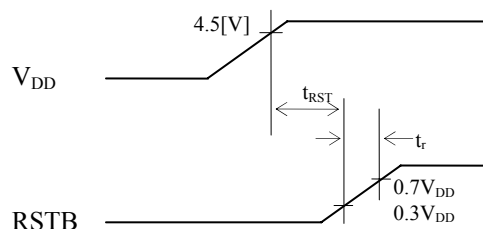

4.5 Busy Flag

Busy flag indicates that KS0108B is operating or not operating. When busy flag is high, KS0108B is in internal operating. When busy flag is low, KS0108B can accept the data or instruction.

DB7 indicates busy flag of the KS0108B.

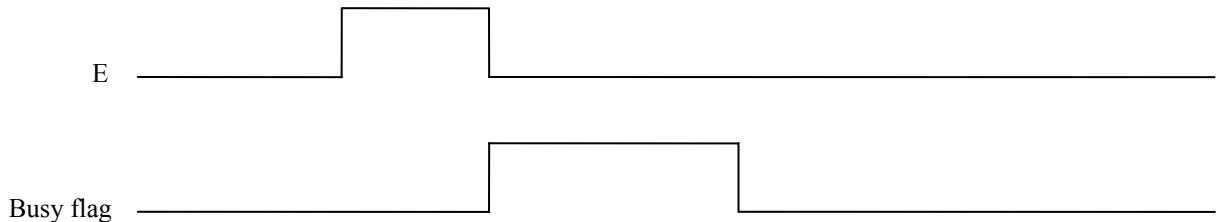

4.6 Display ON/OFF Flip-Flop

The display on/off flip-flop makes on/off of the liquid crystal display. When flip-flop is reset (logical low), selective voltage or non selective voltage appears on segment output terminals. When flip-flop is set (logical high), non selective voltage appears on segment output terminals regardless of display RAM data.

The display on/off flip-flop can change status by instruction. The display data at all segments disappear while RSTB is low. The status of the flip-flop is output to DB5 by read instruction.

4.7 X page Register

X page register designates page of the internal display data RAM. It has not count function. An address is set by instruction.

4.8 Y Address Counter

Y address counter designates address of the internal display data RAM. An address is set by instruction and is increased by 1 automatically by read or write operations of display data.

4.9 Display Data RAM

Display data RAM stores a display data for liquid crystal display. To express on state of dot matrix of liquid crystal display. Write data 1. The other way. Off state writes 0.

4.10 Display Start Line Register

The display start line register indicates address of display data RAM to display top line of liquid crystal display. Bit data (DB0 to DB5) of the display start line set instruction is latched in display start line register. The latched data is then transferred to the X-Address counter when FRM is "HIGH", thereby presetting the Z-Address counter.

4.11 Display Control Instruction

The display control instructions control the internal state of the KS0108B. Instruction is received from MPU to KS0108B for the display control. The following table shows various instructions.

Instruction	RS	R/W	DB7	DB6	DB5	DB4	DB3	DB2	DB1	DB0	Function	
Display ON/OFF	0	0	0	0	1	1	1	1	1	0/1	Controls the display on or off. Internal status and display RAM data are not affected. 0:OFF, 1:ON	
Set Address	0	0	0	1	Y address (0~63)						Sets the Y address in the Y address counter.	
Set Page (X address)	0	0	1	0	1	1	1	Page (0~7)			Sets the X address at the X address register.	
Display Start Line	0	0	1	1	Display start line (0~63)						Indicates the display data RAM displayed at the top of the screen.	
Status Read	0	1	B U S Y	0	O N / O F F	R E S E T	0	0	0	0	Read status. BUSY 0 : Ready 1 : In operation ON/OFF 0 : Display ON 1 : Display OFF RESET 0 : Normal 1 : Reset	
Write Display Data	1	0	Write Data									Writes data (DB0:7) into display data RAM. After writing instruction, Y address is increased by 1 automatically.
Read Display Data	1	1	Read Data									Reads data (DB0:7) from display data RAM to the data bus.

6. ELECTRO-OPTICAL CHARACTERISTICS (V_{OP} = 9.3V Ta = 25°C)

Item	Symbol	Condition	Min	Typ	Max	Unit	Remarks	Note
Response time	Tr	---	---	332	---	ms	---	1
	Tf	---	---	146	---	ms	---	1
Contrast ratio	Cr	---	---	7.8	---	---	---	2
Viewing angle range	θ	Cr ≥ 2	27	---	---	deg	∅ = 90°	3
			23	---	---	deg	∅ = 270°	3
			30	---	---	deg	∅ = 0°	3
			56	---	---	deg	∅ = 180°	3

Note1: Definition of response time.

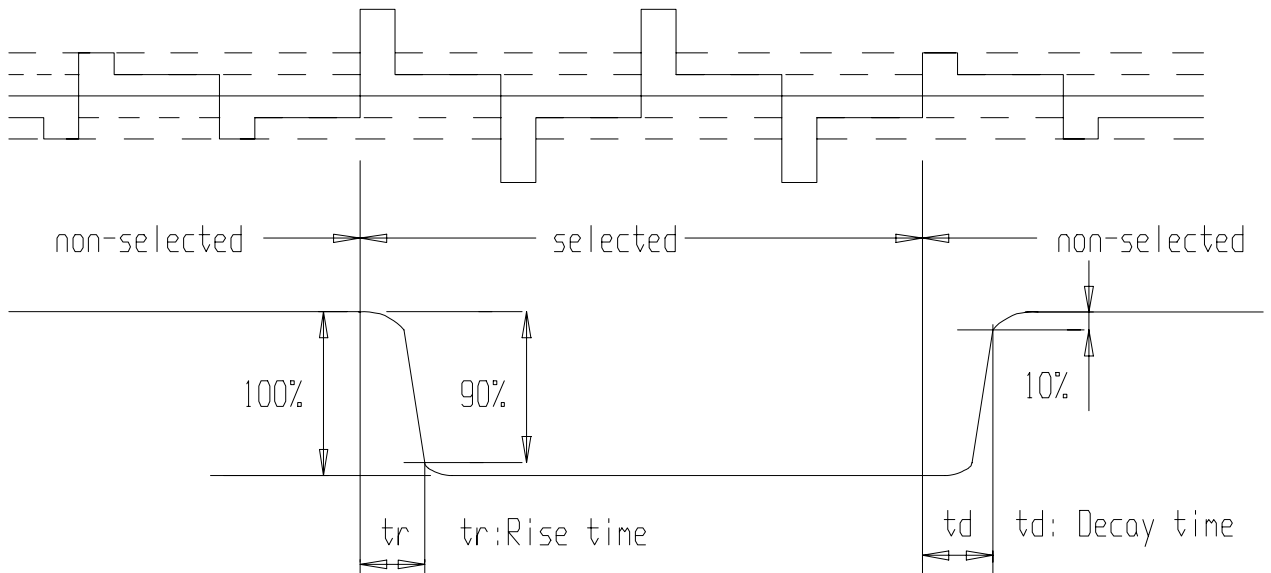

Note2: Definition of contrast ratio 'Cr' .

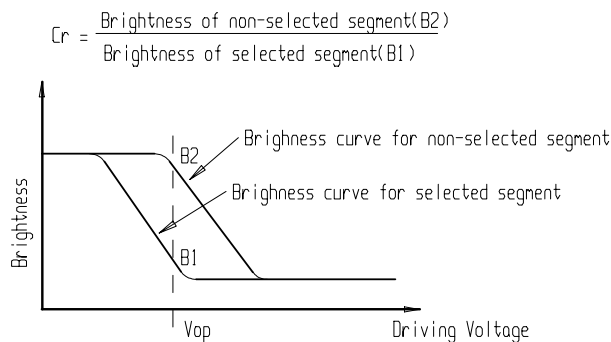

Note3: Definition of viewing angle.

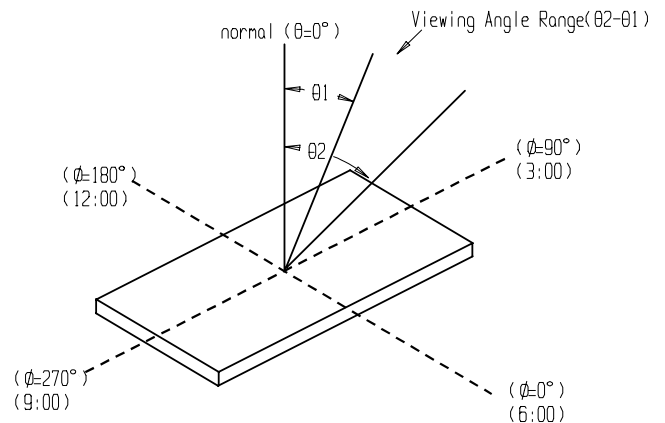

7. BLOCK DIAGRAM

1	2	3	4	5	6	7	8	9	10	11	12	13	14	15	16	17	18	19	20
VSS	VDD	VO	D/I	R/W	E	DB0	DB1	DB2	DB3	DB4	DB5	DB6	DB7	CS1	CS2	/RST	VEE	BLA	BLK

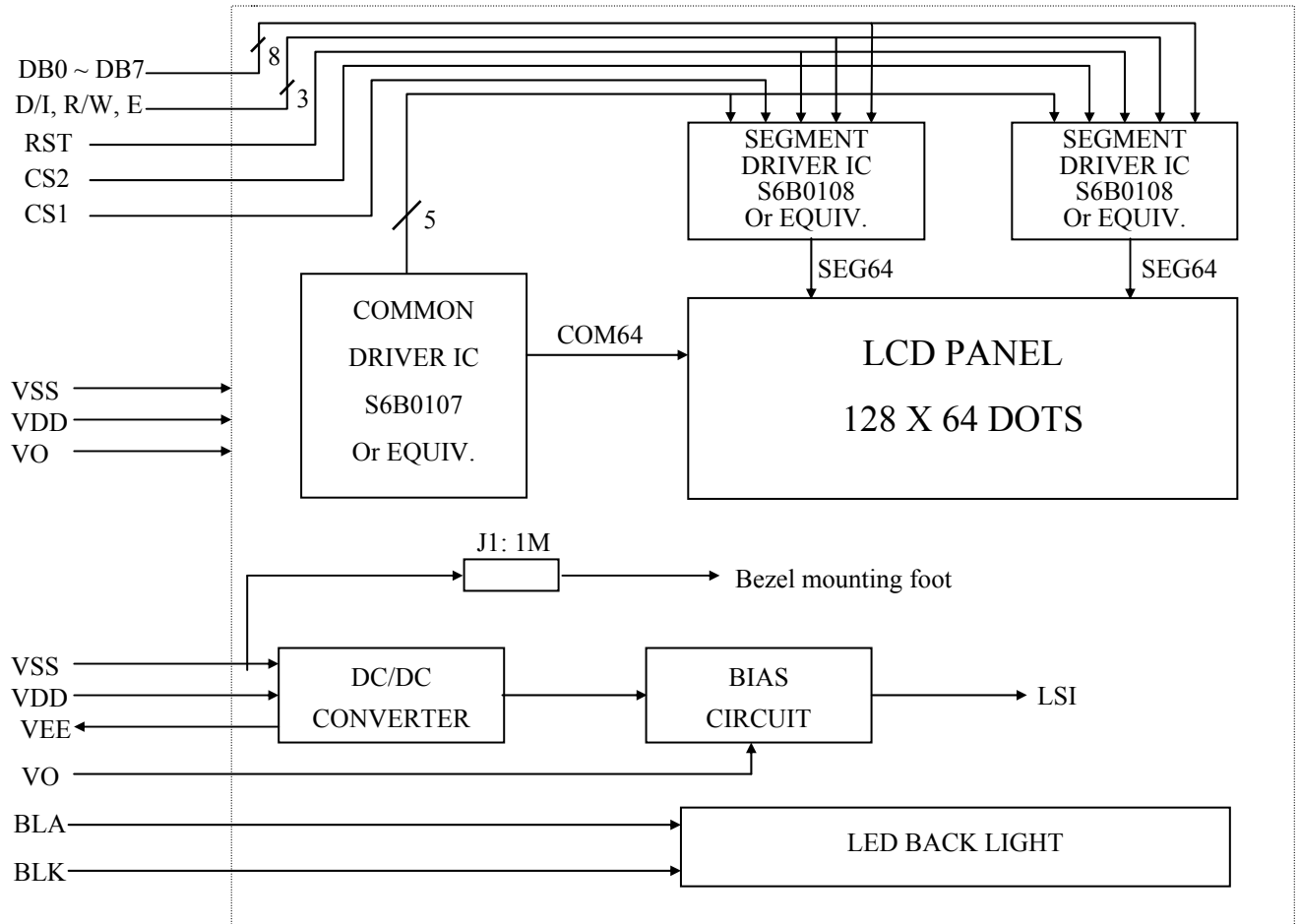

8. POWER SUPPLY

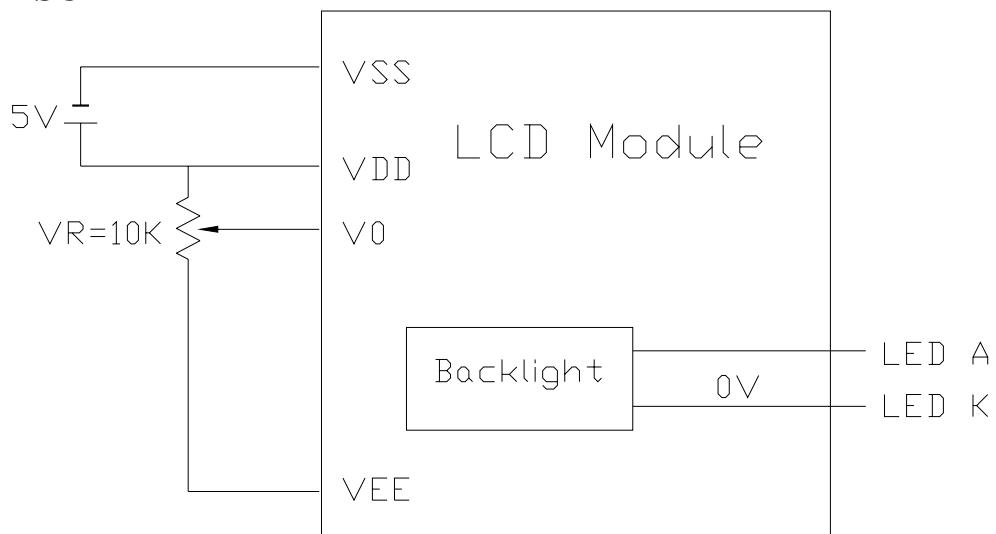

9. INTERFACE PIN CONNECTIONS

Pin No.	Symbol	Level	Description
1	VSS	0V	Ground
2	VDD	5.0V	Supply voltage for logic
3	VO	---	Input voltage for LCD
4	D/I	H/L	Data/Instruction signal
5	R/W	H/L	Read/Write signal
6	E	H, H → L	enable signal
7	DB0	H/L	Data Bus
8	DB1	H/L	
9	DB2	H/L	
10	DB3	H/L	
11	DB4	H/L	
12	DB5	H/L	
13	DB6	H/L	
14	DB7	H/L	
15	CS1	H	Chip select signal
16	CS2	H	Chip select signal
17	/RST	L	Reset signal
18	VEE	-5V	Voltage booster output
19	LEDA	4.2V	Back light anode
20	LEDK	0V	Back light cathode

10. BACK LIGHT SPECIFICATION

10.1 ABSOLUTE MAXIMUM RATINGS (Ta=25°C)

Item	Symbol	Condition	Rating	Unit
Reverse Voltage	Vr		10	V
Reverse Current	Ir		360	μA
Absolute maximum forward current	Ifm		720	mA
Peak forward current	Ifp	Imsec plus 10% Duty cycle	2160	mA
Power dissipation	Pd		3600	mW
Operating temperature range	Topr		-30~+70	°C
Storing temperature	Tst		-40~+80	°C

10.2 ELECTRICAL/OPTICAL CHARACTERISTICS (Ta=25°C, If=360mA)

Color	Peak wavelength λ_p (nm) (±5nm)	Spectral line half width $\Delta\lambda$ (nm)	Operating voltage(V) (±0.20V)	Forward Current(mA)
Yellow / Green	568	30	4.2	360

10.3 BLOCK DIAGRAM (2X36=72dies)

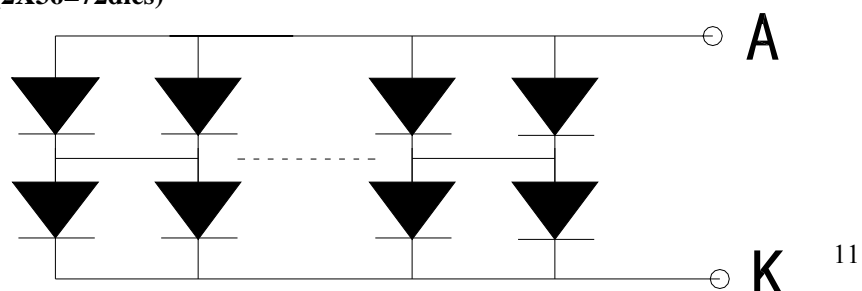

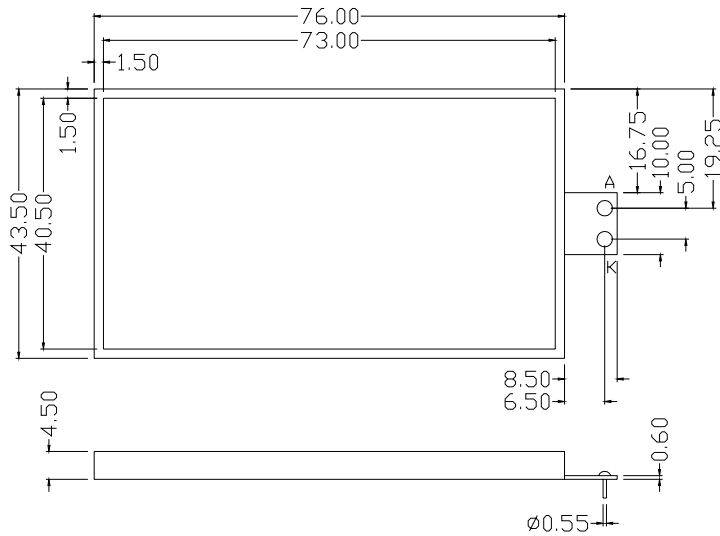
10.4 BACK LIGHT DRAWING (unite: mm, default tolerance: ±0.3mm)

11. PART LIST

ITEM	DESCRIPTION	QTY	UNIT
1	PCB, SIZE:93.0X70.0X1.6mm, FR4 NICKEL PLATE, GOLD FLASH	1	PC
2	BEZEL, SZIE:87.0X50X12.0mm, T=0.5mm; V.A 72.5X39.5mm , BLACK COATING	1	PC
3	LCD STN/Y-G/Positive/Transflective, WIDE TEMP. 6:00 O'clock	1	PC
4	ZEBRA CONNECTOR: YS TYPE, SIZE:76X2.5X6.4mm	2	PC
5	LCD DRIVER IC KS00107B---U1	1	PC
6	LCD DRIVER IC KS00108B---U2-U3	2	PC
7	DC/DC CONVERTOR NJU7660---U5	1	PC
8	CHIP RESISTOR, #0805 47K ohm, ±5%---R1,R10	2	PC
9	CHIP RESISTOR, #0805 2.2K ohm, ±5%---R4	1	PC
10	CHIP RESISTOR, #0805 150R ohm, ±5%---R8	1	PC
11	CHIP RESISTOR, #0805 1K ohm, ±5%---R2,R3,R5,R6	4	PC
12	CHIP RESISTOR, #0805 10K ohm, ±5%---R11	1	PC
13	CHIP RESISTOR, #0805 0 ohm, ±5%---R7,R12	2	PC
14	CHIP RESISTOR, #0603 0 ohm, ±5%---R16,R18,R20	3	PC
15	CHIP RESISTOR, #0805 1M ohm, ±5%---J1	1	PC
16	CHIP CAP, #0805 ±5% 20pF---C1	1	PC
17	CHIP CAP, #0805 +80%/-20% 0.1uF---CP1-CP5,C7	6	PC
18	CHIP CAP, #0805 +80%/-20% 4.7uF---C2	1	PC
19	CHIP CAP, #1206 +80%/-20% 4.7uF---C3	1	PC
20	CHIP TAN-CAP, A Size, ±20% 10uF/16V---C5,C6	2	PC
21	Y-G COLOR BACKLIGHT, SIZE: 76X43.5X4.5mm	1	PC

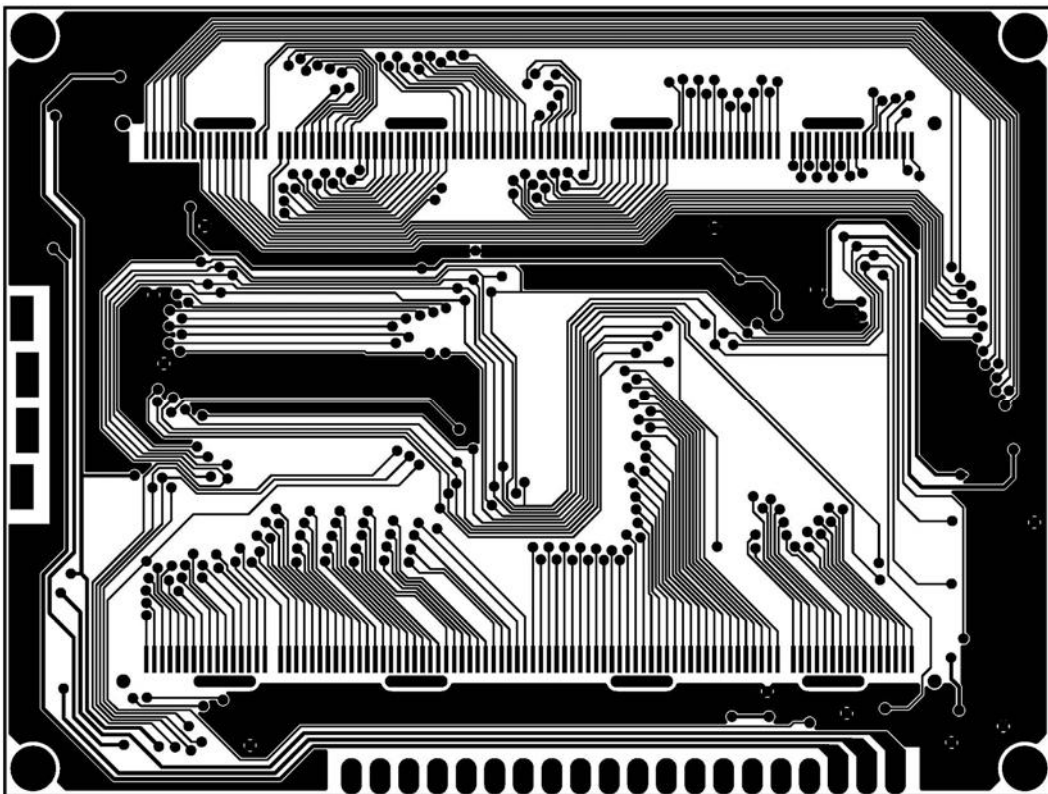
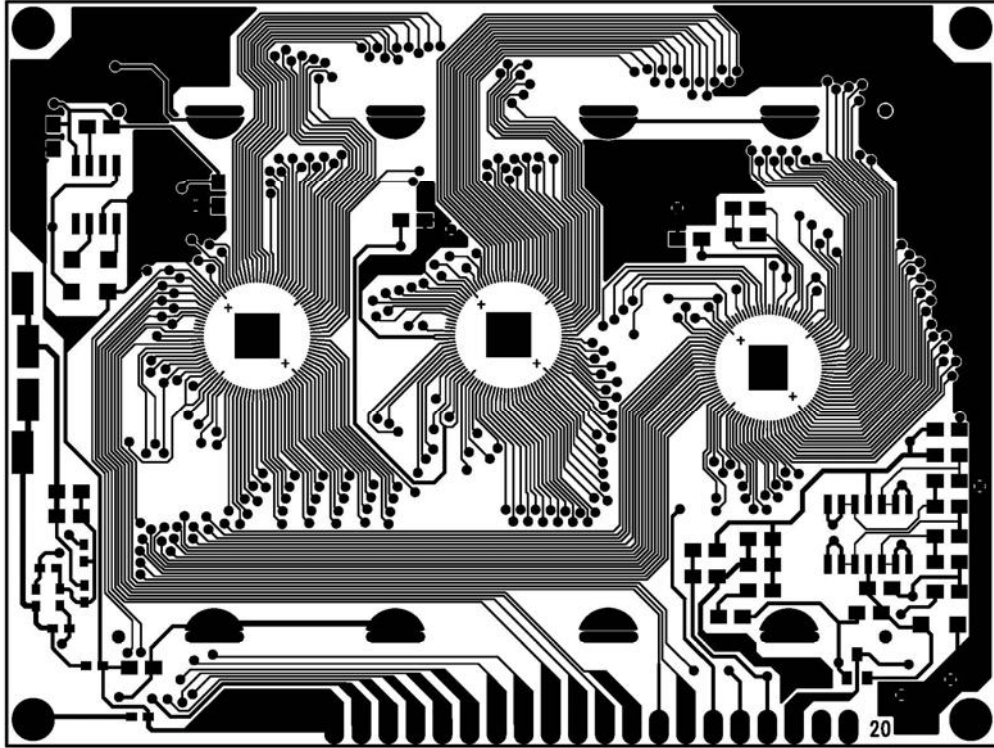
12. PCB CIRCUIT DRAWING AND LAYOUT

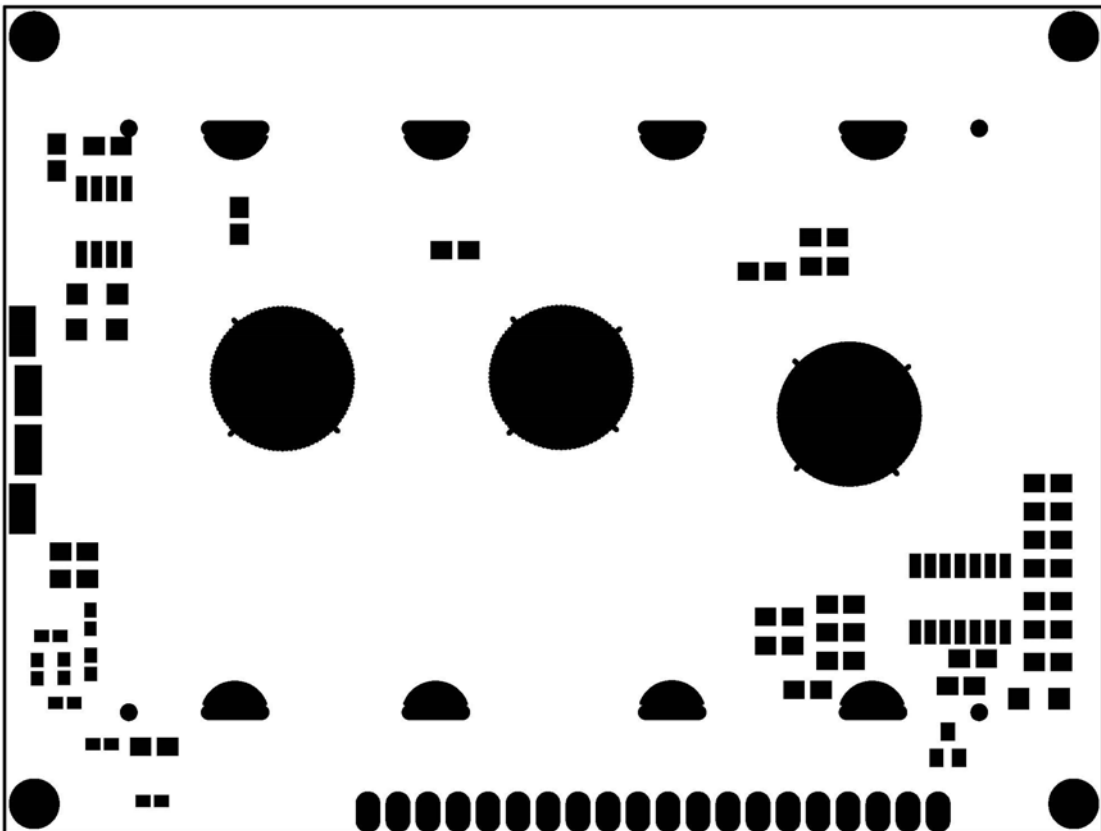
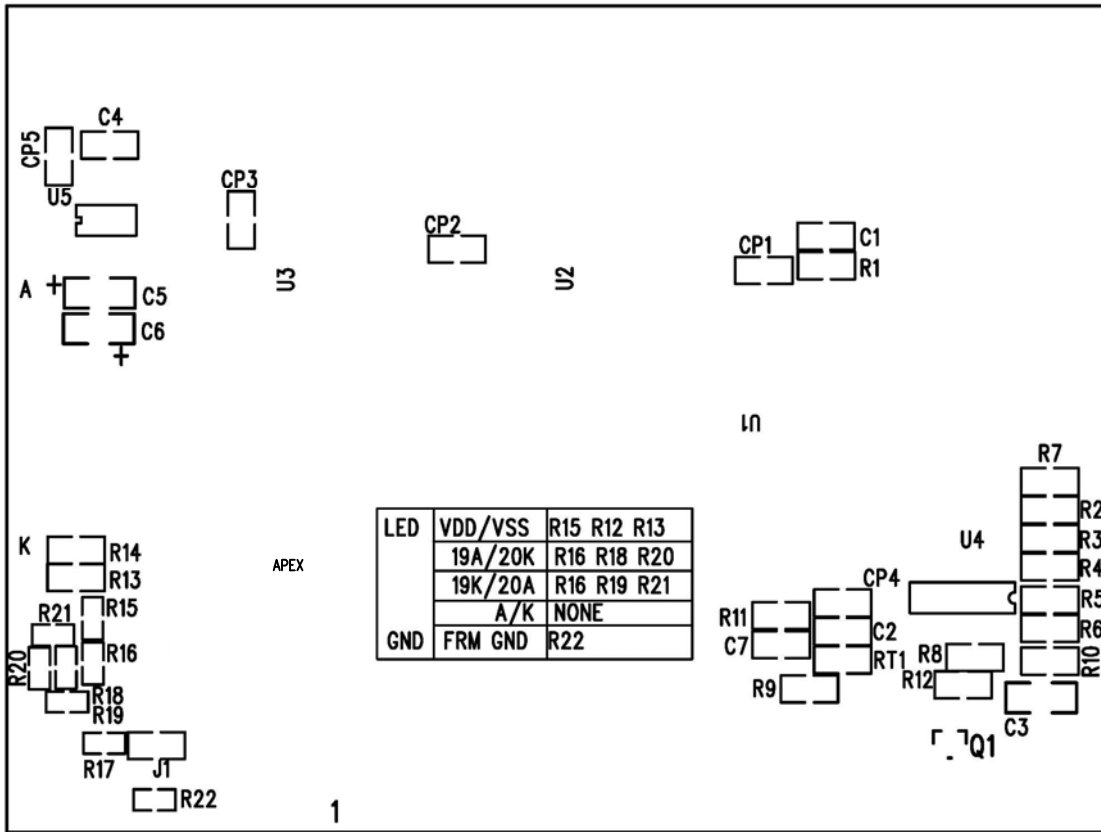

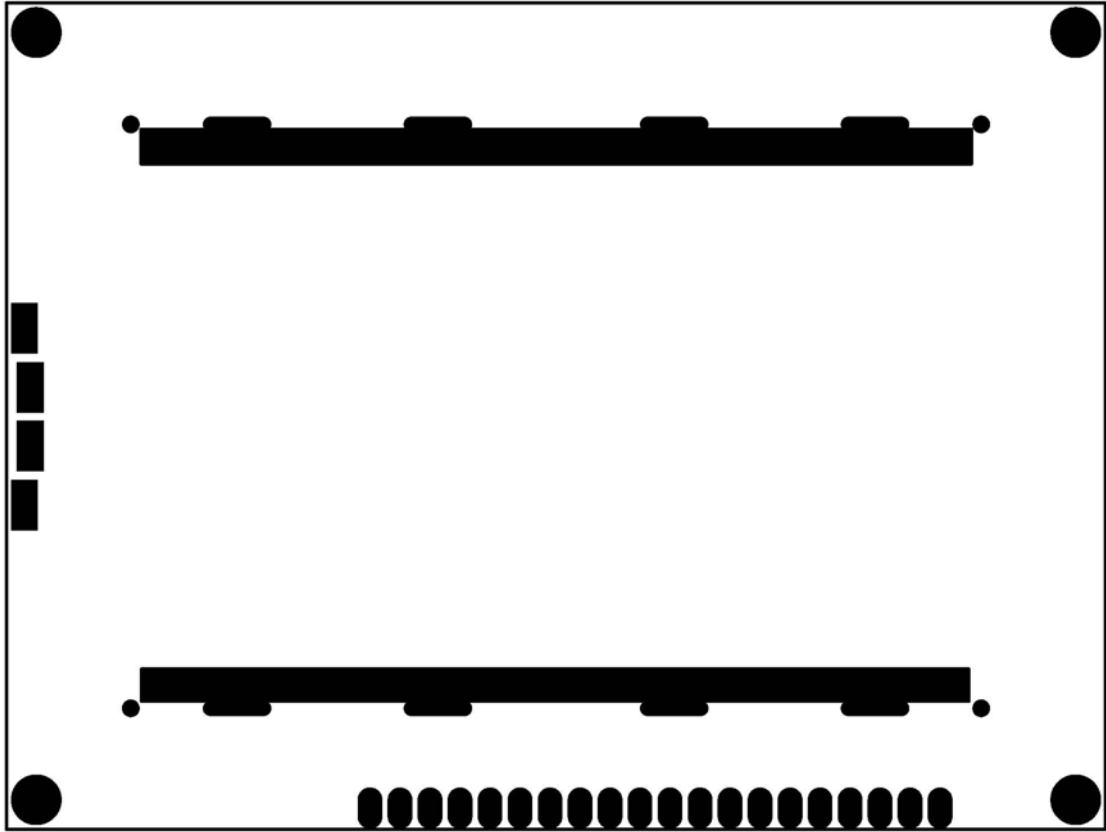



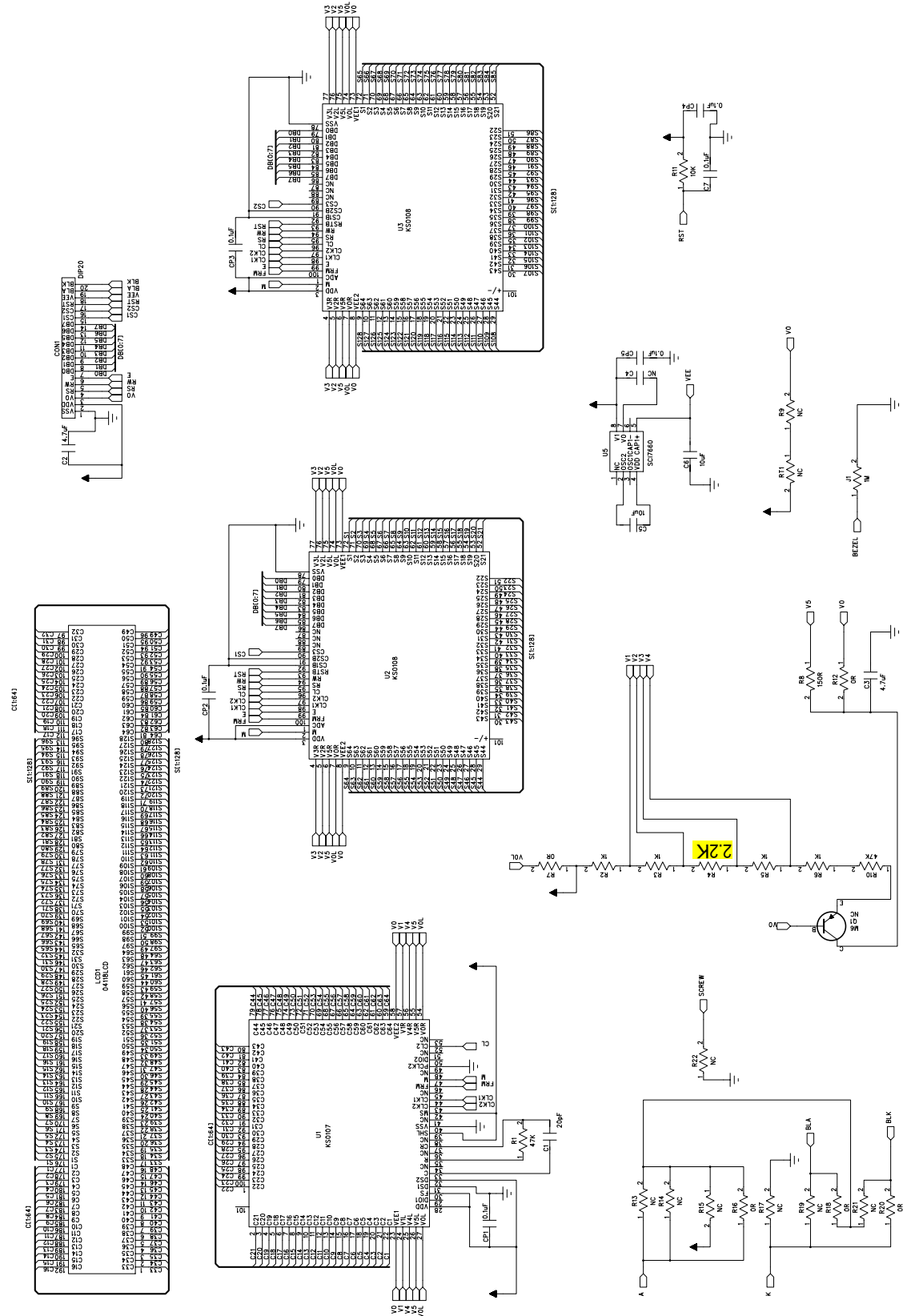

13. QUALITY ASSURANCE

13.1 Content of Reliability Test

Environmental Test				
No.	Test Item	Content of Test	Test Condition	Applicable Standard
1	High temperature storage	Endurance test applying the high storage temperature for a long time.	80 °C 96 hrs	-----
2	Low temperature storage	Endurance test applying the low storage temperature for a long time.	-30 °C 96 hrs	-----
3	High temperature operation	Endurance test applying the electric stress (Voltage & Current) and the thermal stress to the element for a long time.	70 °C 96 hrs	-----
4	Low temperature operation	Endurance test applying the electric stress under low temperature for a long time.	-20 °C 96 hrs	-----
5	High temperature / Humidity storage	Endurance test applying the high temperature and high humidity storage for a long time.	60 °C , 90 %RH 24 hrs	MIL-202E-103B JIS-C5023
6	High temperature / Humidity operation	Endurance test applying the electric stress (Voltage & Current) and temperature / humidity stress to the element for a long time.	40 °C , 90 %RH 24 hrs	MIL-202E-103B JIS-C5023
7	Temperature cycle	Endurance test applying the low and high temperature cycle. $ \begin{array}{ccccc} -20^{\circ}\text{C} & \rightleftharpoons & 25^{\circ}\text{C} & \rightleftharpoons & 70^{\circ}\text{C} \\ 30\text{min} & \xleftarrow{\hspace{1cm}} & 5\text{min.} & \xleftarrow{\hspace{1cm}} & 30\text{min} \\ & \xleftarrow{\hspace{2.5cm}} & & \xrightarrow{\hspace{2.5cm}} & \\ & \text{1 cycle} & & & \end{array} $	-----	
Mechanical Test				
8	Vibration test	Endurance test applying the vibration during transportation and using.	10~22Hz → 1.5mmp-p 22~500Hz → 1.5G Total 0.5hrs	MIL-202E-201A JIS-C5025 JIS-C7022-A-10
9	Shock test	Constructional and mechanical endurance test applying the shock during transportation.	50G half sign wave 11 msdc 3 times of each direction	MIL-202E-213B
10	Drop test	Endurance test applying the convey	Packed, 100CM free fall,(6sides,1 corner, 3edges)	

* Supply voltage for logic system = 5.0V. Supply voltage for LCD system = Operating voltage at 25°C.

* One single product test for only one item

* Judgment after test: keep in room temperature for more than 2 hours.

-Current consumption < 2 times of initial value

-Contrast > 1/2 initial value

-Function: work normally

13.2 Failure Judgment Criterion

Criterion Item	Test Item No.											Failure Judgment Criterion	
	1	2	3	4	5	6	7	8	9	10	11		
Basic specification													Out of the Basic Specification
Electrical characteristic													Out of the DC and AC Characteristic
Mechanical characteristic													Out of the Mechanical Specification Color change : Out of Limit Appearance Specification
Optical characteristic													Out of the Appearance Standard

13.3 Inspection conditions

13.3.1 Inspection conditions

The LCD shall be inspected under 40W white fluorescent light.

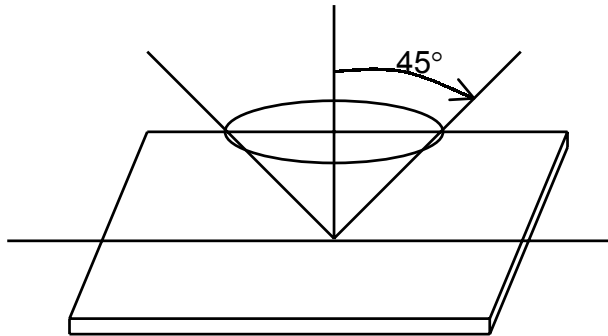

13.3.2 Definition of applicable Zones

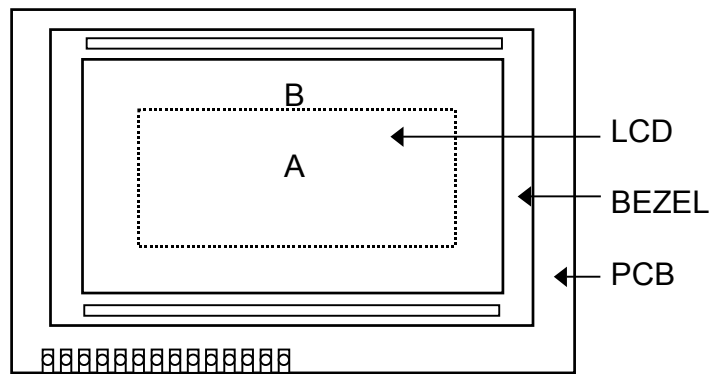

A : Display Area
B : Non-Display Area

13.3.3 Inspection Parameters

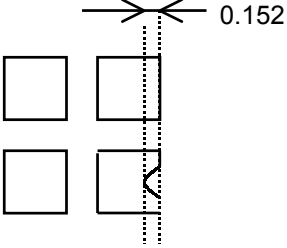
No.	Parameter	Criteria																												
1	Black or White spots	<table border="1"> <thead> <tr> <th rowspan="2">Zone Dimension</th> <th colspan="2">Acceptable number</th> <th rowspan="2">Class Of Defects</th> <th rowspan="2">AQL Level</th> </tr> <tr> <th>A</th> <th>B</th> </tr> </thead> <tbody> <tr> <td>D < 0.15</td> <td>*</td> <td>*</td> <td rowspan="4">Minor</td> <td rowspan="4">2.5</td> </tr> <tr> <td>0.15 ≤ D < 0.2</td> <td>4</td> <td>4</td> </tr> <tr> <td>0.2 ≤ D ≤ 0.25</td> <td>2</td> <td>2</td> </tr> <tr> <td>D ≤ 0.3</td> <td>0</td> <td>1</td> </tr> </tbody> </table> <p style="text-align: center;">D = (Long + Short) / 2 * : Disregard</p>	Zone Dimension	Acceptable number		Class Of Defects	AQL Level	A	B	D < 0.15	*	*	Minor	2.5	0.15 ≤ D < 0.2	4	4	0.2 ≤ D ≤ 0.25	2	2	D ≤ 0.3	0	1							
Zone Dimension	Acceptable number			Class Of Defects	AQL Level																									
	A	B																												
D < 0.15	*	*	Minor	2.5																										
0.15 ≤ D < 0.2	4	4																												
0.2 ≤ D ≤ 0.25	2	2																												
D ≤ 0.3	0	1																												
2	Scratch, Substances	<table border="1"> <thead> <tr> <th colspan="2">Zone</th> <th colspan="2">Acceptable number</th> <th rowspan="2">Class Of Defects</th> <th rowspan="2">AQL Level</th> </tr> <tr> <th>X (mm)</th> <th>Y (mm)</th> <th>A</th> <th>B</th> </tr> </thead> <tbody> <tr> <td>*</td> <td>0.04 ≥ W</td> <td>*</td> <td>*</td> <td rowspan="4">Minor</td> <td rowspan="4">2.5</td> </tr> <tr> <td>3.0 ≥ L</td> <td>0.06 ≥ W</td> <td>4</td> <td>4</td> </tr> <tr> <td>2.0 ≥ L</td> <td>0.08 ≥ W</td> <td>2</td> <td>3</td> </tr> <tr> <td>—</td> <td>0.1 < W</td> <td>0</td> <td>1</td> </tr> </tbody> </table> <p style="text-align: center;">X : Length Y : Width * : Disregard Total defects should not exceed 4/module</p>	Zone		Acceptable number		Class Of Defects	AQL Level	X (mm)	Y (mm)	A	B	*	0.04 ≥ W	*	*	Minor	2.5	3.0 ≥ L	0.06 ≥ W	4	4	2.0 ≥ L	0.08 ≥ W	2	3	—	0.1 < W	0	1
Zone		Acceptable number		Class Of Defects	AQL Level																									
X (mm)	Y (mm)	A	B																											
*	0.04 ≥ W	*	*	Minor	2.5																									
3.0 ≥ L	0.06 ≥ W	4	4																											
2.0 ≥ L	0.08 ≥ W	2	3																											
—	0.1 < W	0	1																											
3	Air Bubbles (between glass & polarizer)	<table border="1"> <thead> <tr> <th rowspan="2">Zone Dimension</th> <th colspan="2">Acceptable number</th> <th rowspan="2">Class of Defects</th> <th rowspan="2">AQL Level</th> </tr> <tr> <th>A</th> <th>B</th> </tr> </thead> <tbody> <tr> <td>D ≤ 0.15</td> <td>*</td> <td>*</td> <td rowspan="3">Minor</td> <td rowspan="3">2.5</td> </tr> <tr> <td>0.15 < D ≤ 0.25</td> <td>2</td> <td>*</td> </tr> <tr> <td>0.25 < D</td> <td>0</td> <td>1</td> </tr> </tbody> </table> <p style="text-align: center;">* : Disregard Total defects shall not excess 3/module.</p>	Zone Dimension	Acceptable number		Class of Defects	AQL Level	A	B	D ≤ 0.15	*	*	Minor	2.5	0.15 < D ≤ 0.25	2	*	0.25 < D	0	1										
Zone Dimension	Acceptable number			Class of Defects	AQL Level																									
	A	B																												
D ≤ 0.15	*	*	Minor	2.5																										
0.15 < D ≤ 0.25	2	*																												
0.25 < D	0	1																												
4	Uniformity of Pixel	<p>(1) Pixel shape (with Dent)</p> 																												

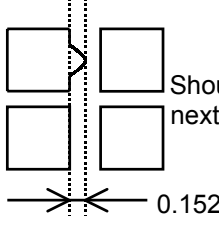
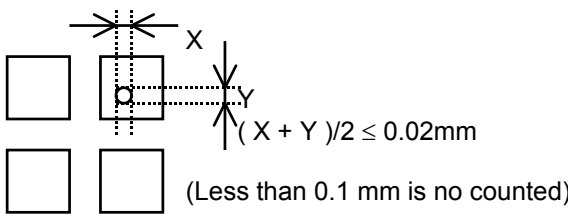
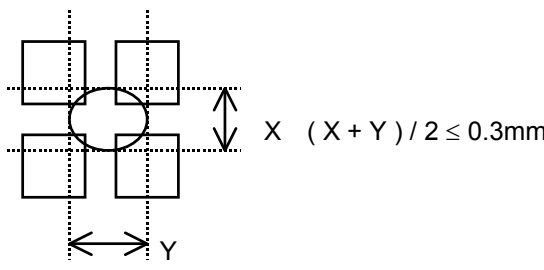
4	Uniformity of Pixel	<p>(2) Pixel shape (with Projection)</p>  <p>Should not be connected to next pixel</p> <p>0.152</p> <p>(3) Pin hole</p>  <p>$(X + Y) / 2 \leq 0.02\text{mm}$</p> <p>(Less than 0.1 mm is no counted)</p> <p>(4) Deformation</p>  <p>$X (X + Y) / 2 \leq 0.3\text{mm}$</p> <p>Total acceptable number : 1/pixel, 5/cell</p>	
Class of defects	Major	AQL 0.65%	<p>Definition</p> <p>It is a defect that is likely to result in failure or to reduce materially the usability of the product for the intended function.</p>
		AQL 1.00%	It is a defect that is likely to assembly size and not result in functioning problem.
	Minor	AQL 2.5%	It is a defect that will not result in functioning problem with deviation classified.

14. PRECAUTIONS IN USING LCM

1. LIQUID CRYSTAL DISPLAY (LCD)

LCD is made up of glass, organic sealant, organic fluid, and polymer based polarizers. The following precautions should be taken when handling,

- (1). Keep the temperature within range of use and storage. Excessive temperature and humidity could cause polarization degradation, polarizer peel off or bubble.
- (2). Do not contact the exposed polarizers with anything harder than an HB pencil lead. To clean dust off the display surface, wipe gently with cotton, chamois or other soft material soaked in petroleum benzin.
- (3). Wipe off saliva or water drops immediately. Contact with water over a long period of time may cause polarizer deformation or color fading, while an active LCD with water condensation on its surface will cause corrosion of ITO electrodes.
- (4). Glass can be easily chipped or cracked from rough handling, especially at corners and edges.
- (5). Do not drive LCD with DC voltage.

2. Liquid Crystal Display Modules

2.1 Mechanical Considerations

LCM are assembled and adjusted with a high degree of precision. Avoid excessive shocks and do not make any alterations or modifications. The following should be noted.

- (1). Do not tamper in any way with the tabs on the metal frame.
- (2). Do not modify the PCB by drilling extra holes, changing its outline, moving its components or modifying its pattern.
- (3). Do not touch the elastomer connector, especially insert an backlight panel (for example, EL).
- (4). When mounting a LCM make sure that the PCB is not under any stress such as bending or twisting. Elastomer contacts are very delicate and missing pixels could result from slight dislocation of any of the elements.
- (5). Avoid pressing on the metal bezel, otherwise the elastomer connector could be deformed and lose contact, resulting in missing pixels.

2.2. Static Electricity

LCM contains CMOS LSI's and the same precaution for such devices should apply, namely

- (1). The operator should be grounded whenever he/she comes into contact with the module. Never touch any of the conductive parts such as the LSI pads, the copper leads on the PCB and the interface terminals with any parts of the human body.
- (2). The modules should be kept in antistatic bags or other containers resistant to static for storage.
- (3). Only properly grounded soldering irons should be used.
- (4). If an electric screwdriver is used, it should be well grounded and shielded from commutator sparks.

- (5) The normal static prevention measures should be observed for work clothes and working benches; for the latter conductive (rubber) mat is recommended.
- (6). Since dry air is inductive to statics, a relative humidity of 50-60% is recommended.

2.3 Soldering

- (1). Solder only to the I/O terminals.
- (2). Use only soldering irons with proper grounding and no leakage.
- (3). Soldering temperature : $280^{\circ}\text{C} \pm 10^{\circ}\text{C}$
- (4). Soldering time: 3 to 4 sec.
- (5). Use eutectic solder with resin flux fill.
- (6). If flux is used, the LCD surface should be covered to avoid flux spatters. Flux residue should be removed after wards.

2.4 Operation

- (1). The viewing angle can be adjusted by varying the LCD driving voltage V_0 .
- (2). Driving voltage should be kept within specified range; excess voltage shortens display life.
- (3). Response time increases with decrease in temperature.
- (4). Display may turn black or dark blue at temperatures above its operational range; this is (however not pressing on the viewing area) may cause the segments to appear "fractured".
- (5). Mechanical disturbance during operation (such as pressing on the viewing area) may cause the segments to appear "fractured".

2.5 Storage

If any fluid leaks out of a damaged glass cell, wash off any human part that comes into contact with soap and water. Never swallow the fluid. The toxicity is extremely low but caution should be exercised at all the time.

2.6 Limited Warranty

Unless otherwise agreed between APEX and customer, APEX will replace or repair any of its LCD and LCM which is found to be defective electrically and visually when inspected in accordance with APEX acceptance standards, for a period on one year from date of shipment. Confirmation of such date shall be based on freight documents. The warranty liability of APEX is limited to repair and/or replacement on the terms set forth above. APEX will not responsible for any subsequent or consequential events.

15. DIMENSIONAL OUTLINE

CUSTOMER'S APPROVED:	DATE:	PAGE:1/1
-----------------------------	--------------	-----------------

SPECIFICATION:

1. Display Mode :STN/Positive/Y-G/Transflective
2. Drive Condition :1/64 Duty,1/9 Bias, V_{DP}=5.0V, V_{OP}=9.3V
3. Viewing angle: 6 O'clock
4. Operating temp. : -20~+70° C
Storage temp. : -30~+80° C
5. LCD controller : KS00107B & KS00108B
6. LED Backlight : Yellow-Green, If=360mA(VF:4.2V)
7. Dimensions with mark "*"are important.
8. RoHS compliant

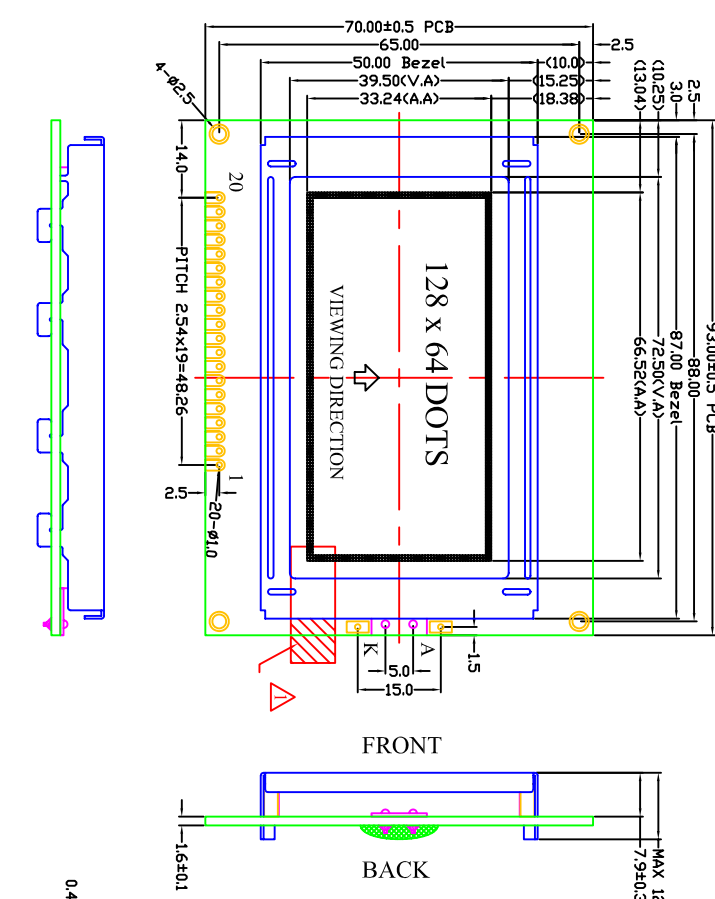

FRONT

BACK

CIRCUIT DIAGRAM
(LED Array 2*36=72 DICES)
Color: Yellow-Green
If=360mA, Vf=4.2±0.2V

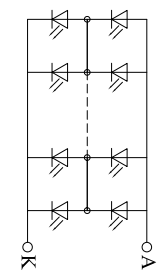

DOT DETAIL
SCALE:5/1

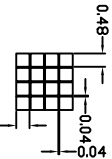

PIN ASSIGNMENT

PIN	1	2	3	4	5	6	7	8	9	10
DESC	VSS	VDD	VO	D/I	R/W	E	DB0	DB1	DB2	DB3
PIN	11	12	13	14	15	16	17	18	19	20
DESC	DB4	DB5	DB6	DB7	CS1	CS2	RST	VEE	LEDA	LEBK

DESCRIPTION:

REV	DESCRIPTION:	DATE
A00	First issue	Jul-27-2007
A01	Add Stripper and soldering one foot	Jul-31-2007

MODEL No. AX07023-01

APEX DISPLAY LIMITED

Unit: mm

Chk: Peter Li

App: Vincent

DESCRIPTION: C/D

GENERAL TOL: ±0.3

DO NOT SCALE THIS DRAWING.

APEX DISPLAY LIMITED

Chk: Peter Li

App: Vincent

16. PACKAGE INFORMATION

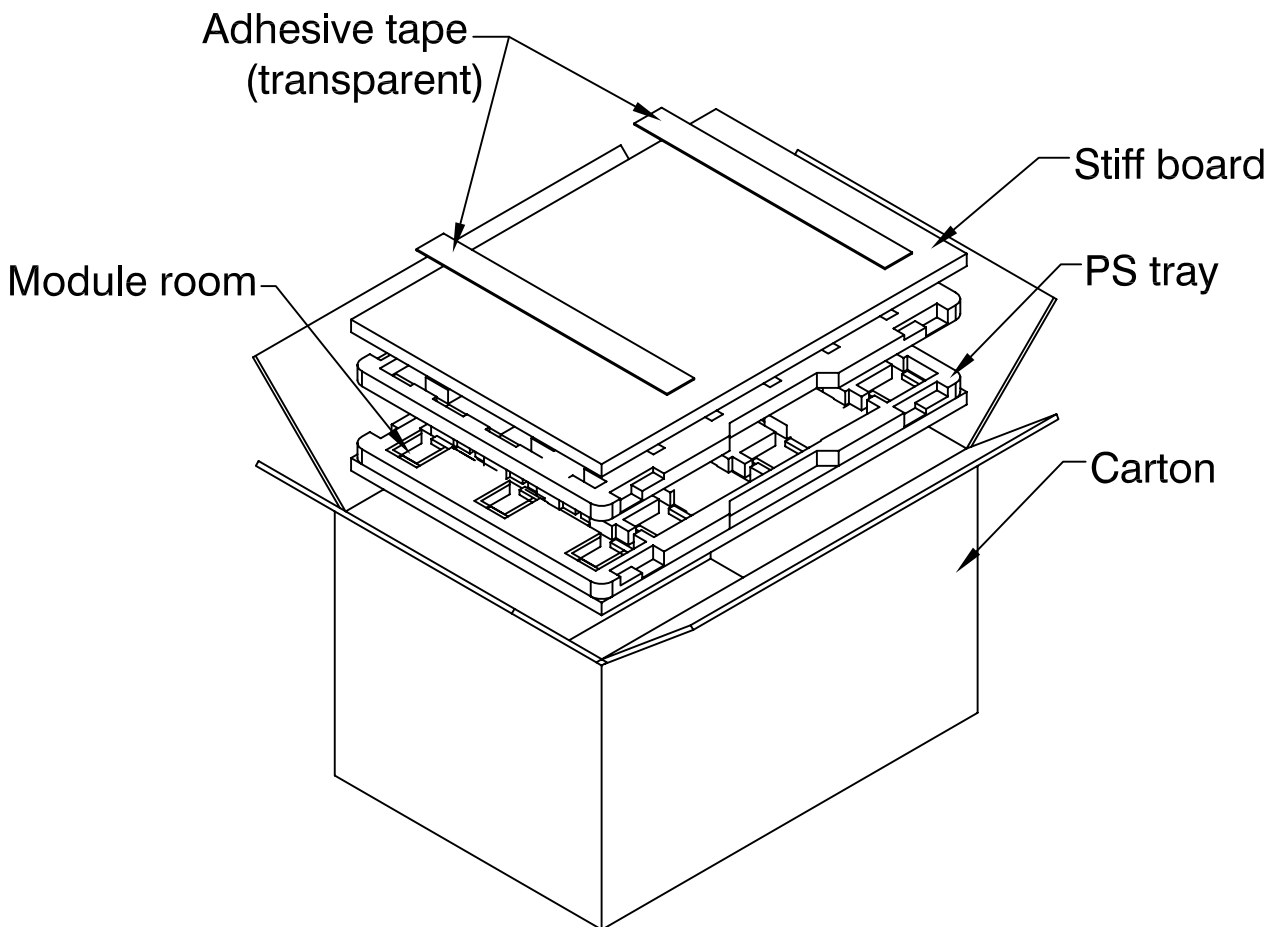

Note:

Modules live in module room in every PS tray. An anti-static pad is added on the top PS tray. On the bottom and top side a stiff board is added to stiffen the packings. Then using adhesive tape for enlacing.

One carton outline dimension is 400X350X415mm.

All packing material must meet for RoHS.

17. USING LCD MODULES

17.1 Liquid Crystal Display Modules

LCD is composed of glass and polarizer. Pay attention to the following items when handling.

- (1) Please keep the temperature within specified range for use and storage. Polarization degradation, bubble generation or polarizer peel-off may occur with high temperature and high humidity.
- (2) Do not touch, push or rub the exposed polarizer with anything harder than an HB pencil lead (glass, tweezers, etc.).
- (3) N-hexane is recommended for cleaning the adhesives used to attach front/rear polarizer and reflectors made of organic substances which will be damaged by chemicals such as acetone, toluene, ethanol and isopropyl alcohol.
- (4) When the display surface becomes dusty, wipe gently with absorbent cotton or other soft material like chamois soaked in petroleum benign. Do not scrub hard to avoid damaging the display surface.
- (5) Wipe off saliva or water drops immediately, contact with water over a long period of time may cause deformation or color fading.
- (6) Avoid contacting oil and fats.
- (7) Condensation on the surface and contact with terminals due to cold will damage, stain or dirty the polarizer. After products are tested at low temperature they must be warmed up in a container before coming is contacting with room temperature air.
- (8) Do not put or attach anything on the display area to avoid leaving marks on.
- (9) Do not touch the display with bare hands. This will stain the display area and depredate insulation between terminals (some cosmetics are determinate to the polarizer).
- (10) As glass is fragile. It tends to become or chipped during handling especially on the edges. Please avoid dropping or jarring.

17.2 Installing LCD Modules

The hole in the printed circuit board is used to fix LCM as shown in the picture below. Attend to the following items when installing the LCM.

- (1) Cover the surface with a transparent protective plate to protect the polarizer and LC cell.

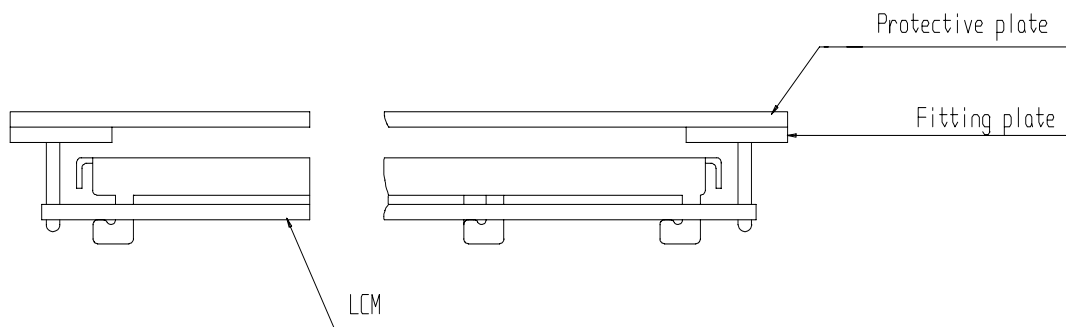

- (2) When assembling the LCM into other equipment, the spacer to the bit between the LCM and the fitting plate should have enough height to avoid causing stress to the module surface, refer to the individual specifications for measurements. The measurement tolerance should be ± 0.1 mm.

17.3 Precaution for Handling LCD Modules

Since LCM has been assembled and adjusted with a high degree of precision, avoid applying excessive shocks to the module or making any alterations or modifications to it.

- (1) Do not alter, modify or change the shape of the tab on the metal frame.
- (2) Do not make extra holes on the printed circuit board, modify its shape or change the positions of components to be attached.
- (3) Do not damage or modify the pattern writing on the printed circuit board.
- (4) Absolutely do not modify the zebra rubber strip (conductive rubber) or heat seal connector.
- (5) Except for soldering the interface, do not make any alterations or modifications with a soldering iron.
- (6) Do not drop, bend or twist LCM.

17.4 Electro-Static Discharge Control

Since this module uses a CMOS LSI, the same careful attention should be paid to electrostatic discharge as for an ordinary CMOS IC.

- (1) Make certain that you are grounded when handling LCM.
- (2) Before remove LCM from its packing case or incorporating it into a set, be sure the module and your body have the same electric potential.
- (3) When soldering the terminal of LCM, make certain the AC power source for the soldering iron does not leak.
- (4) When using an electric screwdriver to attach LCM, the screwdriver should be of ground potentiality to minimize as much as possible any transmission of electromagnetic waves produced sparks coming from the commentator of the motor.
- (5) As far as possible make the electric potential of your work clothes and that of the work bench the ground potential.
- (6) To reduce the generation of static electricity is careful that the air in the work is not too dried. A relative humidity of 50%-60% is recommended.

17.5 Precaution for soldering to the LCM

- (1) Observe the following when soldering lead wire, connector cable and etc. to the LCM.
 - Soldering iron temperature: $280^{\circ}\text{C} \pm 10^{\circ}\text{C}$.
 - Soldering time: 3-4 sec.
 - Solder: eutectic solder.

If soldering flux is used, be sure to remove any remaining flux after finishing to soldering operation. (This does not apply in the case of a non-halogen type of flux.) It is recommended that you protect the LCD surface with a cover during soldering to prevent any damage due to flux spatters.

(2) When soldering the electroluminescent panel and PC board, the panel and board should not be detached more than three times. This maximum number is determined by the temperature and time conditions mentioned above, though there may be some variance depending on the temperature of the soldering iron.

(3) When remove the electroluminescent panel from the PC board, be sure the solder has completely melted, the soldered pad on the PC board could be damaged.

17.6 Precautions for Operation

- (1) Viewing angle varies with the change of liquid crystal driving voltage (V_0). Adjust V_0 to show the best contrast.
- (2) Driving the LCD in the voltage above the limit shortens its life.
- (3) Response time is greatly delayed at temperature below the operating temperature range. However, this does not mean the LCD will be out of the order. It will recover when it returns to the specified temperature range.
- (4) If the display area is pushed hard during operation, the display will become abnormal. However, it will return to normal if it is turned off and then back on.
- (5) Condensation on terminals can cause an electrochemical reaction disrupting the terminal circuit. Therefore, it must be used under the relative condition of 40°C , 50% RH.
- (6) When turning the power on, input each signal after the positive/negative voltage becomes stable.

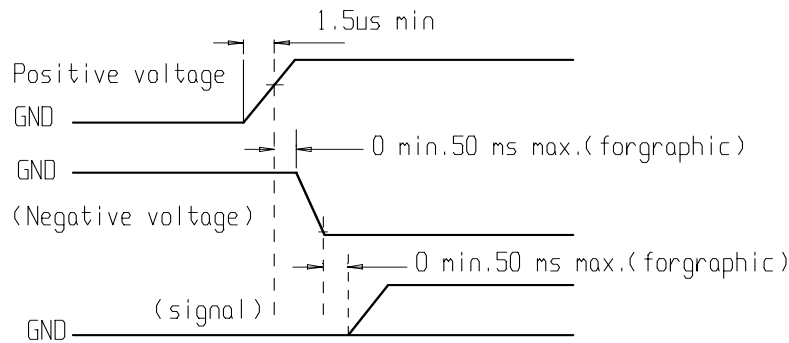

17.7 Storage

When storing LCD as spares for some years, the following precaution are necessary.

- (1) Store them in a sealed polyethylene bag. If properly sealed, there is no need for desiccant.
- (2) Store them in a dark place. Do not expose to sunlight or fluorescent light, keep the temperature between 0°C and 35°C.
- (3) The polarizer surface should not come in contact with any other objects. (We advise you to store them in the container in which they were shipped.)
- (4) Environmental conditions:
 - Do not leave them for more than 168hrs. At 60°C.
 - Should not be left for more than 48hrs. At -20°C.

17.8 Safety

- (1) It is recommended to crush damaged or unnecessary LCD into pieces and wash them off with solvents such as acetone and ethanol, which should later be burned.
- (2) If any liquid leaks out of a damaged glass cell and comes in contact with the hands, wash off thoroughly with soap and water.

17.9 Limited Warranty

Unless agreed between APEX and customer, APEX will replace or repair any of its LCD modules which are found to be functionally defective when inspected in accordance with APEX LCD acceptance standards (copies available upon request) for a period of **12 month** from date of shipments.

Cosmetic/visual defects must be returned to APEX within 90 days of shipment. Confirmation of such date shall be based on freight documents. The warranty liability of APEX limited to repair and/or replacement on the terms set forth above. APEX will not be responsible for any subsequent or consequential events.

17.10 Return LCM under warranty

No warranty can be granted if the precautions stated above have been disregarded. The typical examples of violations are:

- Broken LCD glass.
- PCB eyelet's damaged or modified.
- PCB conductors damaged.
- Circuit modified in any way, including addition of components.
- PCB tampered with by grinding, engraving or painting varnish.
- Soldering to or modifying the bezel in any manner.

Module repairs will be invoiced to the customer upon mutual agreement. Modules must be returned with sufficient description of the failures or defects. Any connectors or cable installed by the customer must be removed completely without damaging the PCB eyelet's, conductors and terminals.