

IPS Alpha Technology, Ltd.Date: Nov.26,2007**For Messrs. Matsushita Electric Group**
CUSTOMER'S ACCEPTANCE SPECIFICATIONS**Part Number:AX080A014B**
Matsushita Global Code: L5EDD8Q00038
Matsushita Issue Number: L20070399CONTENTS

No.	Item	Sheet No.	Page
-	COVER	IPS4PS 2601-AX080A014B-1	1-1/2~2/2
-	RECORD OF REVISION	IPS4PS 2602-AX080A014B-1	2-1/1
-	DESCRIPTION	IPS4PS 2603-AX080A014B-1	3-1/1
1	ABSOLUTE MAXIMUM RATINGS	IPS4PS 2604-AX080A014B-1	4-1/2~2/2
2	INITIAL OPTICAL CHARACTERISTICS	IPS4PS 2605-AX080A014B-1	5-1/3~3/3
3	ELECTRICAL CHARACTERISTICS	IPS4PS 2606-AX080A014B-1	6-1/2~2/2
4	BLOCK DIAGRAM	IPS4PS 2607-AX080A014B-1	7-1/1
5	INTERFACE PIN ASSIGNMENT	IPS4PS 2608-AX080A014B-1	8-1/6~6/6
6	INTERFACE TIMING	IPS4PS 2609-AX080A014B-1	9-1/3~3/3
7	DIMENSIONAL OUTLINE	IPS4PS 2610-AX080A014B-1	10-1/2~2/2
8	DESIGNATION OF LOT MARK	IPS4PS 2611-AX080A014B-1	11-1/2~2/2
9	COSMETIC SPECIFICATIONS	IPS4PS 2612-AX080A014B-1	12-1/3~3/3
10	PRECAUTION	IPS4PS 2613-AX080A014B-1	13-1/3~3/3
11	PACKING	IPS4PS 2614-AX080A014B-1	14-1/2~2/2
12	RELIABILITY TEST	IPS4PS 2615-AX080A014B-1	15-1/1

Please return 1 copy with your signature on this page for approval.

Accepted by: _____

Proposed by: K. Ashizawa

Date: _____

Matsushita Electric Group

Checklist of the items in the panasonic standard delivery specifications

Please check if the delivery specifications include the following items.
(If a listed item is not included, please make sure to describe the reason why it has not been included.)

Ver.1.1

No.	Item description	Listing check			Reason for not including (Ex Under research, confidential)
1	Part No. reference table (The global part No. and manufacturer part No. must be listed for series part numbers)	<input type="checkbox"/> Yes	<input type="checkbox"/> No	<input checked="" type="checkbox"/> N/A	
2	Part number structure (List the type, constant, class etc for a series part No.)	<input type="checkbox"/> Yes	<input type="checkbox"/> No	<input checked="" type="checkbox"/> N/A	
3	Place of production, factory name, country of origin	<input checked="" type="checkbox"/> Yes	<input type="checkbox"/> No	<input type="checkbox"/> N/A	
4	Electrical characteristics (Measuring circuit, measurement condition, dielectric strength, surge voltage, insulation resistance, rates capacity etc.)	<input checked="" type="checkbox"/> Yes	<input type="checkbox"/> No	<input type="checkbox"/> N/A	
5	Mechanical characteristics (Test method, terminal strength, tensile strength, anti-vibration, solder heat resistance, ease of soldering etc.)	<input checked="" type="checkbox"/> Yes	<input type="checkbox"/> No	<input type="checkbox"/> N/A	
6	External shape/dimensions (External shape drawing, simensions with tolerance)	<input checked="" type="checkbox"/> Yes	<input type="checkbox"/> No	<input type="checkbox"/> N/A	
7	Structure/material (Construction, material)	<input type="checkbox"/> Yes	<input checked="" type="checkbox"/> No	<input type="checkbox"/> N/A	
8	Functions (Semiconductor parts must include the functions)	<input checked="" type="checkbox"/> Yes	<input type="checkbox"/> No	<input type="checkbox"/> N/A	
9	Microcomputer performance (Microcomputer products must include the CPU bus width (bit))	<input type="checkbox"/> Yes	<input type="checkbox"/> No	<input checked="" type="checkbox"/> N/A	
10	Recommended circuit diagrams (Semiconductor parts must include a recommended circuit)	<input type="checkbox"/> Yes	<input type="checkbox"/> No	<input checked="" type="checkbox"/> N/A	
11	Pattern diagrams of PCB (Semiconductor parts must include the PCB patterns)	<input type="checkbox"/> Yes	<input type="checkbox"/> No	<input checked="" type="checkbox"/> N/A	
12	Environmental reliability warranty items (Anti-humidity, high/low temperature, thermal shock, life etc.)	<input checked="" type="checkbox"/> Yes	<input type="checkbox"/> No	<input type="checkbox"/> N/A	
13	Operating temperature range	<input checked="" type="checkbox"/> Yes	<input type="checkbox"/> No	<input type="checkbox"/> N/A	
14	Storage temperature range	<input checked="" type="checkbox"/> Yes	<input type="checkbox"/> No	<input type="checkbox"/> N/A	
15	Packaging specification (Simple package structure illustration, taping dimensions, stick dimensions, packaged quantity etc.)	<input checked="" type="checkbox"/> Yes	<input type="checkbox"/> No	<input type="checkbox"/> N/A	
16	Marking indication method	<input type="checkbox"/> Yes	<input checked="" type="checkbox"/> No	<input type="checkbox"/> N/A	
17	Strage period after opening (Semiconductor parts must include the storage environment and storage period after opening)	<input type="checkbox"/> Yes	<input checked="" type="checkbox"/> No	<input type="checkbox"/> N/A	
18	Precautions for use	<input checked="" type="checkbox"/> Yes	<input type="checkbox"/> No	<input type="checkbox"/> N/A	
19	Temperature profile (Solder flow and reflow temperature profile)	<input type="checkbox"/> Yes	<input type="checkbox"/> No	<input checked="" type="checkbox"/> N/A	
20	Failure rate (Exclude if it cannot be determined due to purchased item)	<input type="checkbox"/> Yes	<input checked="" type="checkbox"/> No	<input type="checkbox"/> N/A	
21	Safety standards (Conforming standard information, UL/CSA, electricity safety law, PL law etc.)	<input type="checkbox"/> Yes	<input checked="" type="checkbox"/> No	<input type="checkbox"/> N/A	
22	Process control chart	<input type="checkbox"/> Yes	<input checked="" type="checkbox"/> No	<input type="checkbox"/> N/A	
23	Export control checklist (Survey checklist against the export control law)	<input type="checkbox"/> Yes	<input checked="" type="checkbox"/> No	<input type="checkbox"/> N/A	
24	Items subject to advance discussions (Verify the statement that all changes to delivery specifications shall be notified in advance)	<input checked="" type="checkbox"/> Yes	<input type="checkbox"/> No	<input type="checkbox"/> N/A	
25	Manufacture's evaluation test data	<input type="checkbox"/> Yes	<input checked="" type="checkbox"/> No	<input type="checkbox"/> N/A	
26	Other materials determined necessary by the business unit	<input type="checkbox"/> Yes	<input checked="" type="checkbox"/> No	<input type="checkbox"/> N/A	
Disclosure/Non-disclosure (NDA, blanket contract, etc.)		<input checked="" type="checkbox"/> Disclosure	<input type="checkbox"/> Non-disclosure		
Description of intellectual property right		<input checked="" type="checkbox"/> No	<input type="checkbox"/> Yes		

RECORD OF REVISION

Date	The upper section : Previous revision The lower section : New revision		Summary
	Sheet No.	Page	

DESCRIPTION

The following specifications are applied to the following IPS-Pro-TFT LCD module.
Note : Inverter for back light unit is built in this module.

Product Name : AX080A014B

General Specifications

Effective Display Area	: (H)697.6845(V)392.256	(mm)
Number of Pixels	: (H) 1,366 × (V) 768	(pixels)
Pixel Pitch	: (H) 0.510 × (V) 0.510	(mm)
Color Pixel Arrangement	: R+G+B Vertical Stripe	
Display Mode	: Transmissive Mode Normally Black Mode	
Top Polarizer Type	: Anti-Glare	
Number of Colors	: 16,777,216	(colors)
Viewing Angle Range	: Super Wide Version (Horizontal & Vertical : 178°, CR ≥ 10)	
Input Signal	: 1-channel LVDS (LVDS : Low Voltage Differential Signaling)	
Back Light	: 18 pcs. of EEFL (EEFL : External Electrode Fluorescent Lamp)	
External Dimensions	: (H) 760.0 × (V) 450.0 × (t) 70.4	(mm)
Weight	: Typ. 7,000	(g)

1. ABSOLUTE MAXIMUM RATINGS

1.1 Environmental Absolute Maximum Ratings

ITEM	Operating		Storage		UNIT	NOTE
	Min.	Max.	Min.	Max.		
Temperature	0	50	-20	60	°C	1),5),6)
Humidity	2)		2)		%RH	1)
Vibration	-	4.9(0.5 G)	-	14.7(1.5 G)	m/s ²	3)
Shock	-	29.4(3 G)	-	294(30 G)	m/s ²	4)
Corrosive Gas	Not Acceptable		Not Acceptable		-	
Illumination at LCD Surface	-	50,000	-	50,000	lx	

- Note 1) Temperature and Humidity should be applied to the glass surface of a IPS-Pro TFT LCD module, not to the system installed with a module.
The brightness of a EEFL tends to drop at low temperature. Besides, the life-time becomes shorter at low temperature.
- 2) $T_a \leq 40\text{ }^\circ\text{C}$ ······Relative humidity should be less than 85 %RH max. Dew is prohibited.
 $T_a > 40\text{ }^\circ\text{C}$ ······Relative humidity should be lower than the moisture of the 85 %RH at 40 °C.

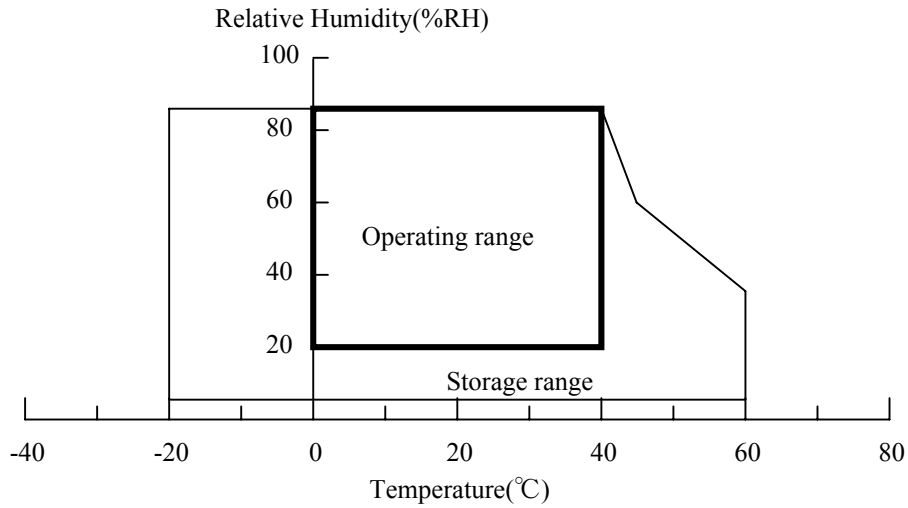

- 3) Frequency of the vibration is between 15 Hz and 100 Hz. (Remove the resonance point) 1 hour.
- 4) Pulse width of the shock is 10 ms.
- 5) Long operation under low temperature may cause some portion of display area to be reddish for several minutes after turning on the product.
However, it does not affect the characteristics and reliability of the product.
- 6) The temperature of LCD front surface would be 65 °C in operating, it may affect the optical characteristics however it does not damage the function of the module.

1. 2 Electrical Absolute Maximum Ratings

(1)TFT-LCD module

V_{SS} = 0 V

ITEM	SYMBOL	Min.	Max.	UNIT	NOTE
Power Supply Voltage	V _{DD}	0	13.2	V	
Input Voltage for logic	V _I	-0.3	4.0	V	1)
Electrostatic Durability	V _{ESD0}	±100		V	2),3)
	V _{ESD1}	±20		kV	2),4)

- Note 1) It is applied to pixel data signal and clock signal.
 2) Discharge Coefficient : 250 pF - 100 Ω, Environmental : 25 °C - 70%RH
 3) It is applied to I/F connector pins.
 4) It is applied to the surface of a metallic bezel and a LCD panel.

(2) Back light

GND = 0 V

ITEM	SYMBOL	Min.	Max.	UNIT	NOTE
Input Current	I _L	-	7.0	mArms	1)
Input Voltage	V _L	-	(3,000)	V _{rms}	2)

- Note 1) The specification shall be applied to each EEFL. The specification is defined at ground line.
 2) The specification shall be applied at connector pins for a EEFL at start-up.

(3) Back-light Inverter

GND = 0 V

ITEM	SYMBOL	Min.	Max.	UNIT	NOTE
Input Voltage	V _{in}	330	410	V	
IC Power Supply	V _{ic}	0	13.2	V	
ON/OFF Control Input Voltage	ON/OFF	0	7.0	V	
Analog Dimming	V _{adim}	0	7.0	V	
PWM signal voltage	V _{pwm}	0	7.0	V	

2. INITIAL OPTICAL CHARACTERISTICS

The following optical characteristics are measured under stable conditions. It takes about 30 minutes to reach stable conditions. The measuring point is the center of display area unless otherwise noted.

The optical characteristics should be measured in a dark room or equivalent state.

Measuring equipment : CS-1000A, or equivalent

Ambient Temperature =25 °C , VDD=12.0 V , f V=60 Hz ,

Vin=370 V , Adim=1.2 V , PWM on duty =95 %

ITEM		SYMBOL	CONDITION	Min.	Typ.	Max.	UNIT	NOTE			
Contrast Ratio		C R	$\theta = 0^\circ$ 1)	600	1100	-	-	2)			
Response Time	Rise	ton		-	8	20	ms	3)			
	Fall	toff		-	6	20	ms	3)			
Brightness of white		Bwh		400	500	-	cd/m ²				
Brightness uniformity		Buni		-	-	30	%	4)			
Color Chromaticity (CIE)	Red	χ	0.62	0.65	0.68	-	【Gray scale =255】				
		y	0.30	0.33	0.36						
	Green	χ	0.27	0.30	0.33						
		y	0.59	0.62	0.65						
	Blue	χ	0.12	0.15	0.18						
		y	0.04	0.07	0.10						
	White	χ	0.243	0.273	0.303						
		y	0.245	0.275	0.305						
Variation of Color Position (CIE)	Red	$\Delta \chi$	$\theta = +50^\circ$ $\phi = 0^\circ, 90^\circ, 180^\circ, 270^\circ$ 1)	-	-	0.04	-	5) 【Gray scale =255】			
		Δy		-	-	0.04					
	Green	$\Delta \chi$		-	-	0.04					
		Δy		-	-	0.04					
	Blue	$\Delta \chi$		-	-	0.04					
		Δy		-	-	0.04					
	White	$\Delta \chi$		-	-	0.04					
		Δy		-	-	0.04					
	Contrast Ratio at 89°			CR89	10	-			-	-	Estimated value
	Image sticking			-	Mosaic Pattern	invisible			-	6)	

Note 1) Definition of Viewing Angle

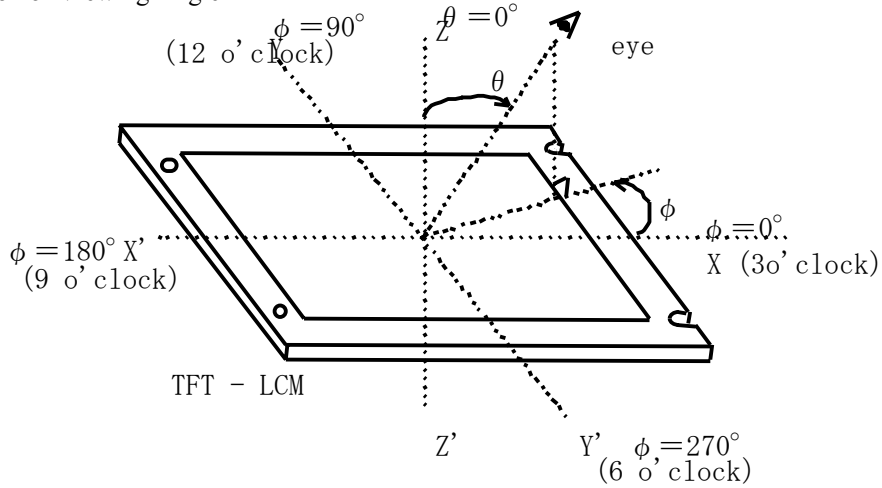

2) Definition of Contrast Ratio (CR)

$$CR = \frac{\text{(Luminance at displaying WHITE)}}{\text{(Luminance at displaying BLACK)}}$$

3) Definition of Response Time

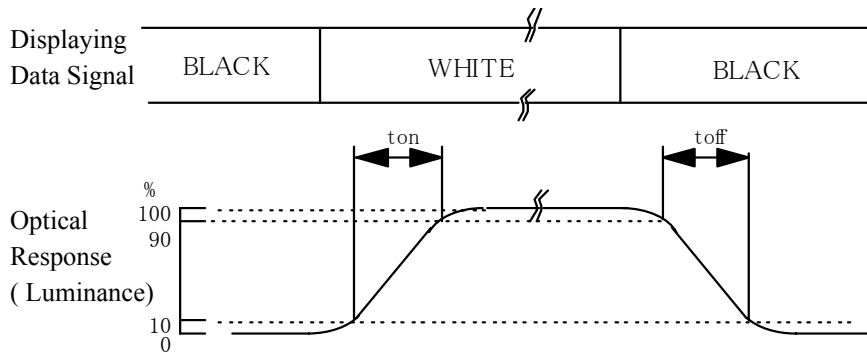

4) Definition of Brightness Uniformity

Display pattern is white (255 level). The brightness uniformity is defined as the following equation. Brightness at each point is measured, and average, maximum and minimum brightness is calculated.

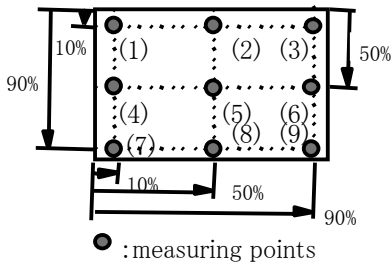

$$B_{uni} = \frac{|B_{max} \text{ or } B_{min} - B_{ave}|}{B_{ave}} \times 100$$

where, B_{max} = Maximum brightness

B_{min} = Minimum brightness

$$B_{ave} = \text{Average brightness} = \frac{\sum_{k=1}^9 (B(k))}{9}$$

5) Variation of color position on CIE

Variation of color position on CIE is defined as difference between colors at $\theta=0^\circ$ and at $\theta = 50^\circ$ & $\phi = 0^\circ, 90^\circ, 180^\circ, 270^\circ$.

6) Image Sticking

Mosaic pattern

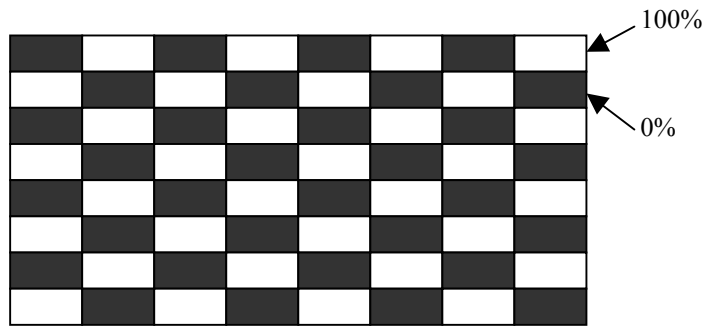

Condition : Operating mosaic pattern for 2 hours and gray scale (22 %) for 1 hour.

3. ELECTRICAL CHARACTERISTICS

3.1 TFT-LCD Module

Ta = 25 °C , Vss = 0 V

ITEM	SYMBOL	Min.	Typ.	Max.	UNIT	NOTE
Power supply Voltage	VDD	11.4	12.0	12.6	V	
Power supply Current	IDD	-	0.4	0.7	A	1),2)
Ripple voltage of power Supply	VDDR	-	-	350	mV	

Note 1) f V = 60.0 Hz , f CLK = 85 MHz , VDD = 12.0 V , and Display pattern is horizontal stripe.

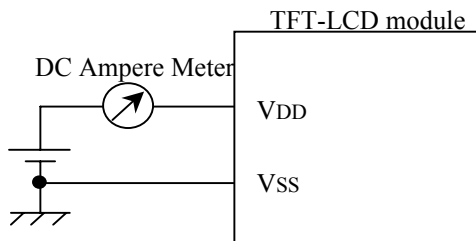

- 2) Current fuse is built in a module. Current capacity of power supply for VDD should be larger than 4A, so that the fuse can be opened at the trouble of electrical circuit of module.

3.2 Back Light

ITEM		SYMBOL	Min.	Typ.	Max.	UNIT	NOTE
Input Voltage		V _{in}	330	370	410	V	
IC Power supply		V _{ic}	10.8	12.0	13.2	V	
ON/OFF Control Voltage	ON	ON/OFF	2.7	3.0	3.3	V	
	OFF		0	-	0.4		
Analog Dimming Input Voltage	Min. Brightness	V _{adim}	1.0	1.2	1.4	V	
	Max. Brightness		-0.2	0	0.2		
PWM Signal	Low	V _{pwm}	-	-	0.8	V	
	High		2.0	-	-		
PWM Frequency		-	200	240	252	Hz	Specific assurance
			60	-	200	Hz	Working assurance 4)
On-Duty Range for Burst-Dimming		On-Duty	27	-	95	%	3)
Output Current		I _L	(113)	126	(138)	mArms	
Output Voltage	T _a =25°C	V _L	(1150)	1250	(1325)	V _{rms}	
	T _a =0°C		(1245)	1350	(1430)		
Output frequency		f	59.6	60.0	60.4	kHz	
Status Output	Normal	Fail	-	0	0.8	V	Keep low while enable is on and off as long as system is normal.
	Failed stop		Open Collector			V	
EEFL Life Time		-	50,000	60,000	-	hours	2)

- Note 1) This characteristics should be applied putting on the lamp about 60 minutes later with ambient temperature. (T_a = 25 °C ± 2 °C)
- 2) Life time of a lamp is defined. The life is determined as the time at which brightness of the lamp is 50 % compared to that of initial value at that typical lamp current on condition of continuous operating at 25 ± 2 °C.
- 3) In case ambient temperature less than 0 degree , on duty range for burst dimming should be over 40%.
- 4) Assure the working of MD without image quality, for example flicker.

4. BLOCK DIAGRAM

(1) TFT-LCD module

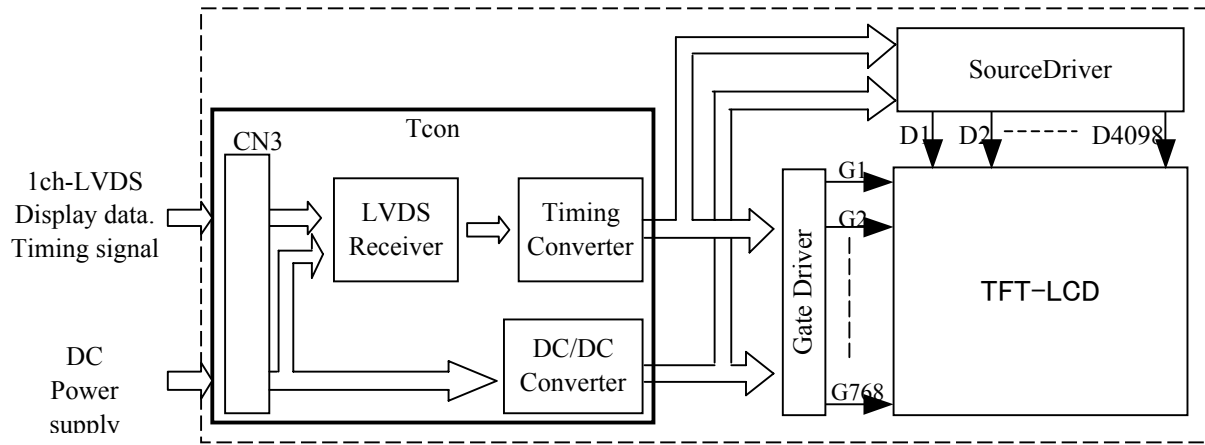

(2) Back light unit

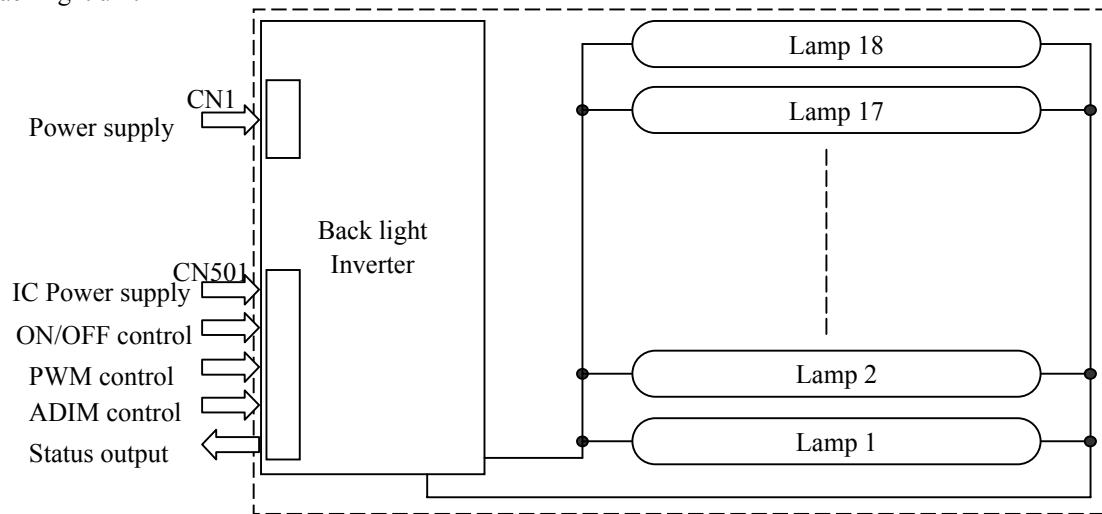

5. INTERFACE PIN ASSIGNMENT

5.1 TFT-LCD Module

CN3:JAE FI-X30SSL-HF

(Matching connector : JAE FI-X30C2L)

Pin No.	SYMBOL	Description	Note
1	VDD	Power Supply (typ.+12V)	1)
2	VDD		
3	VDD		
4	VDD		
5	VSS	GND(0V)	2)
6	VSS		
7	VSS		
8	VSS	Internally Connected, Keep Open	
9	IC		
10	IC	GND(0V)	
11	VSS		
12	Rx0-	Pixel Data	3)
13	Rx0+		
14	VSS	GND(0V)	2)
15	Rx1-	Pixel Data	3)
16	Rx1+		
17	VSS	GND(0V)	2)
18	Rx2-	Pixel Data	3)
19	Rx2+		
20	VSS	GND(0V)	2)
21	CLK-	Pixel Clock	3)
22	CLK+		
23	VSS	GND(0V)	2)
24	Rx3-	Pixel Data	3)
25	Rx3+		
26	VSS	GND(0V)	2)
27	IC	Internally Connected, Keep Open	
28	IC		
29	IC		
30	IC		

- Notes
- 1) All VDD pins shall be connected to +12.0V(Typ.).
 - 2) All VSS pins shall be grounded. Metal bezel is internally connected to VSS.
 - 3) Rx n+ and Rx n- (n=0,1,2,3) should be wired by twist-pairs or side-by-side FPC patterns, respectively.

5.2 Back Light Unit

CN1:JST B3P(5-3,4)-VH

(Matching connecor : JST PHR-5)

PIN No.	SYMBOL	DESCRIPTION	NOTE
1	V-	GND (0V)	1)
2	V-	GND (0V)	
3	-	No Pin	
4	-		
5	V+	Power supply (typ.370V)	

CN501:JST B14B-PH-K-S

(Matching connecor : JST PHR-14)

PIN No.	SYMBOL	DESCRIPTION	NOTE
1	VIC	Power supply of inverter IC(+ 12V)	
2	ON/OFF	High : LAMP ON Low : LAMP OFF	
3	ADIM	Analog Dimming	
4	FAIL	Fail signal	
5	PWM	PWM signal	
6	GND	GND	
7	NC	No connection	
8	NC		
9	NC		
10	NC		
11	NC		
12	NC		
13	NC		
14	NC		

5.3 Block Diagram of Interface

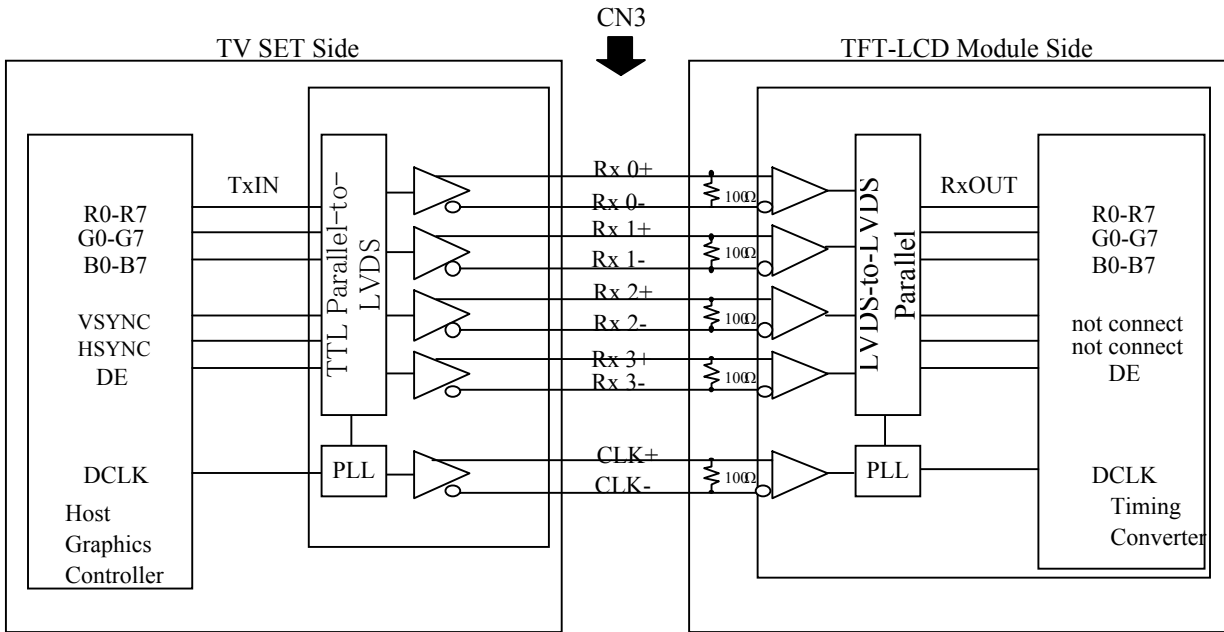

R0~R7 : Pixel R Data (7; MSB, 0; LSB)
 G0~G7 : Pixel G Data (7; MSB, 0; LSB)
 B0~B7 : Pixel B Data (7; MSB, 0; LSB)
 DE : Data Enable

- Note 1) The system must have the transmitter to drive the module.
 2) LVDS cable impedance shall be 50 ohms per signal line or about 100 ohms per twist-pair line when it is used differentially.

5. 4 LVDS Interface

	SIGNAL	TRANSMITTER THC63LVDM83A		INTERFACE CONNECTOR		RECEIVER		TFT CONTROL		
		PIN	INPUT	TV Set	TFT-LCD	PIN	OUTPUT	INPUT		
24bit	R2	51	Tx IN0	TA OUT0+	Rx 0+	27	Rx OUT0	R2		
	R3	52	Tx IN1			29	Rx OUT1	R3		
	R4	54	Tx IN2			30	Rx OUT2	R4		
	R5	55	Tx IN3			32	Rx OUT3	R5		
	R6	56	Tx IN4			33	Rx OUT4	R6		
	R7	3	Tx IN6			TA OUT0-	Rx 0-	35	Rx OUT6	R7
	G2	4	Tx IN7			37	Rx OUT7	G2		
	G3	6	Tx IN8	TA OUT1+	Rx 1+	38	Rx OUT8	G3		
	G4	7	Tx IN9			39	Rx OUT9	G4		
	G5	11	Tx IN12			43	Rx OUT12	G5		
	G6	12	Tx IN13			45	Rx OUT13	G6		
	G7	14	Tx IN14			46	Rx OUT14	G7		
	B2	15	Tx IN15			TA OUT1-	Rx 1-	47	Rx OUT15	B2
	B3	19	Tx IN18			51	Rx OUT18	B3		
	B4	20	Tx IN19	TA OUT2+	Rx 2+	53	Rx OUT19	B4		
	B5	22	Tx IN20			54	Rx OUT20	B5		
	B6	23	Tx IN21			55	Rx OUT21	B6		
	B7	24	Tx IN22			1	Rx OUT22	B7		
	HSYNC	27	Tx IN24			3	Rx OUT24	not connect		
	VSYNC	28	Tx IN25			TA OUT2-	Rx 2-	5	Rx OUT25	not connect
	DE	30	Tx IN26			6	Rx OUT26	DE		
	R0	50	Tx IN27	TA OUT3+	Rx 3+	7	Rx OUT27	R0		
	R1	2	Tx IN5			34	Rx OUT5	R1		
	G0	8	Tx IN10			41	Rx OUT10	G0		
	G1	10	Tx IN11			42	Rx OUT11	G1		
B0	16	Tx IN16	49			Rx OUT16	B0			
B1	18	Tx IN17	TA OUT3-			Rx 3-	50	Rx OUT17	B1	
RSVD 1)	25	Tx IN23	2			Rx OUT23	not connect			
	DCLK	31	TxCLK IN	TxCLK OUT+ TxCLK OUT-	RxCLK IN+ RxCLK IN-	26	RxCLK OUT	DCLK		

R0~R7 : Pixel R Data (7; MSB, 0; LSB)
 G0~G7 : Pixel G Data (7; MSB, 0; LSB)
 B0~B7 : Pixel B Data (7; MSB, 0; LSB)
 DE : Data Enable

Note 1) RSVD(reserved)pins on the transmitter shall be tied to"H"or"L".

5. 5 Correspondence Between Input Data and Display Image

Display data of adjacent one pixel is latched during one cycle of DCLK.

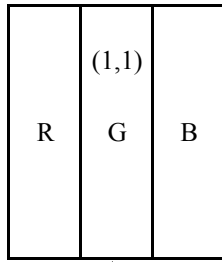

Pixel : R0 - R7 : R data
 G0 - G7 : G data
 B0 - B7 : B data

1, 1	1, 2	1, 3	-----	1, 1366
2, 1	2, 2	2, 3	-----	2, 1366
3, 1	3, 2	3, 3	-----	3, 1366
⋮	⋮	⋮		⋮
768, 1	768, 2	768, 3		768, 1366

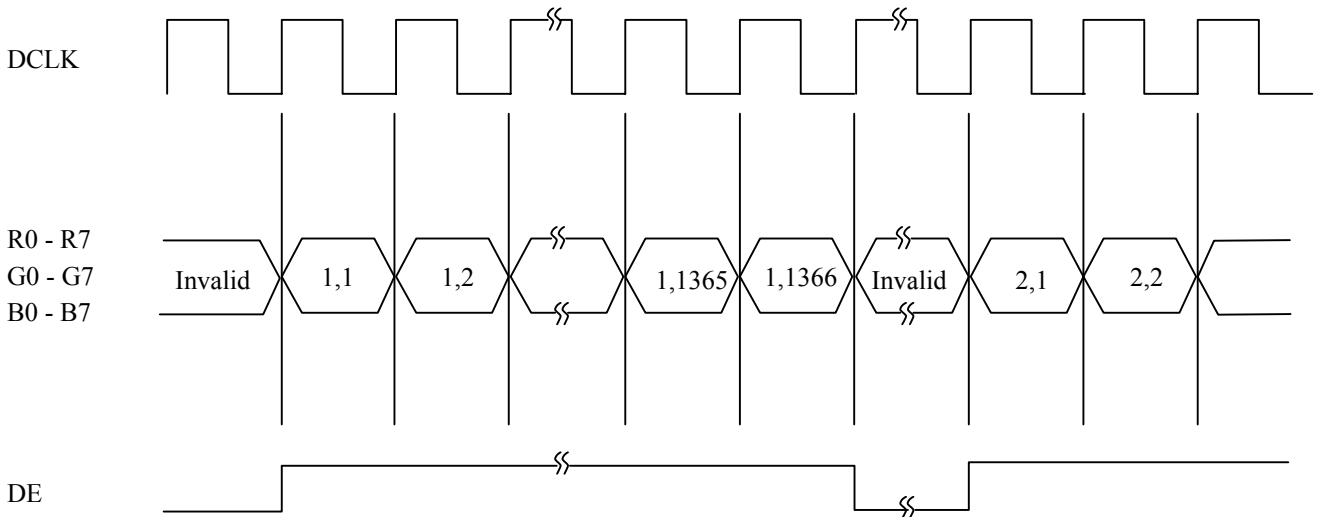

5. 6 Relationship Between Display Colors And Input Signals

Input		Red Data								Green Data								Blue Data							
		R7	R6	R5	R4	R3	R2	R1	R0	G7	G6	G5	G4	G3	G2	G1	G0	B7	B6	B5	B4	B3	B2	B1	B0
		MSB				LSB				MSB				LSB				MSB				LSB			
Basic Color	Black	0	0	0	0	0	0	0	0	0	0	0	0	0	0	0	0	0	0	0	0	0	0	0	0
	Red(255)	1	1	1	1	1	1	1	1	0	0	0	0	0	0	0	0	0	0	0	0	0	0	0	0
	Green(255)	0	0	0	0	0	0	0	0	1	1	1	1	1	1	1	1	0	0	0	0	0	0	0	0
	Blue(255)	0	0	0	0	0	0	0	0	0	0	0	0	0	0	0	0	1	1	1	1	1	1	1	1
	Cyan	0	0	0	0	0	0	0	0	1	1	1	1	1	1	1	1	1	1	1	1	1	1	1	1
	Magenta	1	1	1	1	1	1	1	1	0	0	0	0	0	0	0	0	1	1	1	1	1	1	1	1
	Yellow	1	1	1	1	1	1	1	1	1	1	1	1	1	1	1	1	0	0	0	0	0	0	0	0
	White	1	1	1	1	1	1	1	1	1	1	1	1	1	1	1	1	1	1	1	1	1	1	1	1
Red	Black	0	0	0	0	0	0	0	0	0	0	0	0	0	0	0	0	0	0	0	0	0	0	0	0
	Red (1)	0	0	0	0	0	0	0	1	0	0	0	0	0	0	0	0	0	0	0	0	0	0	0	0
	Red (2)	0	0	0	0	0	0	1	0	0	0	0	0	0	0	0	0	0	0	0	0	0	0	0	0
	:	:	:	:	:	:	:	:	:	:	:	:	:	:	:	:	:	:	:	:	:	:	:	:	:
	:	:	:	:	:	:	:	:	:	:	:	:	:	:	:	:	:	:	:	:	:	:	:	:	:
	Red(254)	1	1	1	1	1	1	1	0	0	0	0	0	0	0	0	0	0	0	0	0	0	0	0	0
	Red(255)	1	1	1	1	1	1	1	1	0	0	0	0	0	0	0	0	0	0	0	0	0	0	0	0
Green	Black	0	0	0	0	0	0	0	0	0	0	0	0	0	0	0	0	0	0	0	0	0	0	0	0
	Green (1)	0	0	0	0	0	0	0	0	0	0	0	0	0	0	0	1	0	0	0	0	0	0	0	0
	Green (2)	0	0	0	0	0	0	0	0	0	0	0	0	0	0	1	0	0	0	0	0	0	0	0	0
	:	:	:	:	:	:	:	:	:	:	:	:	:	:	:	:	:	:	:	:	:	:	:	:	:
	:	:	:	:	:	:	:	:	:	:	:	:	:	:	:	:	:	:	:	:	:	:	:	:	:
	Green(254)	0	0	0	0	0	0	0	0	1	1	1	1	1	1	1	0	0	0	0	0	0	0	0	0
	Green(255)	0	0	0	0	0	0	0	0	1	1	1	1	1	1	1	1	0	0	0	0	0	0	0	0
Blue	Black	0	0	0	0	0	0	0	0	0	0	0	0	0	0	0	0	0	0	0	0	0	0	0	0
	Blue (1)	0	0	0	0	0	0	0	0	0	0	0	0	0	0	0	0	0	0	0	0	0	0	0	1
	Blue (2)	0	0	0	0	0	0	0	0	0	0	0	0	0	0	0	0	0	0	0	0	0	0	1	0
	:	:	:	:	:	:	:	:	:	:	:	:	:	:	:	:	:	:	:	:	:	:	:	:	:
	:	:	:	:	:	:	:	:	:	:	:	:	:	:	:	:	:	:	:	:	:	:	:	:	:
	Blue (254)	0	0	0	0	0	0	0	0	0	0	0	0	0	0	0	0	1	1	1	1	1	1	1	0
	Blue (255)	0	0	0	0	0	0	0	0	0	0	0	0	0	0	0	0	1	1	1	1	1	1	1	1

Note 1) Definition of gray scale :
 Color(n) Number in parenthesis indicates gray scale level.
 Larger n correspondsto brighter level.

2) Data : 1 : High, 0 : Low

6. INTERFACE TIMING

6.1 LVDS Receiver Timing

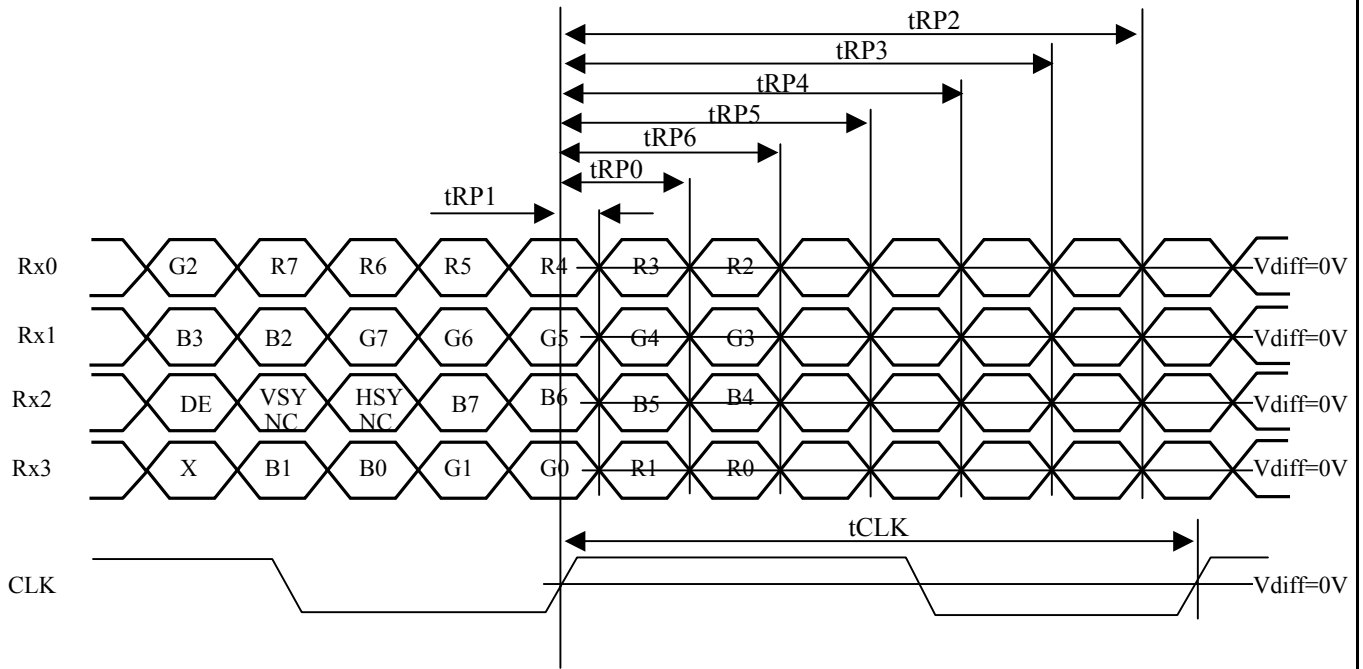

Rx0=(Rx0+)-(Rx0-)

Rx1=(Rx1+)-(Rx1-)

Rx2=(Rx2+)-(Rx2-)

Rx3=(Rx3+)-(Rx3-)

CLK=(CLK+)-(CLK-)

ITEM		SYMBOL	Min.	Typ.	Max.	UNIT	NOTE
CLK	Frequency (at 50 Hz)	DCLK	68	78	87	MHz	=1/tclk
	Frequency (at 60 Hz)		78	85	87	MHz	=1/tclk
	CLK Skew	tSC	- 4.0	0	+ 4.0	ns	
Rx*0 Rx*1 Rx*2 Rx*3	0 data position	tRP0	1/7tCLK - 0.4	1/7tCLK	1/7tCLK + 0.4	ns	
	1st data position	tRP1	- 0.4	0	+ 0.4		
	2nd data position	tRP2	6/7tCLK - 0.4	6/7tCLK	6/7tCLK + 0.4		
	3rd data position	tRP3	5/7tCLK - 0.4	5/7tCLK	5/7tCLK + 0.4		
	4th data position	tRP4	4/7tCLK - 0.4	4/7tCLK	4/7tCLK + 0.4		
	5th data position	tRP5	3/7tCLK - 0.4	3/7tCLK	3/7tCLK + 0.4		
	6th data position	tRP6	2/7tCLK - 0.4	2/7tCLK	2/7tCLK + 0.4		

6.2 Synchronization Signal Timing

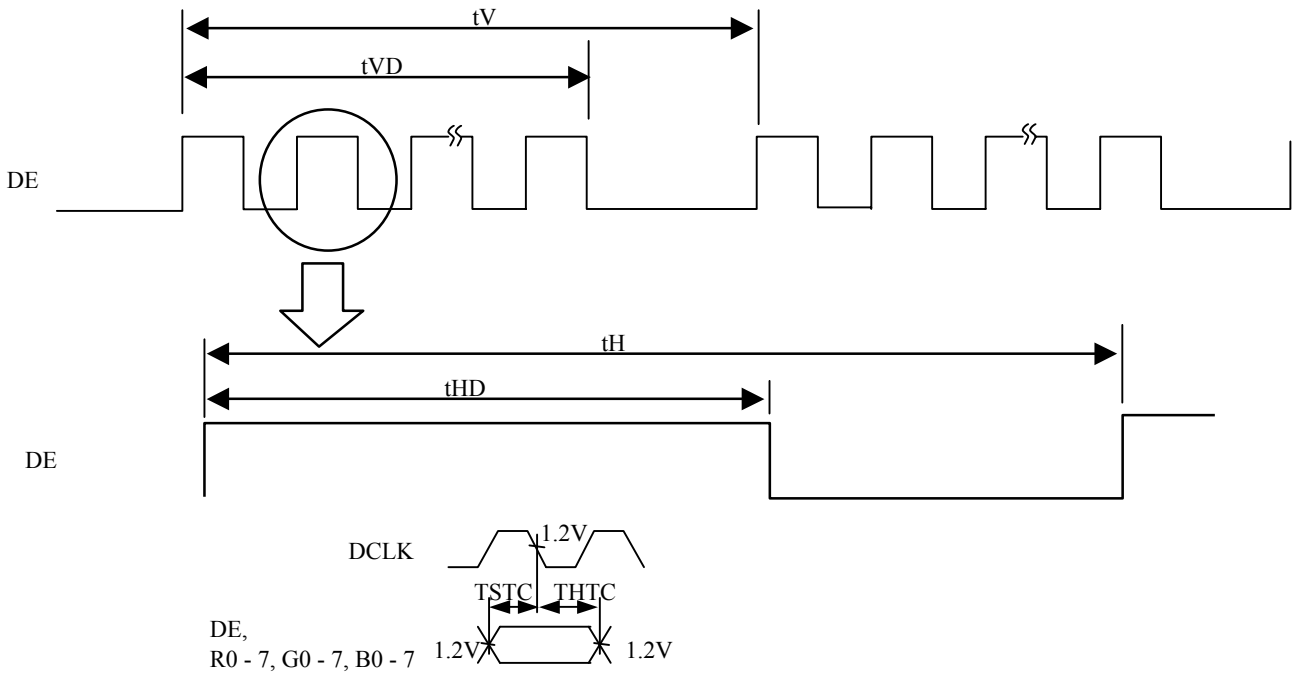

- Note 1) Reference level for each timing signal is 1.2 V unless it is stated on the chart, high level voltage(VIH) and low level voltage(VIL) are defined as follows:
 $V_{IH} \geq 2.0\text{ V}$ $V_{IL} \leq 0.8\text{ V}$
- 2) The timing of DCLK to other signals conforms to the specifications of LVDS transmitter.

I) 50Hz

2pxl/clock

ITEM	SYMBOL	Min.	Typ.	Max.	UNIT	NOTE
DE	Vertical Frequency	fV	48	50	52	Hz
	Vertical Period	tV	773	860	1000	tH
	Vertical Valid	tVD	768			tH
	Horizontal Frequency	fH	-	43	-	kHz
	Horizontal Period	tH	1400	1814	2000	tCLK
	Horizontal Valid	tHD	1366			tCLK

II) 60Hz

2pxl/clock

ITEM	SYMBOL	Min.	Typ.	Max.	UNIT	NOTE
DE	Vertical Frequency	fV	58	60	62	Hz
	Vertical Period	tV	773	773	1000	tH
	Vertical Valid	tVD	768			tH
	Horizontal Frequency	fH	-	46.4	-	kHz
	Horizontal Period	tH	1400	1833	2000	tCLK
	Horizontal Valid	tHD	1366			tCLK

6.3 Timing Between Interface Signals Power Supply

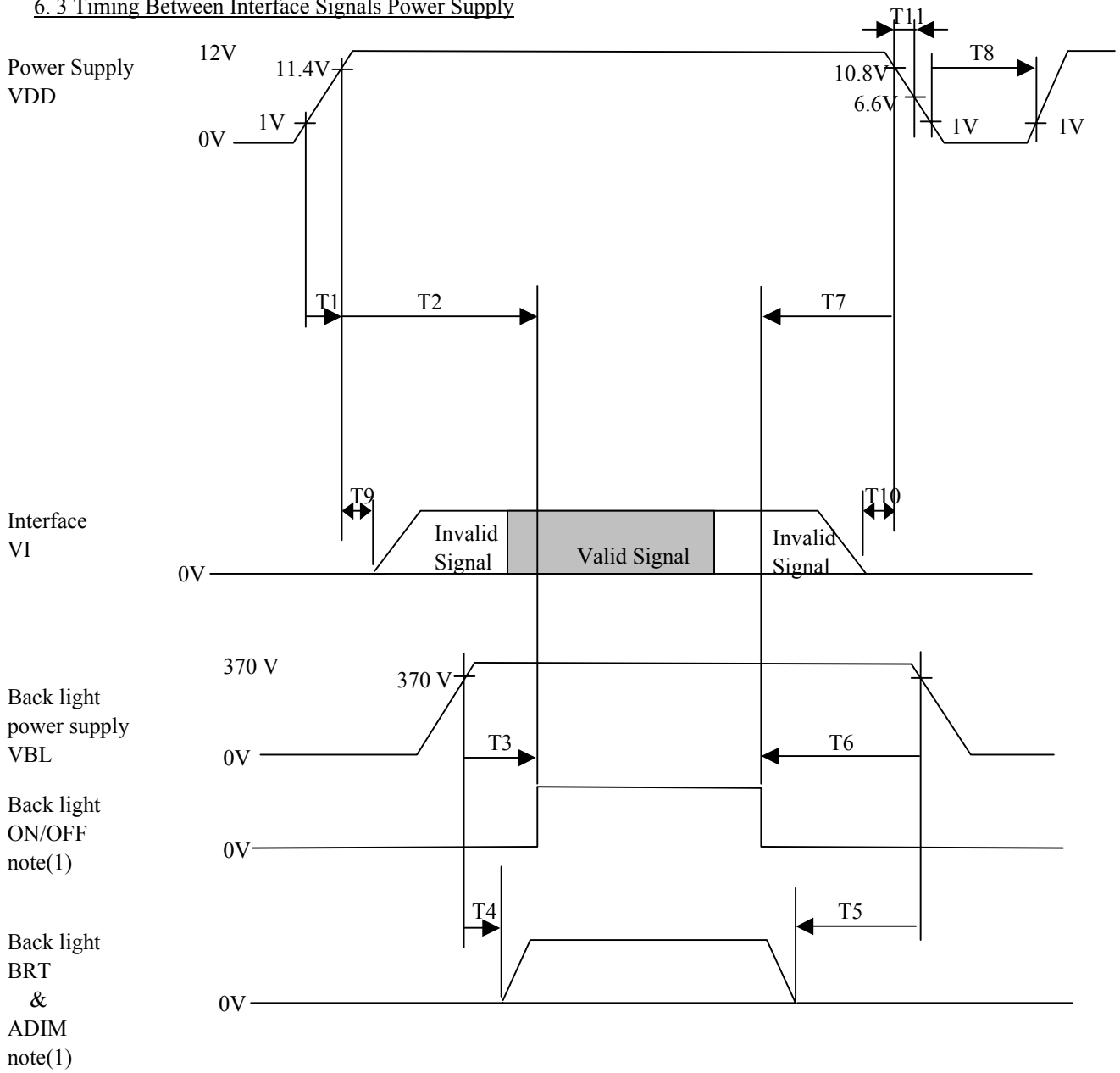

$0 \leq T1 \leq 10$	$0 < T5$	$10 \leq T9$	$10 < T11$
$350 \leq T2$	$100 < T6$	$0 \leq T10$	
$0 \leq T3$	$0 \leq T7$		
$1 \leq T4$	$350 \leq T8$		

Unit : ms

7. DIMENSIONAL OUT LINE

(1) FRONT VIEW

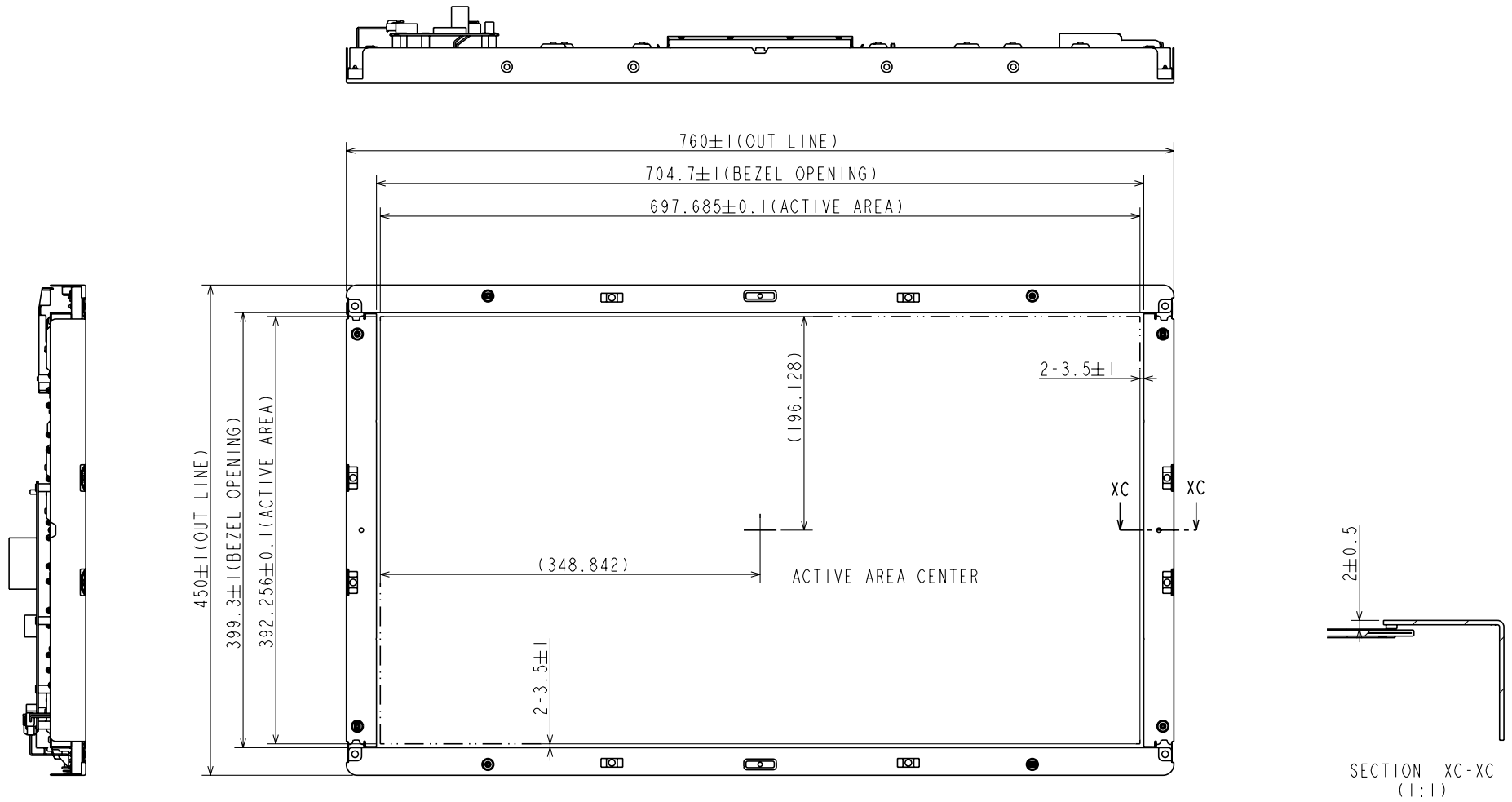

Note 1) The dimension in a parenthesis is a reference value.
 2) Unspecified tolerance to be ± 0.8

IPS Alpha Technology, Ltd.	Date	Nov.26,2007	Sh. No.	IPS4PS 2610 AX080A014B-1	Page	10-1/2
----------------------------	------	-------------	---------	--------------------------	------	--------

(2)BACK VIEW

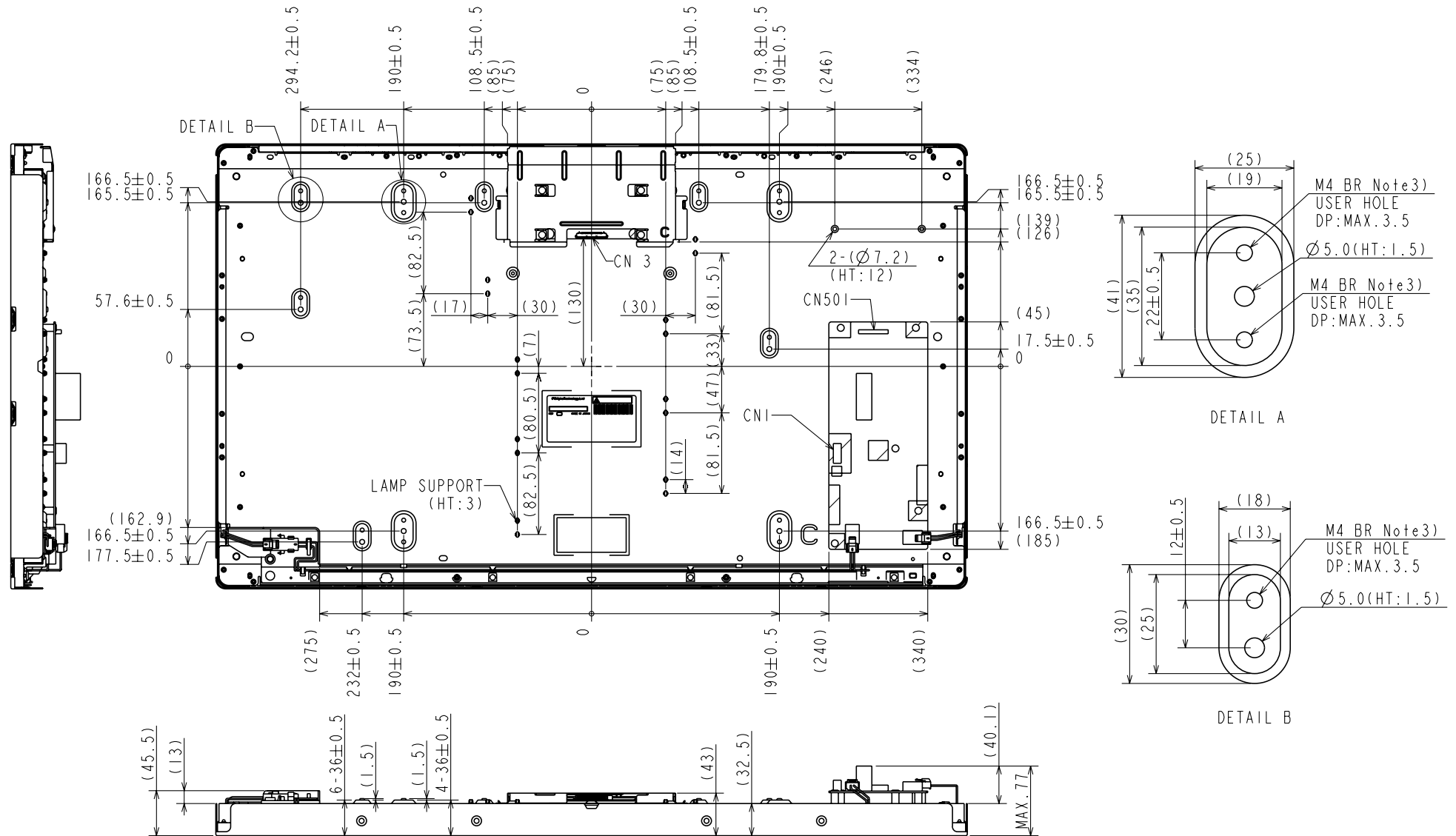

- Note 1) The dimension in a parenthesis is a reference value.
 2) Unspecified tolerance to be ±0.8
 3) Torque MAX. 1.47N·m(15kgf·cm)

IPS Alpha Technology, Ltd.	Date	Nov.26,2007	Sh. No.	IPS4PS 2610 AX080A014B-1	Page	10-2/2
----------------------------	------	-------------	---------	--------------------------	------	--------

8. DESIGNATION OF LOT MARK

8.1 LOT MARK

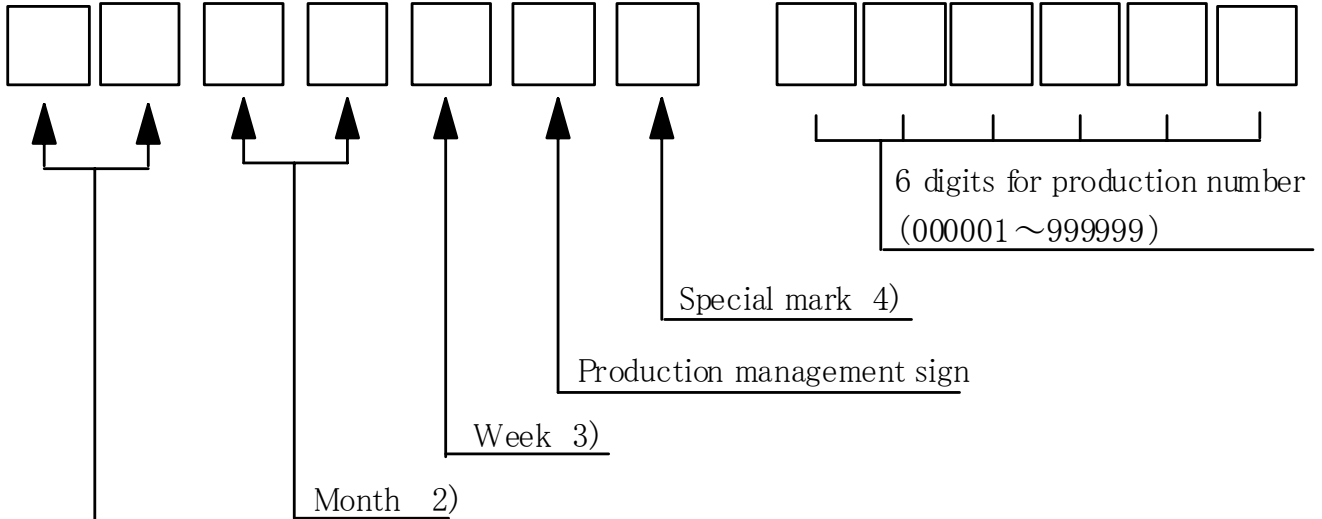

Notes

Year 1)

Year	Mark
2007	07
2008	08
2009	09

Month	Mark	Month	Mark
1	01	7	07
2	02	8	08
3	03	9	09
4	04	10	10
5	05	11	11
6	06	12	12

Week(Day)	Mark
1 ~ 7	1
8 ~ 14	2
15 ~ 21	3
22 ~ 28	4
29 ~ 31	5

4) "A":Liquid crystal A, "B":Liquid crystal B

8.2 Revision (REV.) control

REV. is the column for manufacturing convenience. A-Z except I and O may be written on this column.

8.3 Location of lot mark

Lot mark is printed on a label. The label is on the metallic bezel as shown in 7. External Dimensional. The style of character will be changed without notice.



8.4 Record of the revision described on the label

Revision	Specification
A	Initial

9. COSMETIC SPECIFICATIONS

9.1 Condition for cosmetic inspection

(1) Viewing zone

- a) The figure shows the correspondence between eyes (of inspector) and TFT-LCD module.
 $\theta \leq 45^\circ$: when non-operating inspection
 $\theta \leq 5^\circ$: when operating inspection
- b) Inspection should be executed only from front side and only A-zone.
 Cosmetic of B-zone and C-zone are ignore.
 (refer to 9.2 Definition of zone)

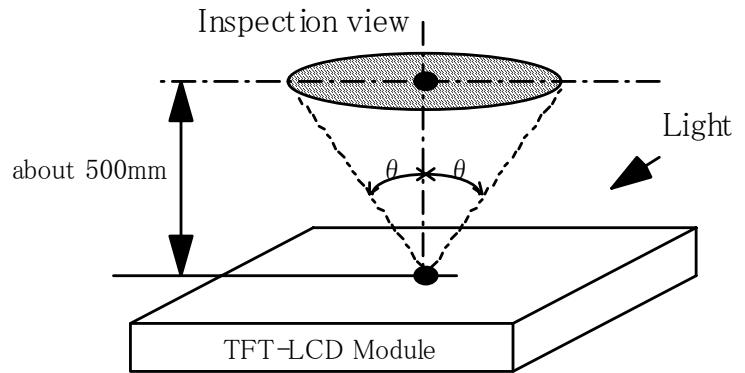

(2) Environmental

- a) Temperature : 25 degrees
- b) Ambient light : about 700 lx and non-directive when operating inspection.
 : about 1000 lx and non-directive when non-operating inspection.
- c) Back-light : when non-operating inspection, back-light should be off .

9.2 Definition of zone

- A-zone : Display area (pixel area)
- B-zone : Area between A-zone and C-zone
- C-zone : Metallic bezel area

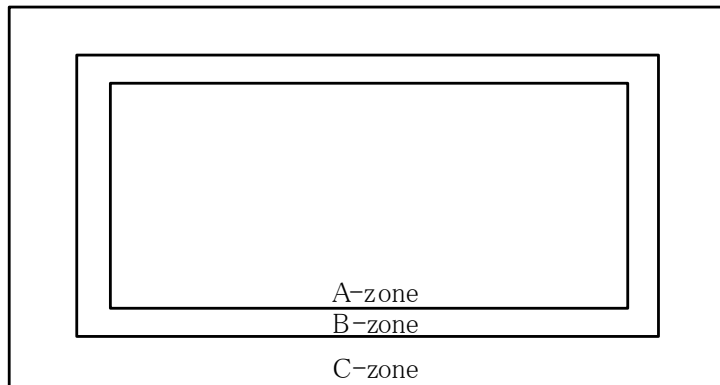

9.3 COSMETIC SPECIFICATIONS

When displaying conditions are not stable (ex. at turn on or off), the following specifications are not applied.

	No	ITEM		Max. acceptable number		Unit	Note	
				Bright defect	Low bright defect			
Operating inspection	1	Dot defect	Sparkle mode	1-dot	0	4	pcs	1),2),4)
				2-dots	0		Units	1),2),5)
				3-dots	0			
				Density	0			
				Total	4		pcs	1),2)
			Black mode	1-dot	7		pcs	1),3),4)
				2-dots	0		Units	1),3),5)
				3-dots	0			
				Density	3			
				Total	7		pcs	1),3)
	Total	9		pcs	1)			
	2	Line defect			Serious one is not allowed		-	-
	3	Uneven brightness						
	4	Stain inclusion (Line shape) W : width (mm) L : length (mm)	W \leq 0.02	L : Ignore	Ignore		pcs	7)
			W \leq 0.04	L \leq 4.0	8			
L > 4.0				0				
W \leq 0.08			L \leq 2.0	8				
			L > 2.0	0				
W > 0.08	-	(See dot shape)						
5	Stain inclusion (Dot shape) D : ave. dia (mm)	D \leq 0.22		Ignore		pcs	7)	
		D \leq 0.5		8				
		D > 0.5		0				
6	Scratch on polarizer (Line shape) W : width (mm) L : length (mm)	W \leq 0.02	L : Ignore	Ignore		pcs	8)	
		W \leq 0.08	L \leq 20	10				
			L > 20	0				
		W > 0.08	-	0				
7	Scratch on polarizer (Dot shape) D : ave. dia (mm)	D \leq 0.2		Ignore		pcs	8)	
		D \leq 0.6		10				
		D > 0.6		0				

	No	ITEM		Max. acceptable number	Unit	Note
				A-zone		
	8	Bubbles, peeling in polarizer [D : ave. dia (mm)]	D ≤ 0.2	Ignore	pcs	8)
			D ≤ 0.5	10		
			D > 0.5	0		
	9	Wrinkles on polarizer		Serious one is not allowed.	-	-

Note 1) Dot defect : defect area > 1/2 dot

2) Sparkle mode :

bright defect G > 24.3%

R > 24.3%

B > 24.3%

low bright defect 24.3% ≥ G > 4.1%

24.3% ≥ R > 7.8%

24.3% ≥ B > 18.0%

3) Black mode : brightness of dot is less than 70% at white. (visible to eye)

4) 1 dot : defect dot is isolated, not attached to other defect dot.

5) N dots : N defect dots are consecutive. (N means the number of defects dots)

6) Density : number of defect dots inside φ 20mm

7) Those stains which can be wiped out easily are acceptable.

8) Polarizer area inside of B-zone is not applied.

9) No major (serious) defects when viewed in gray scale mode.

10. PRECAUTION

Please pay attention to the followings when a TFT module with a back-light unit is used, handled and mounted.

10.1 Precaution to handling and mounting

- (1) Applying strong force to a part of the module may cause partial deformation of frame or mold, and cause damage to the display.
- (2) The module should gently and firmly be held by both hands. Never hold by just one hand in order to avoid any internal damage. Never drop or hit the module.
- (3) The module should be installed with mounting holes of a module.
- (4) Uneven force such as twisted stress should not be applied to a module when a module is mounted on the cover case. The cover case must have sufficient strength so that external force can not be transmitted directly to a module.
- (5) It is recommended to leave a space between a module and a holding board of a module so that partial force is not applied to a module.

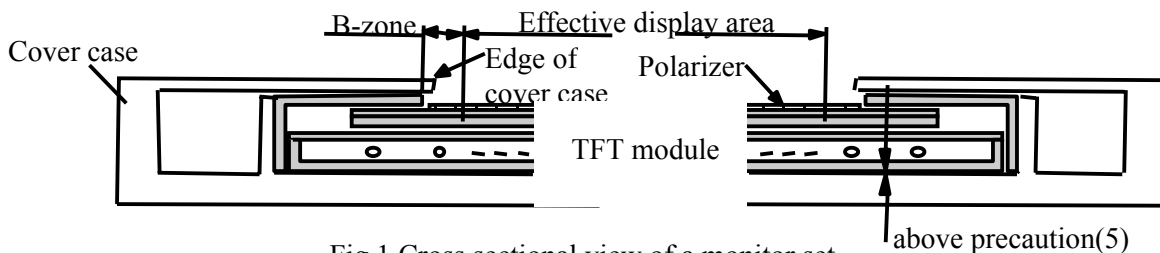

Fig.1 Cross sectional view of a monitor set

- (6) The edge of a cover case should be located inside more than 1mm from the edge of a module front frame.
- (7) A transparent protective plate should be added on the display area of a module in order to protect a polarizer and TFT cell. The transparent protective plate should have sufficient strength so that the plate can not touch a module by external force.
- (8) Materials included acetic acid and choline should not be used for a cover case as well as other parts and boards near a module. Acetic acid attacks a polarizer. Choline attacks electric circuits due to electro-chemical reaction.
- (9) The polarizer on a TFT cell should carefully be handled due to its softness, and should not be touched, pushed or rubbed with glass, tweezers or anything harder than HB pencil lead. The surface of a polarizer should not be touched and rubbed with bare hand, greasy clothes or dusty clothes.
- (10) The surface of a polarizer should be gently wiped with absorbent cotton, chamois or other soft materials slightly contained petroleum benzene when the surface becomes dirty. Normal-hexane as cleaning chemicals is recommended in order to clean adhesives which fix front/rear polarizers on a TFT cell. Other cleaning chemicals such as acetone, toluen and alcohol should not be used to clean adhesives because they cause chemical damage to a polarizer.
- (11) Saliva or water drops should be immediately wiped off. Otherwise, the portion of a polarizer may be deformed and its color may be faded.
- (12) The module should not be opened or modified. It may cause not to operate properly.

- (13) Metallic bezel of a module should not be handled with bare hand or dirty gloves. Otherwise, color of a metallic frame may become dirty during its storage. It is recommended to use clean soft gloves and clean finger stalls when a module is handled at incoming inspection process and production (assembly) process.
- (14) Lamp(EEFL) cables should not be pulled and held.

10.2 Precaution to operation

- (1) The ambient temperature near the operated module should be satisfied with the absolute maximum ratings. Unless it meets the specifications, sufficient cooling system should be adopted to system.
- (2) The spike noise causes the mis-operation of a module. The level of spike noise should be as follows:
 $-200\text{mV} \leq \text{over- and under- shoot of VDD} \leq +200\text{mV}$
 VDD including over- and under- shoot should be satisfied with the absolute maximum ratings.
- (3) Optical response time, luminance and chromaticity depend on the temperature of a TFT module. Response time and saturation time of EEFL luminance become longer at lower temperature operation.
- (4) Sudden temperature change may cause dew on and/or in the a module. Dew males damage to a polarizer and/or electrical contacting portion. Dew causes fading of displayed quality.
- (5) Fixed patterns displayed on a module for a long time may cause after-image. It will be recovered soon.
- (6) A module has high frequency circuits. Sufficient suppression to electromagnetic interference should be done by system manufacturers. Grounding and shielding methods may be effective to minimize the interference.
- (7) Noise may be heard when a back-light is operated. If necessary, sufficient suppression should be done by system manufacturers.
- (8) The module should not be connected or removed while a main system works.
- (9) Inserting or pulling I/F connectors causes any trouble when power supply and signal dates are on-state. I/F connectors should be inserted and pulled after power supply and signal dates are turned off.

10.3 Electrostatic discharge control

- (1) Since a module consists of a TFT cell and electronic circuits with CMOS-ICs, which are very weak to electrostatic discharge, persons who are handling a module should be grounded through adequate methods such as a list band. I/F connector pins should not be touched directly with bare hands.
- (2) Protection film for a polarizer on a module should be slowly peeled off so that the electrostatic charge can be minimized.

10.4 Precaution to strong light exposure

- (1) A module should not be exposed under strong light. Otherwise, characteristics of a polarizer and color filter in a module may be degraded.

10.5 Precaution to storage

When modules for replacement are stored for a long time, following precautions should be taken care of:

- (1) Modules should be stored in a dark place. It is prohibited to apply sunlight or fluorescent light during storage. Modules should be stored at 0 to 35-C at normal humidity (60%RH or less).
- (2) The surface of polarizers should not come in contact with any other object. It is recommended that modules should be stored in the Hitachi's shipping box.

10.6 Precaution to handling protection film

- (1) The protection film for polarizers should be peeled off slowly and carefully by persons who are electrically grounded with adequate methods such as a list band. Besides, ionized air should be blown over during peeling action. Dusts on a polarizer should be blown off by an ionized nitrogen gun and so on.
- (2) The protection film should be peeling off without rubbing it to the polarizer. Because, if the film is rubbed together with the polarizer, since the film is attached to the polarizer with a small amount of adhesive, the adhesive may remain on a polarizer.
- (3) The module with protection film should be stored on the conditions explained in 10.5 (1). However, in case that the storage time is too long, adhesive may remain on a polarizer even after a protection film is peeled off. Besides, in case that a module is stored at higher temperature and/or higher humidity, adhesive may remain on a polarizer. The remained adhesive may cause non-uniformity of display image.
- (4) The adhesive can be removed easily with Normal-Hexane. The remained adhesive or its vestige on the polarizer should be wiped off with absorbent cotton or other soft materials such as chamois slightly contained Normal-Hexane.

10.7 Safety

- (1) Since a TFT cell and lamps are made of glass, handling to the broken module should be taken care sufficiently in order not to be injured. Hands touched liquid crystal from a broken cell should be washed sufficiently.
- (2) The module should not be taken apart during operation so that back-light drives by high voltage.

10.8 Environmental protection

- (1) The TFT module contains cold cathode fluorescent lamps. Please follow local ordinance or regulations for its disposal.
- (2) Flexible printed circuits and printed circuits board used in a module contain small amount of lead. Please follow local ordinance or regulations for its disposal.

10.9 Use restrictions and limitations

- (1) This product is not authorized for use in life support devices or systems, military applications or other applications which pose a significant risk of personal injury.
- (2) In no event shall IPS Alpha Technology, Ltd., be liable for any incidental, indirect or consequential damages in connection with the installation or use of this product, even if informed of the possibility thereof in advance. These limitations apply to all causes of action in the aggregate, including without limitation breach of contract, breach of warranty, negligence, strict liability, misrepresentation and other torts.

10.10 Others

- (1) Electrical components which may not affect electrical performance are subjective to change without notice because of their availability.

11.Packing

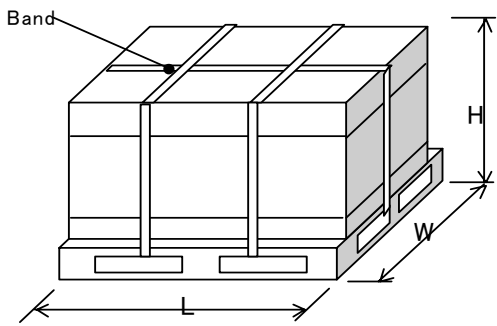
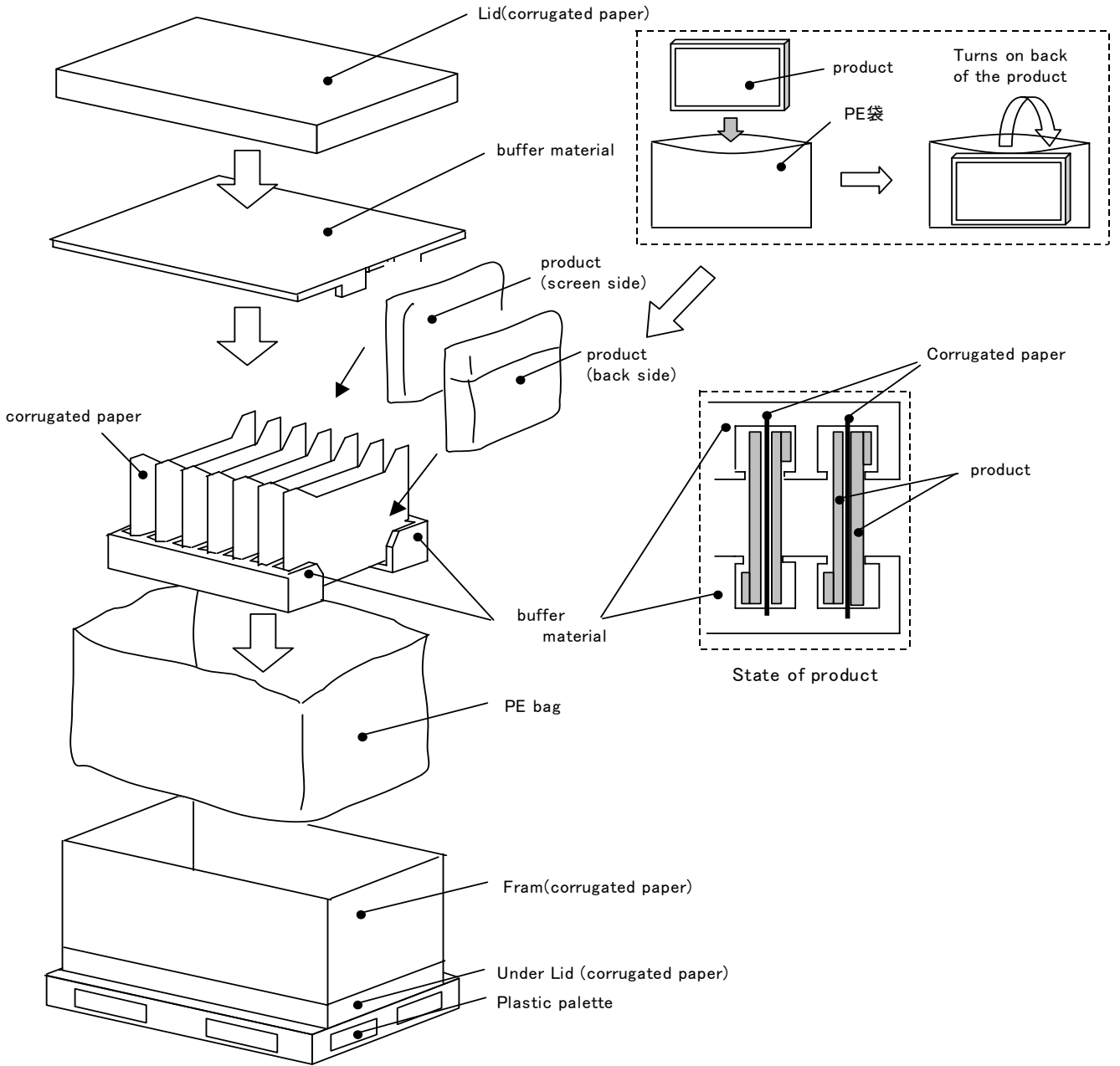

(14products/palette)

Size : 1210(L)×1000(W)×675(H) mm

Weight : 127kg

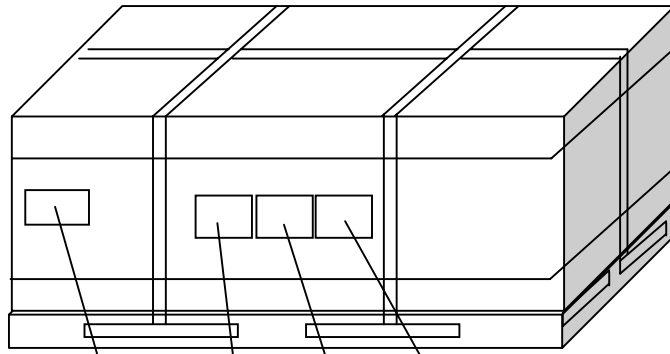

identification tag global code※ ※Left and right are reversed occasionally.
 address※ wrapping indication※

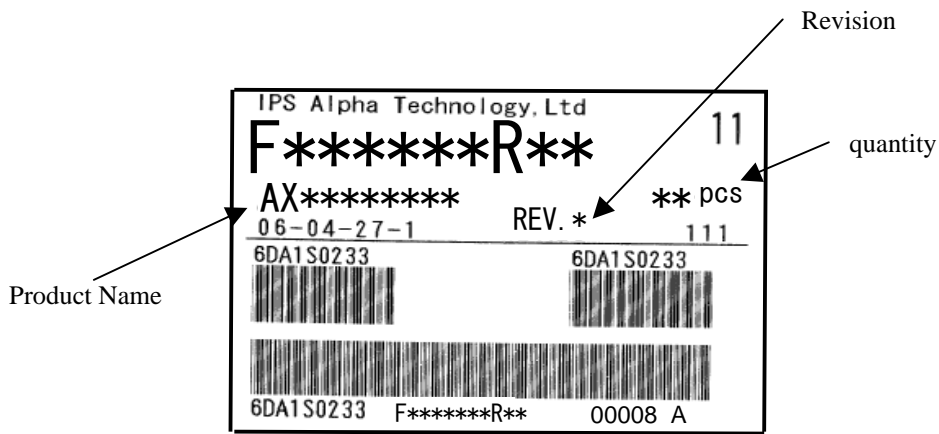

production slip (ex.) label size (102 × 70)



address (ex.)



wrapping indication (ex.)

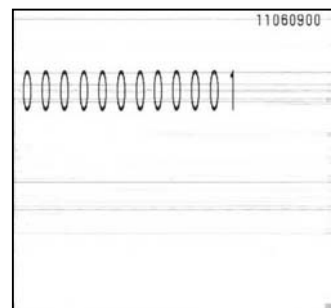

global code (ex.)

12. Reliability test

No.	Item	condition	Quantity	Period	
				determination	end
1	Low Temperature / Operating	Ta=0°C	3	500h	1000h
2	High Temperature / Operating	Ta=45°C	3	500h	1000h
3	High Temperature High Humidity / Operating	45°C 95%RH	3	500h	1000h
4	Low Temperature / Strage	Ta=-30°C	3	500h	1000h
5	High Temperature / Strage	Ta=70°C	3	500h	1000h
6	High Temperature High Humidity / Strage	45°C 95%RH	3	500h	1000h
7	Heat shock	-25/70°C 30min./30min.	3	100cy.	200cy.
8	Heat shock test for solder	-35/85°C 30min./30min.	3	200cy.	500cy.

Result Evaluation

display function should be kept.

13.Condition of Withstand Voltage and Insulation Resistance Test

- AC3000V (+100V,-0V),60Hz 3s(+1s,-0s) Maximum Detection Current 3mA Between CN1 and FG.
- 150MΩ min , at DC500V Between CN1 and FG.