

Tentative

## IPS Alpha Technology, Ltd.

## TECHNICAL DATA

AX080B058GCONTENTS

No.	Item	Sheet No.			Page
-	COVER	ATD1403	2601	AX080B058G	1-1/1
-	RECORD OF REVISION	ATD1403	2602	AX080B058G	2-1/1
-	DESCRIPTION	ATD1403	2603	AX080B058G	3-1/1
1	ABSOLUTE MAXIMUM RATINGS	ATD1403	2604	AX080B058G	4-1/1
2	INITIAL OPTICAL CHARACTERISTICS	ATD1403	2605	AX080B058G	5-1/2~2/2
3	ELECTRICAL CHARACTERISTICS	ATD1403	2606	AX080B058G	6-1/1
4	BLOCK DIAGRAM	ATD1403	2607	AX080B058G	7-1/1
5	INTERFACE PIN ASSIGNMENT	ATD1403	2608	AX080B058G	8-1/6~6/6
6	INTERFACE TIMING	ATD1403	2609	AX080B058G	9-1/3~3/3
7	DIMENSIONAL OUTLINE	ATD1403	2610	AX080B058G	10-1/3~3/3
8					
9					
10					
11					
12					

RECORD OF REVISION

Date	The upper section : Before revision The lower section : After revision		Summary
	Sheet No.	Page	

DESCRIPTION

The following specifications are applied to the following TFT module.

Note : Inverter for back light unit is built in this module.

Product Name : AX080B058G

General Specifications

Effective Display Area	: (H)697.685×(V)392.256	(mm)
Number of Pixels	: (H)1,366×(V)768	(pixels)
Pixel Pitch	: (H)0.51075×(V)0.51075	(mm)
Color Pixel Arrangement	: R+G+B Vertical Stripe	
Display Mode	: Transmissive Mode Normally Black Mode	
Top Polarizer Type	: Semi-Glare	
Number of Colors	: 16,777,216	(colors)
Viewing Angle Range	: Wide Version (Horizontal & Vertical : 170° at $\varphi=0^\circ, 90^\circ, 180^\circ, 270^\circ$ , $CR \geq 10$ )	
Input Signal	: 1-channel LVDS (LVDS:Low Voltage Differential Signaling)	
Back Light	: 8pcs. of CCFL	
External Dimensions	: (H)760.0 x (V)450.0 x (t)48.0Max	(mm)
Weight	: 6,100	(g)

## 1. ABSOLUTE MAXIMUM RATINGS

### 1.1 Environmental Absolute Maximum Ratings

ITEM	Operating		Storage		Unit	Note
	Min.	Max.	Min.	Max.		
Temperature	0	50	-20	60	°C	1),5)
Humidity	2)		2)		%RH	1)
Vibration	-	4.9(0.5G)	-	TBD	m/s <sup>2</sup>	3)
Shock	-	29.4(3G)	-	TBD	m/s <sup>2</sup>	4)
Corrosive Gas	Not Acceptable		Not Acceptable		-	

Note 1) Temperature and Humidity should be applied to the glass surface of a TFT module, not to the system installed with a module.

The temperature at the center of rear surface should be less than 70°C on the condition of operating. The brightness of a CCFL tends to drop at low temperature. Besides, the life-time becomes shorter at low temperature.

2)  $T_a \leq 40^\circ\text{C}$  ······Relative humidity should be less than 85%RH max. Dew is prohibited.

$T_a > 40^\circ\text{C}$  ······Relative humidity should be lower than the moisture of the 85%RH at 40°C.

3) Frequency of the vibration is between 15Hz and 100Hz. (Remove the resonance point)

4) Pulse width of the shock is 10 ms.

5) Long operation under low temperature may cause some portion of display area to be reddish for several minutes after turning on the product.

However, it does not affect the characteristics and reliability of the product.

### 1.2 Electrical Absolute Maximum Ratings

#### (1)TFT Module

$V_{SS} = 0\text{ V}$

ITEM	SYMBOL	Min.	Max.	Unit	Note
Power Supply Voltage	VDD	0	13.2	V	
Input Voltage for logic	V1	-0.3	3.6	V	1)
Electrostatic Durability	VESD0	±100		V	2),3)
	VESD1	±8		kV	2),4)

Note 1)It is applied to pixel data signal and clock signal.

2)Discharge Coefficient : 200pF-250Ω, Environmental : 25°C-70%RH

3)It is applied to I/F connector pins.

4)It is applied to the surface of a metallic bezel and a LCD panel.

#### (2) Back-light Inverter

$V_{SS} = 0\text{ V}$

ITEM	SYMBOL	Min.	Max.	Unit	Note
Input Voltage	Vin	0	26.4	V	
ON/OFF Control Input Voltage	ON/OFF	0	6.0	V	
Brightness Control Voltage	PWM	0	3.3	V	

## 2. INITIAL OPTICAL CHARACTERISTICS

The following optical characteristics are measured under stable conditions. It takes about 30 minutes to reach stable conditions. The measuring point is the center of display area unless otherwise noted.

The optical characteristics should be measured in a dark room or equivalent state.

Measuring equipment : CS-1000A, or equivalent

Ambient Temperature =25°C、VDD=12.0V、f V=60Hz、

VBL=24V、PWM on duty =100%

ITEM	SYMBOL	CONDITION	Min.	Typ.	Max.	UNIT	NOTE	
Contrast Ratio	C R	$\theta = 0^\circ$ 1)	500	1000	-	-	2)	
Response Time	Rise		ton	-	8	20	ms	3)
	Fall		toff	-	6	20	ms	3)
Brightness of white	Bwh		320	420	-	cd/m <sup>2</sup>		
Brightness uniformity	Buni		-	-	30	%	4)	
Color Chromaticity (CIE)	Red		$\chi$	0.62	0.65	0.68	-	【Gray scale =255】
			y	0.30	0.33	0.36		
	Green		$\chi$	0.27	0.30	0.33		
			y	0.59	0.62	0.65		
	Blue		$\chi$	0.12	0.15	0.18		
		y	0.04	0.07	0.10			
	White	$\chi$	0.250	0.280	0.310			
		y	0.260	0.290	0.320			
Variation of Color Position (CIE)	Red	$\Delta\chi$	-	-	0.04	-	5) 【Gray scale =255】	
		$\Delta y$	-	-	0.04			
	Green	$\Delta\chi$	$\theta = +50^\circ$ $\varphi = 0^\circ, 90^\circ$ 180°, 270° 1)	-	-			0.04
		$\Delta y$	-	-	0.04			
	Blue	$\Delta\chi$	-	-	0.04			
		$\Delta y$	-	-	0.04			
	White	$\Delta\chi$	-	-	0.04			
		$\Delta y$	-	-	0.04			
Contrast Ratio at 85°	CR85		10	-	-	-	Estimated value	

Note 1) Definition of Viewing Angle

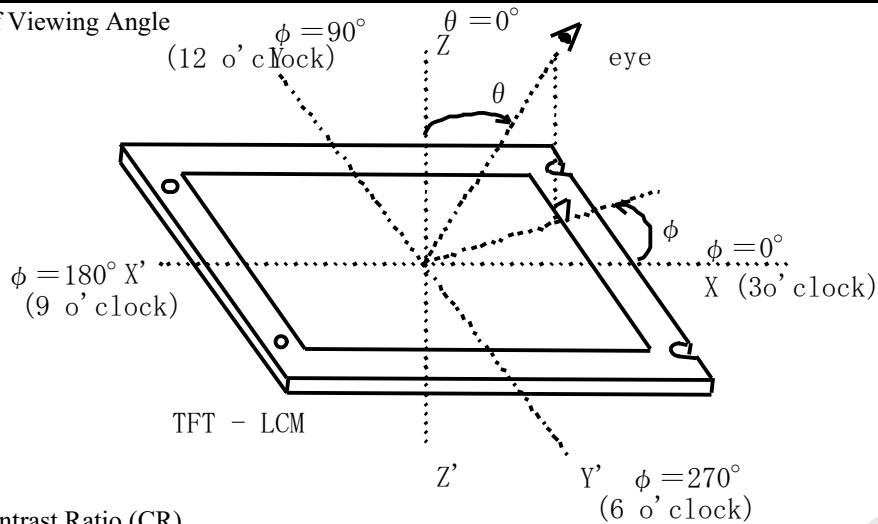

2) Definition of Contrast Ratio (CR)

$$CR = \frac{\text{Luminance at displaying WHITE}}{\text{Luminance at displaying BLACK}}$$

3) Definition of Response Time

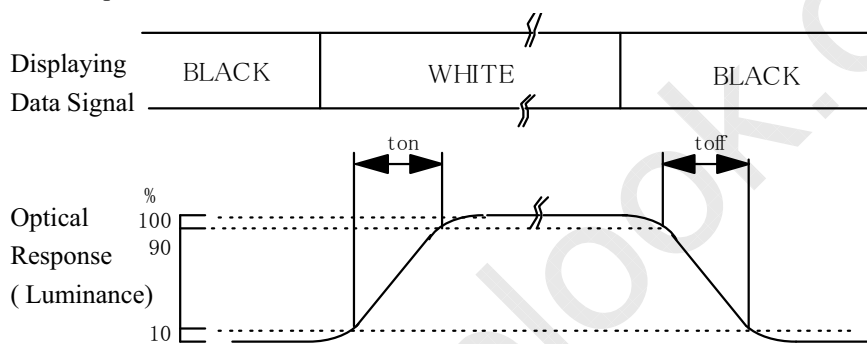

4) Definition of Brightness Uniformity Display pattern is white (255 level). The brightness

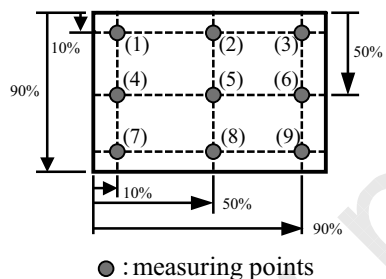

uniformity is defined as the following equation. Brightness at each point is measured, and average, maximum and minimum brightness is calculated.

$$B_{uni} = \frac{|B_{max \text{ or } B_{min}} - B_{ave}|}{B_{ave}} \times 100$$

where, B<sub>max</sub> = Maximum brightness

B<sub>min</sub> = Minimum brightness

$$B_{ave} = \text{Average brightness} = \frac{\sum_{k=1}^9 (B(k))}{9}$$

5) Variation of color position on CIE is defined as difference between colors at  $\theta=0^\circ$  and at  $\theta=+50^\circ$  &  $\phi=0^\circ, 90^\circ, 180^\circ, 270^\circ$ .

### 3. ELECTRICAL CHARACTERISTICS

#### 3.1 TFT-LCD Module

Ta=25°C、Vss=0V

ITEM	SYSTEM	Min.	Typ	Max	單位	備考
Power supply Voltage	VDD	11.4	12.0	12.6	V	
Power supply Current	I DD	-	0.39	0.6	A	1),2)
Ripple voltage of power Supply	VDDR	-	-	350	mV	

Note 1) fV=60.0Hz, fCLK=82MHz, VDD=12.0V, and Display pattern is white.

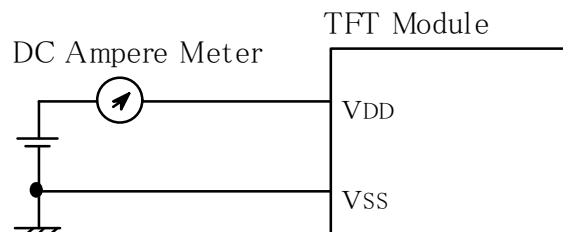

2) Current fuse is built in a module. Current capacity of power supply for VDD should be larger than 4A, so that the fuse can be opened at the trouble of electrical circuit of module.

#### 3.2 Back Light

ITEM	Symbol	Min.	Typ.	Max.	Unit	Notes
Input Voltage	VBL	21.6	24.0	26.4	V	
Input Current	IBL	-	3.2	-	A	VBL=24V, PWM on Duty100% .3)
ON/OFF Control Voltage	ON	2.0	-	5.0	V	
	OFF	0	-	0.8	V	
Brighthness Control Input Voltage	Min. Brightness	-	0	-	V	
	Max. Brightness	-	-	3.3	V	
PWM Duty	Min. Brightness	-	( 20 )	-	%	
	Max. Brightness	-	-	100		

Note 3) This characteristics should be applied putting on the lamp about 60 minutes later with ambient temperature. (Ta=25°C±2°C)

#### 4. BLOCK DIAGRAM

##### (1) TFT Module

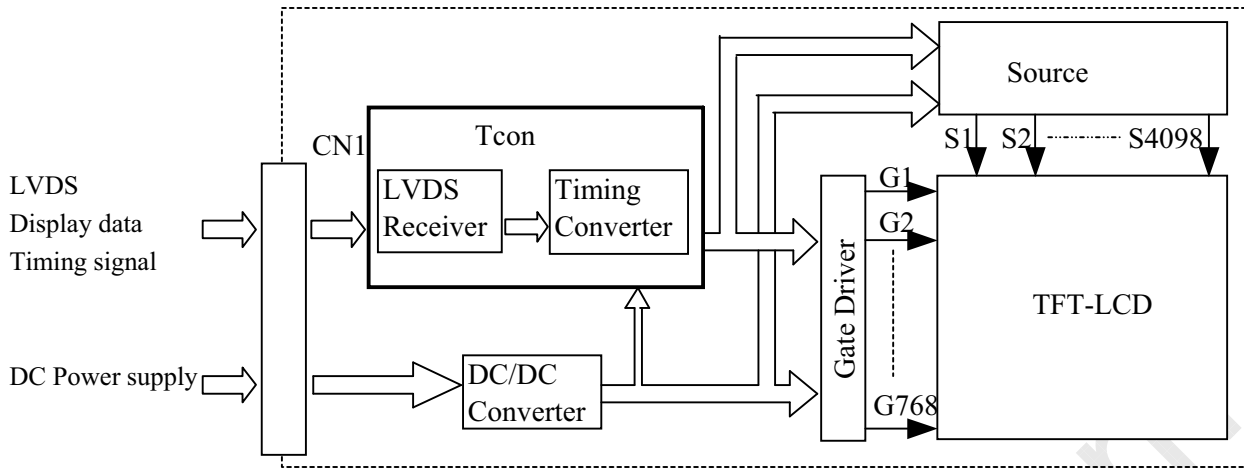

##### (2) Back light unit

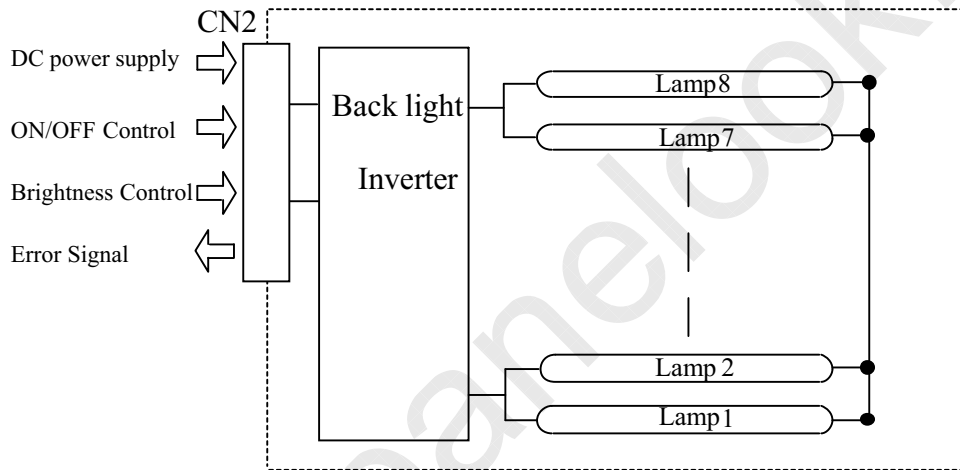



## 5. INTERFACE PIN ASSIGNMENT

### 5.1 TFT-LCD MODULE

CN1:JAE FI-X30SSL-HF

(Matching connector : JAE FI-X30C2L)

Pin No.	SYMBOL	Description	Note
1	VDD	Power Supply (typ.+12V)	1)
2	VDD		
3	VDD		
4	VDD		
5	VSS	GND(0V)	2)
6	VSS		
7	VSS		
8	VSS		
9	IC	Internally Connected, Keep Open	
10	IC		
11	VSS	GND(0V)	
12	Rx0-	Pixel Data	3)
13	Rx0+		
14	VSS	GND(0V)	2)
15	Rx1-	Pixel Data	3)
16	Rx1+		
17	VSS	GND(0V)	2)
18	Rx2-	Pixel Data	3)
19	Rx2+		
20	VSS	GND(0V)	2)
21	CLK-	Pixel Data	3)
22	CLK+		
23	VSS	GND(0V)	2)
24	Rx3-	Pixel Data	3)
25	Rx3+		
26	VSS	GND(0V)	2)
27	IC	Internally Connected, Keep Open	
28	IC		
29	IC		
30	IC		

- Notes
- 1) All VDD pins shall be connected to +12.0V(Typ.).
  - 2) All VSS pins shall be grounded. Metal bezel is internally connected to VSS.
  - 3) Rx n+ and Rx n- (n=0,1,2,3) should be wired by twist-pairs or side-by-side FPC patterns, respectively.

## 5.2 Back light unit

### Inverter pin assignment

JST S14B-PHA-SM-TB(LF)(SN)

(Matching connector : JST PHR-14)

PIN No.	SYMBOL	DESCRIPTION	NOTE
1	V <sub>in</sub>	Power supply ( Typ. +24.0V )	1)
2	V <sub>in</sub>		
3	V <sub>in</sub>		
4	V <sub>in</sub>		
5	V <sub>in</sub>		
6	V <sub>ss</sub>	GND ( 0V )	2)
7	V <sub>ss</sub>		
8	V <sub>ss</sub>		
9	V <sub>ss</sub>		
10	V <sub>ss</sub>		
11	FAIL	Status output (Normal:GND abnormal:open )	
12	ON/OFF	High : LAMP ON(3.3V) Low : LAMP OFF	
13	PWM	14pin low:0-3.3V pulse (120-240Hz ON duty 20-100%)	
14	SELECT	Low:external pwm dimming	

Note 1) All V<sub>in</sub> pins shall be connected to +24.0V(Typ.).

2) All V<sub>ss</sub> pins shall be grounded. Metal bezel is internally connected to V<sub>ss</sub>.

## 5.3 BLOCK DIAGRAM OF INTERFACE

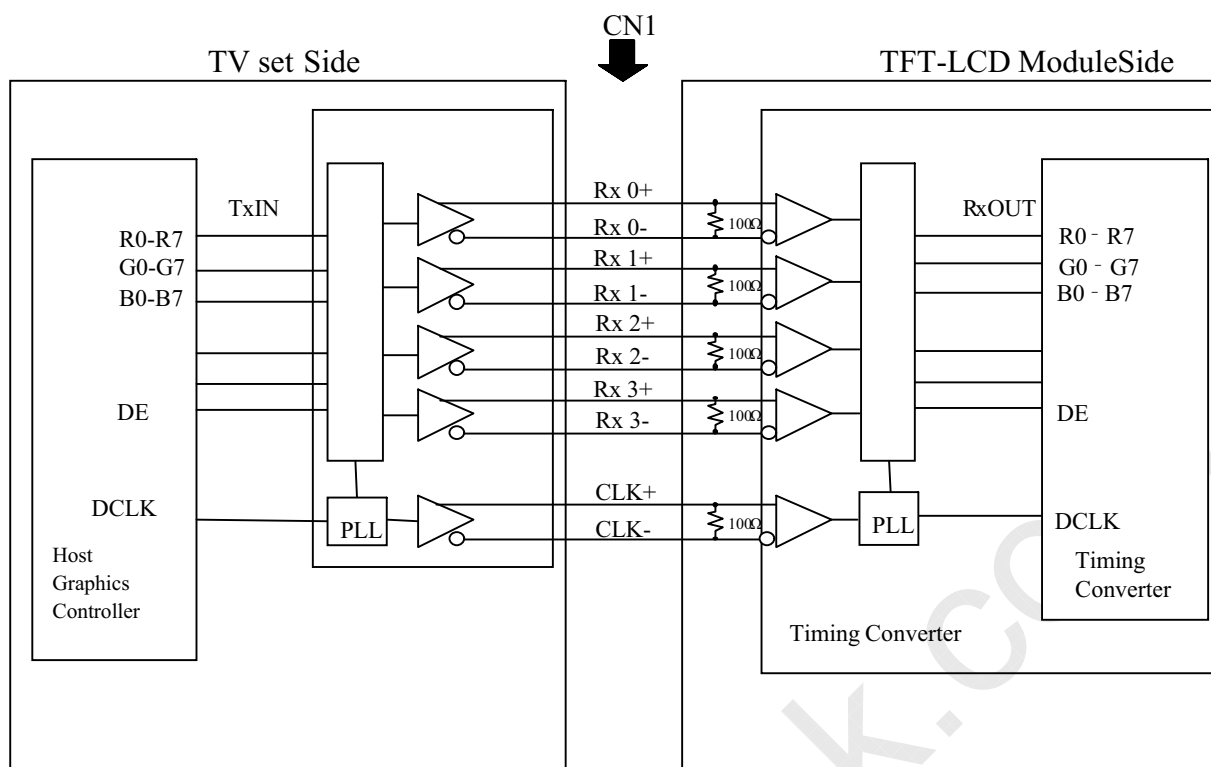

R0~R7 : Pixel R Data (7; MSB, 0; LSB)  
 G0~G7 : Pixel G Data (7; MSB, 0; LSB)  
 B0~B7 : Pixel B Data (7; MSB, 0; LSB)  
 DE : Data Enable

Notes 1) The system must have the transmitter to drive the module.

2) LVDS cable impedance shall be 50 ohms per signal line or about 100 ohms per twist-pair line when it is used differentially.

## 5.4 LVDS INTERFACE

	SIGNAL	TRANSMITTER THC63LVDM83A		INTERFACE CONNECTOR		TFT CONTROL INPUT		
		PIN	INPUT	TV Set	TFT-LCD			
24bit	R2	51	Tx IN0	TA OUT0+	Rx 0+	R2		
	R3	52	Tx IN1			R3		
	R4	54	Tx IN2			R4		
	R5	55	Tx IN3			R5		
	R6	56	Tx IN4			R6		
	R7	3	Tx IN6			TA OUT0-	Rx 0-	R7
	G2	4	Tx IN7					G2
	G3	6	Tx IN8	TA OUT1+	Rx 1+	G3		
	G4	7	Tx IN9			G4		
	G5	11	Tx IN12			G5		
	G6	12	Tx IN13			G6		
	G7	14	Tx IN14			G7		
	B2	15	Tx IN15			TA OUT1-	Rx 1-	B2
	B3	19	Tx IN18					B3
	B4	20	Tx IN19	TA OUT2+	Rx 2+	B4		
	B5	22	Tx IN20			B5		
	B6	23	Tx IN21			B6		
	B7	24	Tx IN22			B7		
	-	27	Tx IN24			not connected		
	-	28	Tx IN25			not connected		
	DE	30	Tx IN26			TA OUT2-	Rx 2-	DE
	R0	50	Tx IN27	TA OUT3+	Rx 3+	R0		
	R1	2	Tx IN5			R1		
	G0	8	Tx IN10			G0		
	G1	10	Tx IN11			G1		
	B0	16	Tx IN16			B0		
	B1	18	Tx IN17			TA OUT3-	Rx 3-	B1
	RSVD 1)	25	Tx IN23					not connected
	DCLK	31	TxCLK IN	TxCLK OUT+	RxCLK IN+	DCLK		
				TxCLK OUT-	RxCLK IN-			

R0~R7 :Pixel B Data (7;MSB, 0;LSB)

G0~G7 :Pixel B Data (7;MSB, 0;LSB)

B0~B7 :Pixel B Data (7;MSB, 0;LSB)

DE :Data Enable

Notes 1) RSVD(reserved) pins on the transmitter shall be tied to"H"or"L".

5.5 CORRESPONDENCE BETWEEN INPUT DATA AND DISPLAY IMAGE

Display data of adjacent one pixel is latched during one cycle of DCLK.

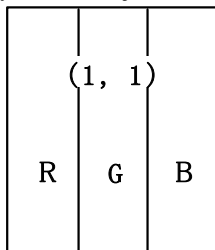

pixel : R0~R7 :R data  
G0~G7 :G data  
B0~B7 :B data

1, 1	1, 2	1, 3	-----	1, 1366
2, 1	2, 2	2, 3	-----	2, 1366
3, 1	3, 2	3, 3	-----	3, 1366
⋮	⋮	⋮		⋮
768, 1	768, 2	768, 3	-----	768, 1366

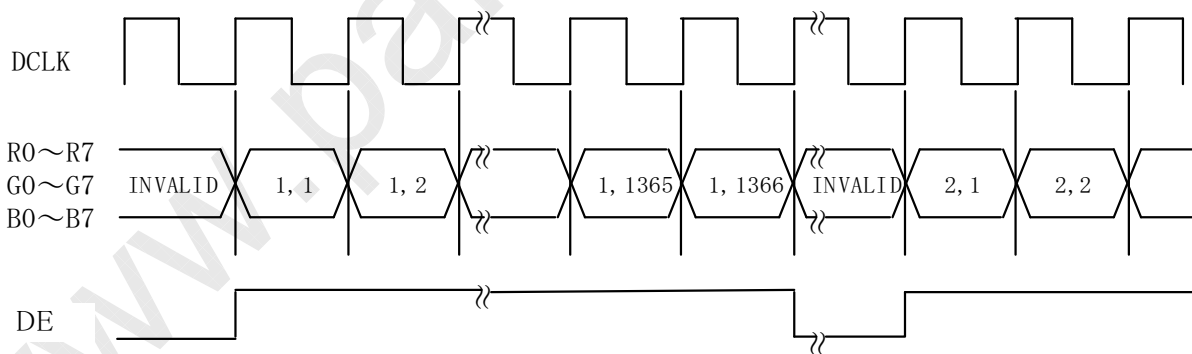

5.6 RELATIONSHIP BETWEEN DISPLAY COLORS AND INPUT SIGNALS

Color	Input	Red Data								Green Data								Blue Data							
		R7	R6	R5	R4	R3	R2	R1	R0	G7	G6	G5	G4	G3	G2	G1	G0	B7	B6	B5	B4	B3	B2	B1	B0
		MSB				LSB				MSB				LSB				MSB				LSB			
Basic Color	Black	0	0	0	0	0	0	0	0	0	0	0	0	0	0	0	0	0	0	0	0	0	0	0	0
	Red(255)	1	1	1	1	1	1	1	1	0	0	0	0	0	0	0	0	0	0	0	0	0	0	0	0
	Green(255)	0	0	0	0	0	0	0	0	1	1	1	1	1	1	1	1	0	0	0	0	0	0	0	0
	Blue(255)	0	0	0	0	0	0	0	0	0	0	0	0	0	0	0	0	1	1	1	1	1	1	1	1
	Cyan	0	0	0	0	0	0	0	0	1	1	1	1	1	1	1	1	1	1	1	1	1	1	1	1
	Magenta	1	1	1	1	1	1	1	1	0	0	0	0	0	0	0	0	1	1	1	1	1	1	1	1
	Yellow	1	1	1	1	1	1	1	1	1	1	1	1	1	1	1	1	0	0	0	0	0	0	0	0
Red	White	1	1	1	1	1	1	1	1	1	1	1	1	1	1	1	1	1	1	1	1	1	1	1	1
	Black	0	0	0	0	0	0	0	0	0	0	0	0	0	0	0	0	0	0	0	0	0	0	0	0
	Red (1)	0	0	0	0	0	0	0	1	0	0	0	0	0	0	0	0	0	0	0	0	0	0	0	0
	Red (2)	0	0	0	0	0	0	1	0	0	0	0	0	0	0	0	0	0	0	0	0	0	0	0	0
	:	:	:	:	:	:	:	:	:	:	:	:	:	:	:	:	:	:	:	:	:	:	:	:	:
	:	:	:	:	:	:	:	:	:	:	:	:	:	:	:	:	:	:	:	:	:	:	:	:	:
	Red(254)	1	1	1	1	1	1	1	0	0	0	0	0	0	0	0	0	0	0	0	0	0	0	0	0
Green	Red(255)	1	1	1	1	1	1	1	1	0	0	0	0	0	0	0	0	0	0	0	0	0	0	0	0
	Black	0	0	0	0	0	0	0	0	0	0	0	0	0	0	0	0	0	0	0	0	0	0	0	0
	Green (1)	0	0	0	0	0	0	0	0	0	0	0	0	0	0	0	1	0	0	0	0	0	0	0	0
	Green (2)	0	0	0	0	0	0	0	0	0	0	0	0	0	0	1	0	0	0	0	0	0	0	0	0
	:	:	:	:	:	:	:	:	:	:	:	:	:	:	:	:	:	:	:	:	:	:	:	:	:
	:	:	:	:	:	:	:	:	:	:	:	:	:	:	:	:	:	:	:	:	:	:	:	:	:
	Green(254)	0	0	0	0	0	0	0	0	1	1	1	1	1	1	1	0	0	0	0	0	0	0	0	0
Blue	Green(255)	0	0	0	0	0	0	0	0	1	1	1	1	1	1	1	1	0	0	0	0	0	0	0	0
	Black	0	0	0	0	0	0	0	0	0	0	0	0	0	0	0	0	0	0	0	0	0	0	0	0
	Blue (1)	0	0	0	0	0	0	0	0	0	0	0	0	0	0	0	0	0	0	0	0	0	0	0	1
	Blue (2)	0	0	0	0	0	0	0	0	0	0	0	0	0	0	0	0	0	0	0	0	0	0	1	0
	:	:	:	:	:	:	:	:	:	:	:	:	:	:	:	:	:	:	:	:	:	:	:	:	:
	:	:	:	:	:	:	:	:	:	:	:	:	:	:	:	:	:	:	:	:	:	:	:	:	:
	Blue (254)	0	0	0	0	0	0	0	0	0	0	0	0	0	0	0	0	1	1	1	1	1	1	1	0
Blue (255)	0	0	0	0	0	0	0	0	0	0	0	0	0	0	0	0	1	1	1	1	1	1	1	1	

Notes 1) Definition of gray scale:

Color(n) . . . . Number in parenthesis indicates gray scale level. Larger n corresponds to brighter level.

2) Data: 1:High, 0:Low

## 6. INTERFACE TIMING

### 6.1 LVDS receiver timing

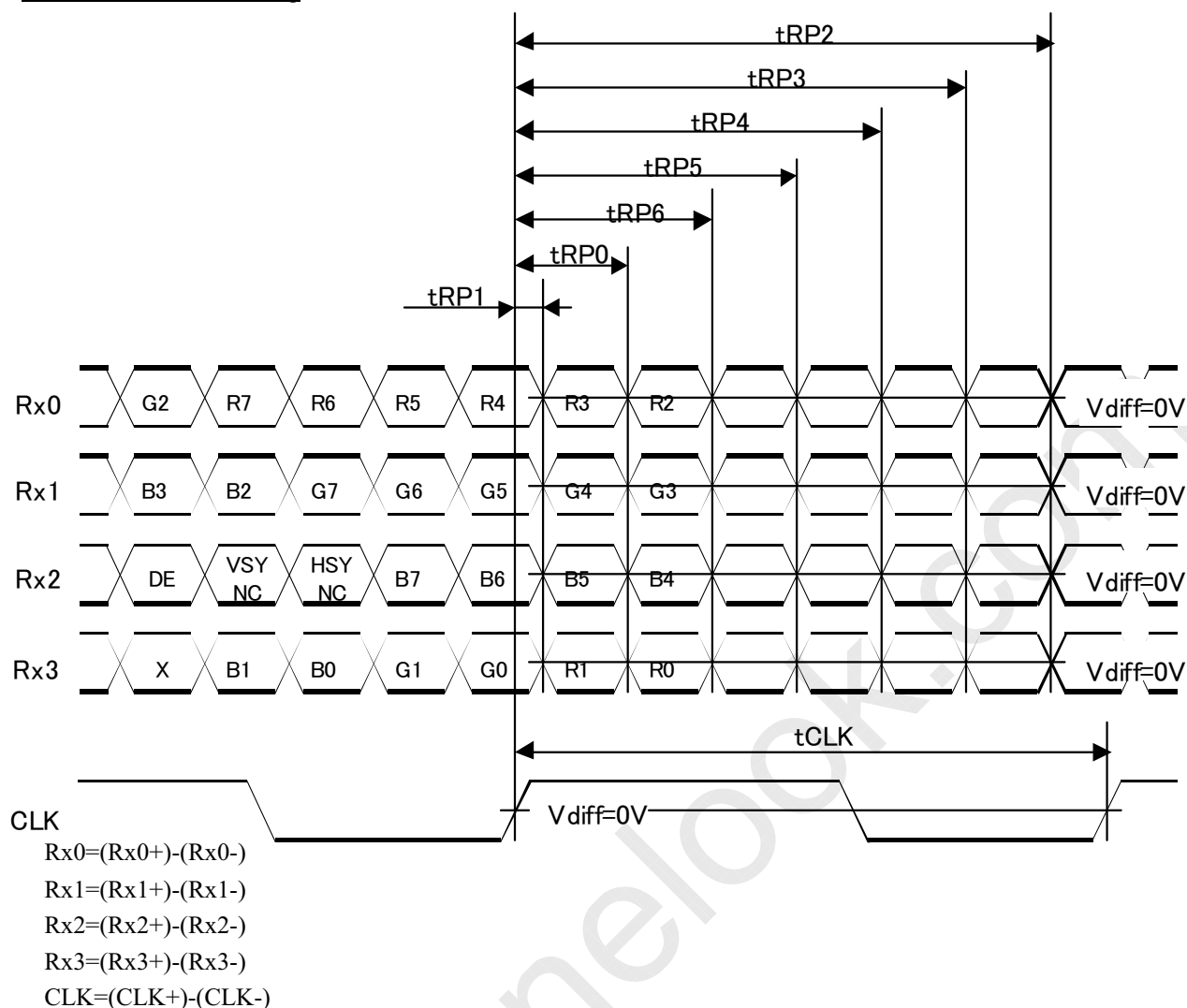

Item	Symbol	Min	Typ	Max	Unit	
RCLK	Frequency	tCLK	65	82	85	MHz
Rx0 Rx1 Rx2 Rx3	0 data position	tRIP0	$1/7tCLK - 0.41$	$1/7tCLK$	$1/7tCLK + 0.41$	ns
	1st data position	tRIP1	-0.41	0	+0.41	
	2nd data position	tRIP2	$6/7tCLK - 0.41$	$6/7tCLK$	$6/7tCLK + 0.41$	
	3rd data position	tRIP3	$5/7tCLK - 0.41$	$5/7tCLK$	$5/7tCLK + 0.41$	
	4th data position	tRIP4	$4/7tCLK - 0.41$	$4/7tCLK$	$4/7tCLK + 0.41$	
	5th data position	tRIP5	$3/7tCLK - 0.41$	$3/7tCLK$	$3/7tCLK + 0.41$	
	6th data position	tRIP6	$2/7tCLK - 0.41$	$2/7tCLK$	$2/7tCLK + 0.41$	

## 6.2 SYNCHRONIZATION SIGNAL TIMING

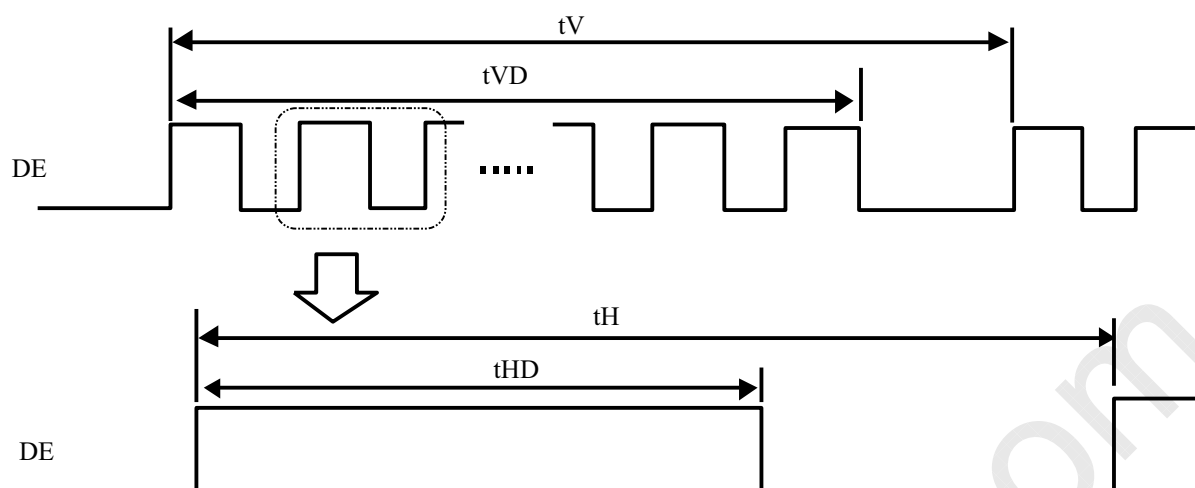

## I) 50Hz

	ITEM	SYMBOL	Min.	Typ.	Max.	UNIT	NOTE
DE	Vertical frequency	fV	48	50	52	Hz	
	Vertical period	tV	773	860	1000	tH	
	Vertical valid	tVD	768			tH	
	Horizontal frequency	fH	-	43	-	kHz	
	Horizontal period	tH	1400	1814	2000	tCLK	
	Horizontal valid	tHD	1366			tCLK	

## II) 60Hz

	ITEM	SYMBOL	Min.	Typ.	Max.	UNIT	NOTE
DE	Vertical frequency	fV	58	60	62	Hz	
	Vertical period	tV	773	773	1000	tH	
	Vertical valid	tVD	768			tH	
	Horizontal frequency	fH	-	46.4	-	kHz	
	Horizontal period	tH	1400	1833	2000	tCLK	
	Horizontal valid	tHD	1366			tCLK	



## 6.3 TIMING BETWEEN INTERFACE SIGNALS POWER SUPPLY

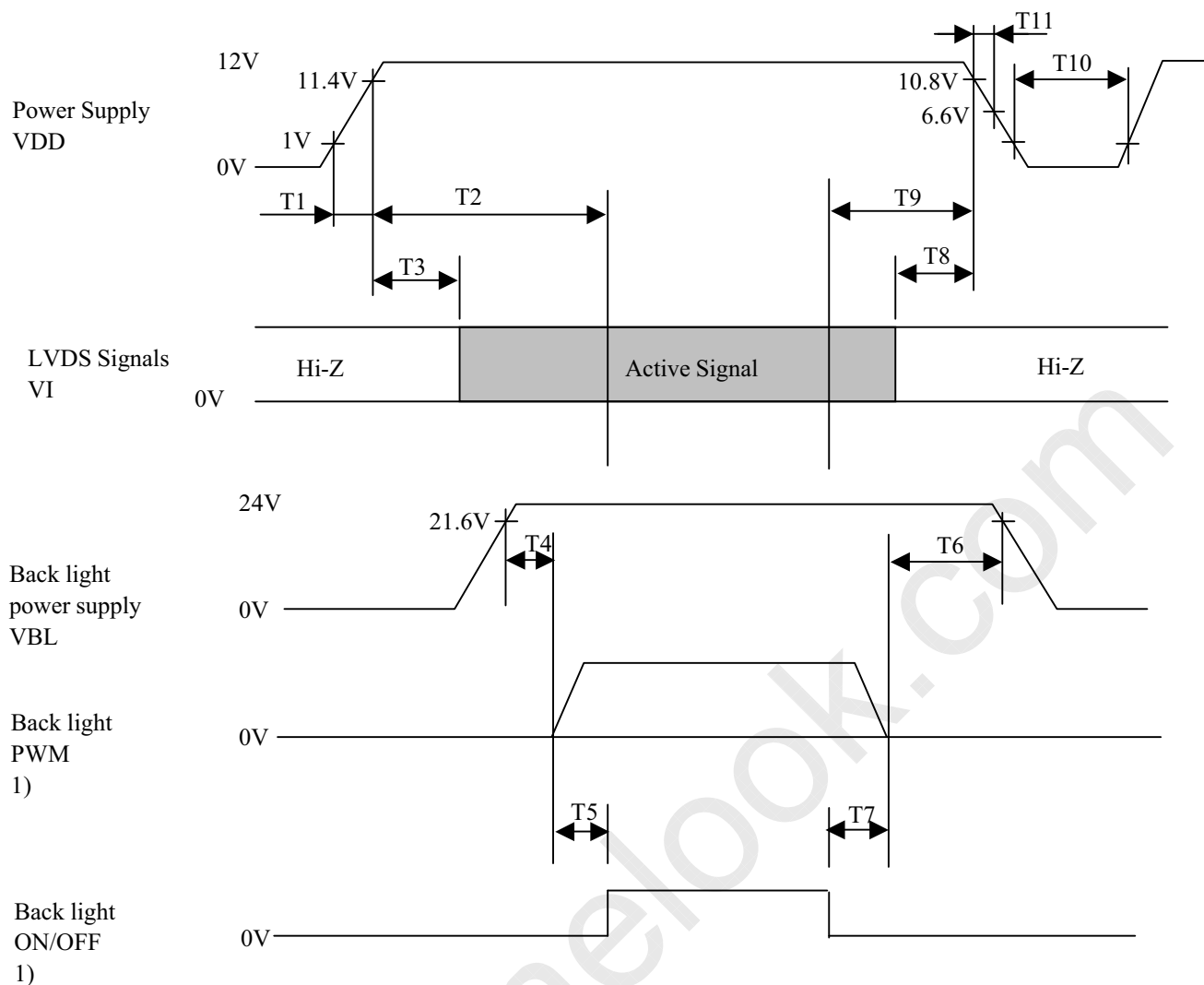

$$0.5 \leq T1 \leq 10$$

$$350 \leq T2$$

$$10 \leq T3$$

$$200 \leq T4$$

$$200 \leq T5$$

$$0 \leq T6$$

$$0 \leq T7$$

$$0 \leq T8$$

$$0 \leq T9$$

$$1000 \leq T10$$

$$10 < T11$$

Unit : ms

Note 1) In all periods, the backlight ON/OFF signal voltage and the PWM signal voltage should be lower than the backlight power supply voltage.

## 7. DIMENSIONAL OUT LINE

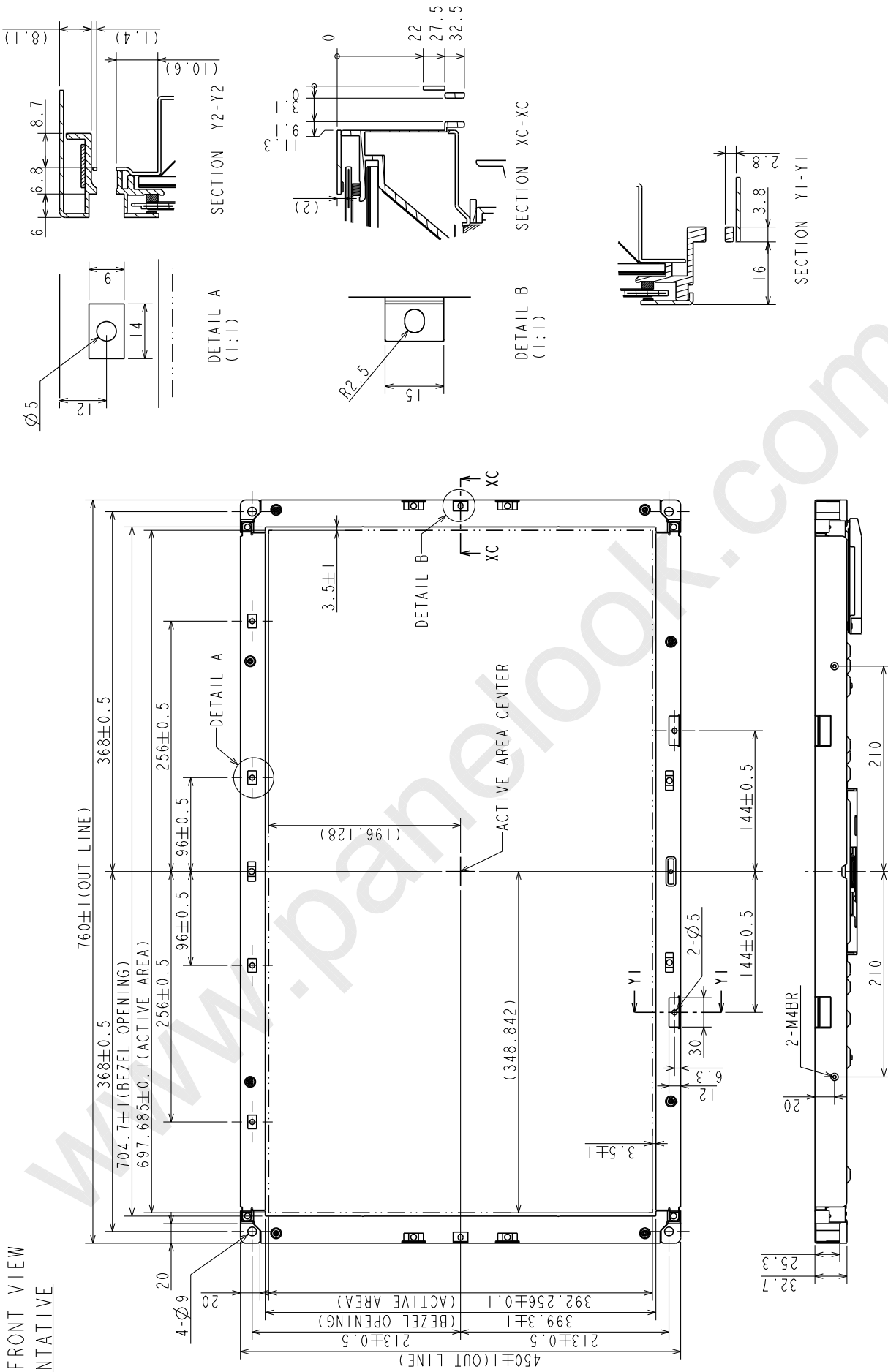
(1) FRONT VIEW  
INITIATIVE

Note 1) The dimension in a parenthesis is a reference value.  
 2) Unspecified tolerance to be  $\pm 0.8$

IPS Alpha Technology, Ltd.

Date

Mar. 23. 2009

Sh.  
No.

ATD1403 2610 AX080B058G

Page

10-1/3

(2)BACK VIEW I  
INITIATIVE

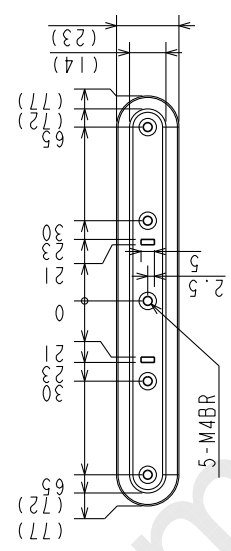
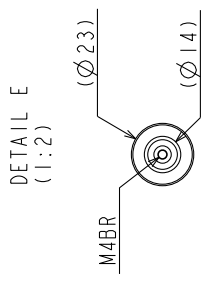
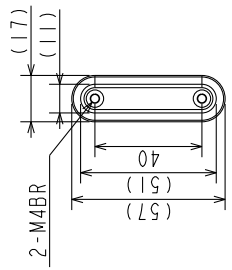
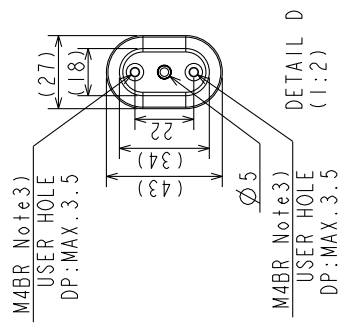
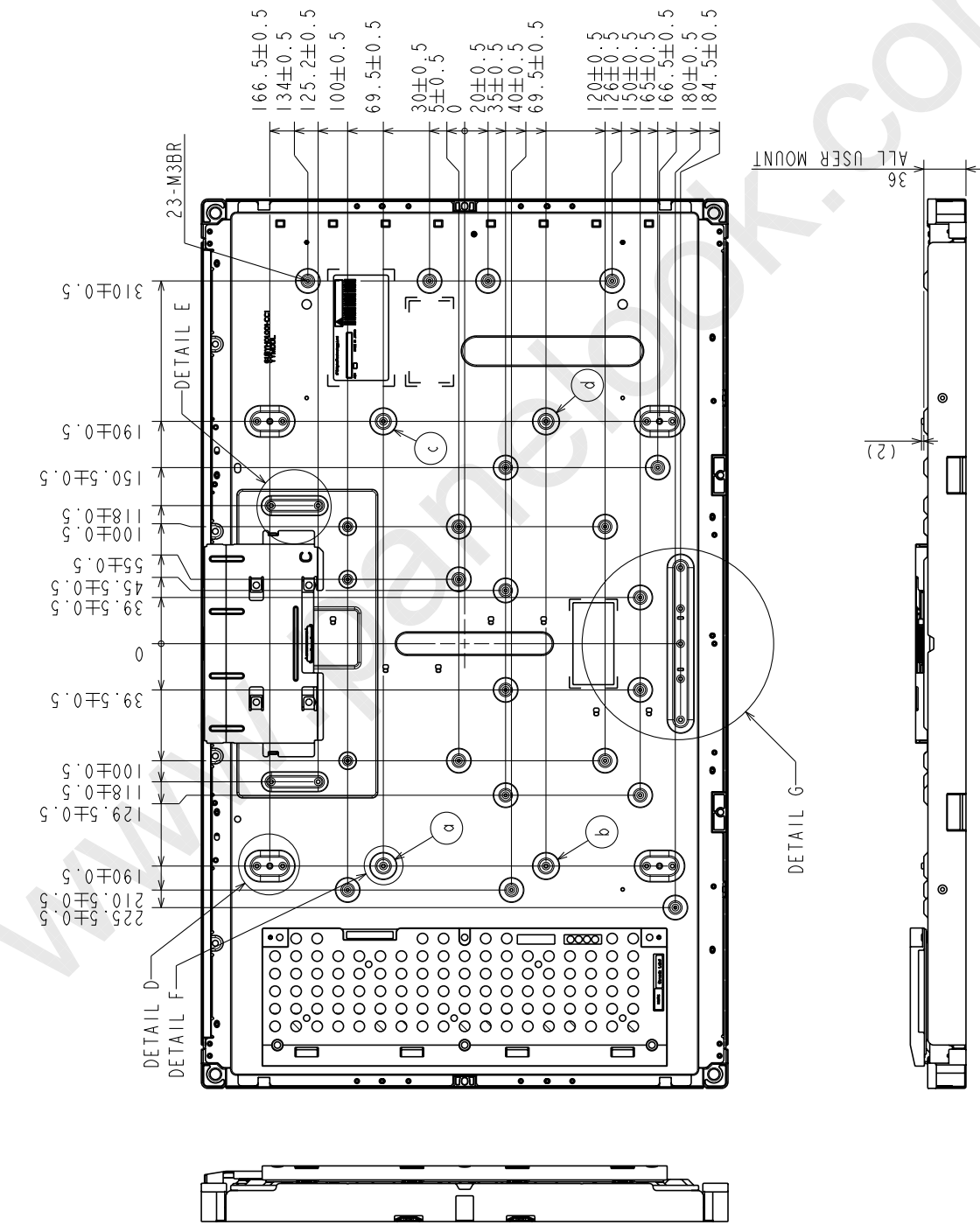

Note 1) The dimension in a parenthesis is a reference value.  
 2) Unspecified tolerance to be ±0.8  
 3) Torque MAX. 1.47N·m(15kgf·cm)

IPS Alpha Technology, Ltd.	Date	Mar. 23. 2009	Sh. No.	ATD1403 2610 AX080B058G	Page	10-2/3
----------------------------	------	---------------	---------	-------------------------	------	--------

(3) BACK VIEW 2  
TENTATIVE

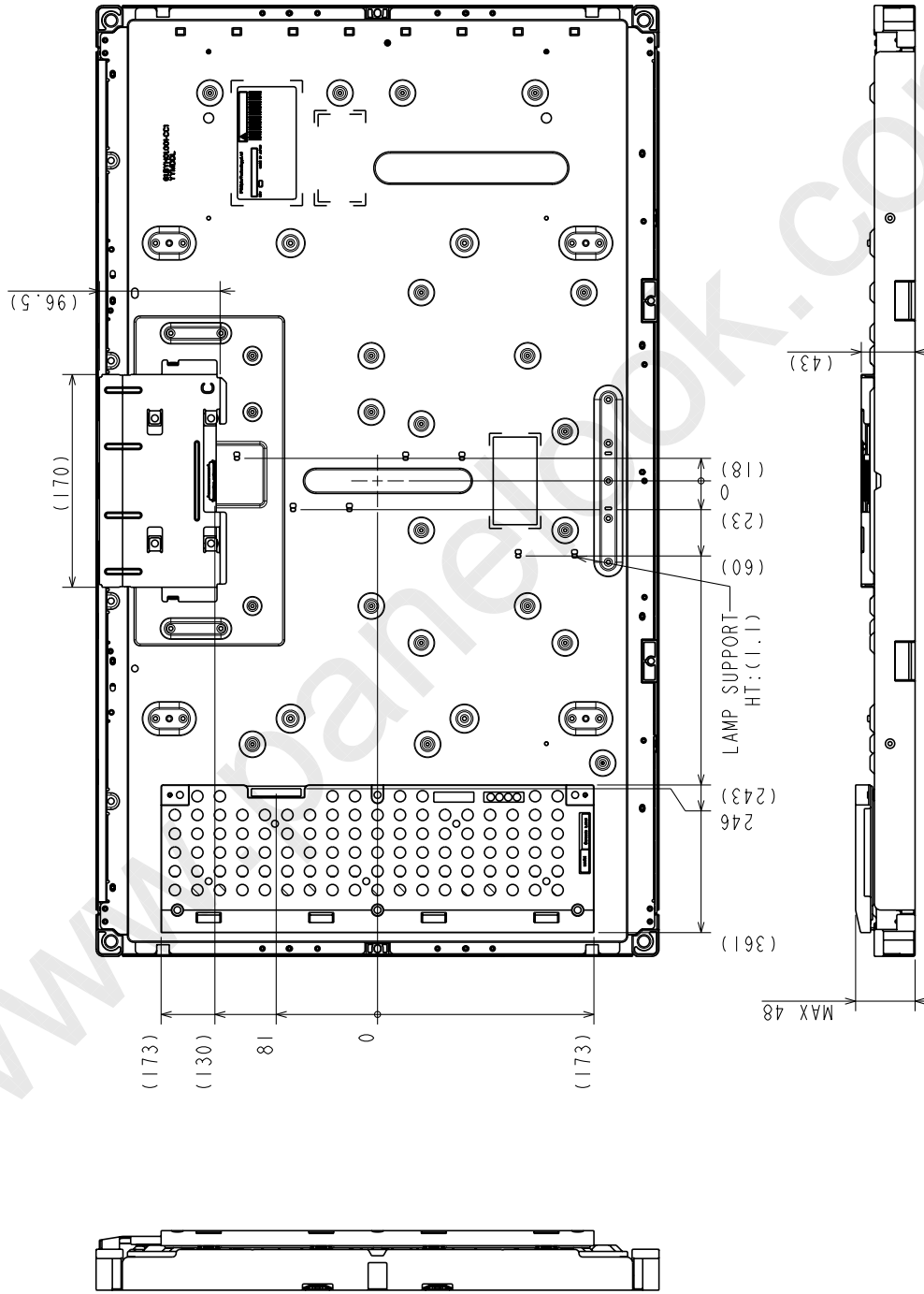

Note 1) The dimension in a parenthesis is a reference value.  
2) Unspecified tolerance to be  $\pm 0.8$

IPS Alpha Technology, Ltd.

Date

Mar. 23. 2009

Sh. No.

ATD1403 2610 AX080B058G

Page 10-3/13