

400mA Low Dropout Linear Regulator

❖ GENERAL DESCRIPTION

AX1113 is a low dropout positive adjustable or fixed-mode regulator with minimum of 400mA output current capability. The product is specifically designed to provide well-regulated supply for low voltage IC applications such as high-speed bus termination and low current 5V logic supply. AX1113 is also well suited for other applications such as VGA cards. AX1113 is guaranteed to have lower than 1.2V dropout at full load current.

❖ FEATURES

- 3-Terminal Adjustable or Fixed 1.8V, 3.3, 5.0V
- Fast transient response
- Output current limiting
- Built-in thermal shutdown
- Good noise rejection
- Packages: SOT89-3L

❖ BLOCK DIAGRAM

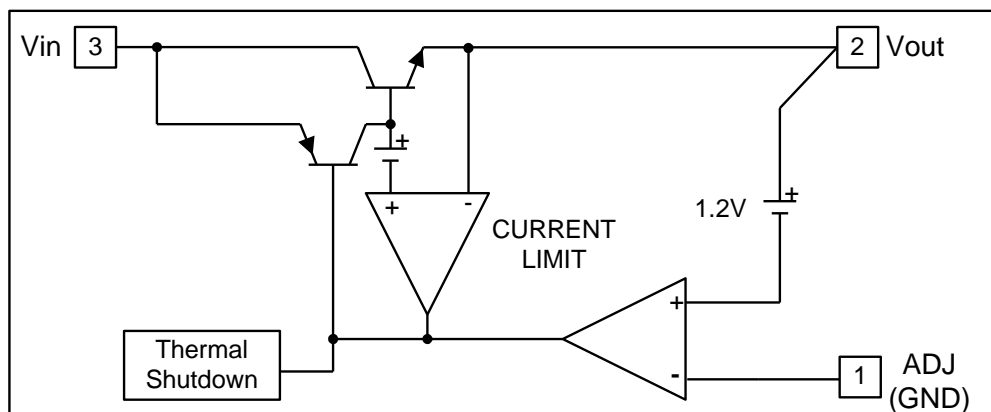

❖ **PIN ASSIGNMENT**

The package of AX1113 is SOT89-3L; the pin assignment is given by:

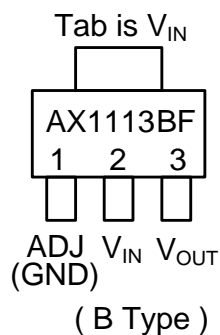
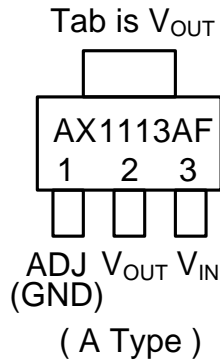

Name	Description
ADJ (GND)	A resistor divider from this pin to the V _{OUT} pin and ground sets the output voltage. (Ground only for Fixed-Mode)
V _{OUT}	The output of the regulator. A minimum of 10uF capacitor (0.15Ω ≤ ESR ≤ 20Ω) must be connected from this pin to ground to insure stability.
V _{IN}	The input pin of regulator. Typically a large storage capacitor (0.15Ω ≤ ESR ≤ 20Ω) is connected from this pin to ground to insure that the input voltage does not sag below the minimum dropout voltage during the load transient response. This pin must always be 1.2V higher than V _{OUT} in order for the device to regulate properly.

❖ **ORDER/MARKING INFORMATION**

Order Information	Top Marking
<p>AX 1113 XXX</p> <ul style="list-style-type: none"> Type: A: 3.3V (A Type), B: 3.3V (B Type), C: 1.8V (A Type), D: 1.8V (B Type), E: ADJ (A Type), F: ADJ (B Type), G: 5.0V (A Type), H: 5.0V (B Type) Package: F: SOT89-3L Packing: Blank: Bag, A : Taping 	<p>1 1 1 3 → Part number L Y W X → ID code: internal WW: 01~26(A~Z), 27~52(a~z) Year: A=2010, 1=2011</p> <p>Output Type: A:AX1113AF B:AX1113BF C:AX1113CF D:AX1113DF E:AX1113EF F:AX1113FF G:AX1113GF H:AX1113HF</p>

❖ **ABSOLUTE MAXIMUM RATINGS**

Characteristics	Symbol	Rating	Unit
DC Supply Voltage	V _{IN}	-0.3 to 15	V
Operating Junction Temperature Range	T _{OP}	-40 to +125	°C
Maximum junction Temperature	T _{MJ}	150	°C
Power Dissipation (multi-layer PCB copper area 5mm*5mm) T _A =25°C, T _J =125°C, SOT89	P _D	625	mW
Storage Temperature	T _{ST}	-65 to +150	°C

❖ ELECTRICAL CHARACTERISTICS

(Under Operating Conditions)

Characteristics	Conditions		Min	Typ	Max	Units
Operation Input Voltage			2.75	-	12	V
Reference Voltage	AX1113EF/FF	$T_J=25^{\circ}\text{C}, (V_{IN-OUT})=1.5\text{V}, I_{OUT}=10\text{mA}$	1.225	1.250	1.275	V
Output Voltage	AX1113AF/BF	$I_{OUT}=10\text{mA}, T_J=25^{\circ}\text{C}, 4.8\text{V} \leq V_{IN} \leq 12\text{V}$	3.235	3.300	3.365	V
	AX1113CF/DF	$I_{OUT}=10\text{mA}, T_J=25^{\circ}\text{C}, 3.3\text{V} \leq V_{IN} \leq 12\text{V}$	1.764	1.800	1.836	V
	AX1113GF/HF	$I_{OUT}=10\text{mA}, T_J=25^{\circ}\text{C}, 6.5\text{V} \leq V_{IN} \leq 12\text{V}$	4.900	5.000	5.100	V
Line Regulation (Note 1,2)	$I_{OUT}=10\text{mA}, V_{OUT}+1.5\text{V} \leq V_{IN} \leq 12\text{V}, T_J=25^{\circ}\text{C}$		-	9	15	mV
Load Regulation (Note 1,2)	AX1113EF/FF	$V_{IN}=3.3\text{V}, V_{adj}=0, 10\text{Ma} < I_{OUT} < 0.4\text{A}, T_J=25^{\circ}\text{C}$	-	-	0.5	%
	AX1113AF/BF	$V_{IN}=5\text{V}, 10\text{mA} \leq I_{OUT} \leq 0.4\text{A}, T_J=25^{\circ}\text{C}$	-	-	20	mV
	AX1113CF/DF	$V_{IN}=3.3\text{V}, 10\text{mA} < I_{OUT} < 0.4\text{A}, T_J=25^{\circ}\text{C}$	-	-	12	mV
	AX1113GF/HF	$V_{IN}=6.5\text{V}, 10\text{mA} \leq I_{OUT} \leq 0.4\text{A}, T_J=25^{\circ}\text{C}$	-	-	30	mV
Dropout Voltage ($V_{IN}-V_{OUT}$)	$I_{OUT}=400\text{mA}, \Delta V_{OUT}=1\%V_{OUT}$		-	1.1	1.2	V
Current Limit	$(V_{IN}-V_{OUT})=2\text{V}$		0.5	-	-	A
Minimum Load Current	$0^{\circ}\text{C} \leq T_J \leq 125^{\circ}\text{C}$		-	5	10	mA
Ripple Rejection	$F=120\text{Hz}, C_{OUT}=25\text{uF Tantalum}, I_{OUT}=400\text{mA}$		-	60	70	dB
Temperature Stability	$I_{OUT}=10\text{mA}$		-	0.5	-	%
θ_{JA} Thermal Resistance Junction-to-Ambient (Note4)	SOT89		-	160	-	$^{\circ}\text{C/W}$
θ_{JC} Thermal Resistance Junction-to-Case	SOT89		-	100	-	$^{\circ}\text{C/W}$

Note1: See thermal regulation specifications for changes in output voltage due to heating effects. Line and load regulation are measured at a constant junction temperature by low duty cycle pulse testing. Load regulation is measured at the output lead = 1/18" from the package.

Note2: Line and load regulation are guaranteed up to the maximum power dissipation of 33W. Power dissipation is determined by the difference between input and output differential and the output current. Guaranteed maximum power dissipation will not be available over the full input/output range.

Note3: Quiescent current is defined as the minimum output current required in maintaining regulation. At 12V input/output differential the device is guaranteed to regulate if the output current is greater than 10mA.

Note4: Tab is connected to the multi-layer PCB copper area 5mm*5mm.

❖ APPLICATION CIRCUIT

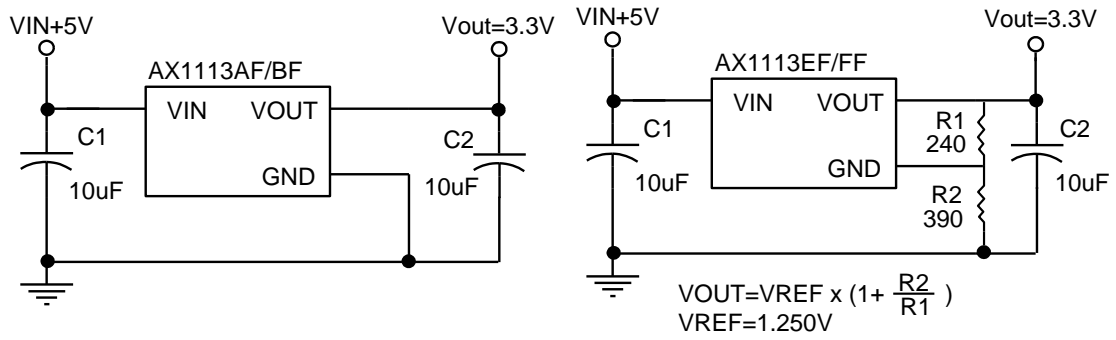

❖ TYPICAL CHARACTERISTICS

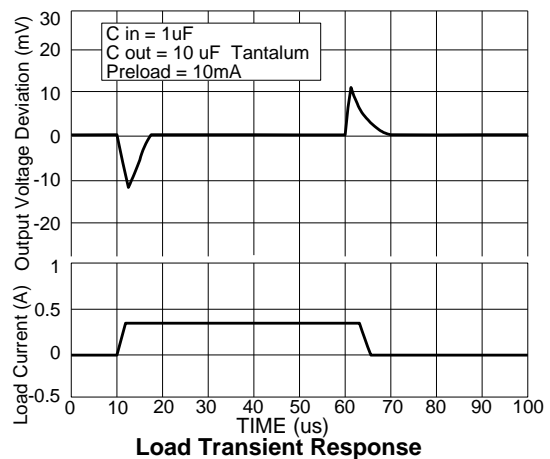
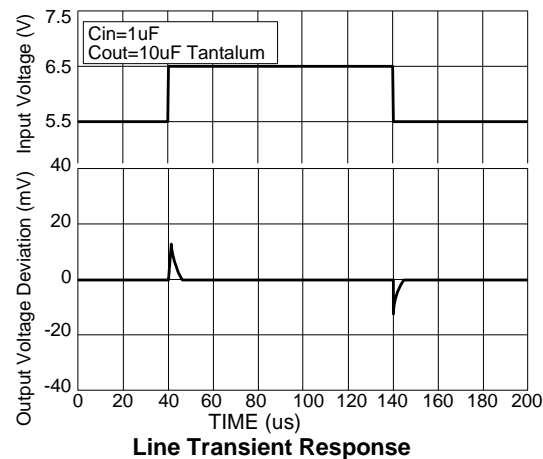
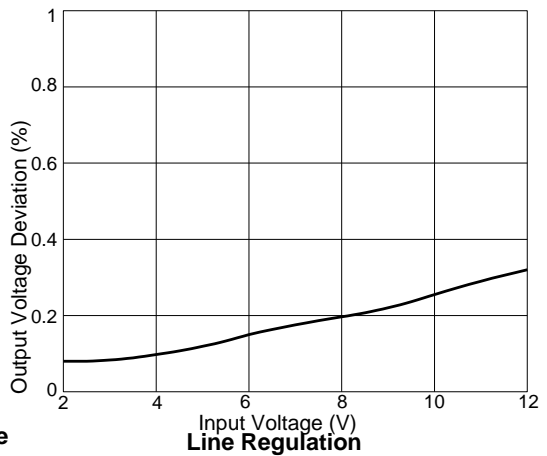
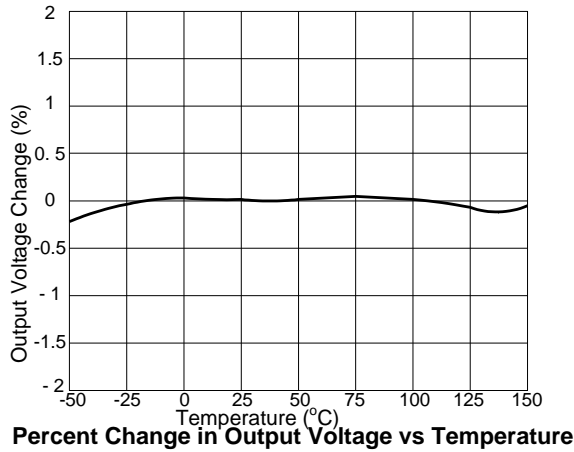
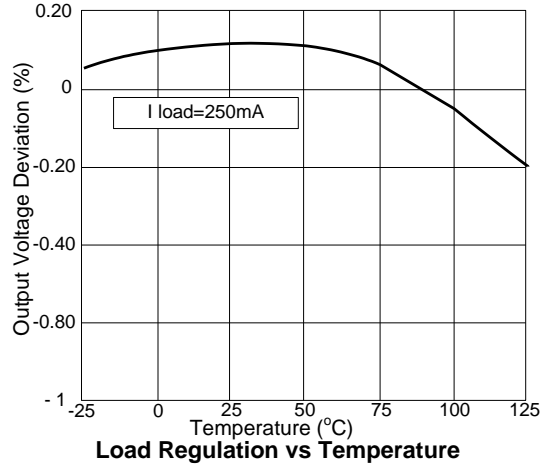
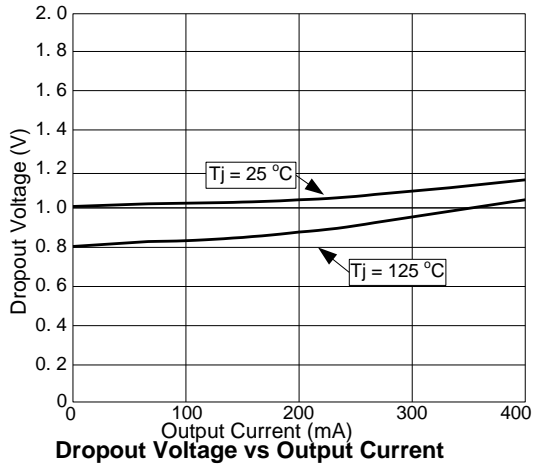

❖ PACKAGE OUTLINES

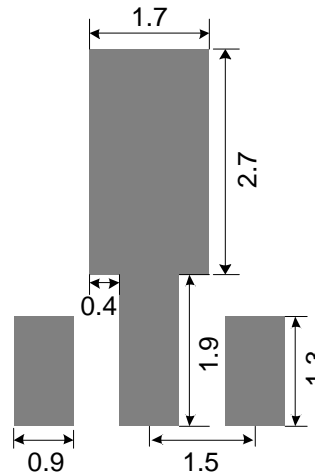
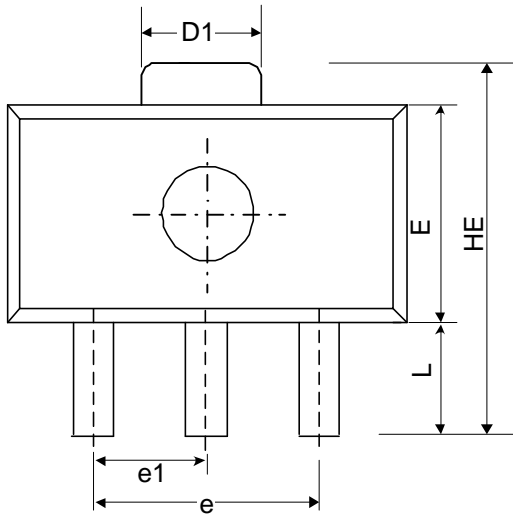

Land Pattern Recommendation (Unit: mm)

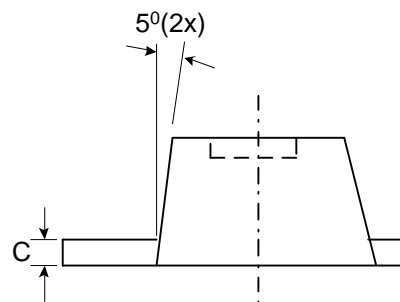
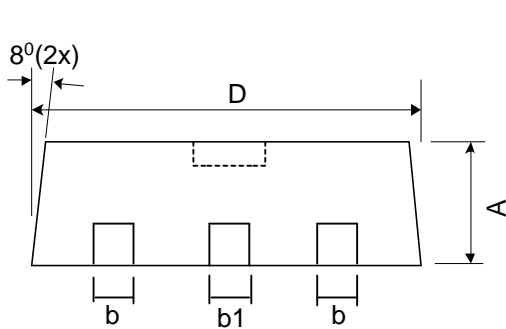

Symbol	Dimensions in Millimeters			Dimensions in Inches		
	Min.	Nom.	Max.	Min.	Nom.	Max.
A	1.4	1.5	1.6	0.055	0.059	0.063
b	0.36	0.42	0.48	0.014	0.017	0.019
b1	0.44	0.5	0.56	0.017	0.02	0.022
C	0.35	0.4	0.44	0.014	0.016	0.017
D	4.4	4.5	4.6	0.173	0.177	0.181
D1	1.35	1.59	1.83	0.053	0.063	0.072
e	3.0 BSC			0.118 BSC		
e1	1.5 BSC			0.059 BSC		
E	2.29	2.45	2.6	0.09	0.097	0.102
HE	3.94	4.1	4.25	0.155	0.161	0.167
L	0.8	1	1.2	0.031	0.04	0.047

JEDEC outline: TO-243 AB