

❖ **PIN ASSIGNMENT**

The package of AX1204 is SOP-8L; the pin assignment is given by:

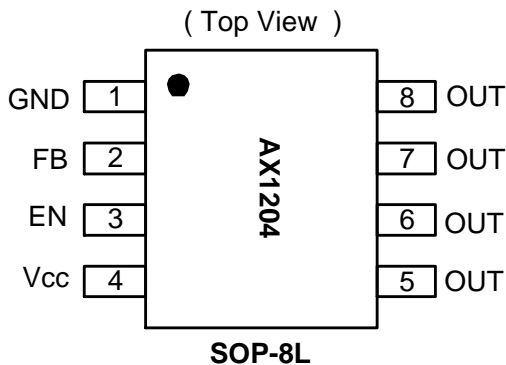

Name	Description
FB	Feedback pin
EN	Enable input, it is pull-high typically. Drive EN high or floating to turn on the regulator, driver it low to turn it off.
VCC	IC power supply pin
OUT	Output Voltage pin
GND	Ground pin

❖ **ORDER/MARKING INFORMATION**

Order Information	
<p>AX1204 X XX X</p> <p>Package Vout Packing</p> <p>S : SOP-8L Blank : Adj Blank : Tube</p> <p> 25 = 2.5V A : Taping</p> <p> 33 = 3.3V</p> <p> 50 = 5.0V</p>	
Top Marking	
<p>ADJ Version</p> <p>Logo ← AX 1 2 0 4 → Part number</p> <p> YY WW X → ID code:internal</p> <p> WW:01~52</p> <p> Year: 10=2010</p> <p> 11=2011</p>	<p>FIXED Version (V_{OUT}=3.3V)</p> <p>Logo ← AX 1 2 0 4 → Part number</p> <p> - 3 3 → Output voltage</p> <p> YY WW X → ID code:internal</p> <p> WW:01~52</p> <p> Year: 10=2010</p> <p> 11=2011</p>

❖ **ABSOLUTE MAXIMUM RATINGS** (T_A=25°C)

Characteristics	Symbol	Rating	Unit
V _{CC} Supply Voltage	V _{CC}	-0.3 to 16	V
EN Pin Voltage	V _{EN}	-0.3 to 7	V
FB Pin Voltage	V _{FB}	-0.3 to V _{CC} +0.3	V
Output current	I _o	1.5	A
Power Dissipation	PD	1.6	W
Storage Temperature Range	T _{ST}	-65 to +150	°C
Junction Temperature Range	T _J	-40 to 125	°C
Operating Temperature Range	T _{OP}	-40 to +85	°C
Thermal Resistance from Junction to case	θ _{JC}	20	°C/W
Thermal Resistance from Junction to ambient	θ _{JA}	60	°C/W

Note: θ_{JA} is measured with the PCB copper area(need connect to OUT pin) of approximately 1.5 in² (Multi-layer).

❖ ELECTRICAL CHARACTERISTICS

(Unless otherwise specified, $T_A=25^{\circ}\text{C}$, $V_{CC}=5\text{V}$)

Characteristics	Symbol	Conditions	Min	Typ	Max	Units
V_{CC} Supply Voltage	V_{CC}	$I_{OUT}=1\text{A}$	3.1	-	12	V
Feedback Voltage	V_{FB}	$I_{OUT}=10\text{mA}$, $V_{CC}=5.0\text{V}$	1.196	1.22	1.244	V
Output Voltage	V_{OUT}	$I_{OUT}=10\text{mA}$, $V_{CC}=3.2\text{V}$	2.45	2.5	2.55	V
		$I_{OUT}=10\text{mA}$, $V_{CC}=4.0\text{V}$	3.234	3.3	3.366	
		$I_{OUT}=10\text{mA}$, $V_{CC}=5.5\text{V}$	4.90	5.0	5.10	
GND Current	I_{GND}	$I_{OUT}=0\sim 1\text{A}$	-	1.2	3	mA
Shutdown Current	I_{SD}	$V_{EN}=0\text{V}$	-	0.1	0.4	mA
Load regulation	V_{Load}	$5\text{mA} < I_{OUT} < 1\text{A}$	-	0.5	1.5	%
Line regulation	V_{Line}	$I_{OUT}=10\text{mA}$, $V_{OUT}+0.5\text{V} < V_{CC} < 12\text{V}$	-	0.1	0.5	%
Ripple rejection ratio	PSRR	Note1	-	65	-	dB
Dropout Voltage	V_{DROP}	$I_{OUT}=1\text{A}$, $V_{OUT}=3.3\text{V}$	-	0.15	0.25	V
		$I_{OUT}=1\text{A}$, $V_{OUT}=5\text{V}$	-	0.1	0.2	
Short circuit protect	I_{scp}	$V_{OUT} < 20\%$	-	0.3	-	A
Current Limit	CL		1.1	-	-	A
EN Pin Logic input threshold voltage	V_{ENH}	High (regulator ON)	2.0	-	-	V
	V_{ENL}	Low (regulator OFF)	-	-	0.8	V
EN Pin Input Current	I_{ENH}	$V_{EN}=2.5\text{V}$ (ON)	-	20	-	μA
	I_{ENL}	$V_{EN}=0.3\text{V}$ (OFF)	-	-10	-	μA
Internal MOSFET RDSON	R_{DSON}	$V_{CC}=3.5\text{V}$,	-	160	190	m Ω
		$V_{CC}=5\text{V}$,	-	130	160	
Thermal Shutdown	T_{SD}		-	140	-	$^{\circ}\text{C}$

Note: These parameters, although guaranteed, are not 100% tested in production.

❖ APPLICATION CIRCUIT

1. FIXED

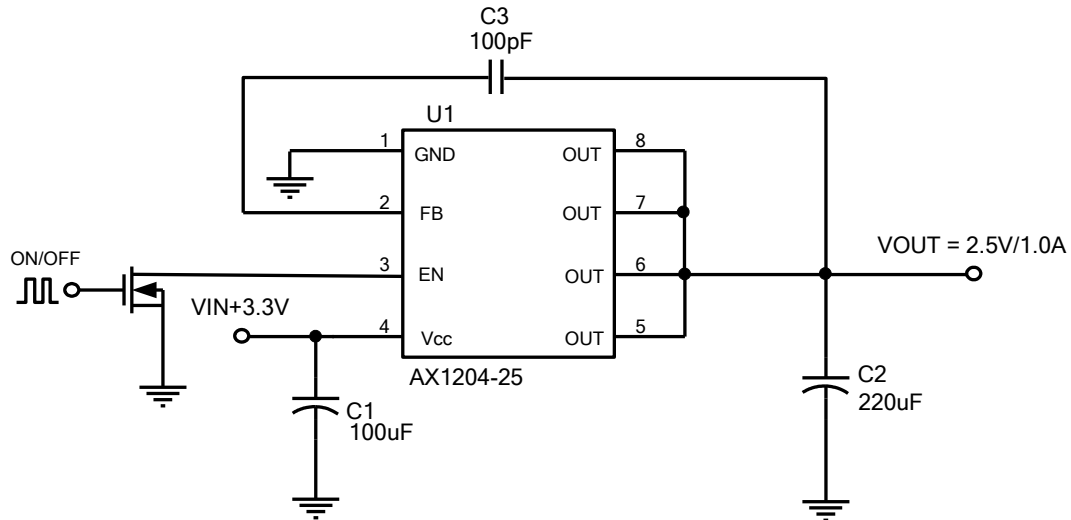

2. ADJ

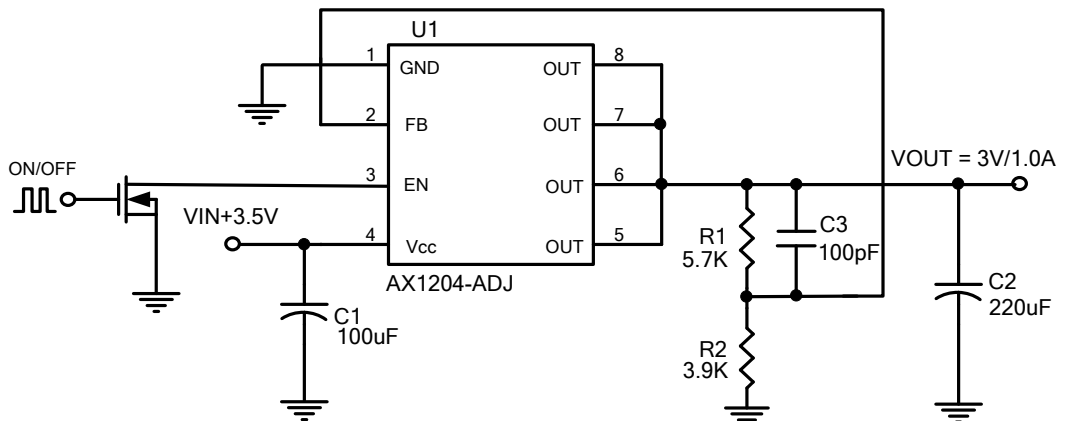

$$V_{OUT} = V_{FB} * (1 + R1/R2)$$

$$V_{FB} = 1.22V$$

R2 suggest 1K~5.6KΩ

C2 choose Low ESR capacitor

C3=47pF~100pF for stability issue

❖ TYPICAL CHARACTERISTICS

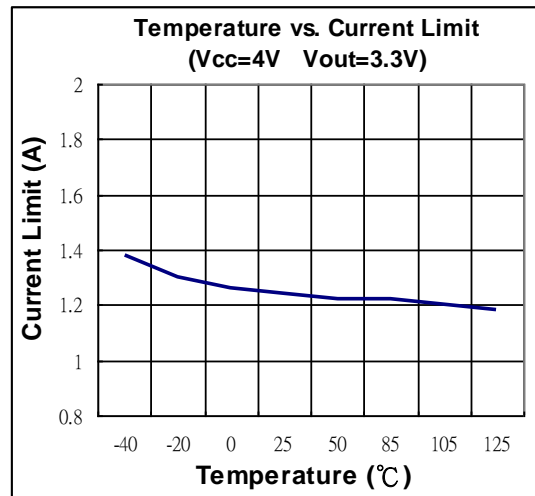
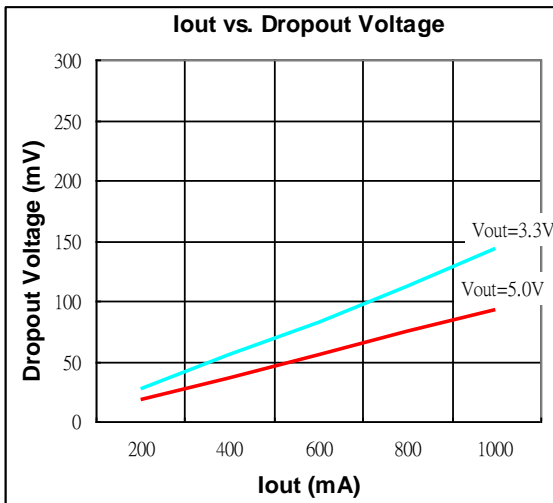
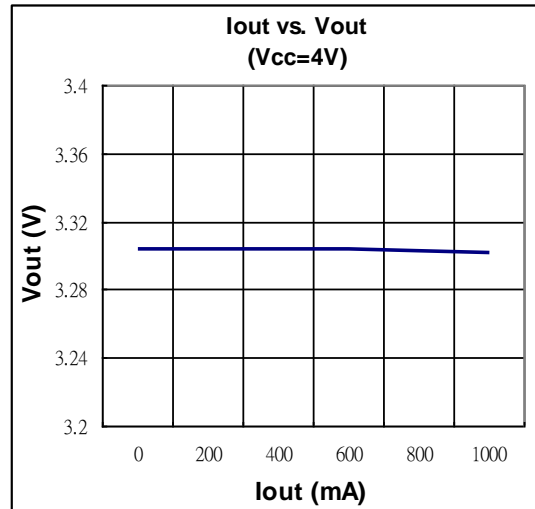
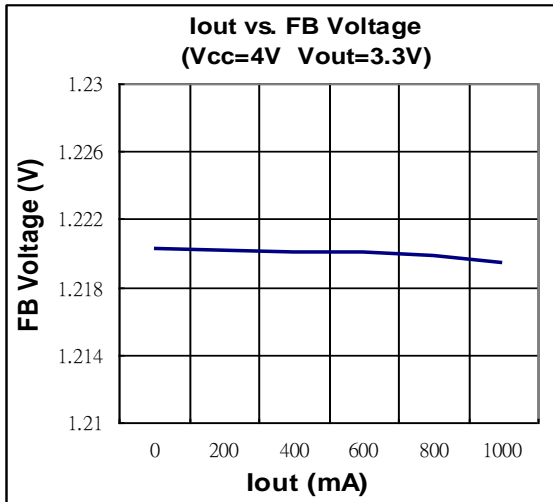
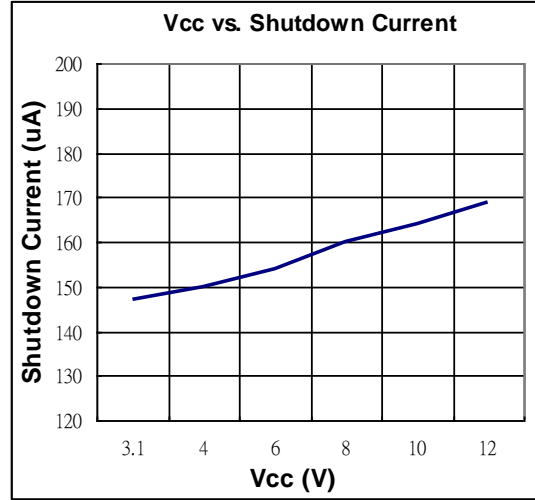
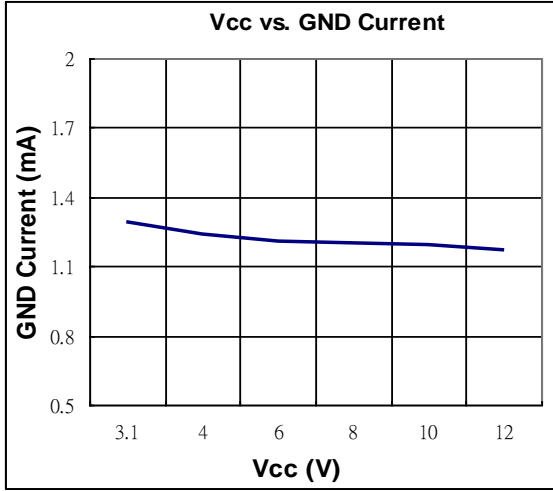

❖ TYPICAL CHARACTERISTICS (CONTINUED)

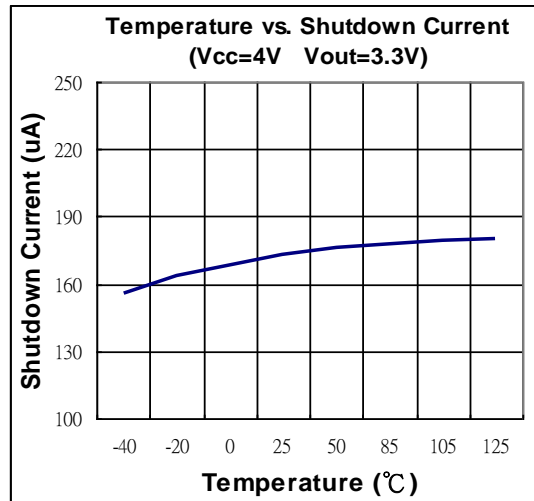
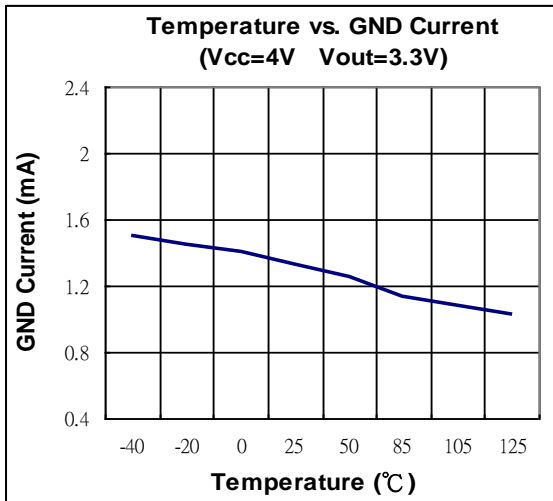
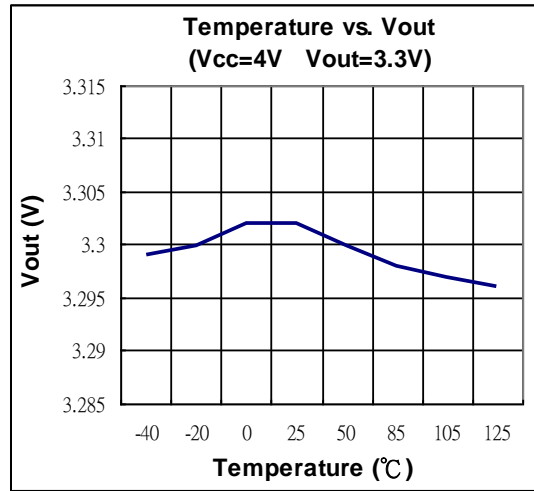
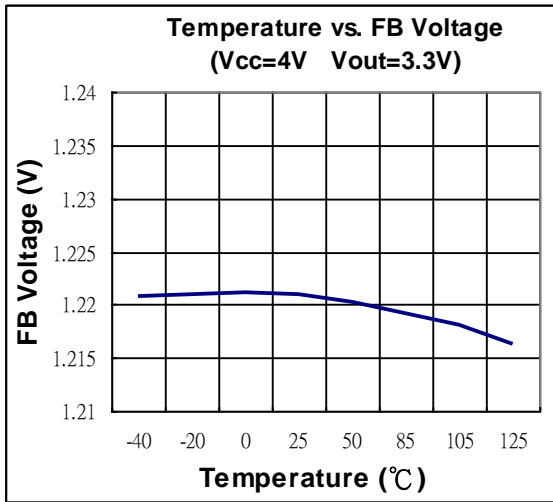

Load Transient
(V_{CC}=5V, V_{OUT}=3.3V, Load=0.1~0.8A)

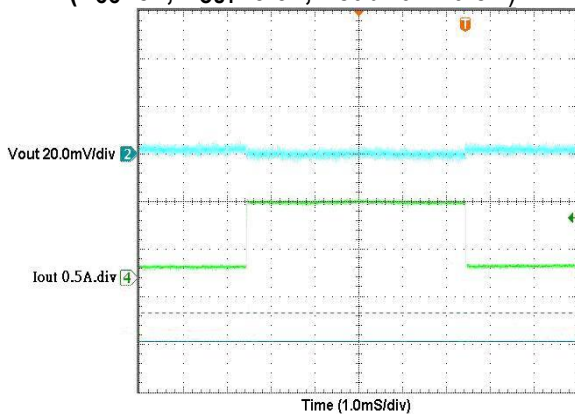

Power-ON
(V_{CC}=5V, V_{OUT} =3.3V, Load=0.8A)

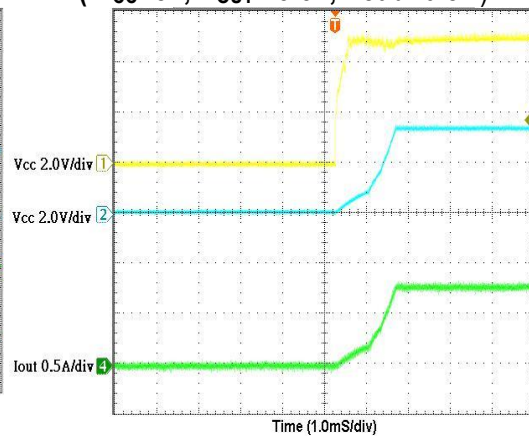

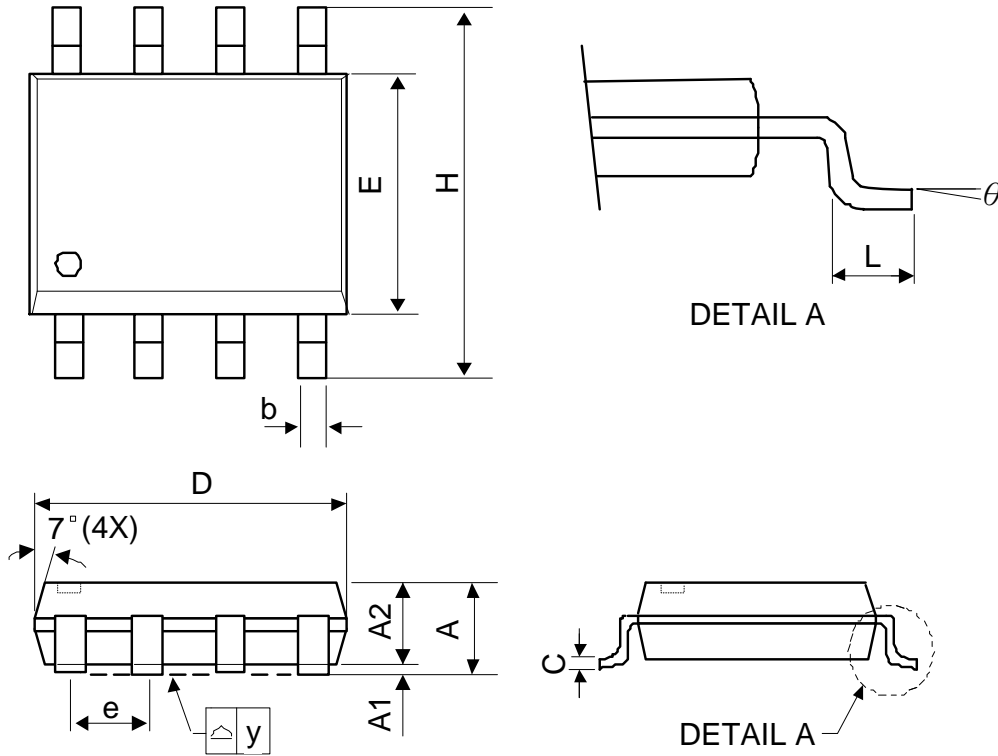
❖ PACKAGE OUTLINES

Symbol	Dimensions in Millimeters			Dimensions in Inches		
	Min.	Nom.	Max.	Min.	Nom.	Max.
A	-	-	1.75	-	-	0.069
A1	0.1	-	0.25	0.04	-	0.1
A2	1.25	-	-	0.049	-	-
C	0.1	0.2	0.25	0.0075	0.008	0.01
D	4.7	4.9	5.1	0.185	0.193	0.2
E	3.7	3.9	4.1	0.146	0.154	0.161
H	5.8	6	6.2	0.228	0.236	0.244
L	0.4	-	1.27	0.015	-	0.05
b	0.31	0.41	0.51	0.012	0.016	0.02
e	1.27 BSC			0.050 BSC		
y	-	-	0.1	-	-	0.004
θ	0°	-	8°	0°	-	8°

Mold flash shall not exceed 0.25mm per side
JEDEC outline: MS-012 AA