

52KHz, 2A PWM Buck DC/DC Converter

❖ GENERAL DESCRIPTION

The AX3007C series are monolithic IC designed for a step-down DC/DC converter, and own the ability of driving a 2A load without additional transistor. It saves board space. The external shutdown function can be controlled by logic level and then come into standby mode. The internal compensation makes feedback control having good line and load regulation without external design. Regarding protected function, thermal shutdown is to prevent over temperature operating from damage, and current limit is against over current operating of the output switch. If current limit function occurs and V_{FB} is down below 0.4V, the switching frequency will be reduced.

The AX3007C series operates at a switching frequency of 52KHz thus allow smaller sized filter components than what would be needed with lower frequency switching regulators. The output version is an adjustable type. The chips are available in standard SOP8, SOP-8L-EP, TO252-5L and TO263-5L packages.

❖ FEATURES

- Output voltage: adjustable and fixed output versions.
- Adjustable version output voltage range is V_{FB} to 38V.
- 52KHz fixed switching frequency.
- Voltage mode non-synchronous PWM control.
- Thermal-shutdown and current-limit protection.
- ON/OFF shutdown control input.
- Short Circuit Protect (SCP).
- Operating voltage can be up to 40V.
- Output load current is up to 2A.
- SOP-8L, SOP-8L-EP, TO252-5L and TO263-5L Pb-Free packages.
- Low power standby mode.
- Built-in switching transistor on chip.

❖ BLOCK DIAGRAM

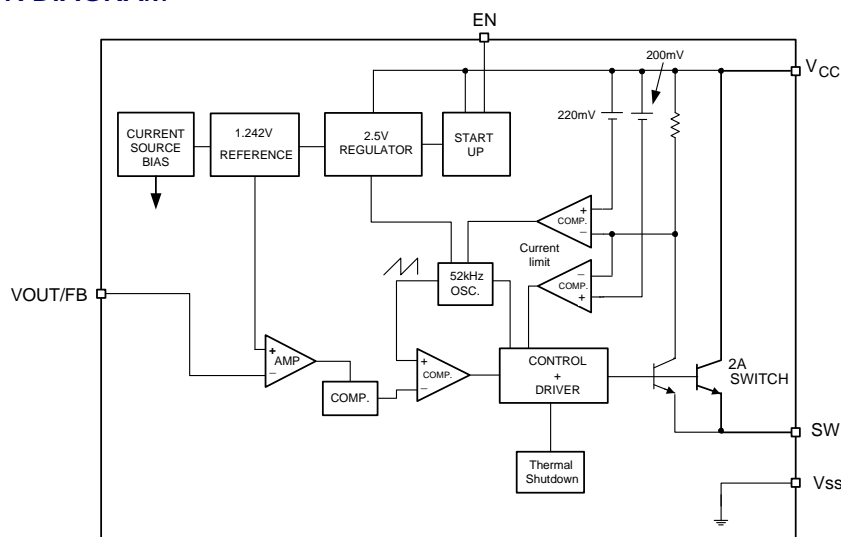

❖ PIN ASSIGNMENT

The packages of AX3007C are SOP-8L, SOP-8L-EP, TO252-5L and TO263-5L. The pin assignment is given by:

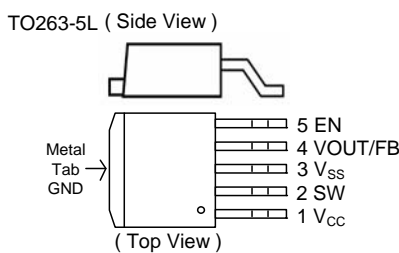
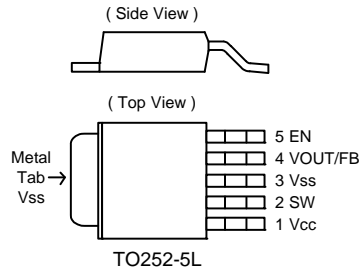
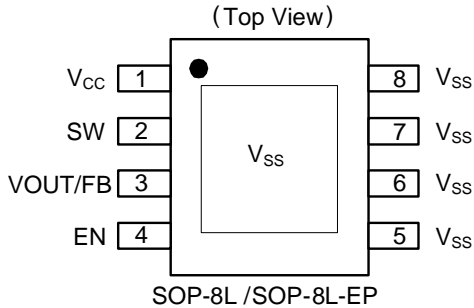

Name	Description
V _{CC}	Operating voltage input
SW	Switching output
VOUT/FB	Output voltage feedback control
EN	ON/OFF Shutdown
V _{SS}	GND pin

❖ ORDER INFORMATION

Order Information	
AX3007C-XX XX X ┌───┬───┬───┐ Output Voltage Package Type Packing 50: 5.0V S: SOP-8L Blank : Tube Blank:ADJ ES: SOP-8L-EP A : Taping D5: TO252-5L M5: TO263-5L	
Top Marking (SOP-8L/SOP-8L-EP)	
ADJ Logo ← AX 3 0 0 7 → Part number C Y Y W W X → ID code:internal ┌──┴──┬──┴──┬──┴──┬──┴──┐ WW:01~52 Year: 10=2010 11=2011 AX3007C	FIX Logo ← AX 3 0 0 7 → Part number - 5 0 → Output voltage C Y Y W W X → ID code:internal ┌──┴──┬──┴──┬──┴──┬──┴──┐ WW:01~52 Year: 10=2010 11=2011 AX3007C
Top Marking (TO252-5L/TO263-5L)	
ADJ Logo ← AX 3 0 0 7 → Part number C → Function code AX3007C Y Y W W X → ID code:internal ┌──┴──┬──┴──┬──┴──┬──┴──┐ WW:01~52 Year: 10=2010 11=2011	FIX Logo ← AX 3 0 0 7 → Part number C - 5 0 → Output voltage Y Y W W X → ID code:internal ┌──┴──┬──┴──┬──┴──┬──┴──┐ WW:01~52 Year: 10=2010 11=2011 AX3007C

❖ ABSOLUTE MAXIMUM RATINGS

Characteristics	Symbol	Rating	Unit
Maximum Supply Voltage	V_{CC}	+45	V
ON/OFF Pin Input Voltage	V_{EN}	-0.3 to V_{CC}	V
Feedback Pin Voltage	V_{FB}	-0.3 to 12	V
Output Voltage to Ground	V_{OUT}	-0.8	V
Power Dissipation Internally limited	PD	$(T_J - T_A) / \theta_{JA}$	W
Storage Temperature Range	T_{ST}	-65 to +165	°C
Junction Temperature Range	T_J	-40 to +150	°C
Operating Supply Voltage	V_{OP}	+4.5 to +40	V
Thermal Resistance from Junction to case	SOP8	20	°C/W
	SOP-8L-EP	15	
	TO263	3.5	
	TO252	10	
Thermal Resistance from Junction to ambient	SOP8	60	°C/W
	SOP-8L-EP	50	
	TO263	25	
	TO252	45	

Note: θ_{JA} is measured with the PCB copper area (need connect to V_{SS} , EP or Tap pins) of approximately 1.5 in² (Multi-layer).

❖ ELECTRICAL CHARACTERISTICS

(Unless otherwise specified, $T_A=25^\circ\text{C}$, $V_{CC}=12\text{V}$ for 3.3V, 5V, adjustable version and $V_{CC}=18\text{V}$ for the 12V version. $I_{OUT} = 0.2\text{A}$)

Characteristics	Symbol	Conditions	Min	Typ	Max	Units
Quiescent Current	I_Q	$V_{FB}=1.5\text{V}$ for Adjustable version force driver off	-	4	8	mA
Feedback voltage	V_{FB}	$I_{OUT} = 0.2\text{A}$ (Adjustable version)	1.230	1.242	1.255	V
Feedback bias current	I_{FB}	$V_{FB}=1.5\text{V}$	-	-10	-50	nA
Output Voltage	V_{OUT}	$I_{OUT} = 0.2\text{A}$ (Fixed version)	5.08	5.15	5.20	V
Shutdown supply Current	I_{SD}	EN pin=5V, $V_{CC}=40\text{V}$	-	100	200	uA
Oscillator frequency	F_{OSC}		40	52	65	KHz
Oscillator frequency of short circuit protect	F_{SCP}	$V_{FB} < 0.4\text{V}$ (Adjustable version) or $V_{OUT} = 0\text{V}$ (Fixed Version)	-	20	-	KHz
Max. Duty Cycle (ON)	DC	$V_{FB} = 0\text{V}$ force driver on	-	100	-	%
Min. Duty Cycle (OFF)		$V_{FB} = 1.5\text{V}$ for Adjustable version force driver off	-	0	-	
Current limit	I_{CL}	Peak current, No outside circuit $V_{FB} = 0\text{V}$ force driver on	2.2	-	-	A
Line Regulation	ΔV_{Line}	$V_{CC} = 7.5\sim 40\text{V}$, $I_{OUT} = 10\text{mA}$	-	0.15	0.5	%
Load Regulation	ΔV_{Load}	$I_{OUT} = 0.2$ to 2A	-	0.1	0.5	%
Saturation voltage	V_{SAT}	$I_{OUT} = 2\text{A}$, No outside circuit $V_{FB} = 0\text{V}$ force driver on	-	1.0	1.2	V

SW pin leakage current SW Pin=0V	I _{SW L}	No outside circuit V _{FB} =1.5V for Adjustable version force driver off	-	-	-200	uA
SW pin leakage current SW pin=-0.8V		V _{CC} =40V force driver off	-	-5	-	mA
EN pin logic input threshold voltage	V _{IL}	Low (regulator ON)	-	1.3	0.6	V
	V _{IH}	High (regulator OFF)	2.0		-	
EN pin logic input current	I _H	V _{EN} =2.5V (OFF)	-	-0.1	-10	uA
EN pin input current	I _L	V _{EN} =0.5V (ON)	-	-0.01	-1	
Thermal shutdown Temp	T _{SD}		-	150	-	°C

❖ **APPLICATION CIRCUIT**

(1) Adjustable Output Voltage Version

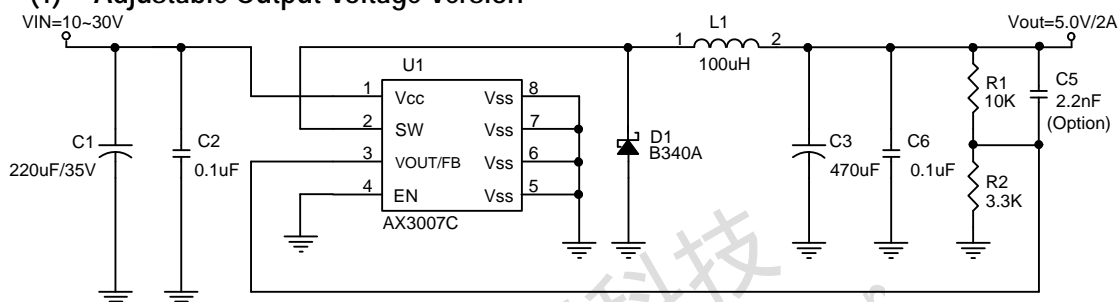

$$V_{OUT} = V_{FB} \times \left(1 + \frac{R1}{R2}\right), V_{FB} = 1.242V, R2 = 1K \sim 3.9K$$

(2) Fixed Output Voltage Version

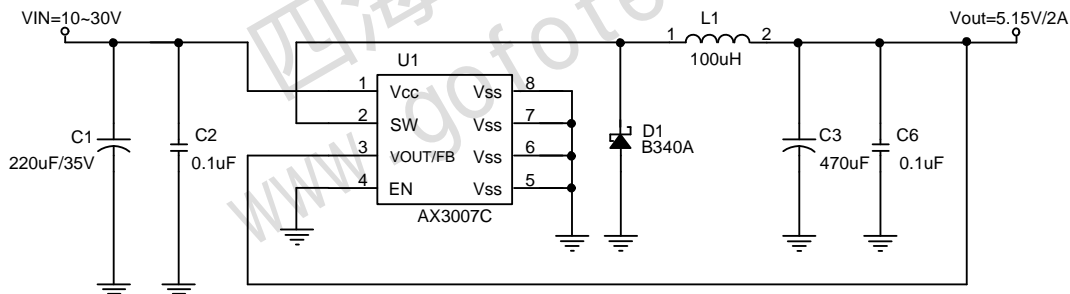

❖ **FUNCTION DESCRIPTION**

Pin Functions

V_{CC}

This is the positive input supply for the IC switching regulator. A suitable input bypass capacitor must be presented at this pin to minimize voltage transients and to supply the switching currents needed by the regulator.

V_{SS}

Circuit ground.

SW

Internal switch. The voltage at this pin switches between $(+V_{CC} - V_{SAT})$ and approximately $-0.5V$, with a duty cycle of approximately V_{OUT} / V_{CC} . To minimize coupling to sensitive circuitry, the PC board copper area connected to this pin should be minimized.

Feedback (adjustable version only)

Sense the regulated output voltage to complete the feedback loop.

EN

Allow the switching regulator circuit to be shutdown using logic level signals thus dropping the total input supply current to approximately 100uA. Pulling this pin below a threshold voltage of approximately 1.3V turns the regulator on, and pulling this pin above 1.3V (up to a maximum of V_{CC}) shuts the regulator down. If this shutdown feature is not needed, the EN pin can be wired to the ground pin.

Thermal Considerations

The SOP-8 package needs a heat sink under most conditions. The size of the heat sink depends on the input voltage, the output voltage, the load current and the ambient temperature. The AX3007C junction temperature rises above ambient temperature for a 2A load and different input and output voltages.

The data for these curves was taken with the AX3007C (SOP-8 package) operating as a buck-switching regulator in an ambient temperature of 25°C (still air). These temperature increments are all approximate and are affected by many factors. Higher ambient temperatures require more heat sinker.

For the best thermal performance, wide copper traces and generous amounts of printed circuit board copper (need connect to the V_{SS} pins) should be used in the board layout, (One exception is the SW(switch) pin, which should not have large areas of copper.) Large areas of copper provide the best transfer of heat (lower thermal resistance) to the surrounding air, and moving air lowers the thermal resistance even further.

Package thermal resistance and junction temperature increments are all approximate. The increments are affected by a lot of factors. Some of these factors include board size, shape, thickness, position, location, and even board temperature. Other factors are, trace width, total printed circuit copper area, copper thickness, single or double-sided, multi-layer board and the amount of solder on the board.

The effectiveness of the PC board to dissipate heat also depends on the size, quantity and spacing of other components on the board, as well as whether the surrounding air is still or moving. Furthermore, some of these components such as the catch diode will add heat to the PC board and the heat can vary as the input voltage changes. For the inductor, depending on the physical size, type of core material and the DC resistance, it could either act as a heat sink taking heat away from the board, or it could add heat to the board.

❖ TYPICAL CHARACTERISTICS

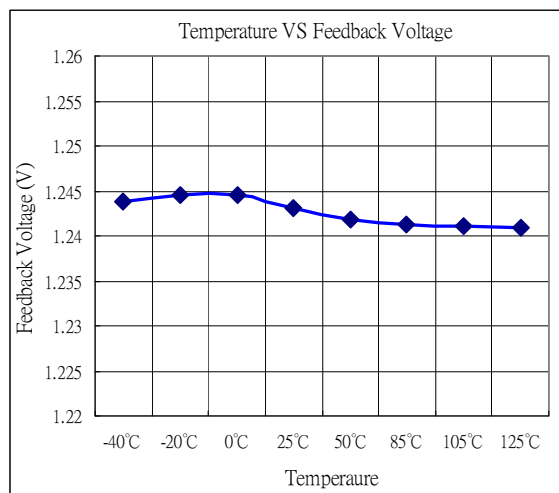
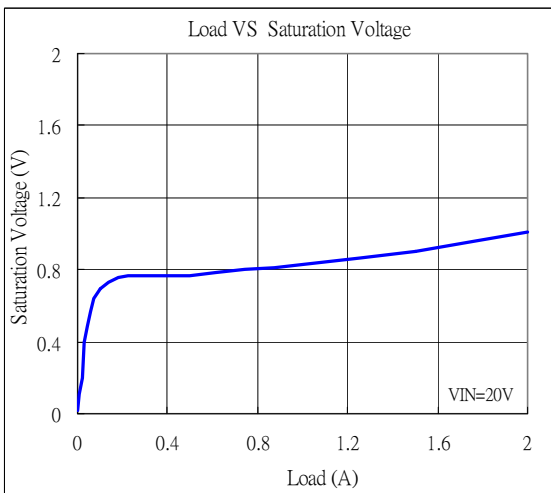
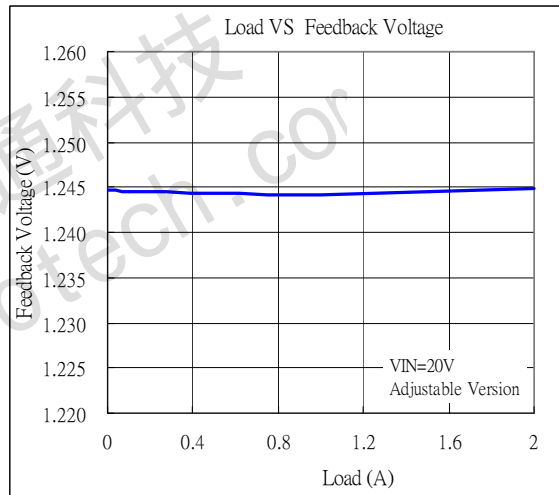
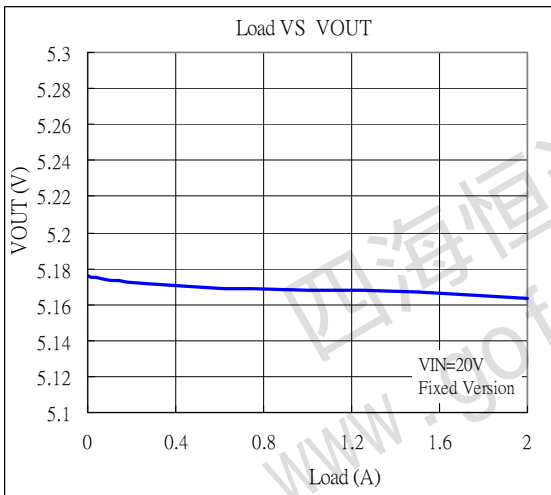
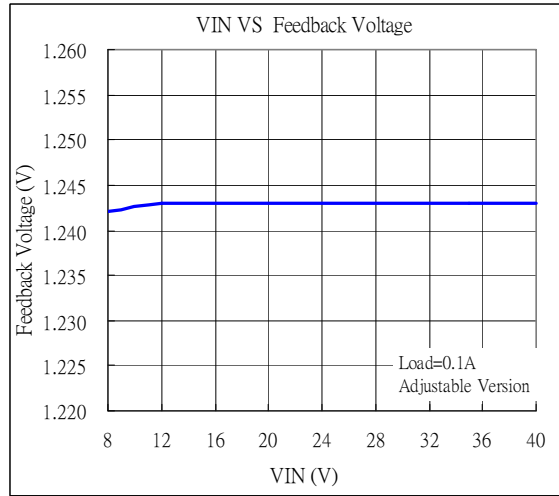
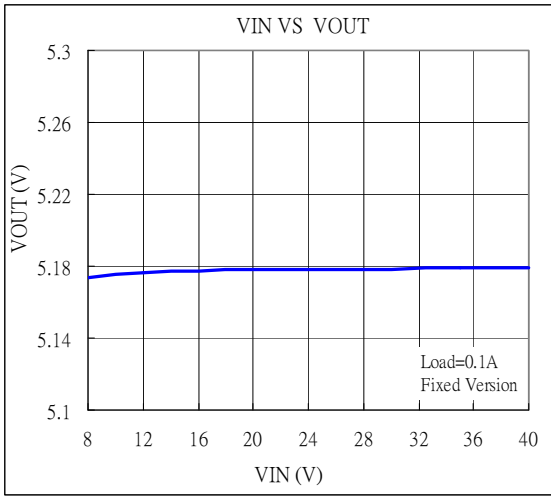

❖ TYPICAL CHARACTERISTICS (CONTINUOUS)

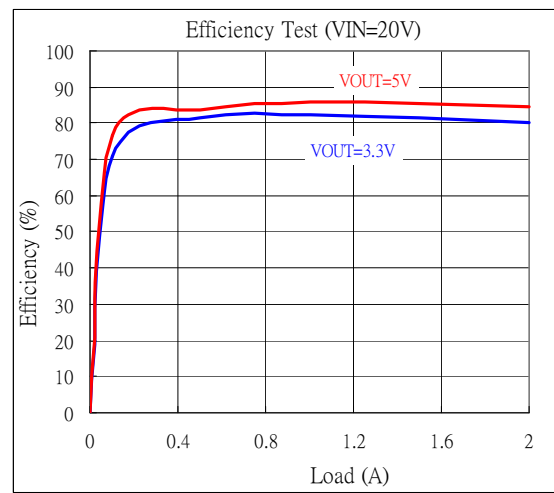
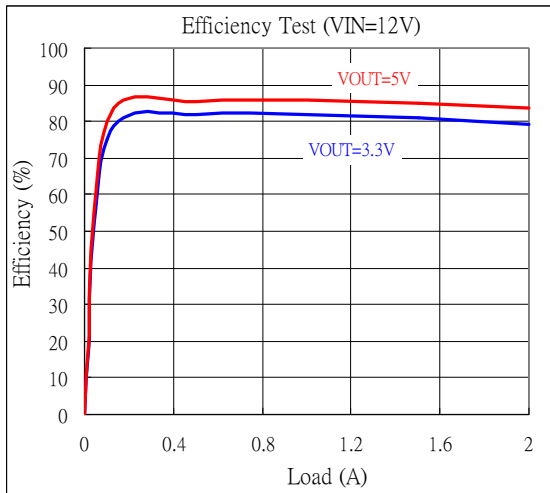

Power on test wave
(VIN=12V, VOUT=5V, IOUT=1A)

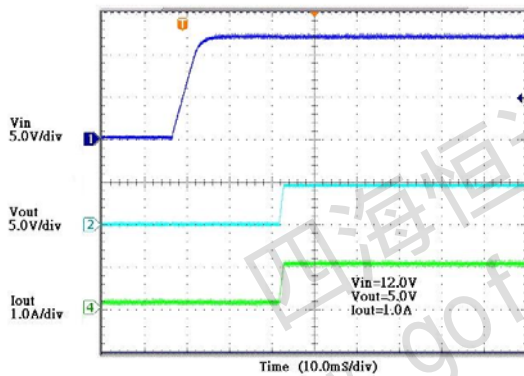

EN on test wave
(VIN=12V, VOUT=5V, IOUT=1A)

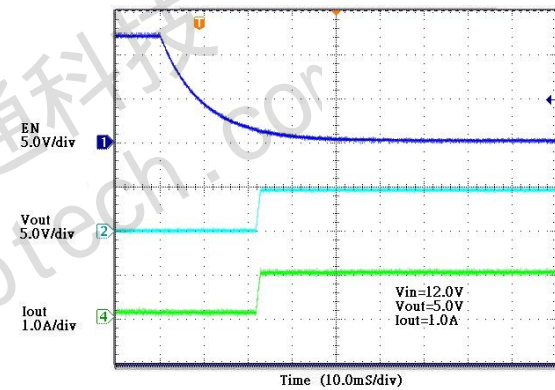

Load Transient Response
(VIN=12V, VOUT=5V, IOUT=0.2~2A)

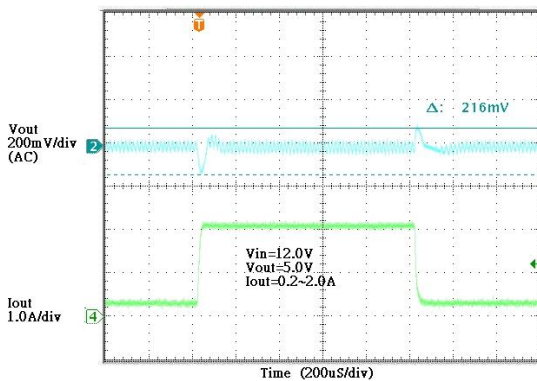

Load Transient Response
(VIN=30V, VOUT=5V, IOUT=0.2~2A)

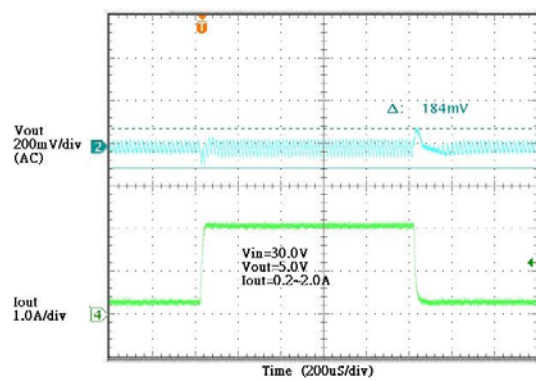

❖ PACKAGE OUTLINES

(1) SOP-8L

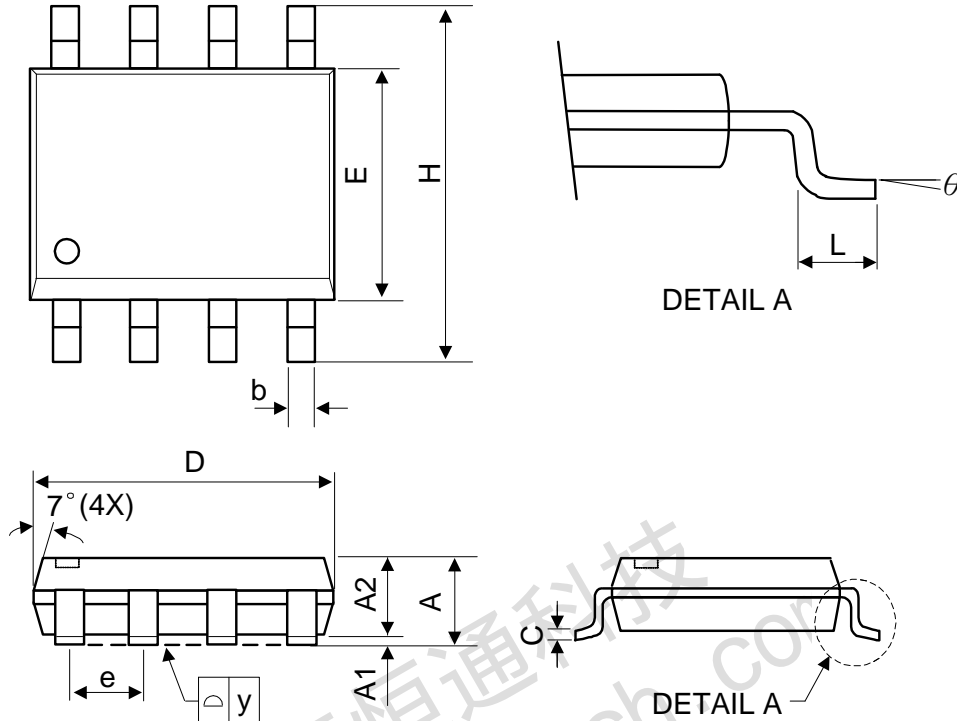

Symbol	Dimensions in Millimeters			Dimensions in Inches		
	Min.	Nom.	Max.	Min.	Nom.	Max.
A	-	-	1.75	-	-	0.069
A1	0.1	-	0.25	0.04	-	0.1
A2	1.25	-	-	0.049	-	-
C	0.1	0.2	0.25	0.0075	0.008	0.01
D	4.7	4.9	5.1	0.185	0.193	0.2
E	3.7	3.9	4.1	0.146	0.154	0.161
H	5.8	6	6.2	0.228	0.236	0.244
L	0.4	-	1.27	0.015	-	0.05
b	0.31	0.41	0.51	0.012	0.016	0.02
e	1.27 BSC			0.050 BSC		
y	-	-	0.1	-	-	0.004
θ	0°	-	8°	0°	-	8°

Mold flash shall not exceed 0.25mm per side

JEDEC outline: MS-012 AA

(2) SOP-8L-EP

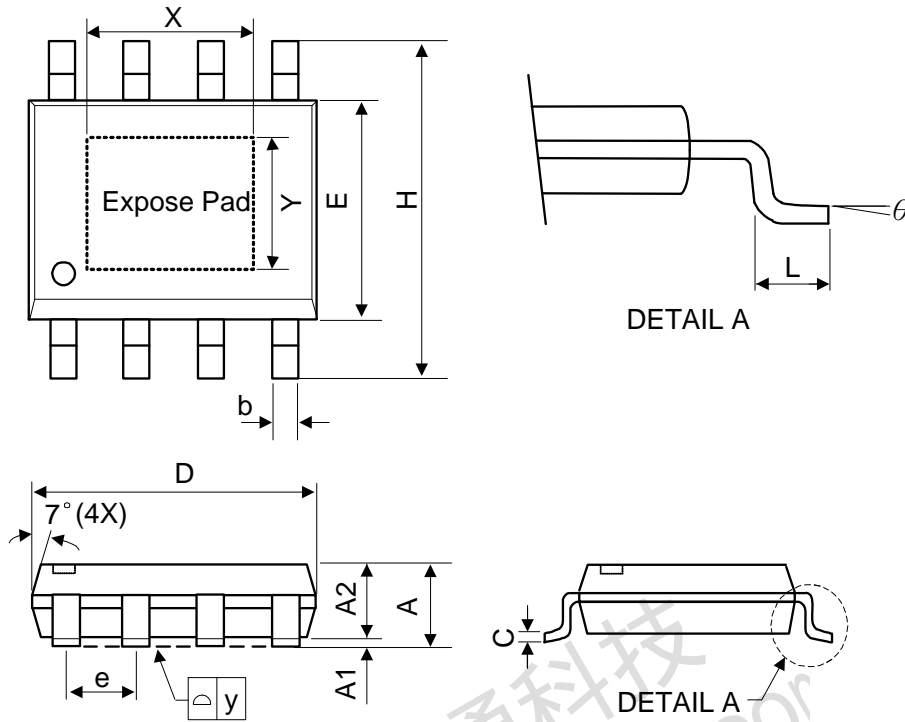

Symbol	Dimensions in Millimeters			Dimensions in Inches		
	Min.	Nom.	Max.	Min.	Nom.	Max.
A	-	-	1.75	-	-	0.069
A1	0	-	0.15	0	-	0.06
A2	1.25	-	-	0.049	-	-
C	0.1	0.2	0.25	0.0075	0.008	0.01
D	4.7	4.9	5.1	0.185	0.193	0.2
E	3.7	3.9	4.1	0.146	0.154	0.161
H	5.8	6	6.2	0.228	0.236	0.244
L	0.4	-	1.27	0.015	-	0.05
b	0.31	0.41	0.51	0.012	0.016	0.02
e	1.27 BSC			0.050 BSC		
y	-	-	0.1	-	-	0.004
X	-	2.34	-	-	0.092	-
Y	-	2.34	-	-	0.092	-
θ	0°	-	8°	0°	-	8°

Mold flash shall not exceed 0.25mm per side
JEDEC outline: MS-012 BA

(3) T0252-5L

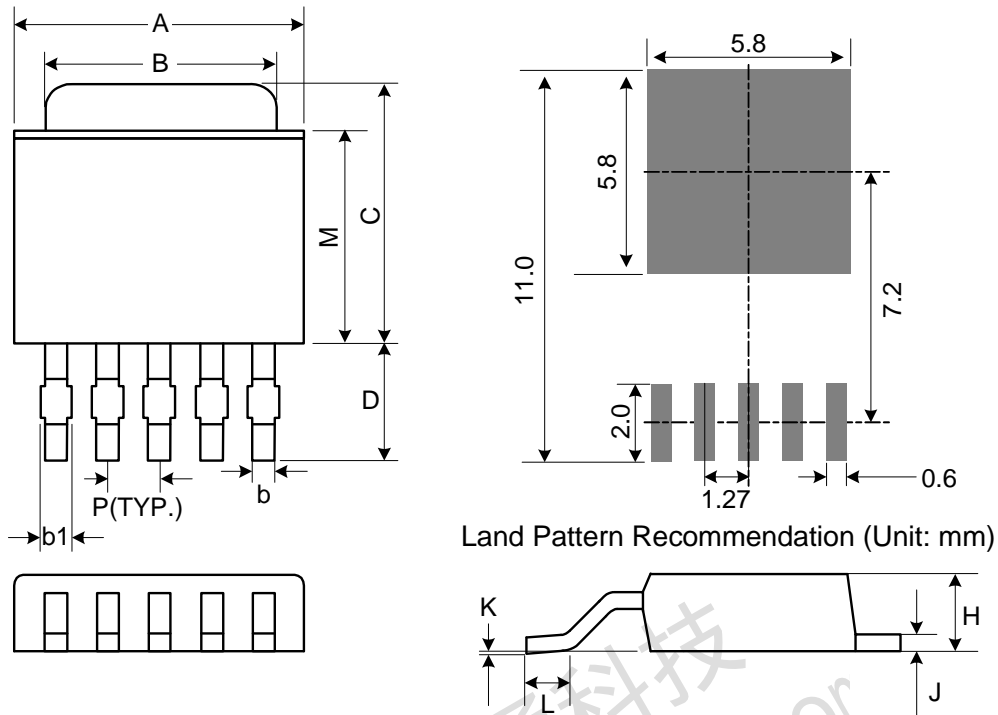

Symbol	Dimensions in Millimeters			Dimensions in Inches		
	Min.	Nom.	Max.	Min.	Nom.	Max.
A	6.35	6.6	6.73	0.250	0.260	0.265
B	5.21	5.33	5.46	0.205	0.210	0.215
C	6.86	7.24	7.62	0.270	0.285	0.300
D	2.67 REF			0.105 REF		
P	1.27 REF			0.050 REF		
H	2.18	2.29	2.39	0.086	0.090	0.094
J	0.46	0.51	0.58	0.018	0.020	0.023
K	0.00	0.08	0.13	0.000	0.003	0.005
L	1.40	1.60	1.78	0.055	0.063	0.070
M	5.33	5.46	5.59	0.210	0.215	0.220
b	0.38	0.56	0.71	0.015	0.022	0.028
b1	0.38	0.53	0.66	0.015	0.021	0.026

Mold flash shall not exceed 0.005inch per side

(4) TO263-5L

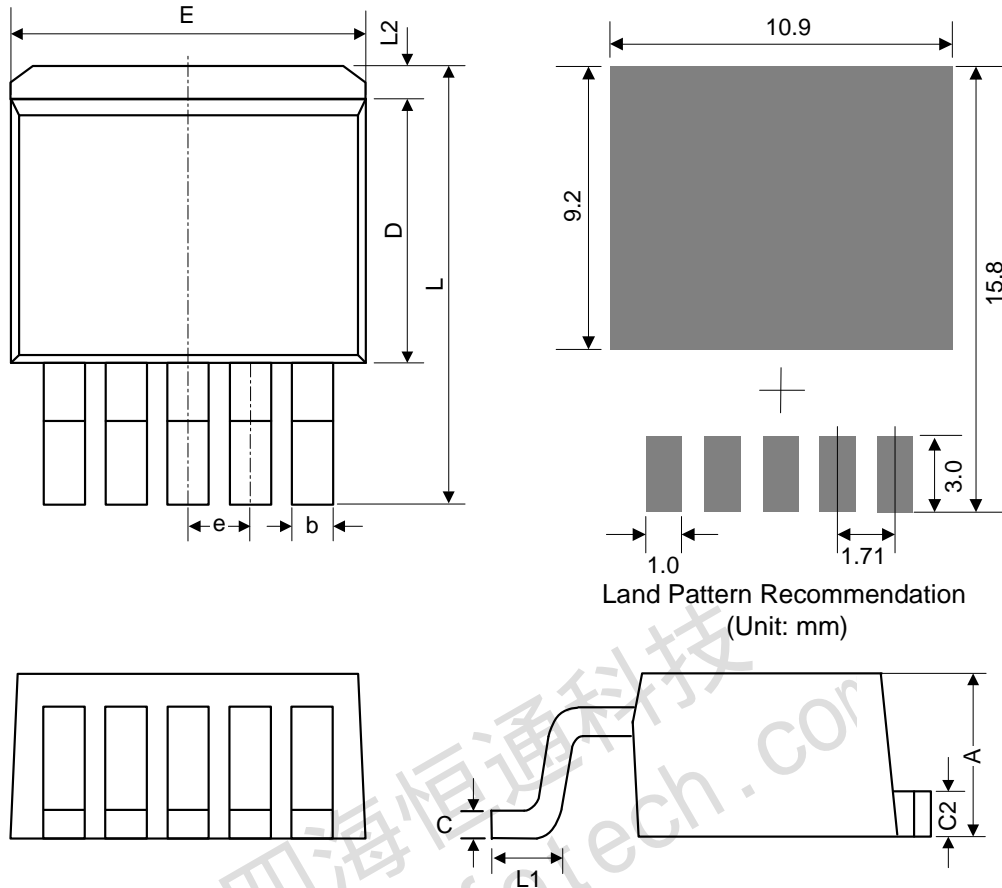

Land Pattern Recommendation
(Unit: mm)

Symbol	Dimensions in Millimeters			Dimensions in Inches		
	Min.	Nom.	Max.	Min.	Nom.	Max.
A	4.06	4.45	4.83	0.16	0.175	0.19
b	0.51	0.76	0.99	0.02	0.03	0.039
C	0.38	0.56	0.74	0.015	0.022	0.029
C2	1.14	1.4	1.65	0.045	0.055	0.065
D	8.38	9.02	9.65	0.33	0.355	0.38
E	9.65	10.2	10.7	0.38	0.4	0.42
e	1.70 BSC			0.067 BSC		
L	14.6	15.2	15.9	0.575	0.6	0.625
L1	1.78	2.29	2.79	0.07	0.09	0.11
L2	-	-	1.68	-	-	0.066

Mold flash shall not exceed 0.005inch per side

JEDEC outline: TO-263 BA