

MICROPOWER VFM SYNCHRONOUS

STEP-UP DC/DC Converter

❖ GENERAL DESCRIPTION

The AX5505 is a high efficiency VFM synchronous Step-up DC/DC converter for small, low input voltage or battery powered systems with ultra-low quiescent supply current. The AX5505 accept a positive input voltage from start-up voltage to V_{OUT} and convert it to a higher output voltage in the 2.1V to 5.0V range.

The AX5505 combine ultra-low quiescent supply current and high efficiency to give maximum battery life. The high switching frequency and the internally limited peak inductor current permits the use of small, low cost inductors. Only three external components are needed an inductor a diode and an output capacitor.

The AX5505 is suitable to be used in battery powered equipment where low noise, low ripple and ultra-low supply current are required. Operating shutdown function is outside controlling. If EN connects to GND, the IC was been shut down and then the supply current is lower to 1uA. The AX5505 is available in very small packages: SOT23-3L, SOT23-5L and SOT89-3L.

Typical applications are pagers, cameras and video camera, cellular telephones, wireless telephones, palmtop computer, battery backup supplies, battery powered equipment.

❖ FEATURES

- Very Low Supply Current is 13uA (typ.)
- Maximum shutdown current <1uA
- Output voltage is available form 2.1V to 5.0V by 0.1V steps
- Output Voltage Accuracy $\pm 2\%$
- No Schottky Diode Required
- Output Current up to 100mA
- Low ripple and low noise
- Very low start-up voltage at 0.8V
- Few external components
- Low profile: SOT23-3L, SOT23-5L and SOT89-3L Pb-Free

❖ BLOCK DIAGRAM

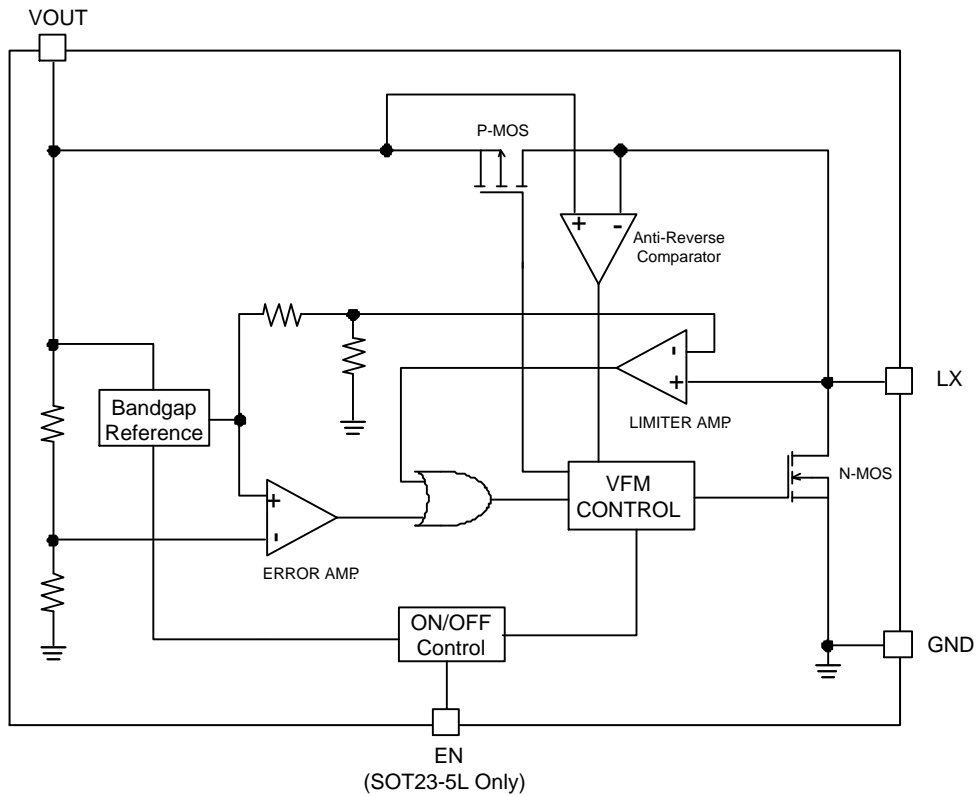

❖ PIN ASSIGNMENT

The packages type: SOT23-3L, SOT23-5L and SOT89-3L; the pin assignment is given by:

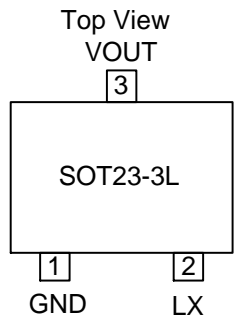
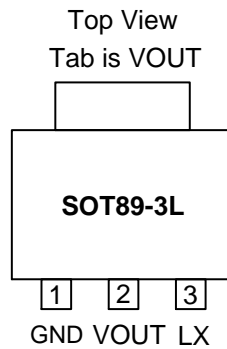
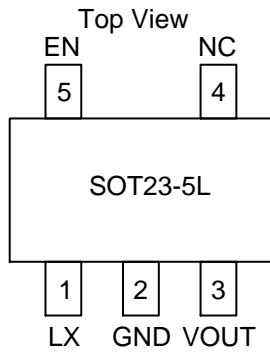

Name	Description
EN	Chip Enable Pin (SOT23-5L Only)
VOUT	Output Voltage Pin
NC	No Connect Pin
GND	Ground Pin
LX	Switch input pin which connected to inductor.

❖ ORDER/MARKING INFORMATION

Order Information	
AX5505 X XX X Package Type V _{OUT} Packing R: SOT23-3L 21 : 2.1V Blank : Bag B: SOT23-5L 22 : 2.2V A : Taping F: SOT89-3L : : 50 : 5.0V	
Top Marking (SOT23-3L/SOT23-5L)	Top Marking (SOT89-3L)

Part Number	Identification Code	Part Number	Identification Code
AX5505-2.1V	WD	AX5505-3.6V	WU
AX5505-2.2V	WE	AX5505-3.7V	WV
AX5505-2.3V	WF	AX5505-3.8V	WW
AX5505-2.4V	WG	AX5505-3.9V	WX
AX5505-2.5V	WH	AX5505-4.0V	WY
AX5505-2.6V	WJ	AX5505-4.1V	WZ
AX5505-2.7V	WK	AX5505-4.2V	Wa
AX5505-2.8V	WL	AX5505-4.3V	Wb
AX5505-2.9V	WM	AX5505-4.4V	Wc
AX5505-3.0V	WN	AX5505-4.5V	Wd
AX5505-3.1V	WP	AX5505-4.6V	We
AX5505-3.2V	WQ	AX5505-4.7V	Wf
AX5505-3.3V	WR	AX5505-4.8V	Wg
AX5505-3.4V	WS	AX5505-4.9V	Wh
AX5505-3.5V	WT	AX5505-5.0V	Wi

❖ ABSOLUTE MAXIMUM RATINGS (at $T_A = 25^\circ\text{C}$)

Characteristics	Symbol	Rating	Unit
V_{IN} Pin Voltage	V_{IN}	5.5	V
LX Voltage	V_{LX}	5.5	V
OUT Pin Voltage	V_{OUT}	5.5	V
EN Pin Voltage	V_{EN}	-0.3 to $V_{OUT}+0.3$	V
Storage Temperature Range	T_{STG}	-40 to +150	$^\circ\text{C}$
Operating Junction Temperature Range	T_J	-20 to +100	$^\circ\text{C}$
Power Dissipation	PD	$(T_J - T_A) / \theta_{JA}$	mW
Thermal Resistance from Junction to case	SOT23-3L	180	$^\circ\text{C/W}$
	SOT23-5L		
	SOT89-3L		
Thermal Resistance from Junction to ambient	SOT23-3L	250	$^\circ\text{C/W}$
	SOT23-5L		
	SOT89-3L		

Note: θ_{JA} is measured with the PCB copper area of approximately 1 in² (Multi-layer).

❖ ELECTRICAL CHARACTERISTICS

($V_{IN} = V_{OUT} \times 0.6$, $I_{OUT}=10\text{mA}$, $T_A = 25^\circ\text{C}$, unless otherwise specified)

Characteristics	Symbol	Conditions	Min	Typ	Max	Units
Output Voltage Accuracy	ΔV_{OUT}		-2	-	+2	%
Start-up Voltage	$V_{START-UP}$	$I_{OUT}=1\text{mA}$ V_{IN} =rising from 0 to 2V	-	0.8	0.95	V
Hold-on Voltage	V_{HOLD}	$I_{OUT}=1\text{mA}$ V_{IN} =falling from 2 to 0V	0.6	-	-	V
Supply Current	I_{SUPPLY}	No Load	-	13	-	μA
Quiescent Current	I_Q	$I_{OUT}=0\text{mA}$, $V_{IN}=V_{OUT} + 0.5\text{V}$	-	6	-	μA
Shutdown Current (SOT23-5L Only)	I_{SD}	$V_{EN}=0\text{V}$	-	-	1	μA
PMOS Switch ON Resistance P- $R_{DS(ON)}$		$I_{LX}=100\text{mA}$	-	1000	-	$\text{m}\Omega$
NMOS Switch ON Resistance N- $R_{DS(ON)}$		$I_{LX}=100\text{mA}$	-	600	-	$\text{m}\Omega$
Maximum Oscillator Frequency	F_{OSC}		-	125	-	KHz
Oscillator Duty On	D_{ON}	To be measure on SW pin	-	77	-	%
Enable Input Threshold (SOT23-5L Only)	V_{ENH}	Driver ON	0.75	-	-	V
	V_{ENL}	Driver OFF	-	-	0.2	
Enable Input Current (SOT23-5L Only)	I_{ENH}	$V_{EN}=V_{IN}$	-	-	0.1	μA
	I_{ENL}	$V_{EN}=0\text{V}$	-	-	1	
Efficiency	η	$V_{IN}=1.5\text{V}$, $V_{OUT}=2.2\text{V}$, $I_{OUT}=10\text{mA}$	-	89	-	%
		$V_{IN}=1.5\text{V}$, $V_{OUT}=3.0\text{V}$, $I_{OUT}=10\text{mA}$	-	87	-	%

❖ APPLICATION CIRCUIT

(1) SOT23-3L/SOT89-3L

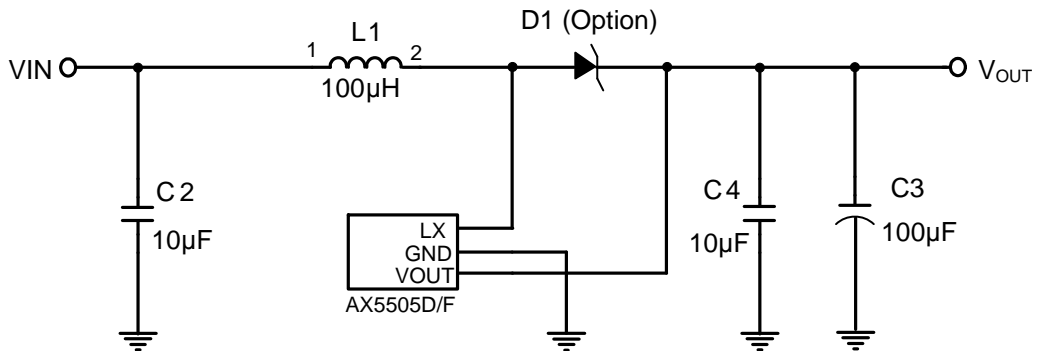

(2) SOT23-5L

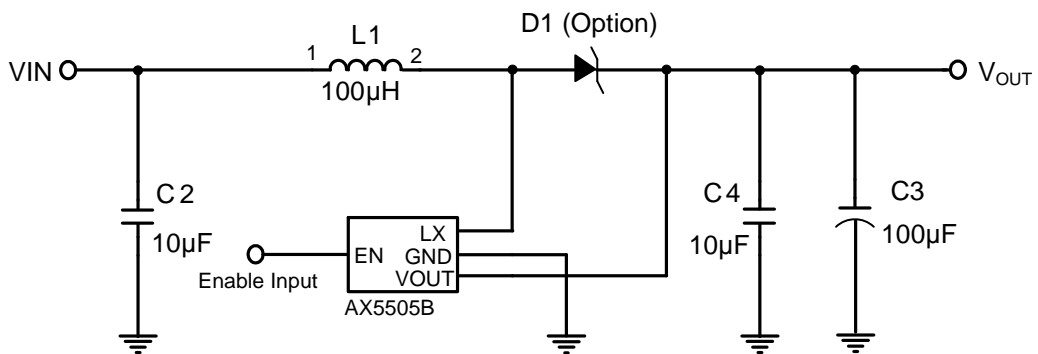

❖ OPERATION

The AX5505 architecture is built around a VFM CONTROL logic core, switching frequency is set through a built in oscillator. T_{ON} time is fixed (Typ. 5µS) while T_{OFF} time is determined by the error amplifier output, a logic signal coming from the comparison made by the Error Amplifier Stage between the signal coming from the output voltage divider network and the internal Band-Gap voltage reference (V_{ref}). T_{OFF} reaches a minimum (Typ. 1.7µS) when heavy load conditions are met (Clock frequency 125KHz). An over current conditions, through the internal power switch, causes a voltage drop $V_{LX} = R_{DS(ON)} \times I_{SW}$ and the V_{LX} limiter block forces the internal switch to be off, so narrowing T_{ON} time and limiting internal power dissipation. In this case the switching frequency may be higher than the 125KHz set by the internal clock generator.

VFM control ensures very low quiescent current and high conversion efficiency even with very light loads. Since the Output Voltage pin is also used as the device Supply Voltage, the versions with higher output voltage present an higher internal supply voltage that results in lower power switch $R_{DS(on)}$, slightly greater output power and higher efficiency. Moreover, bootstrapping allows the input voltage to sag to 0.6V (at $I_{OUT}=1mA$) once the system is started. If the input voltage exceeds the output voltage, the output will follow the input, however, the input or output voltage must not be forced above 5.5V.

❖ APPLICATION INFORMATION

Input/output Capacitor Selection

The Output Ripple Voltage, as well as the Efficiency, is strictly related to the behavior of these elements. The output ripple voltage is the product of the peak inductor current and the output capacitor Equivalent Series Resistance (ESR). Best performances are obtained with good high frequency characteristics capacitors and low ESR. The recommended value of the Output Capacitance is 10 μ F Ceramic Capacitor; Connected a 100 μ F aluminum electrolytic capacitor in V_{OUT} can reduce Output Ripple and improve Efficiency.

An Input Capacitor is required to compensate, if present, the series impedance between the Supply Voltage Source and the Input Voltage of the Application. A ceramic capacitor in 10 μ F is suitable for all application.

Inductor Selection

A 100 μ H inductor is recommended for most AX5505 applications. However, the inductance value is not critical, and the AX5505 will work with inductors in the 82 μ H to 150 μ H.

Diode Option

Need to add diode to improve systematic performance in two kinds of following situations.

1. In the heavily loaded start to reduce start-up voltage.
2. Input voltage close to or exceed the output voltage ($V_{out}-0.5V < V_{IN} < V_{out}+0.5V$) reduces the output voltage ripple.

❖ TYPICAL CHARACTERISTICS

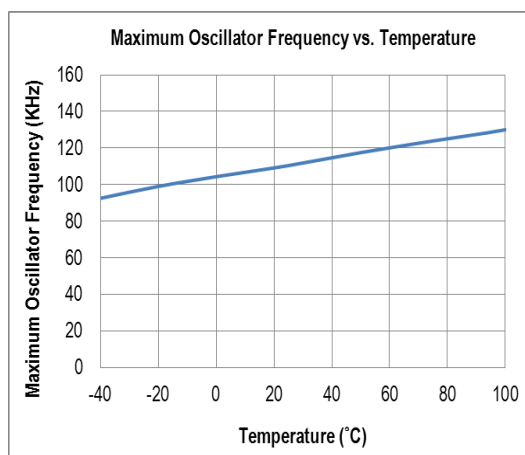
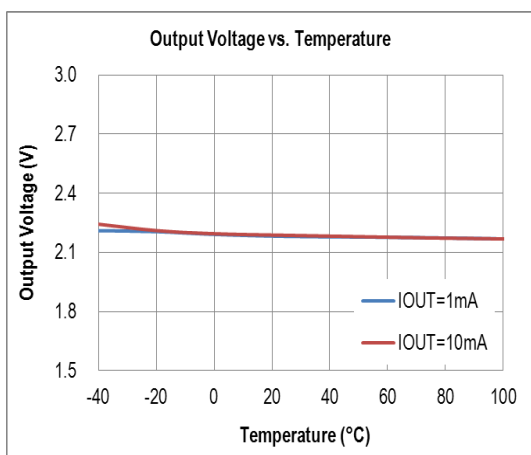
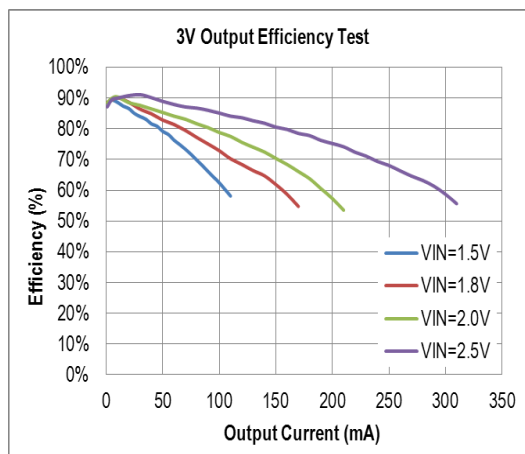
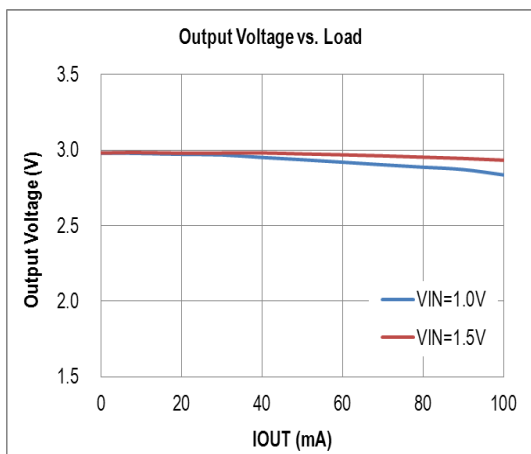
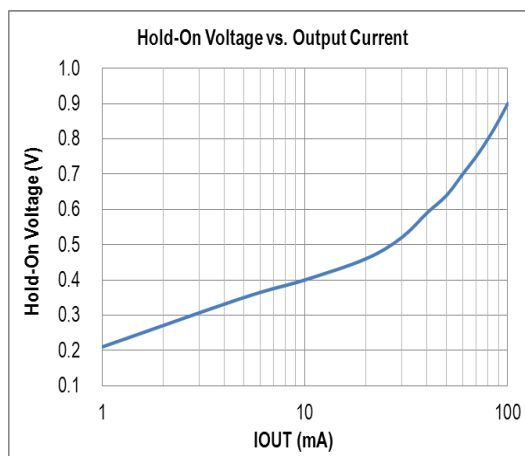
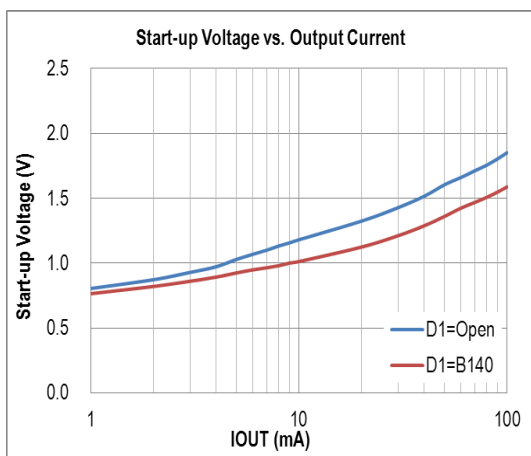

❖ **TYPICAL CHARACTERISTICS (CONTINUOUS)**

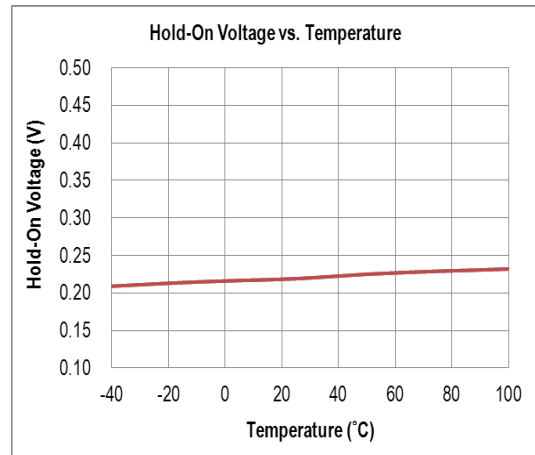
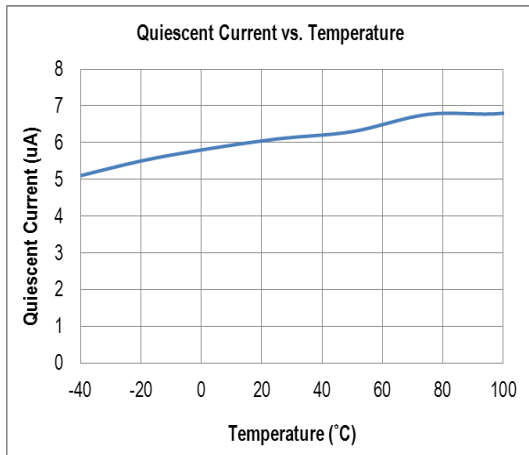
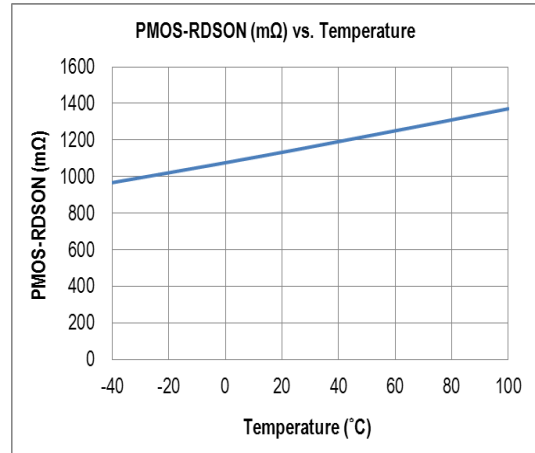
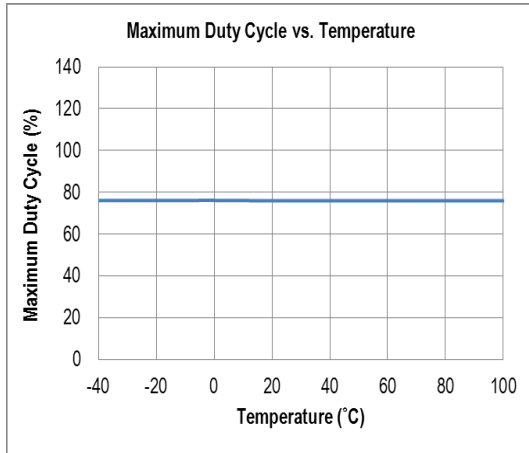

❖ PACKAGE OUTLINES

(1) SOT23-3L

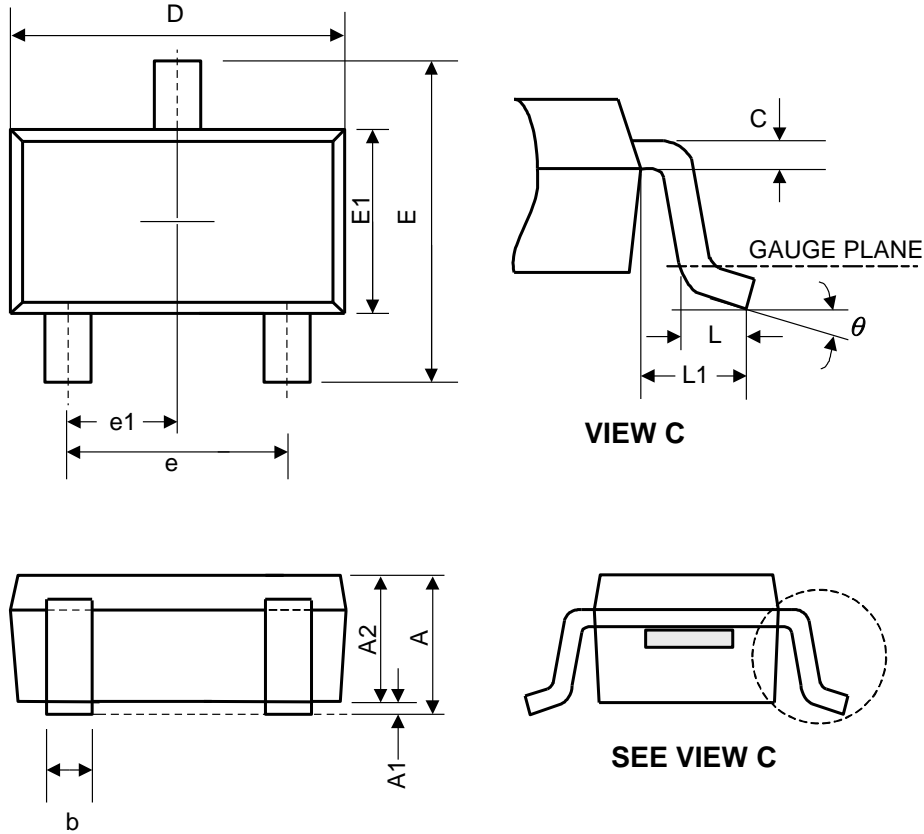

Symbol	Dimensions in Millimeters			Dimensions in Inches		
	Min.	Nom.	Max.	Min.	Nom.	Max.
A	-	-	1.45	-	-	0.057
A1	0.00	0.08	0.15	-	-	0.006
A2	0.90	1.10	1.30	0.035	0.043	0.051
b	0.30	0.40	0.50	0.012	0.016	0.020
C	0.08	0.15	0.22	0.003	0.006	0.009
D	2.70	2.90	3.10	0.106	0.114	0.122
E	2.60	2.80	3.00	0.102	0.110	0.118
E1	1.40	1.60	1.80	0.055	0.063	0.071
L	0.30	0.45	0.60	0.012	0.018	0.024
L1	0.50	0.60	0.70	0.020	0.024	0.028
e	1.9 BSC			0.075 BSC		
e1	0.95 BSC			0.037 BSC		
θ	0°	4°	8°	0°	4°	8°

JEDEC outline: NA

(2) SOT23-5L

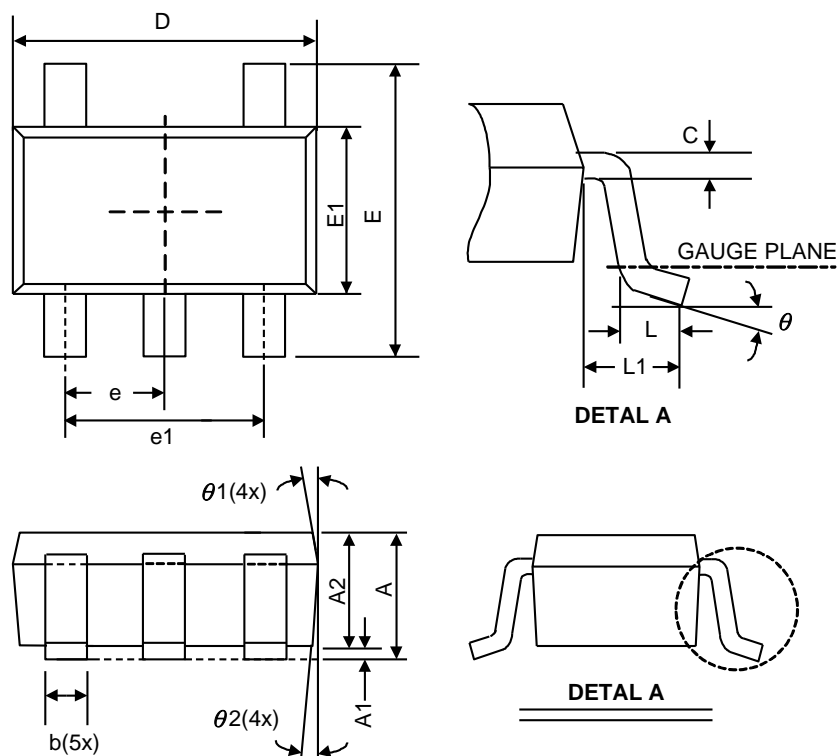

Symbol	Dimensions in Millimeters			Dimensions in Inches		
	Min.	Nom.	Max.	Min.	Nom.	Max.
A	-	-	1.45	-	-	0.057
A1	0.00	0.08	0.15	0	0.003	0.006
A2	0.90	1.10	1.30	0.035	0.043	0.051
b	0.30	0.40	0.50	0.012	0.016	0.020
C	0.08	0.15	0.22	0.003	0.006	0.009
D	2.70	2.90	3.10	0.106	0.114	0.122
E1	1.40	1.60	1.80	0.055	0.063	0.071
E	2.60	2.80	3.00	0.102	0.110	0.118
L	0.30	0.45	0.60	0.012	0.018	0.024
L1	0.50	0.60	0.70	0.020	0.024	0.028
e1	1.9 BSC			0.075 BSC		
e	0.95 BSC			0.037 BSC		
theta	0°	4°	8°	0°	4°	8°
theta 1	5°	10°	15°	5°	10°	15°
theta 2	5°	10°	15°	5°	10°	15°

JEDEC outline: MO-178 AA

(3) SOT89-3L

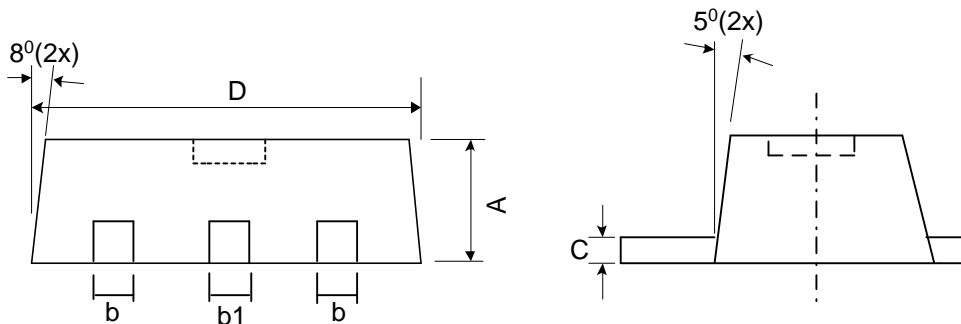
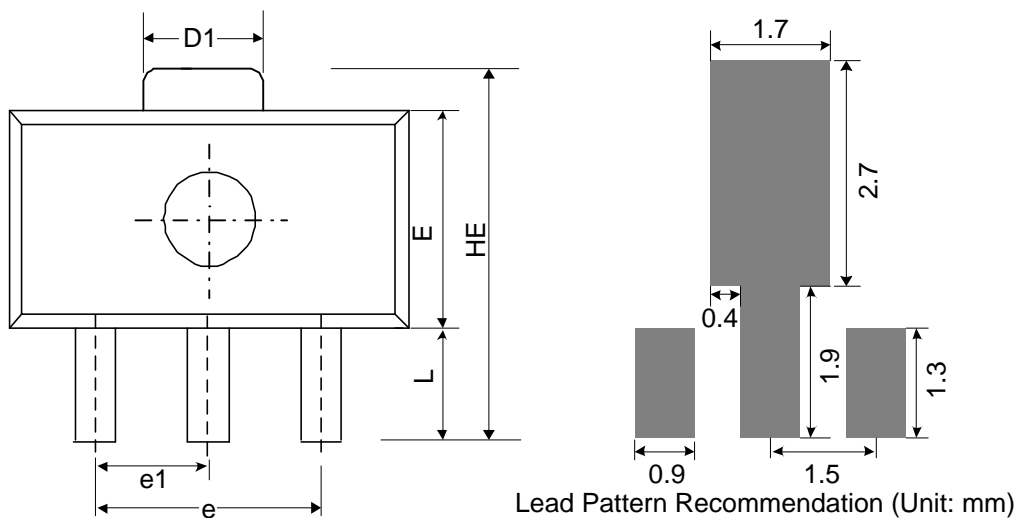

Symbol	Dimensions in Millimeters			Dimensions in Inches		
	Min.	Nom.	Max.	Min.	Nom.	Max.
A	1.40	1.50	1.60	0.055	0.059	0.063
b	0.36	0.42	0.48	0.014	0.017	0.019
b1	0.44	0.50	0.56	0.017	0.02	0.022
C	0.35	0.40	0.44	0.014	0.016	0.017
D	4.40	4.50	4.60	0.173	0.177	0.181
D1	1.35	1.59	1.83	0.053	0.063	0.072
e	3.0 BSC			0.118 BSC		
e1	1.5 BSC			0.059 BSC		
E	2.29	2.45	2.60	0.09	0.097	0.102
HE	3.94	4.10	4.25	0.155	0.161	0.167
L	0.80	1.00	1.20	0.031	0.04	0.047

JEDEC outline: TO-243 AB