

High Performance, Current Mode, Switching **Power Supply Controller**

❖ GENERAL DESCRIPTION

The AX6203 is a high performance, current mode control PWM controller, specific designed for AC/DC transformer with high cost performance ratio. It provides continuous output power 12W and peak output power 18W at the input voltage range 85V~265V. Its optimized and highly reasonable circuit design has made it possible to minimize the total cost of the product. This switching power supply controller could be applied to typical flyback circuit topology to constitute a simple AC/DC converter.

The initial circuit of AX6203 has been designed with a unique current sink method to startup the system by using the magnification function of the switching transistor itself. This will significantly reduce the power consumption of the start-up resistor. While output power becomes smaller, AX6203 will automatically lower the operating frequency to achieve very small standby power consumption. When the switching transistor cuts off, the internal circuit will bias it reversely, it helps to improve the resistant voltage over 700V high voltage of OC pin. This will ensure the safety of the switching transistor.

The AX6203 provides overload and saturation prevention functions, capable of preventing disorders such as overload, transformer saturation and output short circuit, in order to increase the reliability of the power supply. The AX6203 also provides an accurate reference voltage 2.5V for clock generation circuit, and the clock frequency may be set by an external capacitor. Presently, standard PDIP-8L package and environmental friendly lead-free package in compliance with European standard are supplied.

❖ FEATURES

- Built-in 700V high voltage switching transistor, to minimize external components
- Latched PWM and pulse-by-pulse current limit inspection
- Reduced frequency at low output power, standby power consumption below 0.3W
- Built-in slope and feedback compensation function
- Independent the upper limit current inspection controller, real time to handle overload and over current function
- Turn off the periodic bias output of the emitter, to improve the sustaining voltage
- Built-in current limit resistor with temperature compensation to control the current limit accurately
- Built-in thermal protection function
- Complete start-up by using magnification function of switching transistor, to reduce the power consumption of start-up resistor more than ten times
- Automatic VCC over-voltage limit
- Wide continuous output power up to 12W and peak output power up to 18W
- Available in the PDIP-8L Pb-Free Package

❖ BLOCK DIAGRAM

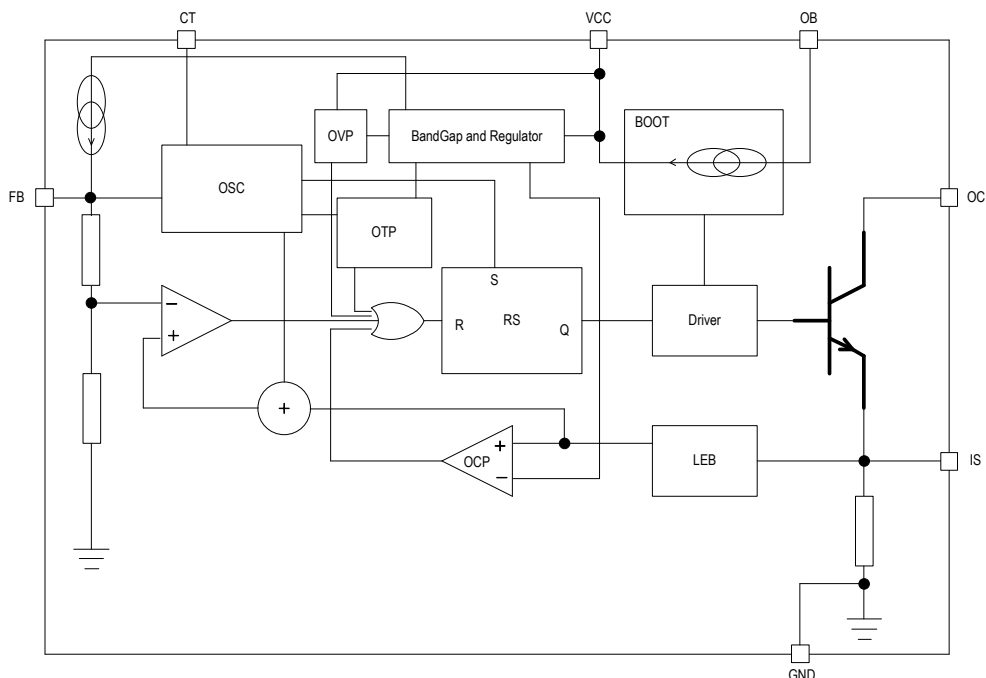

❖ **PIN ASSIGNMENT**

The package of AX6203 is PDIP-8L; the pin assignment is given by:

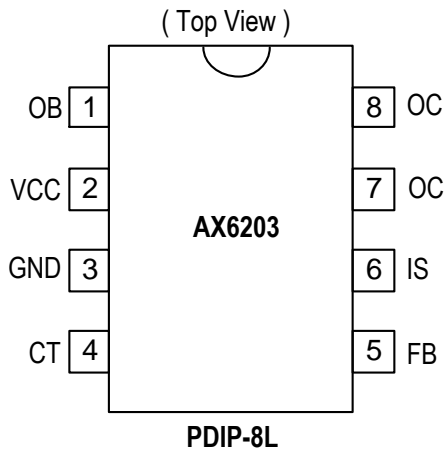

Name	Pin No.	Description
OB	1	Base pin of the switching transistor. (enabling current input and connect to initial resistor)
VCC	2	Power supply pin
GND	3	Ground pin
CT	4	Oscillation capacitance pin. (connect to timing capacitor)
FB	5	Feedback pin
IS	6	Current inspection pin
OC	7, 8	Output pin (connect to switching transformer)

❖ **ORDER/MARKING INFORMATION**

Order Information	Top Marking
<p>AX6203 X X</p> <p>Package Packing N: PDIP-8L Blank : Tube</p>	<p>Logo ← AX 6 2 0 3 → Part number Y Y W W X → ID code:internal WW:01~52 Year: 10=2010 11=2011</p>

❖ **ABSOLUTE MAXIMUM RATINGS** (T_A=25°C)

Characteristics	Symbol	Rating	Unit
Power Supply Voltage	V _{CC}	16	V
Startup Input Voltage		16	V
Pins Input Voltage		V _{CC} +0.3	V
Sustaining Voltage of OC Pin	V _{OC}	-0.3 – 700	V
Switching Current	I _{SW}	800	mA
Total Power Dissipation	P _D	1000	mW
Operating Temperature Range	T _{OP}	0 - +125	°C
Storage Temperature Range	T _{ST}	-55 - +150	°C
Thermal Resistance from Junction to Case	θ _{JC}	15	°C/W
Thermal Resistance from Junction to Ambient	θ _{JA}	50	°C/W

Note: θ_{JA} is measured with the PCB copper area of approximately 1.5 in² (Multi-layer).

❖ ELECTRICAL CHARACTERISTICS

($T_A=25^{\circ}\text{C}$, $V_{CC}=5.5\text{V}$ to 7.5V , $C_T=680\text{pF}$, $R_S=1\Omega$, unless otherwise noted)

Characteristics	Symbol	Conditions	Min	Typ	Max	Units
Output Section						
Sustaining Voltage of Switching Transistor	V_{OC}	$I_{OC}=10\text{mA}$	700	-	-	V
Saturation Voltage	V_{SAT}	$I_{OC}=250\text{mA}$	-	-	1	V
Output Rise Time	T_R	$C_L=1\text{nF}$	-	-	75	ns
Output Fall Time	T_F	$C_L=1\text{nF}$	-	-	75	ns
Output Limiting Current	I_{LIM}	$T_j=0\sim 100^{\circ}\text{C}$	250	270	290	mA
Reference Section						
Reference Output Voltage	V_{REF}	$I_O=1.0\text{mA}$	2.4	2.5	2.6	V
Line Regulation		$V_{CC}=5.5\sim 9\text{V}$	-	2	20	mV
Load Regulation		$I_O=0.1\sim 1.2\text{mA}$	-	-	3	%
Temperature stability			-	0.2	-	mV/ $^{\circ}\text{C}$
Output Noise Voltage		$F=10\text{Hz}\sim 10\text{KHz}$	-	-	50	μV
Long Term Stability		1000hrs@ 85°C	-	5	-	mV
Oscillator Section						
Oscillating Frequency	F_{OSC}	$C_T=680\text{pF}$	56	61	67	KHz
Voltage Stability		$V_{CC}=5.5\sim 9\text{V}$	-	-	1	%
Temperature Stability		$T_A=0\sim 85^{\circ}\text{C}$	-	-	1	%
Oscillator Amplitude (Vp-p)			-	2.2	-	V
Feedback Section						
Input Impedance	Pull-Up Current	$V_{FB}=2.5\text{V}$, $I_S=0\text{V}$	0.55	0.6	0.65	mA
	Pull-Down Resistor		-	30	-	K Ω
Power Supply Suppression Ratio		$V_{CC}=5.5\sim 9\text{V}$	-	60	70	dB
Current Sampling Section						
Current Sampling Threshold	V_{CS}		0.55	0.60	0.65	V
Anti-Upper Limit Current	I_{LIM}		0.25	0.27	0.29	A
Power Supply Suppression Ratio			-	60	70	dB
PWM Section						
Maximum Duty Ratio	D_{MAX}		53	57	61	%
Minimum Duty Ratio	D_{MIN}		-	-	3.5	%

❖ ELECTRICAL CHARACTERISTICS (CONTINUOUS)

Power Supply Current Section						
Initiating Reception Current			1.6	2.4	3.2	mA
Initiating Static Current			-	55	80	uA
Static Current	I_Q	$V_{CC}=8V$	2.8	3.0	3.2	mA
Start-Up Voltage			8.6	8.8	9.0	V
Oscillator Turn-Off Voltage			4.4	4.6	4.8	V
Re-Enabling Voltage			3.6	3.8	4.0	V
Over-Voltage Limit Threshold			9.5	10	10.5	V

Note 1: Stress beyond those listed under absolute maximum ratings may cause permanent damage to the device. Exposure to any absolute maximum rating condition for extended periods may affect device reliability and lifetime.

Note 2: The AX6203 is guaranteed to meet performance specifications from 0°C to 70°C. Specifications over the -40°C to 85°C operating temperature range are assured by design, characterization and correlation with statistical process controls.

❖ APPLICATION CIRCUIT

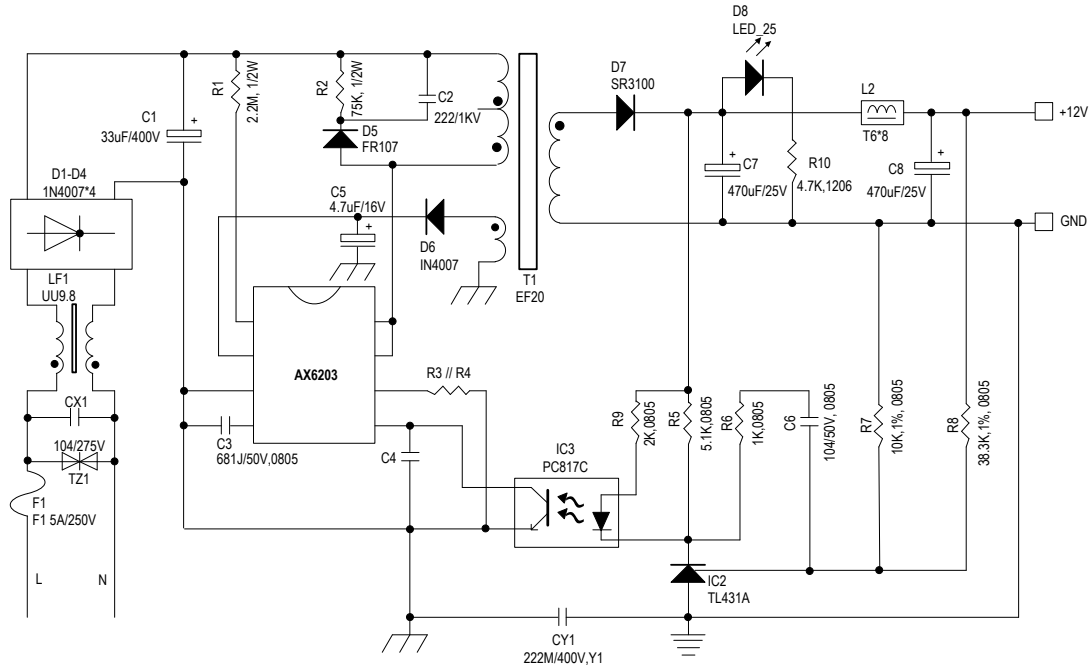

❖ FUNCTION DESCRIPTIONS

During start-up phase, VR is closed when it power on; the FB pull-up current source is closed, OE inputs the start-up current to VCC through transistor, OB controls the base current of transistor and limits the current of transistor collector (namely, AX6203 start-up is initiated by sink current) to secure the transistor. When VCC voltage goes up to 8.8V, the start-up phase is ended, and it comes into the normal operation phase.

During normal phase, VCC voltage shall keep 4.8~9.0V, VR outputs 2.5V benchmark, FB pull-up current source starts up, the oscillator output OSC1 decides the maximum duty ratio, output OSC2 tries to trigger the power to enter the “ON” duty, and shields the peak current of transistor. If FB voltage is less than 1.8V (around 1.2~1.8V), the duty of the oscillator will be increased correspondingly, the lower FB voltage gets wider duty cycle, until the oscillation stops (this characteristic reduces the standby power consumption of the switching power). If the external feedback voltage tries to let VCC more than 9.6V, the internal circuit feedback to FB and makes VCC stabilize at 9.6V (according to this characteristic, we don't apply external feedback circuit, and stabilize output voltage by internal circuit, but the precision is lower).

During the “ON” duty, OB supplies base current for the switching transistor Q1, the switching current flows from OC pin, then passed by Q1 and Q2, finally the current output from IS pin, and OB adopts the ramp current driving (OB current is the parameter of IS voltage, as IS voltage equal 0V, OB current is about 40mA, OB current increases by IS linearly. As IS increases to 0.6V, OB current is about 120mA, this characteristic efficiently uses the OB current, and decreases the power consumption of AX6203). If IS detects the specified current FB, it will come into the “OFF” duty.

During the “OFF” duty, OB pull-down, the transistor will not switch-off immediately, but OE clamps 1.5V (after the transistor is switch-off, the base will be biased reversely, which improves the sustaining voltage). During “ON” or “OFF” cycle, if the transistor is detected beyond the upper limit current, the trigger of upper limit current will be placed preferentially and forces FB to drop, the duty ratio will become less so as to protect the transistor and transformer.

At the beginning of next “OFF” duty or when FB is less than 1.8V, the trigger of the upper limit current will reset. In addition, AX6203 is built-in over temperature protection, when the junction temperature is higher than 140°C, and it will broaden the duty ratio of the oscillator and make the temperature of AX6203 less than 150°C. AX6203 is also built-in ramp compensation, in order to stabilize the ON/OFF duty as big duty ration or continuous current mode.

If VCC drop down to 4.3V or so, the oscillator will turn-off, the output of OSC1 and OSC2 is low, the system keeps at “OFF” duty. When VCC drops down to 3.7V or so, and AX6203 will come into the start-up phase again.

(1) Normal Phase Switching Cycle Oscillogram

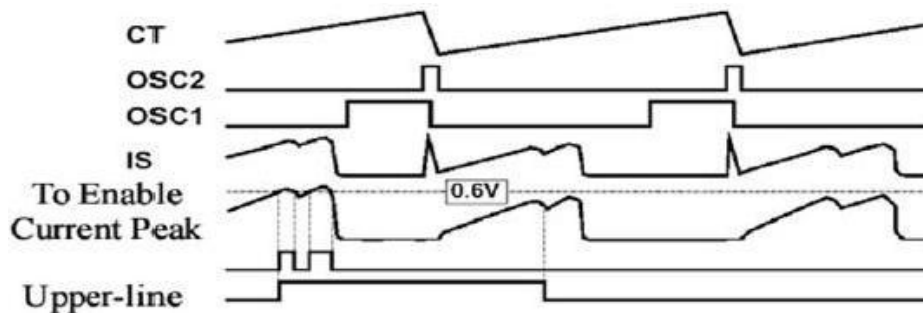

(2) Global Oscillogram

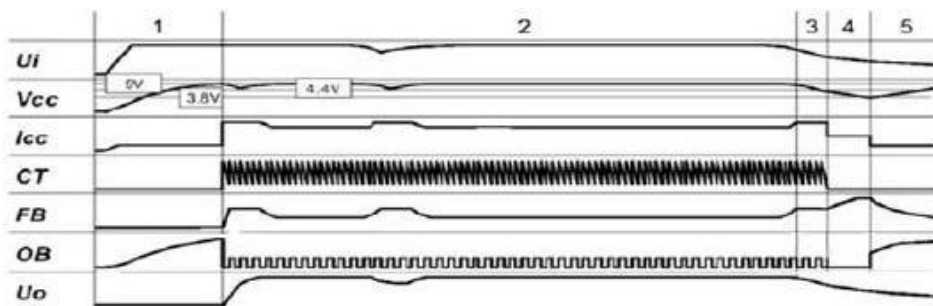

❖ APPLICATION INFORMATION

(1) Electrical Parameter Definitions

- **Start-up receives current:** The current of OC in which OB input current is 0.5mA in start-up phase.
- **Start-up static current:** When VCC is connected the bypass capacitor and adjustable current source, CT is connected a 680pF capacitor, and the rest pins are no connection; the minimum current of adjustable current source which can let VCC complete start-up of AX6203.
- **Start-up voltage:** The maximum VCC in start-up phase.
- **Re-start-up voltage:** The minimum VCC in start-up phase.
- **Oscillator turn-off voltage:** The voltage of VCC as oscillator stops during the VCC falling edge.
- **Static current:** In normal phase, the VCC current when FB is connected 1 K Ω resistor to ground.
- **Oscillator pull-up/pull-down current:** In normal phase, the pull-up/pull-down current of CT when FB=2.5V and CT=1.25V.
- **FB pull-up current:** In normal phase, the pull-up current of FB when FB=2.5V, and IS=0V.
- **FB upper current protection:** In normal phase, the pull-down current of FB when FB=6V and IS=0.3V.
- **Internal feedback voltage:** In normal phase, the VCC voltage when there is no external feedback circuit of AX6203.
- **OC upper limit current:** When FB=6V, the minimum OC current as there is pull-down current in FB.
- **Oscillator cycle:** Which is the function of the capacitor connected to CT, about CT*25400 seconds.

(2) Power Supply Design Points

- Current control switching power supply with flyback design, discontinuous current operation mode.
- The start-up current of power supply is around 0.5~2mA. The magnification of switching transistor Q1 can be supposed as 10. Then the start-up resistance must assure the current of the power transistor's base is between 0.05mA to 0.2mA. Therefore, the power of the output resistance can reduce to 1/10, which reduces the power consumption in idle state.
- In typical application circuit, C3=680pF, the maximum operation frequency is about 67KHz.
- The reference winding rectifier output voltage is around 4.8V~9.0V (6V is recommended) of the switching transformer (T1 in typical application circuit), which provide operation power for AX6203.
- The maximum primary peak current of the switching transformer is 0.6A. When at wide voltage or 110V VAC, or 85V magnetic dissipation voltage, the maximum output power can achieve more than 12W.
- The OC pin of AX6203 is in high voltage, and IS pin connects to a current sense resistor. Therefore, it is easy to open a divider between OC and IS pin to meet the requirement of the safe regulation.
- Although there is over temperature protection, when high power output is needed without considering PCB heat dissipation, the output power and voltage may fall.

❖ PACKAGE OUTLINES

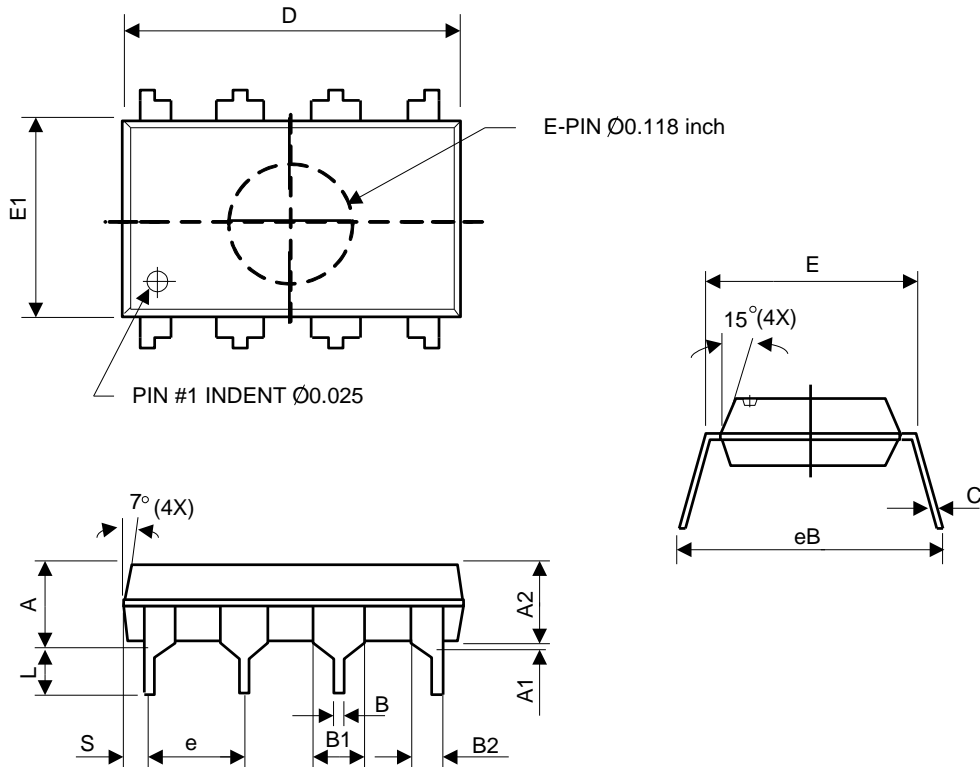

Symbol	Dimensions in millimeters			Dimensions in inches		
	Min.	Nom.	Max.	Min.	Nom.	Max.
A	-	-	5.33	-	-	0.210
A1	0.38			0.015	-	-
A2	2.92	3.30	4.95	0.115	0.130	0.195
B	0.36	0.46	0.51	0.014	0.018	0.020
B1	1.14	1.52	1.78	0.045	0.060	0.070
B2	0.76	0.99	1.14	0.030	0.039	0.045
C	0.20	0.25	0.36	0.008	0.010	0.014
D	9.02	9.27	10.16	0.355	0.365	0.400
E	7.62	7.87	8.26	0.300	0.310	0.325
E1	6.10	6.35	7.11	0.240	0.250	0.280
e	2.54 BSC			0.100 BSC		
L	2.92	3.00	3.81	0.115	0.130	0.150
eB	-	-	10.92	-	-	0.430
S	0.13	-	-	0.005	-	-

JEDEC outline: MO-100 BA