

300mA High PSRR, Low Noise LDO Regulator

❖ GENERAL DESCRIPTION

The AX6603A is a 300mA, low quiescent, high PSRR, low noise and low dropout linear regulator. The Device includes pass element, error amplifier, band-gap, current-limit and thermal shutdown circuitry. The characteristics of low dropout voltage and less quiescent current make it good for some critical current application, for example, some battery powered devices. The typical quiescent current is approximately 90 μ A. In the shutdown mode, the maximum supply current is less than 0.1 μ A. Built-in current-limit, Short current protection and thermal-shutdown functions prevent any fault condition from IC damage.

❖ FEATURES

- Input voltage range : 2.6V~6.0V
- Dropout voltage is 180mV at 150mA output current
- Guaranteed 300mA output current
- Low quiescent current is 90 μ A (typ.)
- Maximum supply current in shutdown mode <0.1 μ A
- 3.3V/2.8V/2.5V/1.8V/1.5V Fixed Output voltage
- High PSRR=70dB@120Hz, 65dB@1KHz
- Fast transient response
- Current limit and thermal shutdown protection
- Short circuit current fold-back
- Available in the 5-Pin Pb-Free SOT-23 Package

❖ BLOCK DIAGRAM

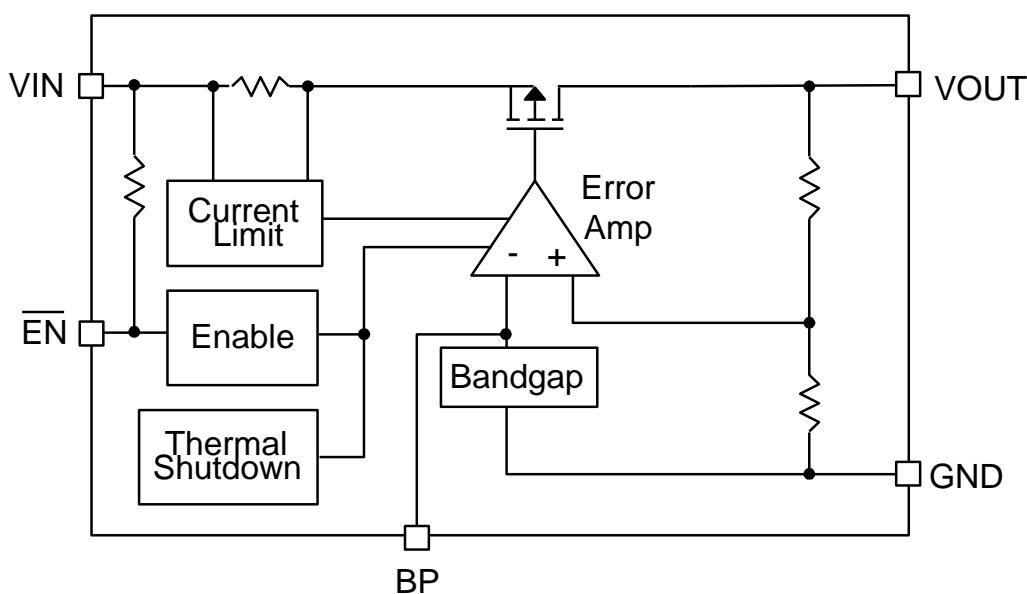

❖ **PIN ASSIGNMENT**

The package of AX6603A is SOT-23-5L; the pin assignment is given by:

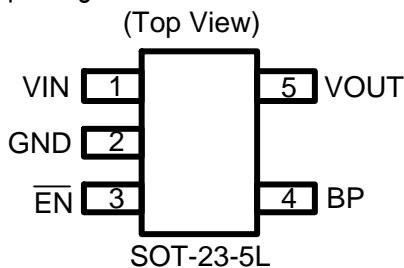

Name	Description
VIN	Voltage input
GND	Ground
EN	Enable pin, it is internal pull high. The pin is pull low enable.
BP	Bandgap
VOUT	Output Voltage

❖ **ORDER/MARKING INFORMATION**

Order Information	Top Marking
<p>AX6603A-XXX X X</p> <p>Output voltage Package Packing</p> <p>150 : 1.5V B : SOT-23-5L Blank: Bag 180 : 1.8V A : Taping 250 : 2.5V 280 : 2.8V 330 : 3.3V</p>	<p>LLYWX → ID code:internal</p> <p>WW:01~26 (A~Z) 27~52 (a~z)</p> <p>Year: A=2010 1=2011</p> <p>Identification code</p>

Appendix

Part Number	Identification Code
AX6603A-1.5V	L6
AX6603A-1.8V	L5
AX6603A-2.5V	L4
AX6603A-2.8V	L3
AX6603A-3.3V	L2

❖ **ABSOLUTE MAXIMUM RATINGS** (at T_A=25°C)

Characteristics	Symbol	Rating	Unit
V _{IN} Pin Voltage	V _{IN}	GND - 0.3 to GND + 6.5	V
Output Voltage	V _{OUT}	GND - 0.3 to V _{IN} + 0.3	V
Enable Voltage	V _{EN}	GND - 0.3 to GND + 6.5	V
Power Dissipation	PD	400	mW
Storage Temperature Range	T _{ST}	-40 to +150	°C
Operating Temperature Range	T _{OP}	-40 to +85	°C
Junction Temperature	T _J	-40 to +125	°C
Thermal Resistance from Junction to case	θ _{JC}	180	°C/W
Thermal Resistance from Junction to ambient	θ _{JA}	250	°C/W

Note: θ_{JA} is measured with the PCB copper area of approximately 1 in²(Multi-layer). That need connect to GND pin.

❖ **ELECTRICAL CHARACTERISTICS** $T_A=25^{\circ}\text{C}$ (unless otherwise noted)

Characteristics	Symbol	Conditions	Min	Typ	Max	Units	
Input Voltage	V_{IN}	(Note1)	2.6	-	6	V	
Output Voltage Accuracy (Note 2)	ΔV_{OUT}	$V_{IN}=V_{OUT}+0.1\text{V to }6\text{V}$ $V_{OUT}\geq 1.80\text{V}, I_{OUT}=1\text{mA}$	-3	-	+3	%	
		$V_{IN}=2.6\text{V to }6\text{V}$ $V_{OUT}=1.5\text{V}, I_{OUT}=1\text{mA}$	-4	-	+4		
Quiescent Current	I_Q	$I_{OUT}=0\text{mA}, V_{IN}=5\text{V}$	-	90	-	μA	
Dropout Voltage	V_{DROP}	$I_{OUT}=300\text{mA}$	$V_{OUT}=1.50\text{V}$	-	1.10	1.3	V
			$V_{OUT}=1.80\text{V}$	-	0.8	1.0	
			$V_{OUT}=2.50\text{V}$	-	0.4	0.6	
			$V_{OUT}=2.80\text{V}$	-	0.38	0.5	
			$V_{OUT}=3.30\text{V}$	-	0.36	0.5	
Current Limit (Note 3)	I_{LIMIT}		400	600	-	mA	
Short Circuit Current	I_{short}	$V_{OUT}<1.0\text{V}$	-	170	-	mA	
Load Regulation (Note 4)	ΔV_{LOAD}	$I_{OUT}=10\text{m}\sim 300\text{mA}$	-	-	0.02	%/mA	
Ripple Rejection	PSRR	$C_{IN}=1\mu\text{F},$ $C_{OUT}=2.2\mu\text{F},$ $I_{OUT}=10\text{mA}$	$F=120\text{Hz}$	-	70	-	dB
			$F=1\text{KHz}$	-	65	-	
Enable Input Threshold	V_{ENH}	Driver OFF	2.0	-	-	V	
	V_{ENL}	Driver ON	-	-	0.8		
Enable Pin Current	I_{EH}	$V_{\overline{EN}}=V_{IN}$	-	0.003	0.1	μA	
Shutdown Current	I_{SD}	$V_{IN}=V_{\overline{EN}}=5\text{V}$	-	-	0.1	μA	
Temperature Shutdown	T_S		-	150	-	$^{\circ}\text{C}$	
Temperature Shutdown Hysteresis	T_{SH}		-	30	-	$^{\circ}\text{C}$	

Note 1: Minimum V_{IN} voltage is defined by output adds a dropout voltage.

Note 2: V_{IN} minimum must larger than 2.6V.

Note 3: Current limit is measured at constant junction temperature by using pulsed testing with a low ON time.

Note 4: Regulation is measured at constant junction temperature by using pulsed testing with a low ON time.

❖ **APPLICATION CIRCUIT**

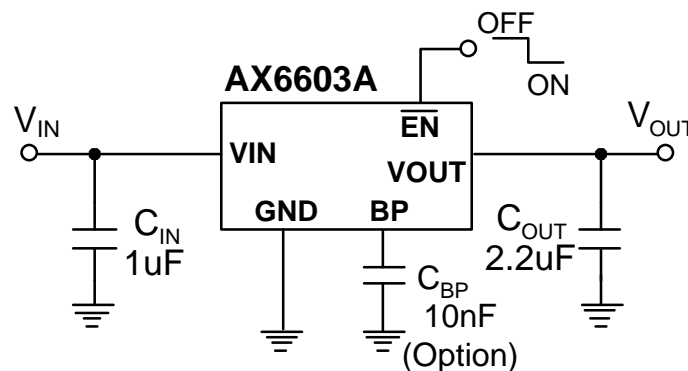

❖ FUNCTION DESCRIPTIONS

A minimum of 2.2μF capacitor must be connected from V_{OUT} to ground to insure stability. Typically a large storage capacitor is connected from V_{IN} to ground to ensure that the input voltage does not sag below the minimum dropout voltage during the load transient response. This pin must always be dropout voltage higher than V_{OUT} in order for the device to regulate properly.

❖ APPLICATION INFORMATION

Like any low-dropout regulator, the AX6603A requires input and output decoupling capacitors. The device is specifically designed for portable applications requiring minimum board space and smallest components. These capacitors must be correctly selected for good performance (see Capacitor Characteristics Section). Please note that linear regulators with a low dropout voltage have high internal loop gains which require care in guarding against oscillation caused by insufficient decoupling capacitance.

Capacitor Selection

Normally, use a 1μF capacitor on the input and a 2.2μF capacitor on the output of the AX6603A. Larger input capacitor values and lower ESR (X5R, X7R) provide better supply-noise rejection and transient response. A higher- value output capacitor (10μF) may be necessary if large, fast transients are anticipated and the device is located several inches from the power source.

Input-Output (Dropout) Voltage

A regulator's minimum input-to-output voltage differential (dropout voltage) determines the lowest usable supply voltage. In battery-powered systems, this determines the useful end-of-life battery voltage. Because the device uses a PMOS, its dropout voltage is a function of drain-to source on-resistance, R_{DS (ON)}, multiplied by the load current:

$$V_{\text{DROPOUT}} = V_{\text{IN}} - V_{\text{OUT}} = R_{\text{DS (ON)}} \times I_{\text{OUT}}$$

Current Limit and Short-Circuit Protection

The AX6603A uses a current sense-resistor to monitor the output current. A portion of the PMOS output transistor's current is mirrored to a resistor such that the voltage across this resistor is proportional to the output current. Once the output current exceeds limit threshold, AX6603A would be protected with a limited output current. Further more, when the output is short to ground, the output current would be folded-back to a less limit.

Thermal Considerations

The AX6603A series can deliver a current of up to 300mA over the full operating junction temperature range. However, the maximum output current must be dated at higher ambient temperature to ensure the junction temperature does not exceed 125°C. With all possible conditions, the junction temperature must be within the range specified under operating conditions. Power dissipation can be calculated based on the output current and the voltage drop across regulator.

$$PD = (V_{IN} - V_{OUT}) I_{OUT}$$

The final operating junction temperature for any set of conditions can be estimated by the following thermal equation:

$$PD (MAX) = (T_{J(MAX)} - T_A) / \theta_{JA}$$

Where $T_{J(MAX)}$ is the maximum junction temperature of the die (125°C) and T_A is the maximum ambient temperature. The junction to ambient thermal resistance (θ_{JA}) for SOT-23-5L package at recommended minimum footprint is 250°C/W. Visit our website in which "Recommended Footprints for Soldering Surface Mount Packages" for detail.

PCB Layout

An input capacitance of $\cong 1\mu F$ is required between the AX6603A input pin and ground (the amount of the capacitance may be increased without limit), this capacitor must be located a distance of not more than 1cm from the input and return to a clean analog ground. Input capacitor can filter out the input voltage spike caused by the surge current due to the inductive effect of the package pin and the printed circuit board's routing wire. Otherwise, the actual voltage at the IN pin may exceed the absolute maximum rating. The output capacitor also must be located a distance of not more than 1cm from output to a clean analog ground. Because it can filter out the output spike caused by the surge current due to the inductive effect of the package pin and the printed circuit board's routing wire.

❖ TYPICAL CHARACTERISTICS

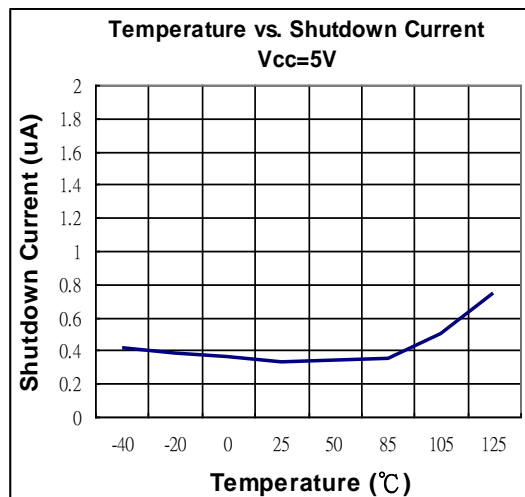
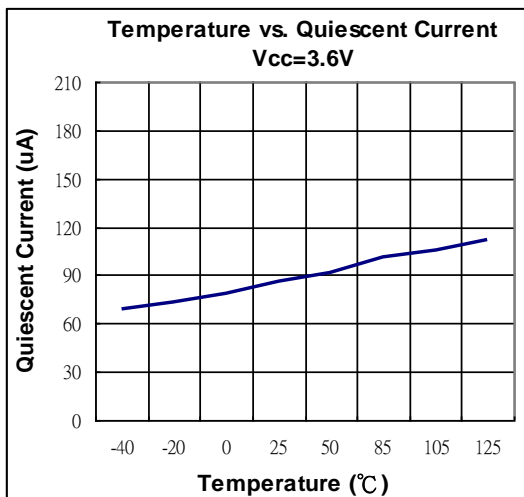
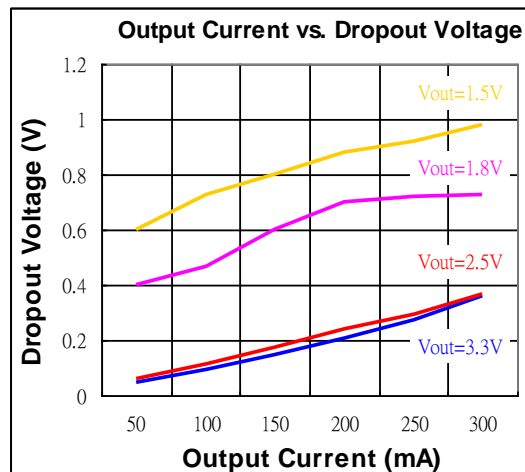
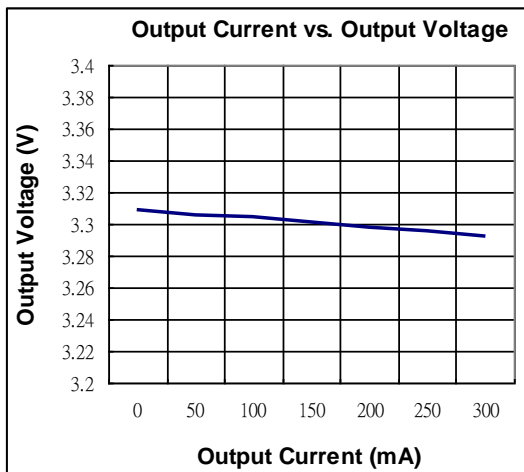
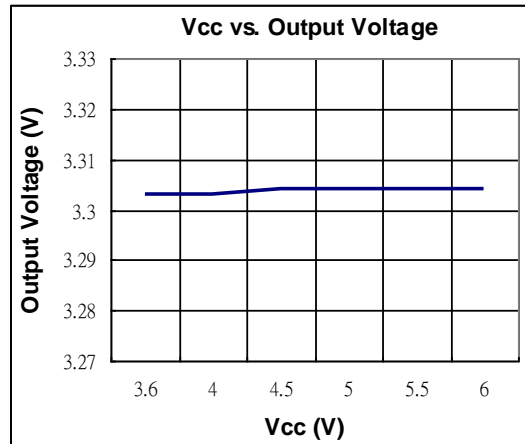
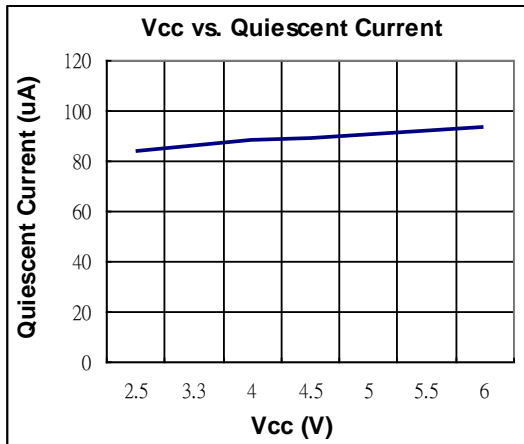

❖ TYPICAL CHARACTERISTICS (CONTINUES)

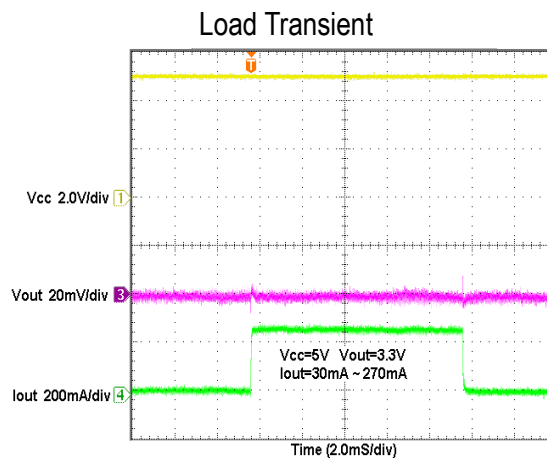
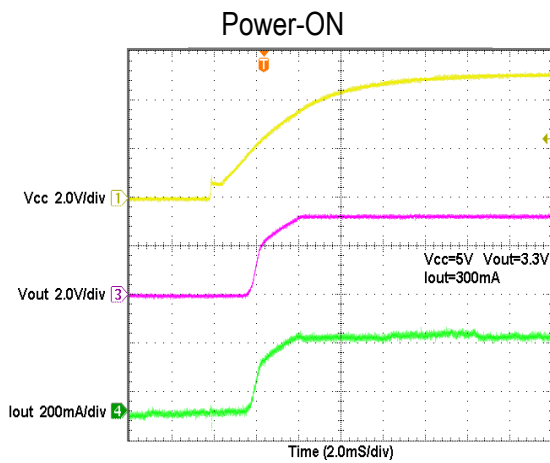
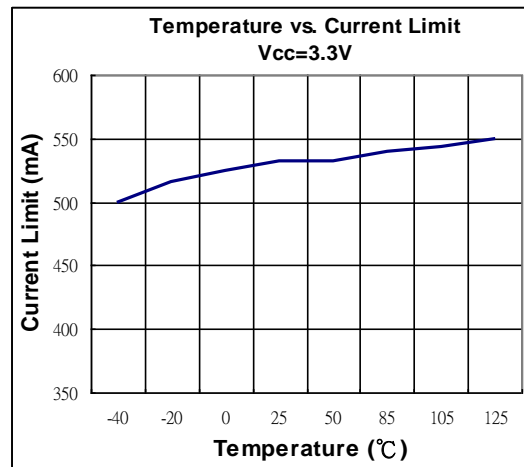
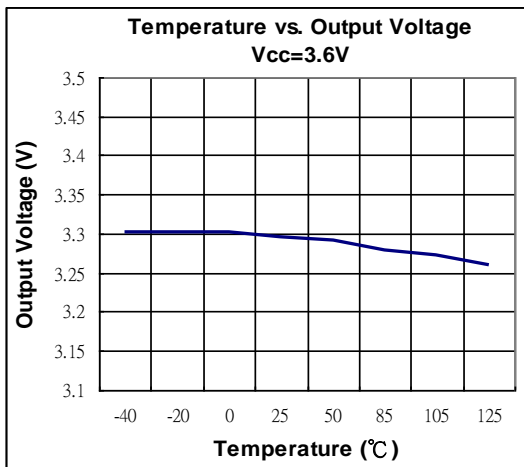

❖ PACKAGE OUTLINES

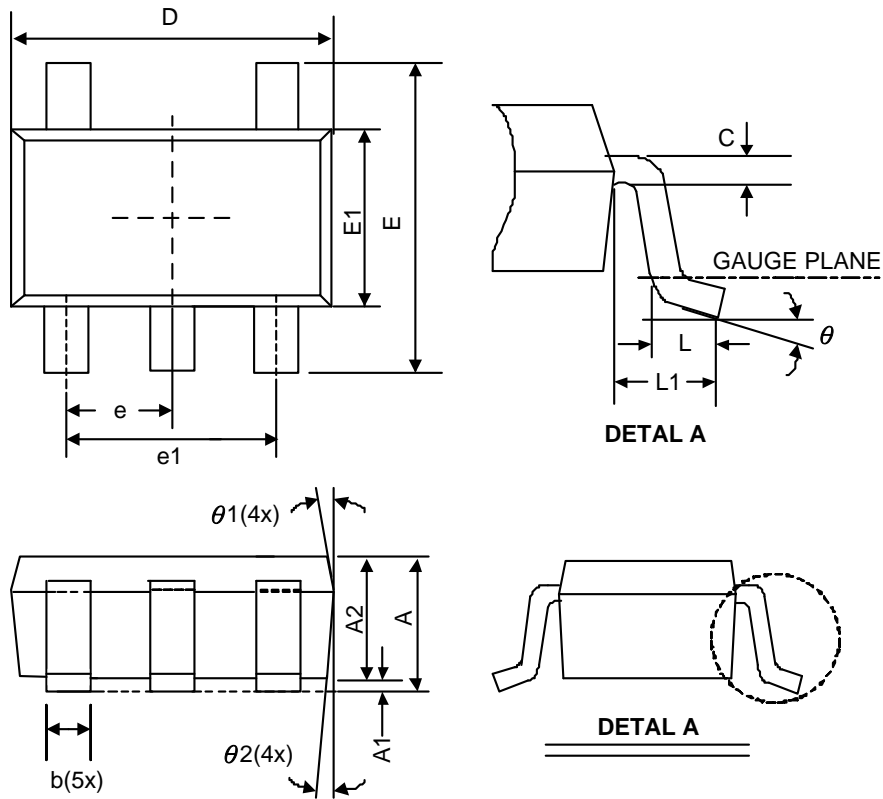

Symbol	Dimensions in Millimeters			Dimensions in Inches		
	Min.	Nom.	Max.	Min.	Nom.	Max.
A	-	-	1.45	-	-	0.057
A1	0	0.08	0.15	0	0.003	0.006
A2	0.9	1.1	1.3	0.035	0.043	0.051
b	0.3	0.4	0.5	0.012	0.016	0.02
C	0.08	0.15	0.22	0.003	0.006	0.009
D	2.7	2.9	3.1	0.106	0.114	0.122
E1	1.4	1.6	1.8	0.055	0.063	0.071
E	2.6	2.8	3	0.102	0.11	0.118
L	0.3	0.45	0.6	0.012	0.018	0.024
L1	0.5	0.6	0.7	0.02	0.024	0.028
e1	1.9 BSC			0.075 BSC		
e	0.95 BSC			0.037 BSC		
θ	0°	4°	8°	0°	4°	8°
$\theta 1$	5°	10°	15°	5°	10°	15°
$\theta 2$	5°	10°	15°	5°	10°	15°

JEDEC outline: MO-178 AA