

5A Ultra Low Dropout Linear Regulator

❖ GENERAL DESCRIPTION

The AX6611 is a 5A ultra low dropout linear regulator. This product is specifically designed to provide well supply voltage for front-side-bus termination on motherboards and NB applications. The IC needs two supply voltages, a control voltage for the circuitry and a main supply voltage for power conversion, to reduce power dissipation and provide extremely low dropout. The AX6611 integrates many functions. A Power-On-Reset (POR) circuit monitors both supply voltages to prevent wrong operations. A thermal shutdown and current limit functions protect the device against thermal and current over-loads. A POK indicates the output status with time delay which is set internally. It can control other converter for power sequence. The AX6611 can be enabled by other power system. Pulling and holding the EN pin below 0.3V shuts off the output.

The AX6611 is available in SOP-8L-EP package which features small size as SOP-8L and an Exposed Pad to reduce the junction-to-case resistance, being applicable in 2~3W applications.

❖ FEATURES

- Ultra Low Dropout - 0.22V(typical) at 5A Output Current
- Low ESR Output Capacitor (Multi-layer Chip Capacitors (MLCC)) Applicable
- 0.8V Reference Voltage
- Fast Transient Response
- Adjustable Output Voltage by External Resistors
- Power-On-Reset Monitoring on Both V_{CNTL} and V_{IN} Pins
- Internal Soft-Start
- Under-Voltage Protection
- Current-Limit and Thermal Shutdown Protection
- Power-OK Output with a Delay Time
- SOP-8L with Exposed Pad Pb-Free Package.

❖ ABSOLUTE MAXIMUM RATINGS (at $T_A=25\text{ }^\circ\text{C}$)

Characteristics	Symbol	Rating	Unit
V_{CNTL} Supply Voltage	V_{CNTL}	-0.3 to 7	V
V_{IN} Supply Voltage	V_{IN}	-0.3 to 6	V
EN and FB Pin Voltage	$V_{\text{I/O}}$	-0.3 to $V_{\text{CNTL}}+0.3$	V
Power good Voltage	V_{POK}	-0.3 to 7	V
Power Dissipation	PD	3	W
Storage Temperature Range	T_{ST}	-65 to +150	$^\circ\text{C}$
Junction Temperature Range	T_{J}	-40 to 125	$^\circ\text{C}$
Operating Temperature Range	T_{OP}	-40 to +85	$^\circ\text{C}$
Thermal Resistance from Junction to case	θ_{JC}	15	$^\circ\text{C/W}$
Thermal Resistance from Junction to ambient	θ_{JA}	40	$^\circ\text{C/W}$

Note: θ_{JA} is measured with the PCB copper area (need connect to Expose-Pad) of approximately 1.5 in² (Multi-layer)

❖ RECOMMENDED OPERATING CONDITIONS

Characteristics	Symbol	Conditions	Rating	Unit
V_{CNTL} Supply Voltage	V_{CNTL}		3.1 to 6	V
V_{IN} Supply Voltage	V_{IN}		1.1 to 5	V
Output Voltage	V_{OUT}	$V_{\text{CNTL}}=3.3\text{V}$	0.8 to 1.2	V
		$V_{\text{CNTL}}=5\text{V}$	0.8 to 3.3	V
Output Current	I_{OUT}		0 to 5	V

❖ ELECTRICAL CHARACTERISTICS

($V_{\text{CNTL}} = 5\text{V}$, $V_{\text{IN}} = 1.5\text{V}$, $V_{\text{OUT}} = 1.2\text{V}$, $T_A=25\text{ }^\circ\text{C}$ unless otherwise specified)

Characteristics	Symbol	Conditions	Min	Typ	Max	Units
V_{CNTL} POR Threshold	V_{CNTL}		2.7	2.9	3.1	V
V_{CNTL} POR Hysteresis	$V_{\text{CNTL(hys)}}$		-	0.4	-	V
V_{IN} POR Threshold	V_{IN}		0.8	0.9	1.0	V
V_{IN} POR Hysteresis	$V_{\text{IN(hys)}}$		-	0.5	-	V
V_{CNTL} Nominal Supply Current	I_{CNTL}	EN= V_{CNTL}	0.4	1	2	mA
V_{CNTL} Shutdown Current	I_{SD}	EN= 0V	-	18	30	μA
Feedback Voltage	V_{FB}	$V_{\text{CNTL}}=3.3 \sim 5\text{V}$	0.784	0.8	0.816	V
Load Regulation		$I_{\text{OUT}}=0\text{A} \sim 5\text{A}$	-	0.06	0.25	%
Dropout Voltage	V_{DROP}	$I_{\text{OUT}} = 5\text{A}$, $V_{\text{CNTL}}=5\text{V}$, $T_{\text{J}} = -40 \sim 125\text{ }^\circ\text{C}$	-	0.22	0.3	V
Soft Start Time	T_{SS}		-	1	-	mS
EN Pin Logic High threshold voltage	V_{ENH}	Enable	1.2	-	-	V
	V_{ENL}	Disable	-	-	0.4	
EN Hysteresis			-	30	-	mV
EN Pin Pull-Up Current	I_{EN}	EN=GND	-	10	-	μA

❖ ELECTRICAL CHARACTERISTICS (CONTINUES)

Characteristics	Symbol	Conditions	Min	Typ	Max	Units
Current Limit	I_{LIM}	$V_{CNTL}=3.3\sim 5V$, $T_J=-40\sim 125\text{ }^\circ\text{C}$	5.5	-	-	A
Under-Voltage Threshold		VFB Falling	-	0.4	-	V
POK Threshold Voltage for Power OK	V_{POK}	VFB Rising	89%	92%	95%	VFB
POK Threshold Voltage for Power Not OK	V_{PNOK}	VFB Falling	78%	81%	84%	VFB
POK Low Voltage		POK sinks 5mA	-	0.25	0.4	V
POK Delay Time	T_{DELAY}		0.8	2	10	mS
Thermal shutdown Temp	T_{SD}		-	150	-	$^\circ\text{C}$
Thermal Shutdown Hysteresis	T_{SH}		-	50	-	$^\circ\text{C}$

❖ APPLICATION CIRCUIT

1. Using an Output Capacitor with $ESR \geq 20m\Omega$

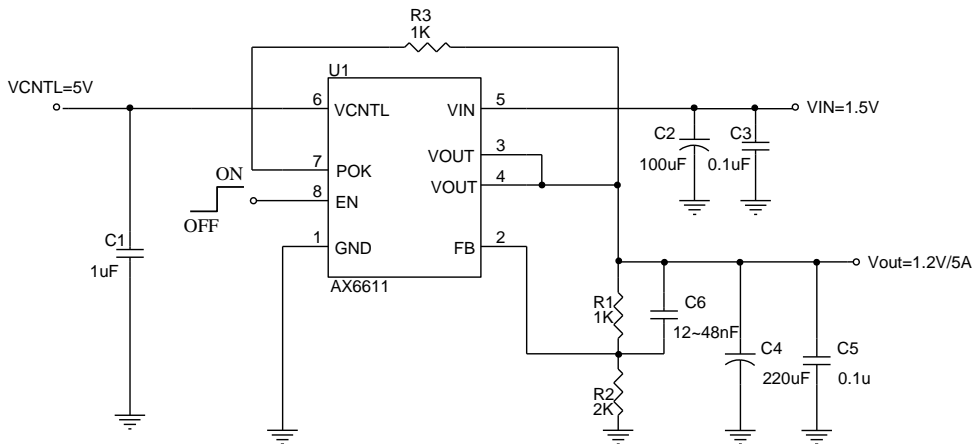

2. Using an MLCC as the Output Capacitor

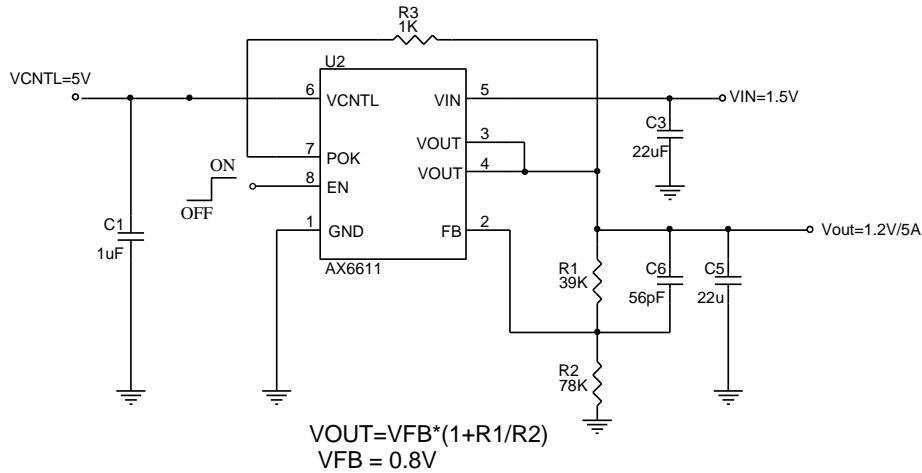

❖ FUNCTION PIN DESCRIPTIONS

FB

Connecting this pin to an external resistor divider receives the feedback voltage of the regulator. The output voltage set by the resistor divider is determined by:

$$V_{OUT} = 0.8 \cdot \left(1 + \frac{R1}{R2} \right) \quad (V)$$

Where R1 is connected from VOUT to FB with Kelvin sensing and R2 is connected from FB to GND. A bypass capacitor may be connected with R1 in parallel to improve load transient response. The recommended R2 and R1 are in the range of 1K~100kΩ.

VIN and Exposed Pad

Main supply input pins for power conversions. The Exposed Pad provides a very low impedance input path for the main supply voltage. Please tie the Exposed Pad and VIN Pin (Pin 8) together to reduce the dropout voltage. The voltage at this pin is monitored for Power-On Reset purpose.

VCNTL

Power input pin of the control circuitry. Connecting this pin to a +5V (recommended) supply voltage provides the bias for the control circuitry. The voltage at this pin is monitored for Power-On Reset purpose.

POK

Power-OK signal output pin. This pin is an open-drain output used to indicate status of output voltage by sensing FB voltage. This pin is pulled low when the rising FB voltage is not above the VPOK threshold or the falling FB voltage is below the VPOK threshold, indicating the output is not OK.

EN

Enable control pin. Pulling and holding this pin below 0.3V shuts down the output. When re-enabled, the IC undergoes a new soft-start cycle. Left this pin open, this pin is internal pulled up to VCNTL voltage, enabling the regulator.

VOUT

Output of the regulator. Please connect Pin 3 and 4 together using wide tracks. It is necessary to connect an output capacitor with this pin for closed-loop compensation and improving transient responses.

❖ FUNCTION DESCRIPTIONS

Power-On-Reset

A Power-On-Reset (POR) circuit monitors both input voltages at VCNTL and VIN pins to prevent wrong logic controls. The POR function initiates a soft-start process after the two supply voltages exceed their rising POR threshold voltages during powering on. The POR function also pulls low the POK pin regardless the output voltage when the VCNTL voltage falls below its falling POR threshold.

Internal Soft-Start

An internal soft-start function controls rise rate of the output voltage to limit the current surge at start-up. The typical soft-start interval is about 1mS.

Output Voltage Regulation

An error amplifier working with a temperature compensated 0.8V reference and an output NMOS regulates output to the preset voltage. The error amplifier designed with high bandwidth and DC gain provides very fast transient response and less load regulation. It compares the reference with the feedback voltage and amplifies the difference to drive the output NMOS which provides load current from VIN to VOUT.

Current-Limit

The AX6611 monitors the current via the output NMOS and limits the maximum current to prevent load and AX6611 from damages during overload or short circuit conditions.

Under-Voltage Protection (UVP)

The AX6611 monitors the voltage on FB pin after soft-start process is finished. Therefore the UVP is disabling during soft-start. When the voltage on FB pin falls below the under-voltage threshold, the UVP circuit shuts off the output immediately. After a while, the AX6611 starts a new soft-start to regulate output.

Thermal Shutdown

A thermal shutdown circuit limits the junction temperature of AX6611. When the junction temperature exceeds +150°C, a thermal sensor turns off the output NMOS, allowing the device to cool down. The regulator regulates the output again through initiation of a new soft-start cycle after the junction temperature cools by 50°C, resulting in a pulsed output during continuous thermal overload conditions. The thermal shutdown designed

❖ TYPICAL CHARACTERISTICS

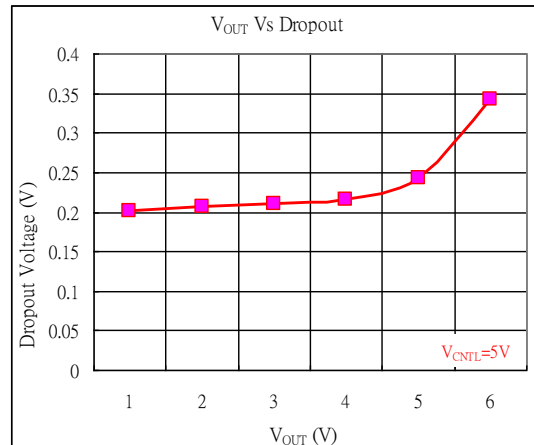
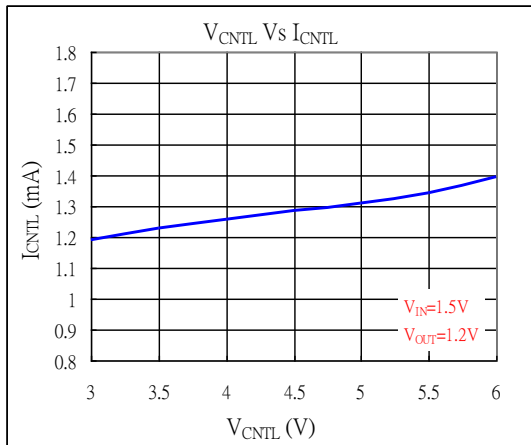

❖ TYPICAL CHARACTERISTICS (CONTINUES)

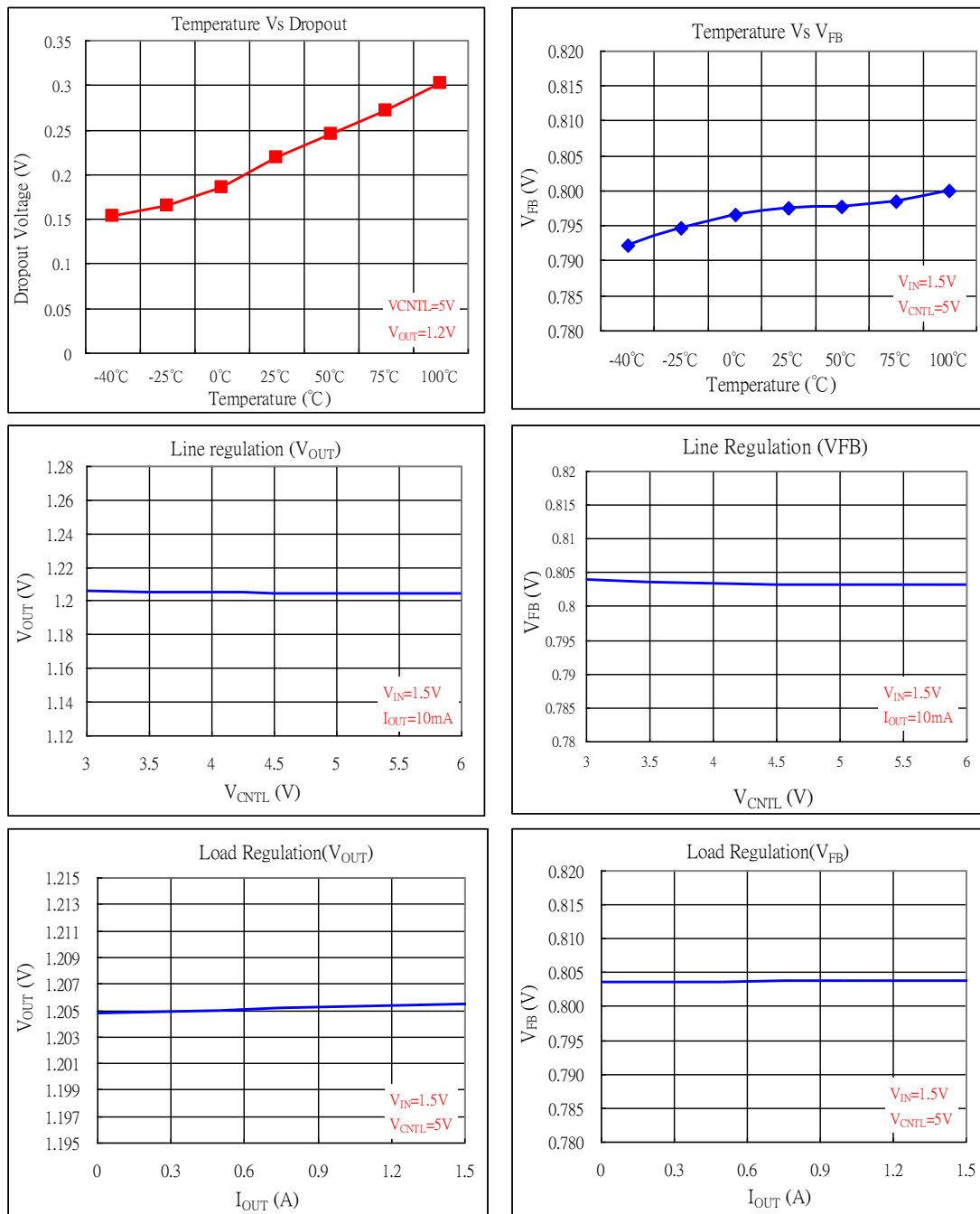

❖ PACKAGE OUTLINES

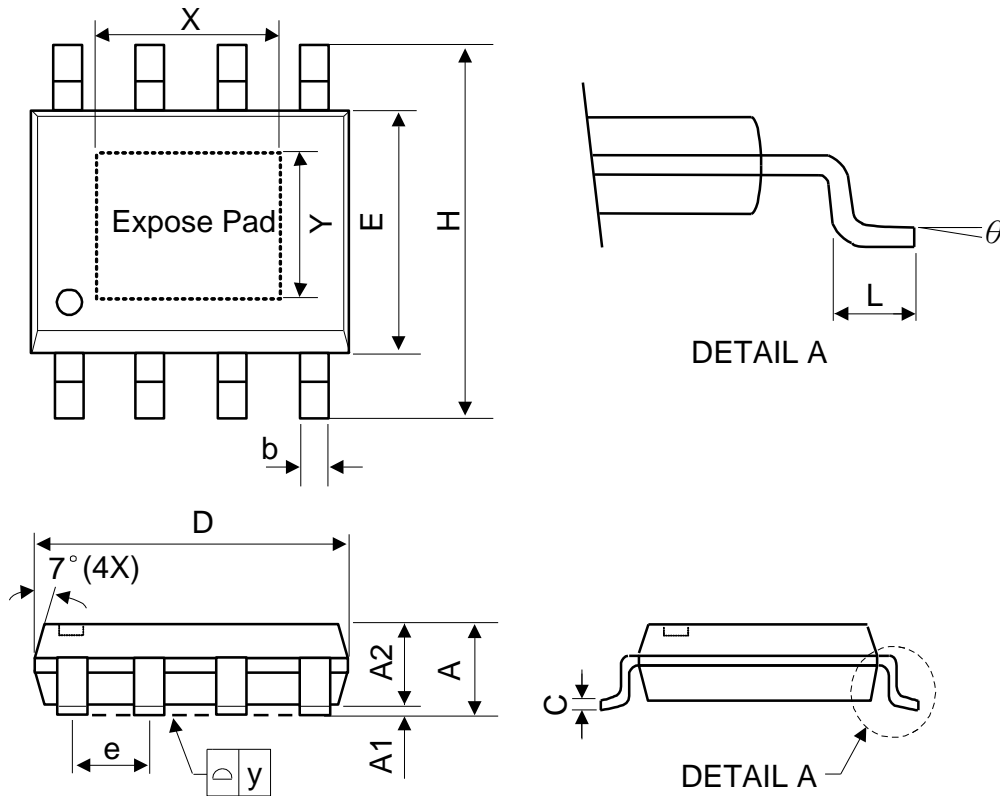

Symbol	Dimensions in Millimeters			Dimensions in Inches		
	Min.	Nom.	Max.	Min.	Nom.	Max.
A	-	-	1.75	-	-	0.069
A1	0	-	0.15	0	-	0.06
A2	1.25	-	-	0.049	-	-
C	0.1	0.2	0.25	0.0075	0.008	0.01
D	4.7	4.9	5.1	0.185	0.193	0.2
E	3.7	3.9	4.1	0.146	0.154	0.161
H	5.8	6	6.2	0.228	0.236	0.244
L	0.4	-	1.27	0.015	-	0.05
b	0.31	0.41	0.51	0.012	0.016	0.02
e	1.27 BSC			0.050 BSC		
y	-	-	0.1	-	-	0.004
X	-	2.34	-	-	0.092	-
Y	-	2.34	-	-	0.092	-
θ	0°	-	8°	0°	-	8°

Mold flash shall not exceed 0.25mm per side

JEDEC outline: MS-012 BA