

3-Terminal 200mA Positive Voltage Regulator

❖ GENERAL DESCRIPTION

The AX78H05 of positive voltage Regulator is inexpensive, easy-to-use devices suitable for a multitude of applications that require a regulated supply of up to 200mA. Like their higher power AX78H05, this regulator feature internal current limiting and thermal shutdown making them remarkably rugged. No external components are required with the AX78H05 device in many applications.

The device offer a substantial performance advantage over the traditional zener diode-resistor combination, as output impedance and quiescent current are substantially reduced.

❖ FEATURES

- Output Voltage : 5V
- Output current up to 200mA
- No external components required
- Internal thermal overload protection
- Internal short-circuit current limiting
- Output transistor safe-area compensation
- Output voltage offered in 4% tolerance

❖ PIN ASSIGNMENT

The package of AX78H05 is SOT89-3L; the pin assignment is given by:

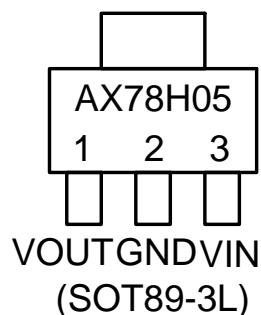

❖ ORDER/MARKING INFORMATION

Order Information	Top Marking
<p>AX78H05 X X</p> <p>Package Type F : SOT89 -3L</p> <p>Packing Blank: Tube A : Taping</p>	<p>GPI05 YML → Output Voltage L = Lot Code M = Month Code (A=Jan, B=Feb, C=Mar, D=Apr, E= May, F=Jun, G=Jul, H=Aug, I=Sep, J=Oct, K=Nov, L=Dec) Y = Year Code</p>

❖ ABSOLUTE MAXIMUM RATINGS (T_A = 25°C unless otherwise noted)

Characteristics	Symbol	Rating	Unit
DC Input Voltage	V _{IN}	35	V
Power Dissipation	P _D	Internal Limited	W
Operating Junction Temperature	T _J	-40 ~ +125	°C
Storage Temperature Range	T _{STG}	-65 ~ + 150	°C

❖ ELECTRICAL CHARACTERISTICS

(V_{IN} =10V, I_{OUT} = 40mA, 0°C ≤ T_J ≤125°C, C_{IN}=0.33uF, C_{OUT} = 0.1uF; unless otherwise specified.)

Characteristics	Symbol	Conditions	Min	Typ	Max	Units
Output voltage	V _{OUT}	T _J =25 °C	4.80	5	5.20	V
		7.5V ≤ V _{IN} ≤20V, 5mA ≤ I _{OUT} ≤100mA	4.75	5	5.25	
Line Regulation	REG _{line}	T _J =25 °C 7.5V ≤ V _{IN} ≤20V I _{OUT} =100mA	-	50	150	mV
Load Regulation	REG _{load}	T _J =25 °C 5mA ≤ I _{OUT} ≤100mA 5mA ≤ I _{OUT} ≤40mA	-	20 10	60 30	
Quiescent Current	I _q	I _{OUT} =0, T _J = 25 °C	-	3	6	mA
Quiescent Current Change	ΔI _q	7.5V ≤ V _{IN} ≤ 20V	-	-	1.5	
		5mA ≤ I _{OUT} ≤40mA	-	-	0.1	
Output Noise Voltage	V _n	10Hz ≤ f ≤ 100KHz, T _J = 25°C	-	40	-	μV
Ripple Rejection Ratio	P _{SRR}	f=120Hz, 7.5V ≤ V _{IN} ≤20V	41	49	-	dB
Voltage Drop	V _{drop}	I _{OUT} = 100mA, T _J =25°C	-	2	-	V
Peak Output Current	I _{o peak}	T _J = 25°C	-	0.27	-	A
Temperature Coefficient of Output Voltage	ΔV _{OUT} /ΔT _J	I _{OUT} = 5mA, 0°C ≤ T _J ≤ 125°C	-	-0.65	-	mV/°C

Note1: Pulse testing techniques are used to maintain the junction temperature as close to the ambient temperature as possible and thermal effects must be taken into account separately.

Note2: This specification applies only for DC power dissipation permitted by absolute maximum ratings.

❖ APPLICATION CIRCUIT

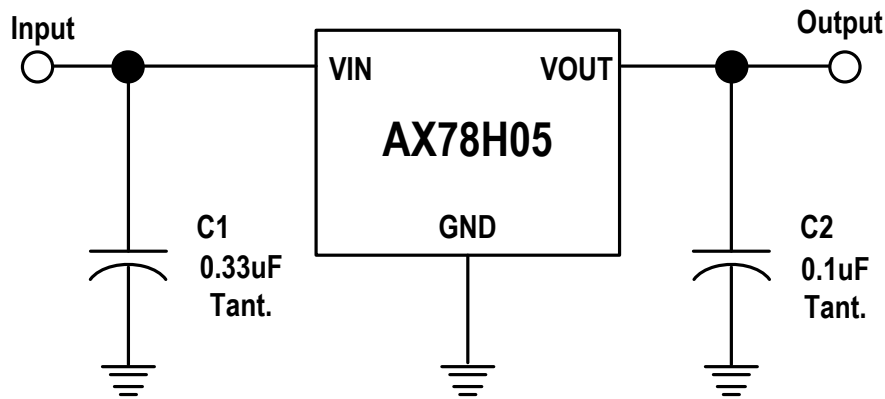

❖ APPLICATION INFORMATION

Design Considerations

The AX78H05 of fixed voltage regulator is designed with Thermal Overload Protection that shuts down the circuit when subjected to an excessive power overload condition. Internal Short Circuit protection limits the maximum current the circuit will pass.

In many low current applications, compensation capacitors are not required. However, it is recommended that the regulator input be bypassed with a capacitor if the regulator is connected to the power supply filter with long wire lengths, or if the output load capacitance is large. The input bypass capacitor should be selected to provide good high-frequency characteristics to insure stable operation under all load conditions. A 0.33uF or larger tantalum, Mylar, or other capacitor having low internal impedance at high frequencies should be chosen. The bypass capacitor should be mounted with the shortest possible leads directly across the regulators input terminals. Good construction techniques should be used to minimize ground loops and lead resistance drops since the regulator has no external sense lead. Bypassing the output is also recommended.

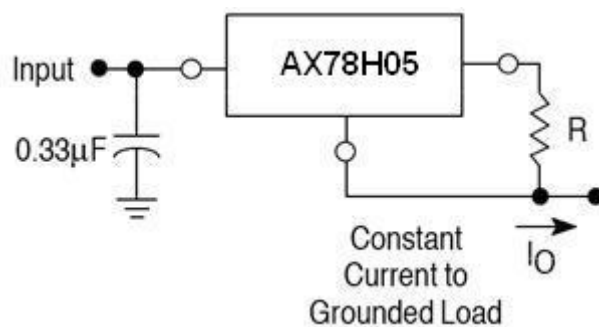

FIGURE 1 – Current Regulator

The AX78H05 regulator can also be used as a current source when connected as above. In order to minimize dissipation the AX78H05 is chosen in this application. Resistor R determines the current as follows:

$$I_O = \frac{5.0V}{R} + I_B$$

$$I_B = 3.8mA \text{ over lined and load changes}$$

For example, a 200mA current source would require R to be a 25Ω, 5W resistor and the output voltage compliance would be the input voltage less 7.5V.

❖ PACKAGE OUTLINES

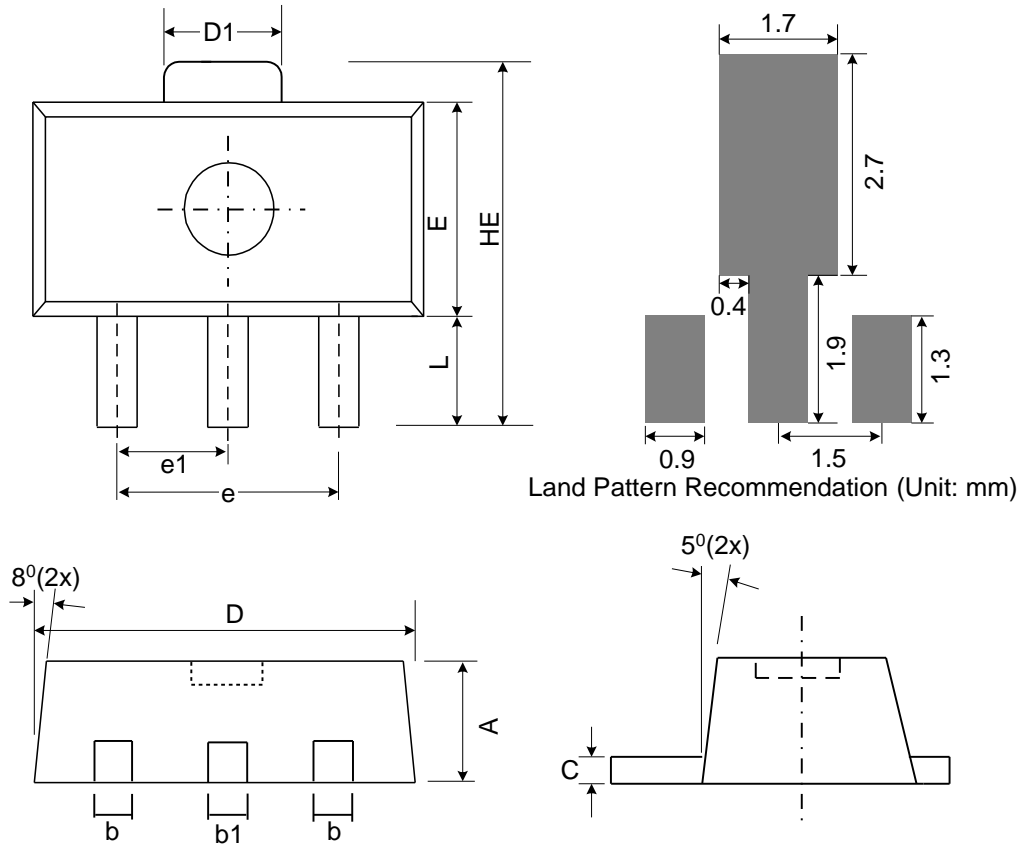

Symbol	Dimensions in Millimeters			Dimensions in Inches		
	Min.	Nom.	Max.	Min.	Nom.	Max.
A	1.40	1.50	1.60	0.055	0.059	0.063
b	0.36	0.42	0.48	0.014	0.017	0.019
b1	0.44	0.50	0.56	0.017	0.02	0.022
C	0.35	0.40	0.44	0.014	0.016	0.017
D	4.40	4.50	4.60	0.173	0.177	0.181
D1	1.35	1.59	1.83	0.053	0.063	0.072
e	3.0 BSC			0.118 BSC		
e1	1.5 BSC			0.059 BSC		
E	2.29	2.45	2.60	0.09	0.097	0.102
HE	3.94	4.10	4.25	0.155	0.161	0.167
L	0.80	1.00	1.20	0.031	0.04	0.047

JEDEC outline: TO-243 AB