

LCD-Module SPECIFICATION

AXSC202A

APPROVED BY	CHECKED BY	ORGANIZED BY
	Jeffrey	Tina

RECORD OF REVISION

Revision Date	Page	Contents
2003/07/29	-	New Release

1 FEATURES

- (1) Display format : 20 characters × 2 lines
- (2) Construction : STN LCD, Bezel, Zebra and PCB.
- (3) Optional LED or EL back-light.
- (4) Controller : KS0066U or Equivalent.
- (5) 5V single power input(Special request for 3.3V driving , built-in DC/DC converter)
- (6) Normal / Extended temperature type.

2 NUMBERING SYSTEM

AX__ - **202B** ____ - __
1 2 **3 4 5 6 7**

No	Code Value	Description	Remark
2	T	TN	LCD type
	H	HTN	
	S	STN yellow-green	
	G	STN Gray	
	B	STN Blue(Negative)	
	F	FSTN	
	C	STN-color	
	A	A-TFT	
	L	Ltps-TFT	
3	O	OLED	Display type
	C	Character-COB	
	D	Character-TAB	
	E	Character-COG	
	F	Character-COF	
	G	Graphic-COB	
	H	Graphic-TAB	
	K	Graphic-COG	
L	Graphic-COF		
3	A	Reflective type / 6:00 view	Polarizer / Viewing Angle
	B	Reflective type / 12:00 view	
	C	Transflective type / 6:00 view	
	D	Transflective type / 12:00 view	
	E	Transmissive type / 6:00 view	
	F	Transmissive type / 12:00 view	
	G	Negative type / 6:00 view	
	H	Negative type / 12:00 view	
	I	Negative type / 3:00 view	

4	None	None backlight	Backlight type
	L	LED array	
	Q	LED edge	
	E	EL	
	C	CCFL	
5	None	Without backlight	Backlight color
	A	Amber	
	B	Blue	
	G	Green	
	L	Yellow	
	O	Orange	
	R	Red	
	Y	Yellow-green	
	W	White	
6	None	Normal temperature type	LCM temperature type
	H	Extended temperature type	
7	00~99		Version code

3 MECHANICAL DATA

Parameter	Stand Value	Unit
Dot size	0.60(W) × 0.65(H)	mm
Dot pitch	0.65(W) × 0.70(H)	mm
Character size	3.20(W) × 5.55(H)	mm
Viewing area	83.0(W) × 18.5(H)	mm
Module size	116.0(W) × 37.0(H) × 10.0max (T))	mm
Module size (w / LED back-light)	116.0(W) × 37.0(H) × 14.5max (T))	mm

4 ABSOLUTE MAXIMUM RATINGS

Parameter		Symbol	Min	Max	Unit
Logic Circuit Supply Voltage		VDD-VSS	-0.3	7.0	V
LCD Driving Voltage		VDD-VO	-0.3	10.0	V
Input Voltage		VI	-0.3	VDD+0.3	V
Normal temp. type	Operating Temp.	TOP	0	50	°C
	Storage Temp.	TSTG	-20	70	°C

Extended temp. type	Operating Temp.	TOP	-20	70	°C
	Storage Temp.	TSTG	-30	80	°C

5 ELECTRO-OPTICAL CHARACTERISTICS

Parameter	Symbol	Condition	Min	Typ	Max	Unit	Note
----- Electronic Characteristics -----							
Logic Circuit Supply Voltage	VDD-VSS	--	2.7	--	5.5	V	
LCD Driving Voltage	VDD-VO	-20 °C	4.6	4.8	5.0	V	0 ~ 50 °C for Normal Temp. type -20 ~ 70 °C for Extended Temp. type
		0 °C	4.5	4.7	4.9		
		25 °C	4.4	4.6	4.8		
		50 °C	4.2	4.4	4.6		
		70 °C	4.00	4.2	4.4		
Input Voltage	VIH	--	0.7 VDD	--	VDD	V	
	VIL	--	VSS	--	0.3 VDD	V	
Logic Supply Current	IDD	VDD = 5V	--	1.6	2.0	mA	
----- Optical Characteristics -----							
Contrast	CR	25°C	--	5	--		Note 1
Rise Time	tr	25°C	--	80	120	ms	Note 2
Fall Time	tf	25°C	--	150	300	ms	
Viewing Angle Range	θ f	25°C & CR≥2	--	40	--	Deg.	Note 3
	θ b		--	35	--		
	θ l		--	35	--		
	θ r		--	35	--		
Frame Frequency	fF	25°C	--	64	--	Hz	
----- LED Back-light Characteristics -----							
Forward Voltage	VF	--	--	4.05	4.3	V	Supply Voltage between A&K
Forward Current	IF	VF=4.05V	--	500	--	mA	
Bare LED Luminous intensity		VF=4.05V	--	100	--	cd/m ²	
LCM Luminous intensity		VF=4.05V	--	35	--	cd/m ²	

* LED Dice number = 2×21=42

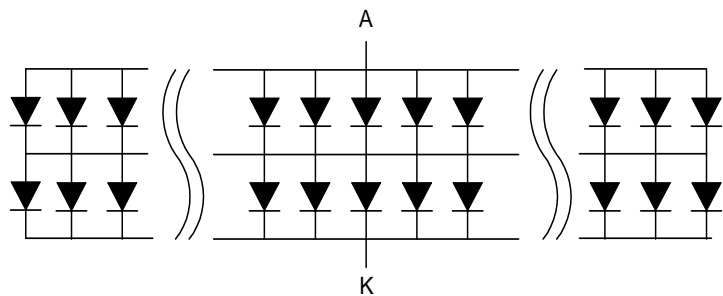

EL Back-light Characerics					
Parameter	Min	Typ	Max	Unit	Note
Driving Voltage	--	110	--	Vrms	
Frequency	--	400	--	Hz	
Bare EL Luminous intensity	--	45	--	cd/m ²	
LCM Luminous intensity	--	15	--	cd/m ²	

(NOTE 1) Contrast ratio :

$$CR = (\text{Brightness in OFF state}) / (\text{Brightness in ON state})$$

(NOTE 2) Response time :

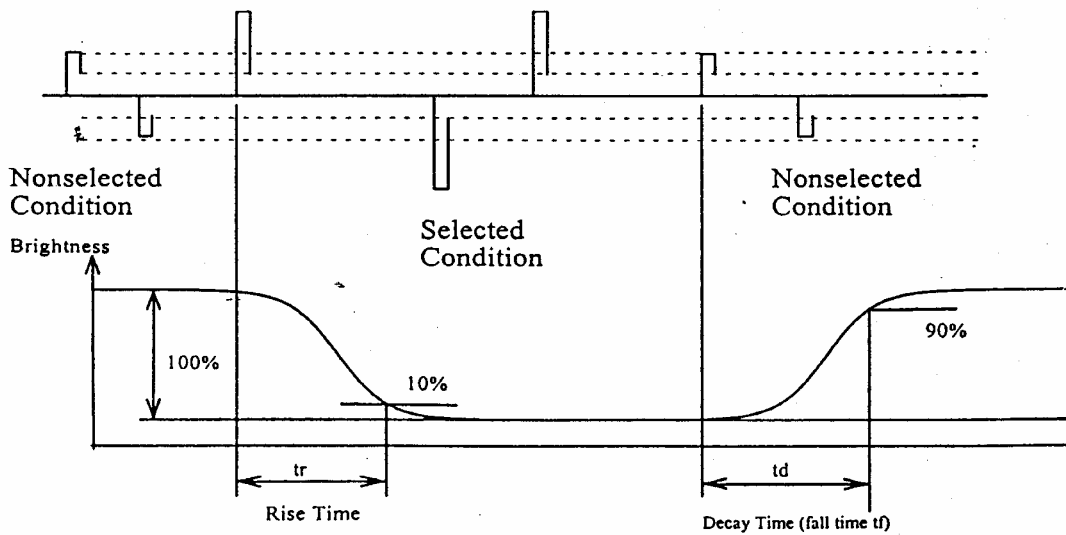

(NOTE 3) Viewing angle

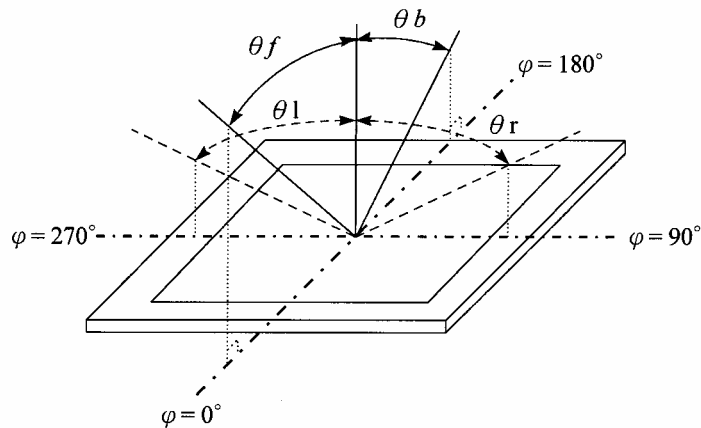

6 BLOCK DIAGRAM & INTERFACE

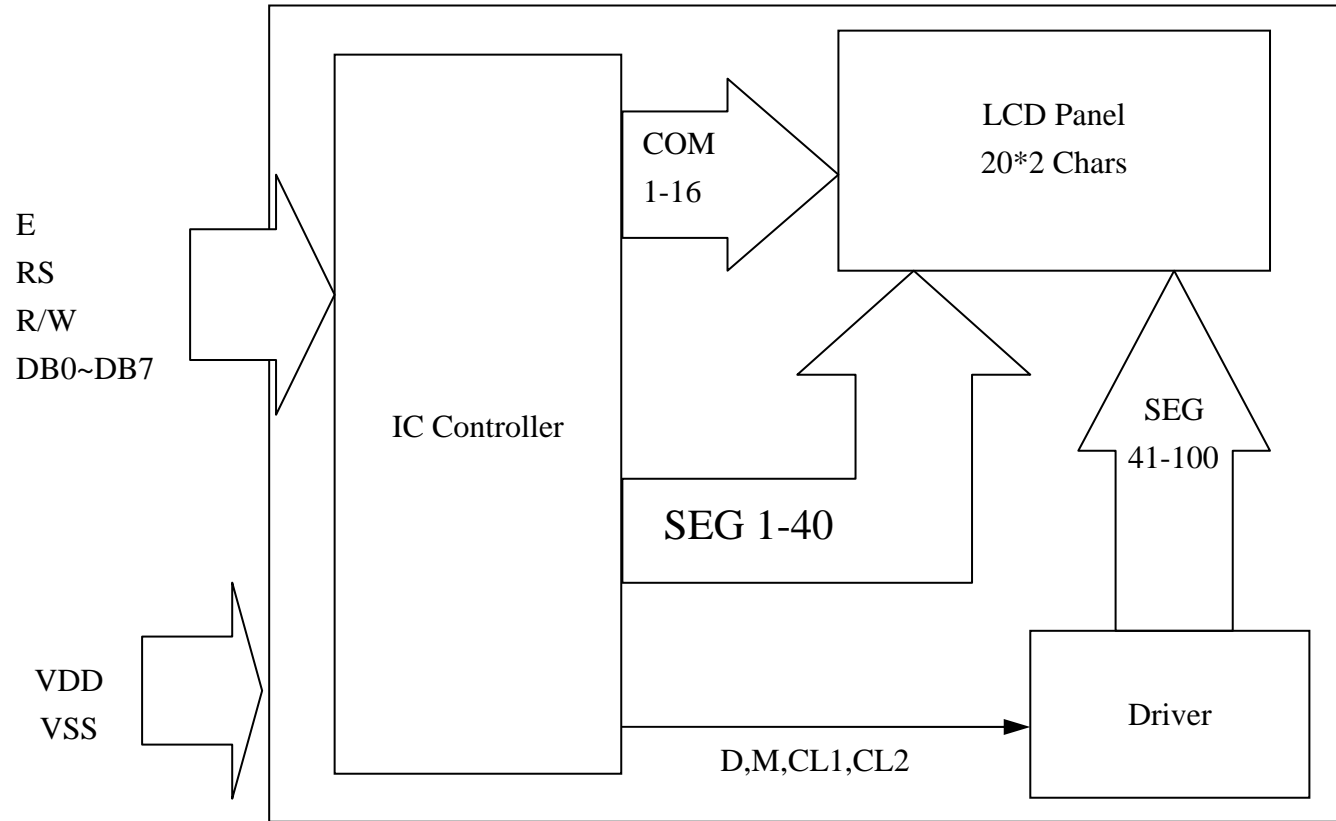

No.	Symbol	Function
1	VSS	Ground (0V)
2	VDD	Supply Voltage for Logic (+5V or +3.3V)
3	VO	Contrast Adjustment
4	RS	Data/Instruction Select
5	R/W	Read/Write Select
6	E	Enable Signal
7	DB0	Data Bus
8	DB1	Data Bus
9	DB2	Data Bus
10	DB3	Data Bus
11	DB4	Data Bus
12	DB5	Data Bus
13	DB6	Data Bus
14	DB7	Data Bus
15	LED_A	LED Power Supply + (5V)
16	LED_K	LED Power Supply - (5V)

7 POWER SUPPLY

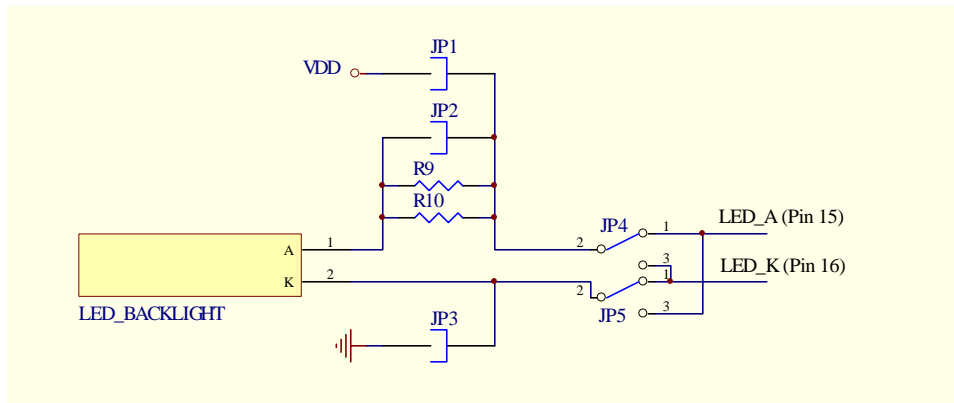
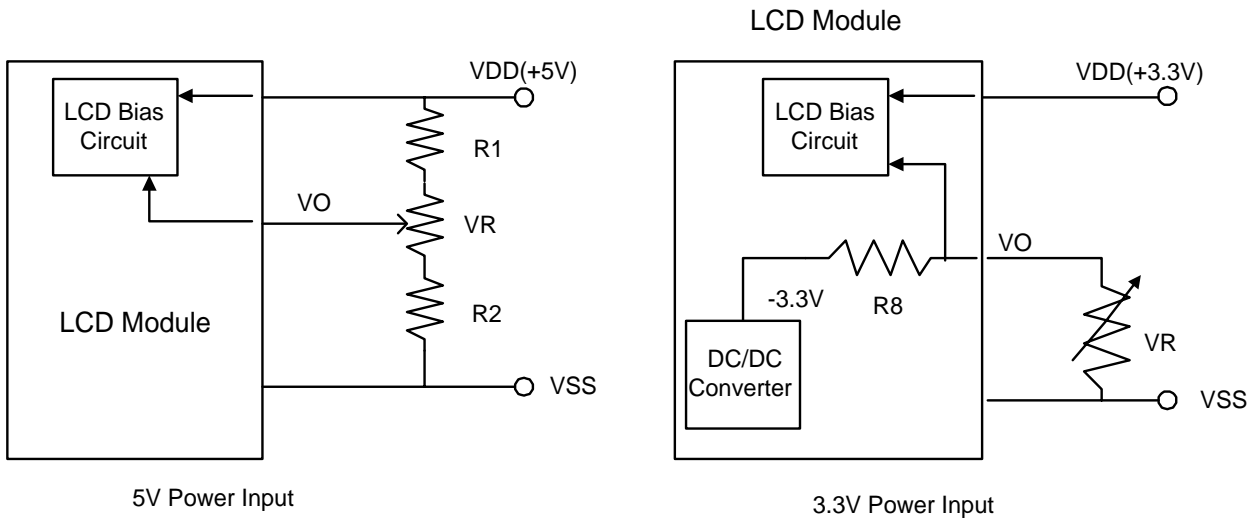

There are four methods to light up the LED back-light : (Please indicate while ordering.)

- (1) Built-in current-limit resistor(R9/R10). Add +5V between Pin15&16. (Default)
- (2) Add +4.05V between LED A & K directly.
- (3) Short JP2 and add +4.05V between Pin15&16.
- (4) Built-in current-limit resistor(R9/R10) and short JP1&JP3. Use the same power (+5V) with the logic circuit.

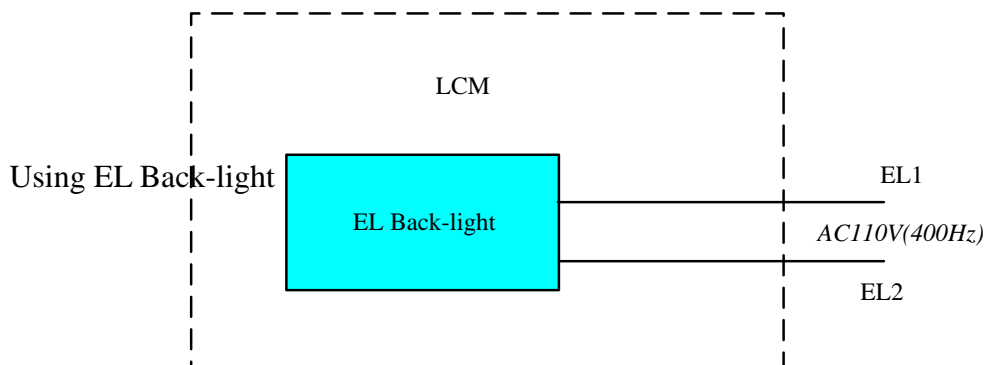

8 TIMING CHARACTERISTICS

Write Operation

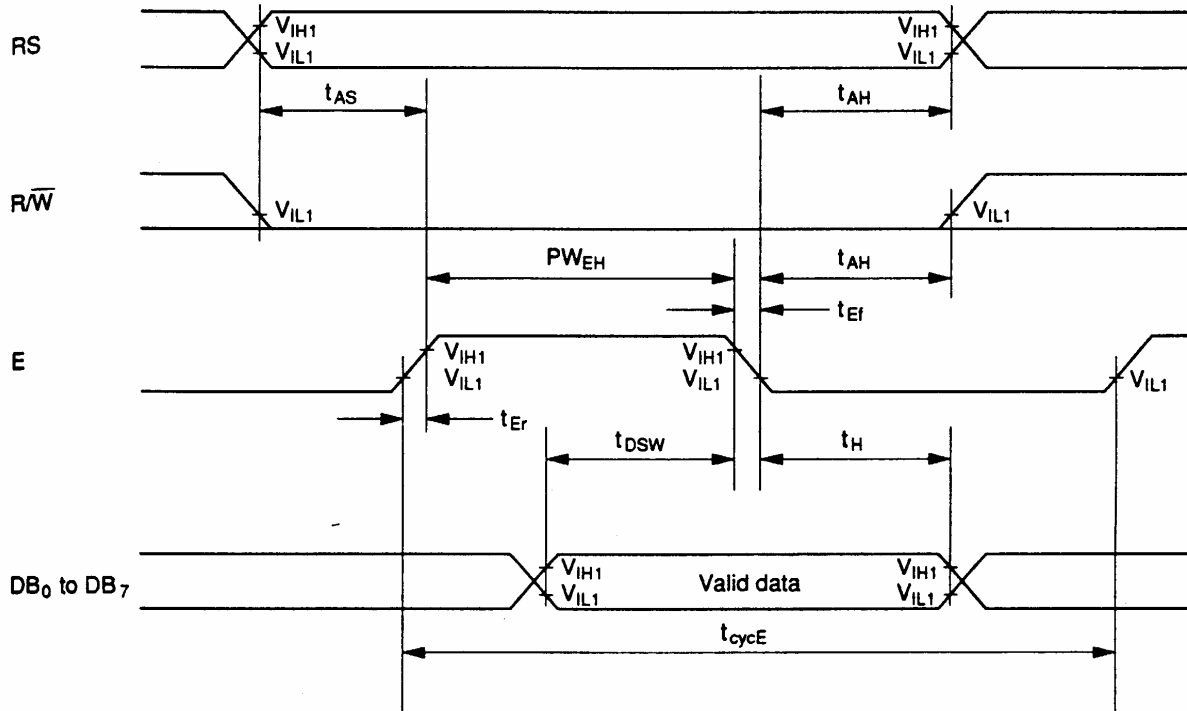

Item	Symbol	VDD=5V		VDD=3V		Unit
		Min	Max	Min	Max	
Enable cycle time	t_{CycE}	500	--	1000	--	ns
Enable pulse width	$PWEH$	230	--	450	--	
Enable rise/fall time	t_{Er}, t_{Ef}	--	20	--	25	
Address set-up time (RS, R/W to E)	t_{AS}	40	--	60	--	
Address hold time	t_{AH}	10	--	20	--	
Data set-up time	t_{DSW}	80	--	195	--	
Data hold time	t_H	10	--	10	--	

Read Operation

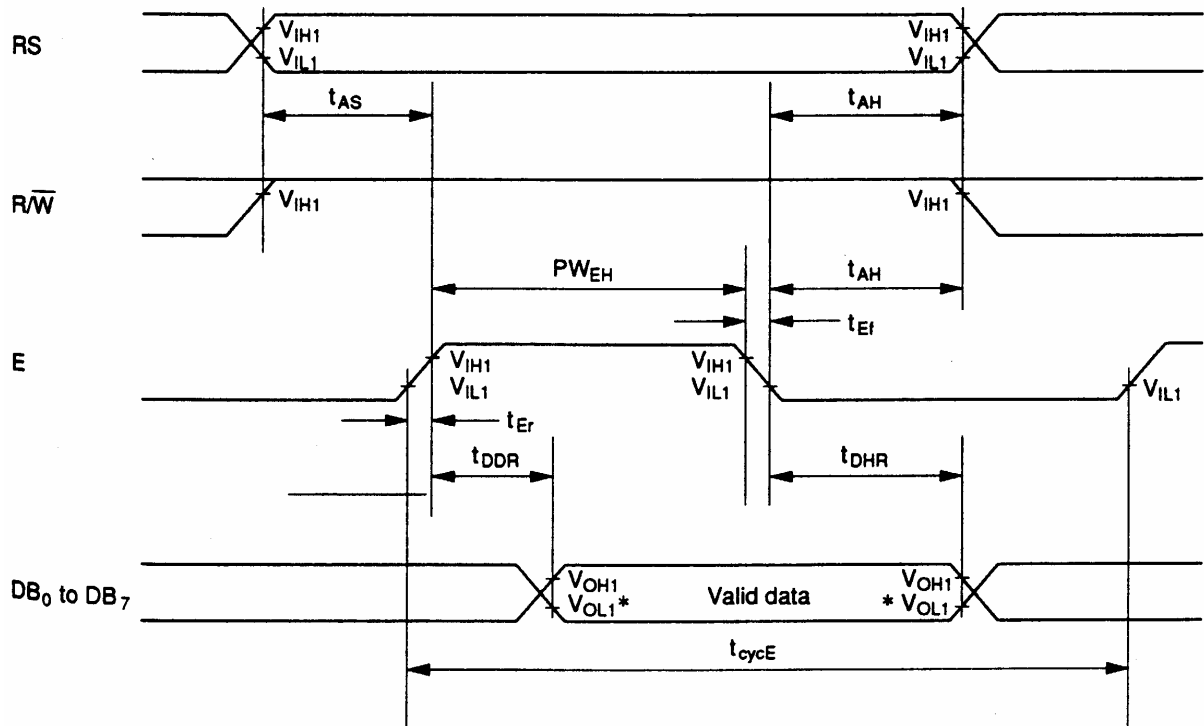

Item	Symbol	VDD=5V		VDD=3V		Unit
		Min	Max	Min	Max	
Enable cycle time	t _{cycE}	500	--	1000	--	ns
Enable pulse width	P _{WEH}	230	--	450	--	
Enable rise/fall time	t _{Er} ,t _{Ef}	--	20	--	25	
Address set-up time (RS, R/W to E)	t _{AS}	40	--	60	--	
Address hold time	t _{AH}	10	--	20	--	
Data set-up time	t _{DSW}	--	120	--	360	
Data hold time	t _H	5	--	5	--	

9 INSTRUCTION SET

Instruction	Code										Description
	RS	R/W	D7	D6	D5	D4	D3	D2	D1	D0	
Clear Display	0	0	0	0	0	0	0	0	0	1	Write "20H" to DDRAM and set DDRAM address to "00H" from AC
Return Home	0	0	0	0	0	0	0	0	1	--	Sets DD RAM address to "00H" from AC and return cursor to its original position if shifted. The contents of DDRAM are not changed.
Entry Mode SET	0	0	0	0	0	0	0	1	I/D	SH	Assign cursor moving direction and enable the shift of entire display.
Display ON/OFF Control	0	0	0	0	0	0	1	D	C	B	Set display (D), cursor (C), and blink of cursor (B) on/off control bit.
Cursor or Display Shift	0	0	0	0	0	1	S/C	R/L	--	--	Set cursor moving and display shift control bit, and the direction, without changing of DDRAM data.
Function Set	0	0	0	0	1	DL	N	F	--	--	Sets interface data length (DL:8-bit/4-bit), number of display lines (N:2-line/1-line) and , display font type (F:5x11dots/5x8 dost).
Set CG RAM Address	0	0	0	1	AC5	AC4	AC3	AC2	AC1	AC0	Sets CG RAM address in address counter.
Set DD RAM Address	0	0	1	AC6	AC5	AC4	AC3	AC2	AC1	AC0	Sets DD RAM address in address counter.
Read Busy Flag and Address	0	1	BF	AC6	AC5	AC4	AC3	AC2	AC1	AC0	Whether during internal operation or not can be known by reading BF. The contents of address counter can also be read.
Write Data to RAM	1	0	D7	D6	D5	D4	D3	D2	D1	D0	Writes data into internal RAM (DD RAM /CG RAM).
Read Data from RAM	1	1	D7	D6	D5	D4	D3	D2	D1	D0	Reads data from internal RAM (DD RAM /CG RAM).

* "--" : don't care

Note : When an MPU program with checking the Busy Flag(DB7) is made, it must be necessary $1/2F_{osc}$ is necessary for executing the next instruction by the falling edge of the 'E' signal after the Busy Flag(DB7) goes to "LOW".

10 INITIALIZATION SEQUENCE

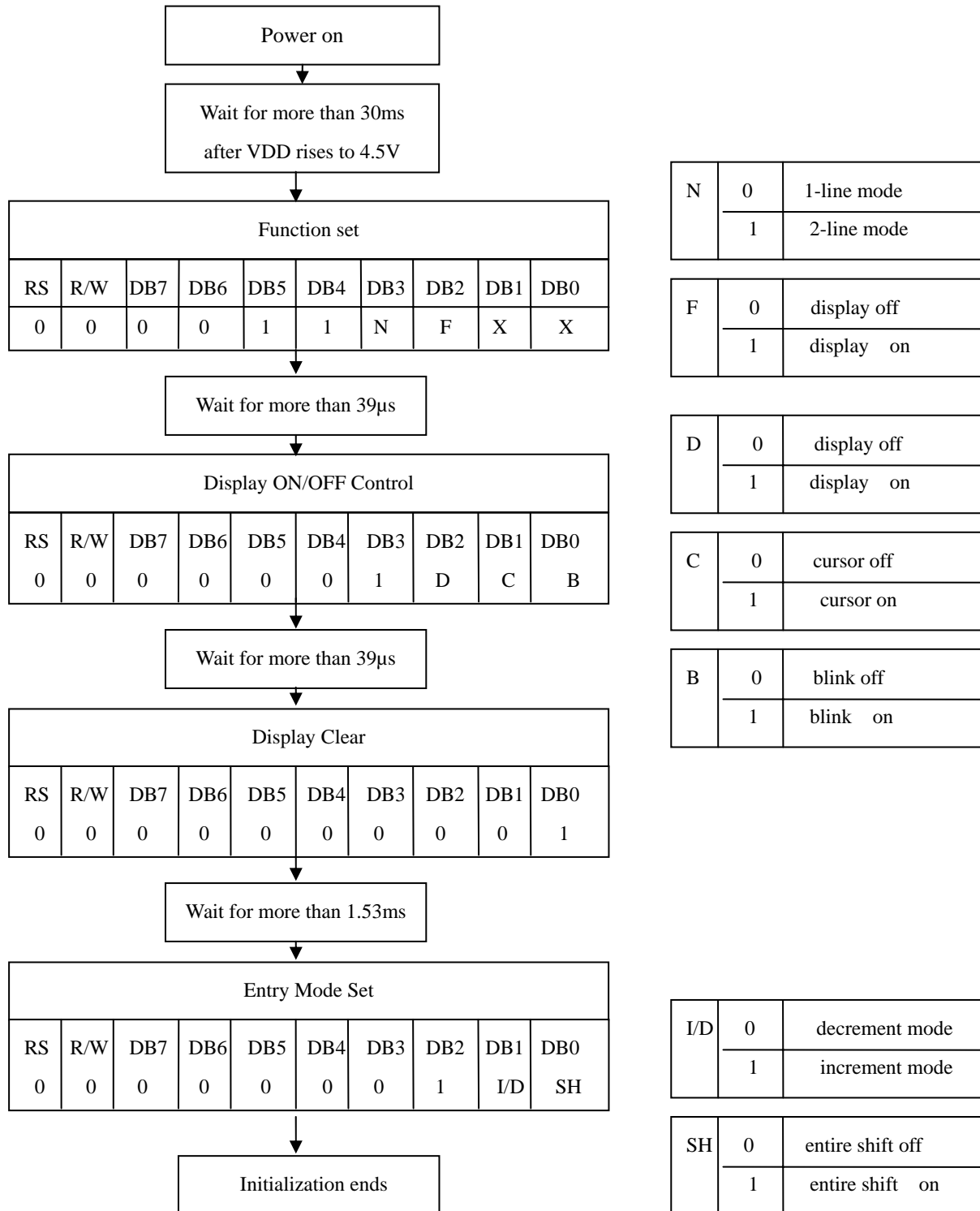

11 DD RAM ADDRESS

CHAR.	1	2	3	...	18	19	20
LINE 1	00	01	02	...	11	12	13
LINE 2	40	41	42	...	51	52	53

12 FONT TABLE

		Upper 4 Bits				Lower 4 Bits											
		0000	0001	0010	0011	0100	0101	0110	0111	1000	1001	1010	1011	1100	1101	1110	1111
xxxx0000	CG RAM (1)	█	█	█	█	█	█	█	█	█	█	█	█	█	█	█	█
xxxx0001	(2)	█	█	█	█	█	█	█	█	█	█	█	█	█	█	█	█
xxxx0010	(3)	█	█	█	█	█	█	█	█	█	█	█	█	█	█	█	█
xxxx0011	(4)	█	█	█	█	█	█	█	█	█	█	█	█	█	█	█	█
xxxx0100	(5)	█	█	█	█	█	█	█	█	█	█	█	█	█	█	█	█
xxxx0101	(6)	█	█	█	█	█	█	█	█	█	█	█	█	█	█	█	█
xxxx0110	(7)	█	█	█	█	█	█	█	█	█	█	█	█	█	█	█	█
xxxx0111	(8)	█	█	█	█	█	█	█	█	█	█	█	█	█	█	█	█
xxxx1000	(1)	█	█	█	█	█	█	█	█	█	█	█	█	█	█	█	█
xxxx1001	(2)	█	█	█	█	█	█	█	█	█	█	█	█	█	█	█	█
xxxx1010	(3)	█	█	█	█	█	█	█	█	█	█	█	█	█	█	█	█
xxxx1011	(4)	█	█	█	█	█	█	█	█	█	█	█	█	█	█	█	█
xxxx1100	(5)	█	█	█	█	█	█	█	█	█	█	█	█	█	█	█	█
xxxx1101	(6)	█	█	█	█	█	█	█	█	█	█	█	█	█	█	█	█
xxxx1110	(7)	█	█	█	█	█	█	█	█	█	█	█	█	█	█	█	█
xxxx1111	(8)	█	█	█	█	█	█	█	█	█	█	█	█	█	█	█	█

13 QUALITY AND RELIABILITY

13.1 TEST CONDITIONS

Tests should be conducted under the following conditions :

Ambient temperature : $25 \pm 5^{\circ}\text{C}$

Humidity : $60 \pm 25\% \text{ RH}$.

13.2 SAMPLING PLAN

Sampling method shall be in accordance with MIL-STD-105E, inspection level II, normal inspection, and single sampling plan tables for normal, tightened, and reduced inspection.

13.3 ACCEPTABLE QUALITY LEVEL

A major defect is defined as one that could cause failure to or materially reduce the usability of the unit for its intended purpose. A minor defect is one that does not materially reduce the usability of the unit for its intended purpose or is an infringement from established standards and has no significant bearing on its effective use or operation.

13.4 APPEARANCE

An appearance test should be conducted by human sight at approximately 30 cm distance from the LCD module under fluorescent light. The inspection area of LCD panel shall be within the range of following limits.

13.5 INSPECTION QUALITY CRITERIA

Item	Description of defects			Class of Defects	Acceptable level (%)	
Function	Short circuit or Pattern cut			Major	0.65	
Dimension	Deviation from drawings			Major	1.5	
Black spots	Ave . dia . D	area A	area B	Minor	2.5	
	$D \leq 0.2$	Disregard				
	$0.2 < D \leq 0.3$	3	4			
	$0.3 < D \leq 0.4$	2	3			
	$0.4 < D$	0	1			
Black lines	Width W, Length L		A	B	Minor	2.5
	$W \leq 0.03$		disregard			
	$0.03 < W \leq 0.05$		3	4		
	$0.05 < W \leq 0.07, L \leq 3.0$		1	1		
	See line criteria					
Bubbles in polarizer	Average diameter D $0.2 < D < 0.5$ mm for N = 4 , D > 0.5 for N = 1			Minor	2.5	
Color uniformity	Rainbow color or newton ring.			Minor	2.5	
Glass Scratches	Obvious visible damage.			Minor	2.5	
Contrast ratio	See note 1			Minor	2.5	
Response time	See note 2			Minor	2.5	
Viewing angle	See note 3			Minor	2.5	

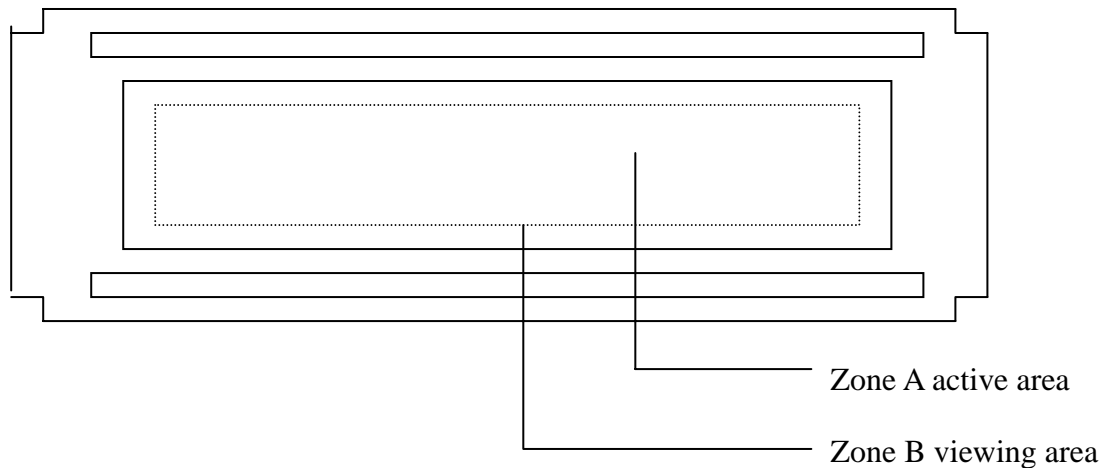

13.6 RELIABILITY

Test Item	Test Conditions	Note
	Normal Temp. type	
High Temperature Operation	50±3°C , t=96 hrs	
Low Temperature Operation	0±3°C , t=96 hrs	
High Temperature Storage	70±3°C , t=96 hrs	1,2
Low Temperature Storage	-20±3°C , t=96 hrs	1,2
Thermal Shock Test	-20°C ~ 25°C ~ 70°C 30 min. 5 min. 30 min. (1 cycle) Total 5 cycle	1,2
Humidity Test	40 °C, Humidity 90%, 96 hrs	1,2
Vibration Test (Packing)	Sweep frequency : 10 ~ 55 ~ 10 Hz/1min Amplitude : 0.75mm Test direction : X.Y.Z/3 axis Duration : 30min/each axis	2

Note 1 : Condensation of water is not permitted on the module.

Note 2 : The module should be inspected after 1 hour storage in normal conditions (15-35°C , 45-65%RH).

Definitions of life end point :

- Current drain should be smaller than the specific value.
- Function of the module should be maintained.
- Appearance and display quality should not have degraded noticeably.
- Contrast ratio should be greater than 50% of the initial value.

14 HANDLING PRECAUTIONS

- (1) An LCD module is a fragile item and should not be subjected to strong mechanical shocks.
- (2) Avoid applying pressure to the module surface. This will distort the glass and cause a change in colour.
- (3) Under no circumstances should the position of the bezel tabs or their shape be modified.
- (4) Do not modify the display PCB in either shape or positioning of components.
- (5) Do not modify or move location of the zebra or heat seal connectors.
- (6) The device should only be soldered to during interfacing. Modification to other areas of the board should not be carried out.
- (7) In the event of LCD breakage and resultant leakage of fluid do not inhale, ingest or make contact with the skin. If contact is made rinse immediately.
- (8) When cleaning the module use a soft damp cloth with a mild solvent, such as Isopropyl or Ethyl alcohol. The use of water, ketone or aromatic is not permitted.
- (9) Prior to initial power up input signals should not be applied.
- (10) Protect the module against static electricity and observe appropriate anti-static precautions.

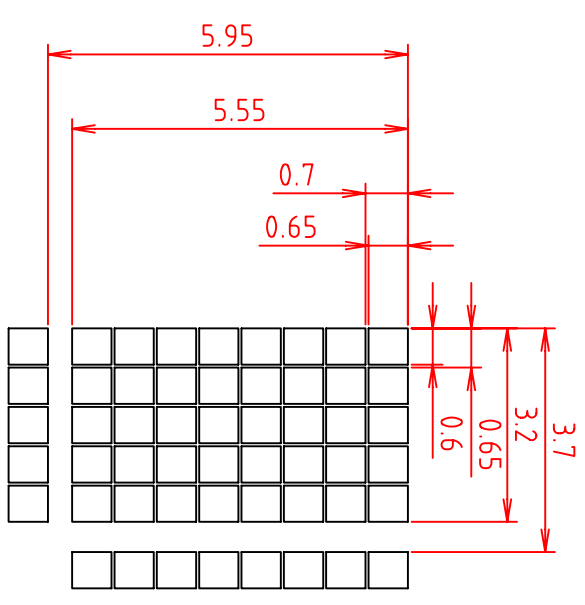
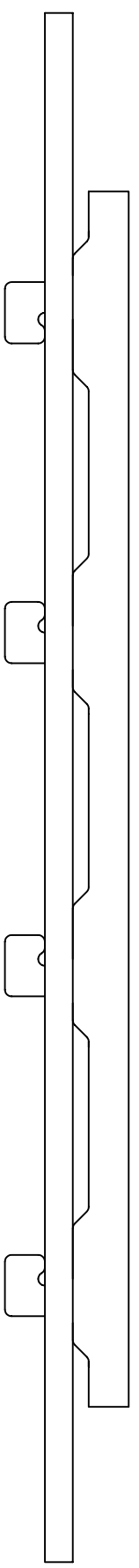
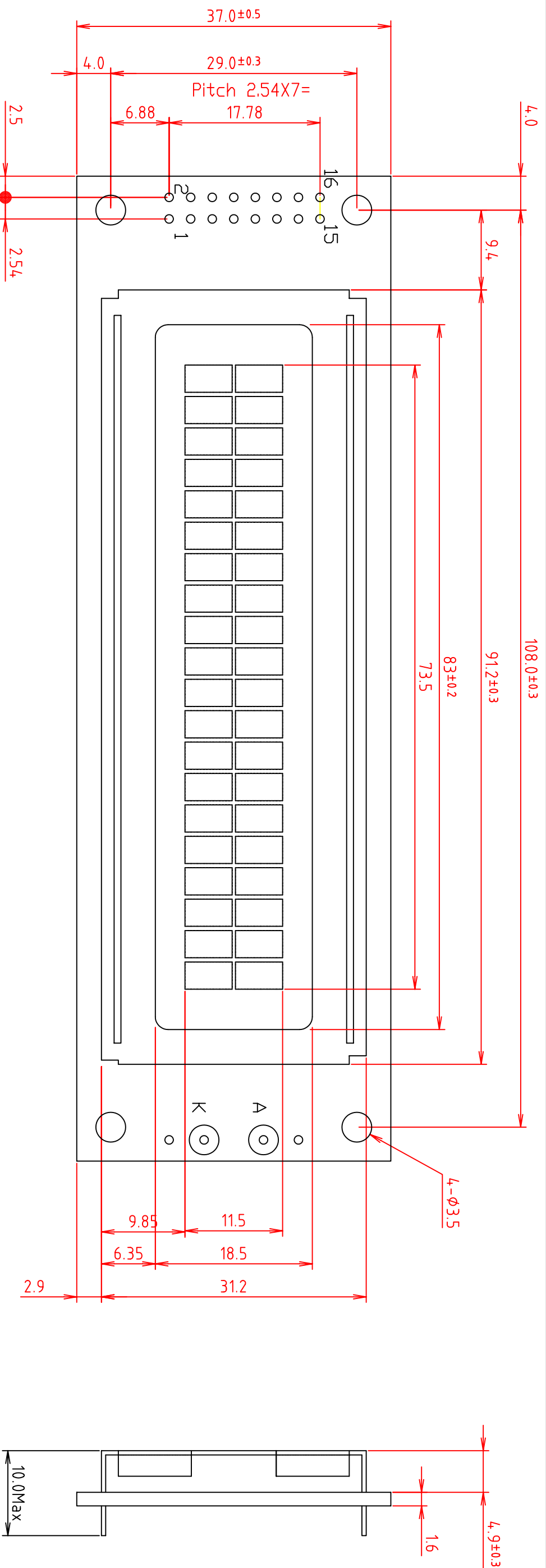

APEX DISPLAY CO., LTD.
晶英光電科技股份有限公司

Check By
Drawn By

Jeffrey

Approved By

Date 2003/07/22
Projection Type

Scale 2:1
UNIT mm

Product No.
AXSC202A

TITLE
OUTWARD DWG

Drawing NO.
AXSC202A-A-01-02

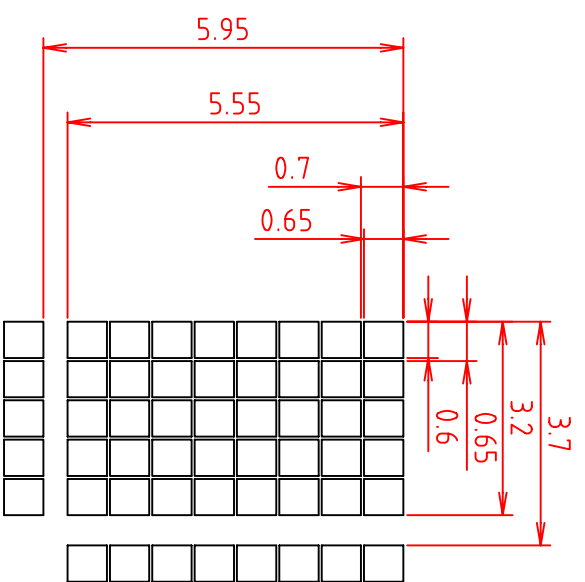
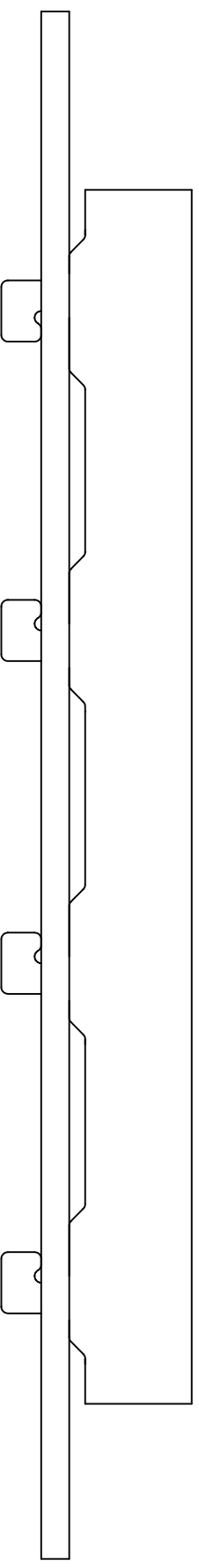
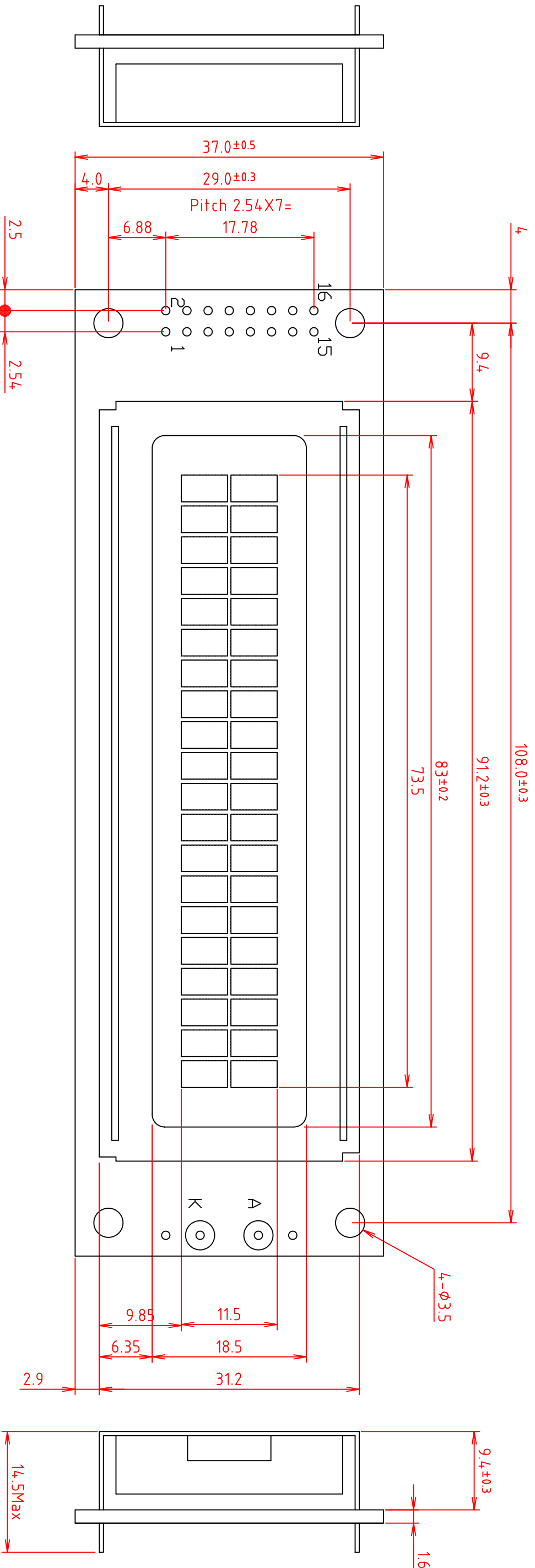

APEX DISPLAY CO., LTD.
晶英光電科技股份有限公司

Check By
Drawn By

Jeffrey

Approved By

Date 2003/07/22
Projection Type

Scale 2:1
UNIT mm

Product No.
AXSC202A

TITLE
OUTWARD DWG

Drawing NO.
AXSC202A-A-02-02