

LCD-Module SPECIFICATION

Approved by Customer

| | | |
|-----------------------------|--|--|
| Approved by Customer | | |
| | | |

AXSC402ACLYN05

| APPROVED BY | CHECKED BY | ORGANIZED BY |
|--------------------|-------------------|---------------------|
| | Jeffrey | Tina |

RECORD OF REVISION

| Revision Date | Page | Contents |
|---------------|------|-------------|
| 2003/12/02 | - | New Release |

1 FEATURES

- (1) Display format : 40 characters × 2 lines
- (2) Construction : STN LCD, Bezel, Zebra and PCB..
- (3) Optional LED or EL back-light.
- (4) Controller : KS0066U or Equivalent.
- (5) 5V single power input. (Special request for 3.3V driving, built-in DC/DC converter.)
- (6) Normal / Extended temperature type.
- (7) Excellent LC : VOP maintains at 5V for whole temp. range, no need extra temp. compensation circuit.
- (8) Special Request:Black Bezel,Blue color PCB, Maru-M & APEX Logo

2 NUMBERING SYSTEM

AX__ - 402A _____ - _
1 2 3 4 5 6 7

| No | Code Value | Description | Remark |
|----|---------------------------|---------------------------------|---------------------------|
| 2 | T | TN | LCD type |
| | H | HTN | |
| | S | STN yellow-green | |
| | G | STN Gray | |
| | B | STN Blue(Negative) | |
| | F | FSTN | |
| | C | STN-color | |
| | A | A-TFT | |
| | L | Ltps-TFT | |
| 3 | O | OLED | Display type |
| | C | Character-COB | |
| | D | Character-TAB | |
| | E | Character-COG | |
| | F | Character-COF | |
| | G | Graphic-COB | |
| | H | Graphic-TAB | |
| | K | Graphic-COG | |
| 3 | L | Graphic-COF | Polarizer / Viewing Angle |
| | A | Reflective type / 6:00 view | |
| | B | Reflective type / 12:00 view | |
| | C | Transflective type / 6:00 view | |
| | D | Transflective type / 12:00 view | |
| | E | Transmissive type / 6:00 view | |
| | F | Transmissive type / 12:00 view | |
| G | Negative type / 6:00 view | | |

| | | | |
|---|-------|----------------------------|----------------------|
| | H | Negative type / 12:00 view | |
| | I | Negative type / 3:00 view | |
| 4 | N | None backlight | Backlight type |
| | L | LED array | |
| | Q | LED edge | |
| | E | EL | |
| | C | CCFL | |
| 5 | None | Without backlight | Backlight color |
| | A | Amber | |
| | B | Blue | |
| | G | Green | |
| | L | Yellow | |
| | O | Orange | |
| | R | Red | |
| | Y | Yellow-green | |
| W | White | | |
| 6 | None | Normal temperature type | LCM temperature type |
| | H | Extended temperature type | |
| 7 | 00~99 | | Version code |

3 MECHANICAL DATA

| Parameter | Stand Value | Unit |
|---------------------------------|-----------------------------------|------|
| Dot size | 0.60(W) × 0.65(H) | mm |
| Dot pitch | 0.65(W) × 0.7(H) | mm |
| Character size | 3.2(W) × 5.55(H) | mm |
| Viewing area | 154.0(W) × 16.5(H) | mm |
| Module size | 182.0(W) × 33.5(H) × 10.5 max (T) | mm |
| Module size (LED back-light) | 182.0(W) × 54.0(H) × 14.0 max (T) | mm |

4 ABSOLUTE MAXIMUM RATINGS

| Parameter | | Symbol | Min | Max | Unit |
|------------------------------|-----------------|---------|------|---------|------|
| Logic Circuit Supply Voltage | | VDD-VSS | -0.3 | 7.0 | V |
| LCD Driving Voltage | | VDD-VO | -0.3 | 10.0 | V |
| Input Voltage | | VI | -0.3 | VDD+0.3 | V |
| Normal temp. type | Operating Temp. | TOP | 0 | 50 | °C |
| | Storage Temp. | TSTG | -20 | 70 | °C |
| Extended temp. type | Operating Temp. | TOP | -20 | 70 | °C |
| | Storage Temp. | TSTG | -30 | 80 | °C |

5 ELECTRO-OPTICAL CHARACTERISTICS

| Parameter | Symbol | Condition | Min | Typ | Max | Unit | Note |
|---|---------|-------------------|---------|-----|---------|-------------------|--|
| ----- Electronic Characteristics ----- | | | | | | | |
| Logic Circuit Supply Voltage | VDD-VSS | -- | 2.7 | -- | 5.5 | V | |
| LCD Driving Voltage (STN) | VDD-VO | -20 °C | 4.75 | 5.0 | 5.25 | V | 0 ~ 50 °C for Normal Temp. type -20 ~ 70 °C for Extended Temp. type |
| | | 0 °C | 4.75 | 5.0 | 5.25 | | |
| | | 25 °C | 4.75 | 5.0 | 5.25 | | |
| | | 50 °C | 4.75 | 5.0 | 5.25 | | |
| | | 70 °C | 4.75 | 5.0 | 5.25 | | |
| Input Voltage | VIH | -- | 0.7 VDD | -- | VDD | V | |
| | VIL | -- | VSS | -- | 0.3 VDD | V | |
| Logic Supply Current | IDD | VDD = 5V | -- | 2.0 | 3.0 | mA | |
| ----- Optical Characteristics ----- | | | | | | | |
| Contrast | CR | 25 °C | -- | 5 | -- | | Note 1 |
| Rise Time | tr | 25 °C | -- | 80 | 120 | ms | Note 2 |
| Fall Time | tf | 25 °C | -- | 150 | 300 | ms | |
| Viewing Angle Range | θ f | 25 °C & CR ≥ 2 | -- | 40 | -- | Deg. | Note 3 |
| | θ b | | -- | 35 | -- | | |
| | θ l | | -- | 35 | -- | | |
| | θ r | | -- | 35 | -- | | |
| Frame Frequency | fF | 25 °C | -- | 64 | -- | Hz | |
| ----- LED Back-light Characteristics ----- | | | | | | | |
| Forward Voltage | VF | -- | 3.8 | 4.2 | 4.5 | V | Supply Voltage between A&K |
| Forward Current | IF | VF=4.2V | -- | 310 | -- | mA | |
| Bare LED Luminous intensity | | VF=4.2V | -- | 190 | -- | cd/m ² | |
| LCM Luminous intensity | | VF=4.2V | -- | 35 | -- | cd/m ² | |

* LED Dice number = 2×28=56

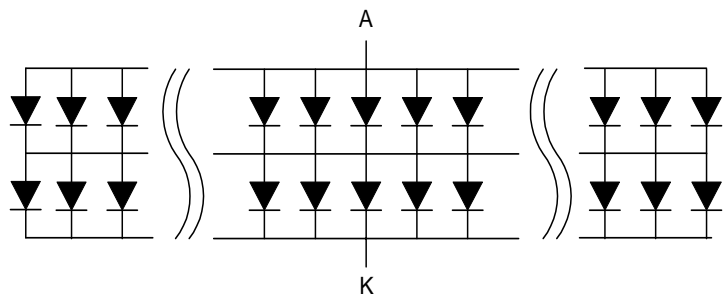

| ----- EL Back-light Characteristics ----- | | | | | |
|---|-----|-----|-----|-------------------|------|
| Parameter | Min | Typ | Max | Unit | Note |
| Driving Voltage | -- | 110 | -- | Vrms | |
| Frequency | -- | 400 | -- | Hz | |
| Bare EL Luminous intensity | -- | 45 | -- | cd/m ² | |
| LCM Luminous intensity | -- | 15 | -- | cd/m ² | |

(NOTE 1) Contrast ratio :

$$CR = (\text{Brightness in OFF state}) / (\text{Brightness in ON state})$$

(NOTE 2) Response time :

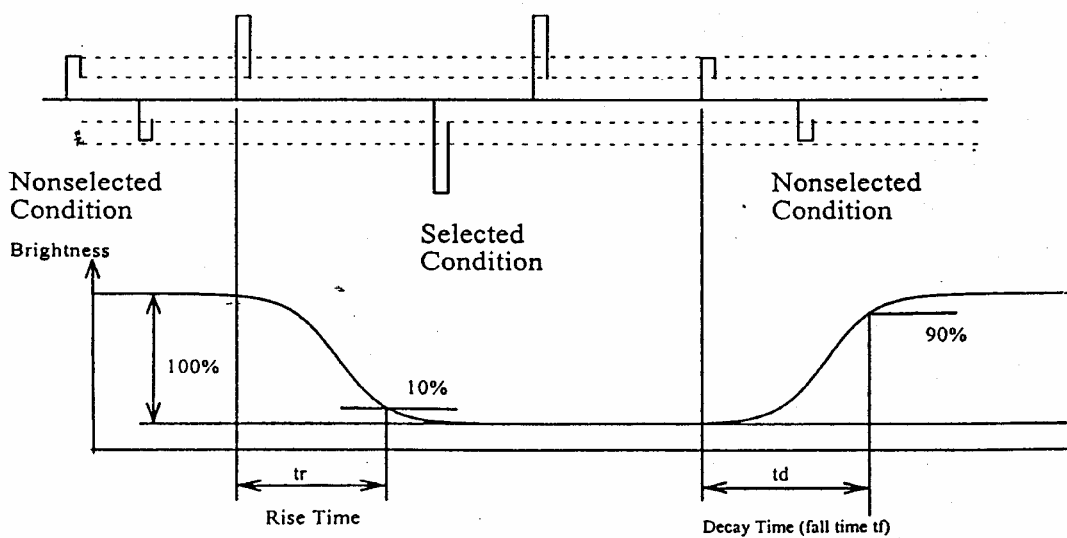

(NOTE 3) Viewing angle

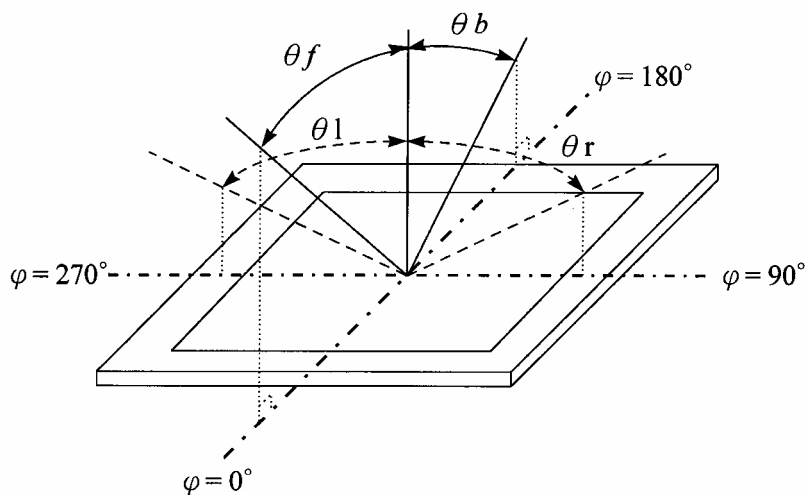

6 BLOCK DIAGRAM & INTERFACE

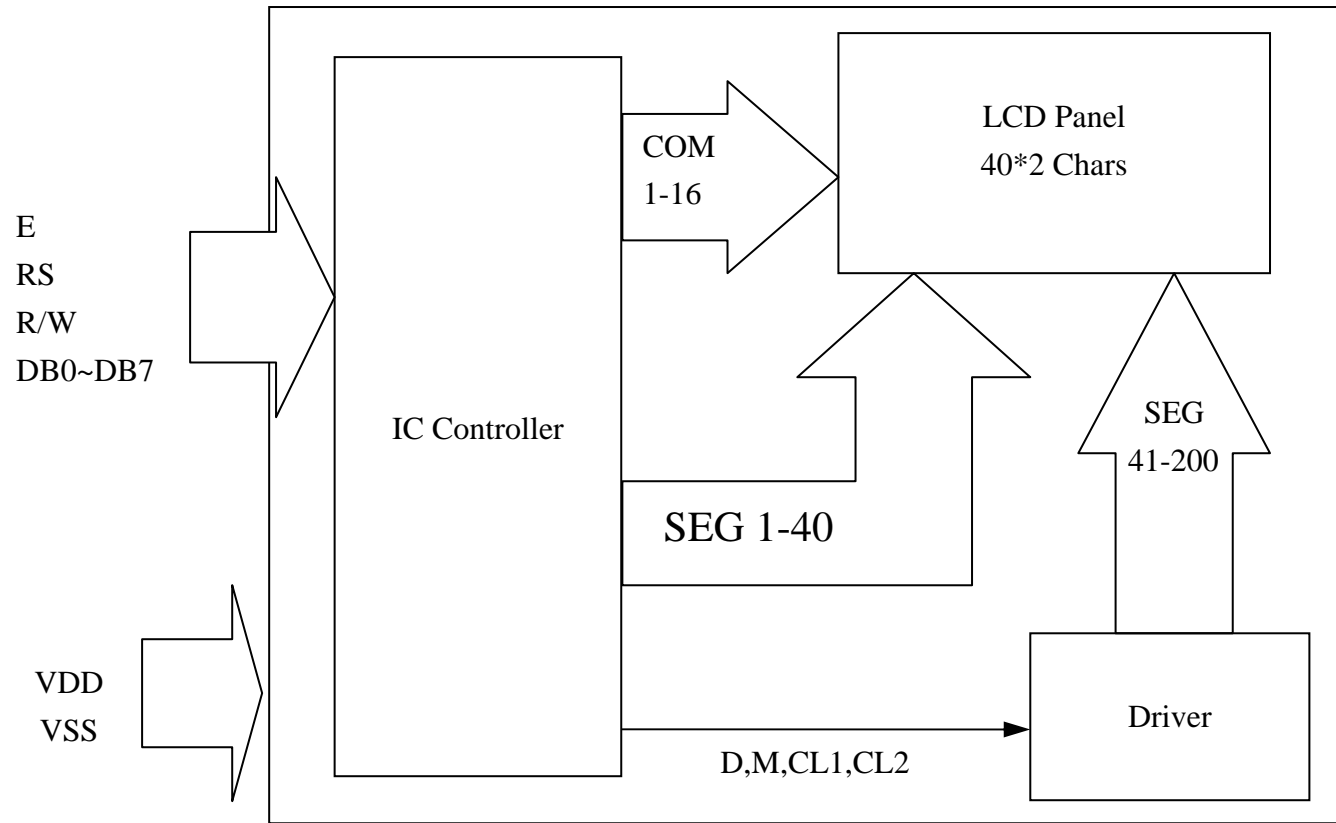

| No. | Symbol | Function |
|-----|--------|---|
| 1 | VSS | Ground (0V) |
| 2 | VDD | Supply Voltage for Logic (+5V or +3.3V) |
| 3 | VO | Contrast Adjustment |
| 4 | RS | Data/Instruction Select |
| 5 | R/W | Read/Write Select |
| 6 | E | Enable Signal |
| 7 | DB0 | Data Bus |
| 8 | DB1 | Data Bus |
| 9 | DB2 | Data Bus |
| 10 | DB3 | Data Bus |
| 11 | DB4 | Data Bus |
| 12 | DB5 | Data Bus |
| 13 | DB6 | Data Bus |
| 14 | DB7 | Data Bus |
| 15 | LED_A | LED Power Supply + (5V) |
| 16 | LED_K | LED Power Supply - (5V) |

7 POWER SUPPLY

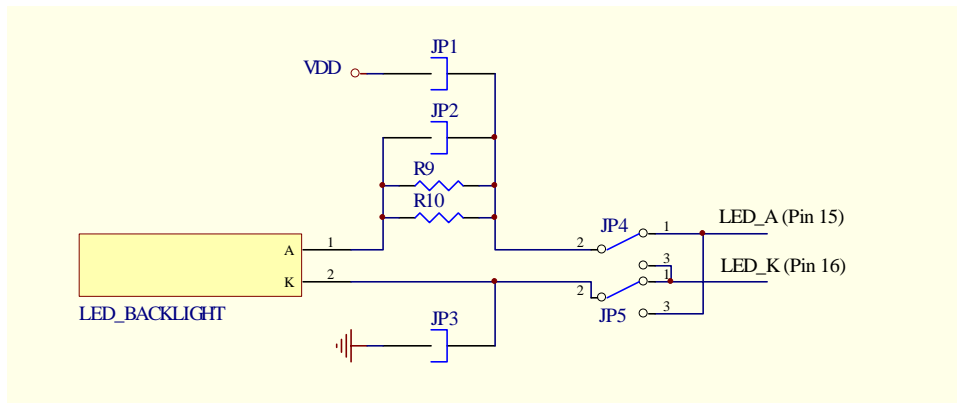
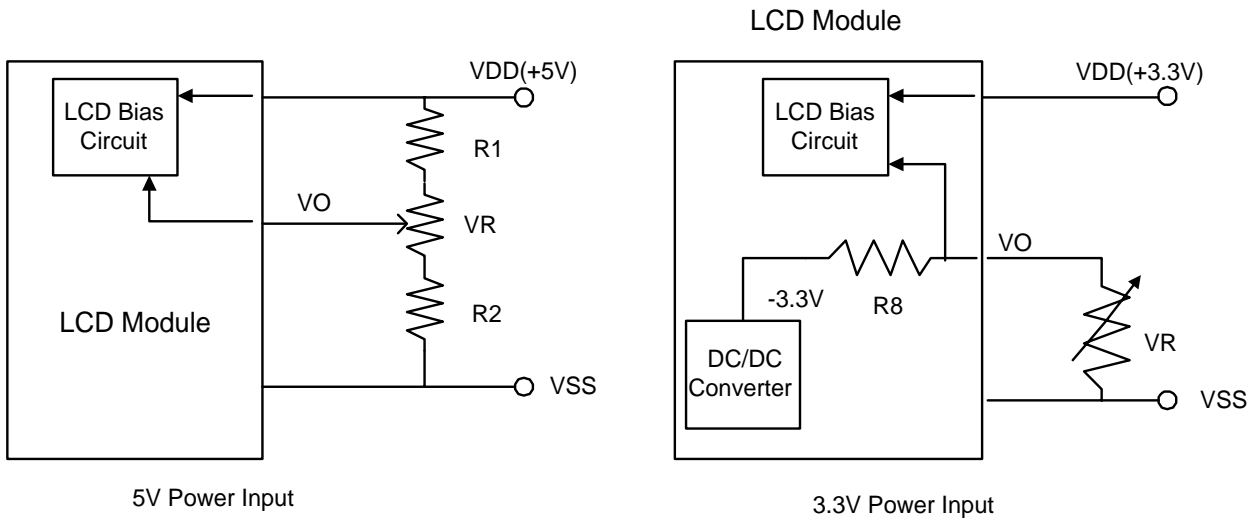

There are four methods to light up the LED back-light : (Please indicate while ordering.)

- (1) Built-in current-limit resistor(R9/R10). Add +5V between Pin15&16. (Default)
- (2) Add +4.05V between LED A & K directly.
- (3) Short JP2 and add +4.05V between Pin15&16.
- (4) Built-in current-limit resistor(R9/R10) and short JP1&JP3. Use the same power (+5V) with the logic circuit.

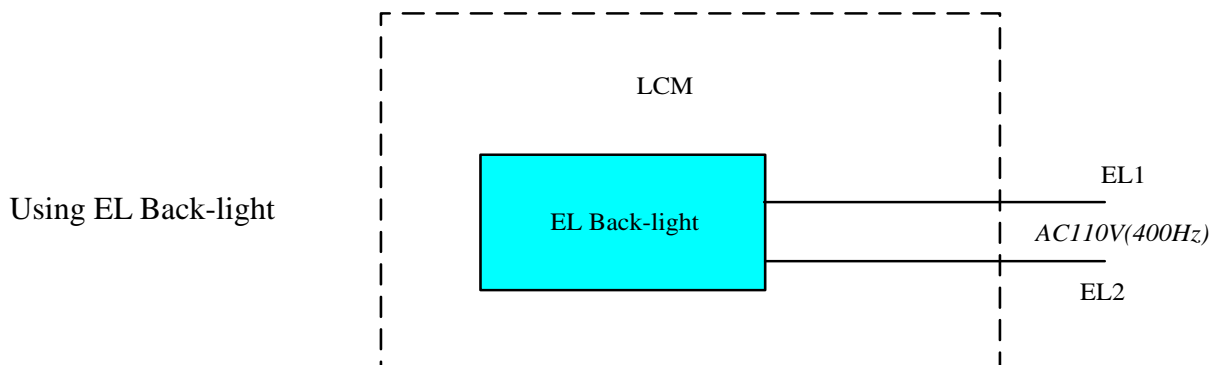

8 TIMING CHARACTERISTICS

Write Operation

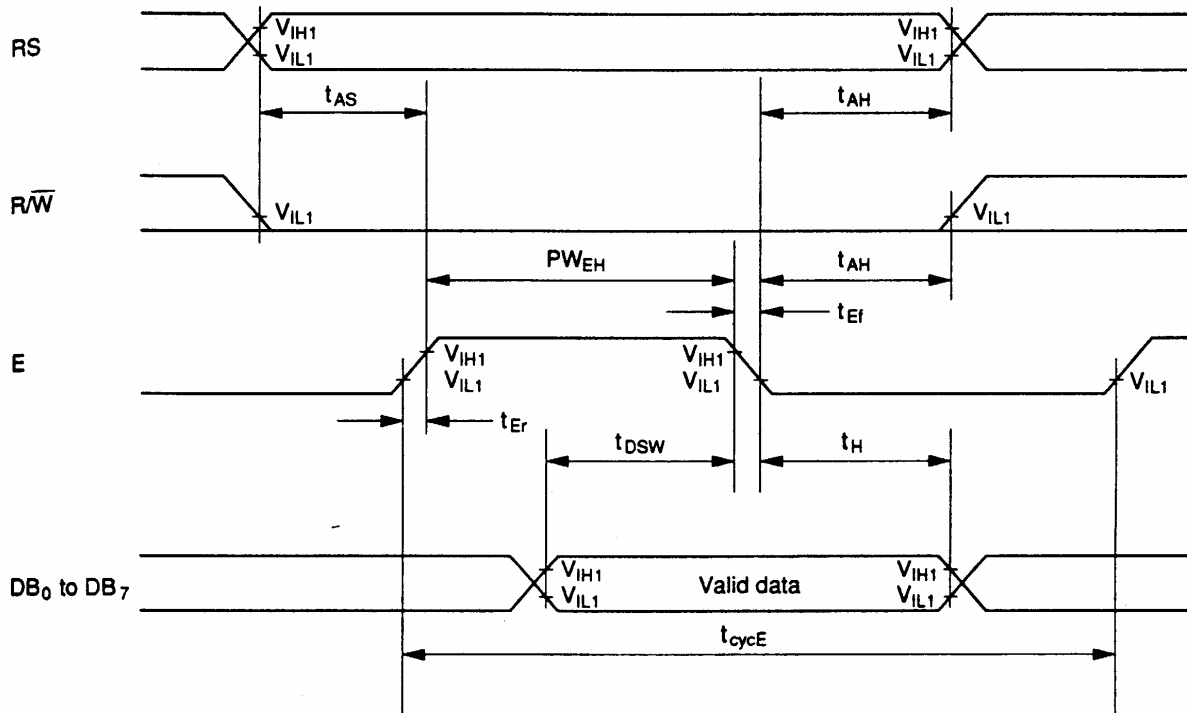

| Item | Symbol | VDD=5V | | VDD=3.3V | | Unit |
|---------------------------------------|----------------------------------|--------|-----|----------|-----|------|
| | | Min | Max | Min | Max | |
| Enable cycle time | t _{cycE} | 500 | -- | 1000 | -- | ns |
| Enable pulse width | P _{WEH} | 230 | -- | 450 | -- | |
| Enable rise/fall time | t _{Er} ,t _{Ef} | -- | 20 | -- | 25 | |
| Address set-up time (RS, R/W to E) | t _{AS} | 40 | -- | 60 | -- | |
| Address hold time | t _{AH} | 10 | -- | 20 | -- | |
| Data set-up time | t _{Dsw} | 80 | -- | 195 | -- | |
| Data hold time | t _H | 10 | -- | 10 | -- | |

Read Operation

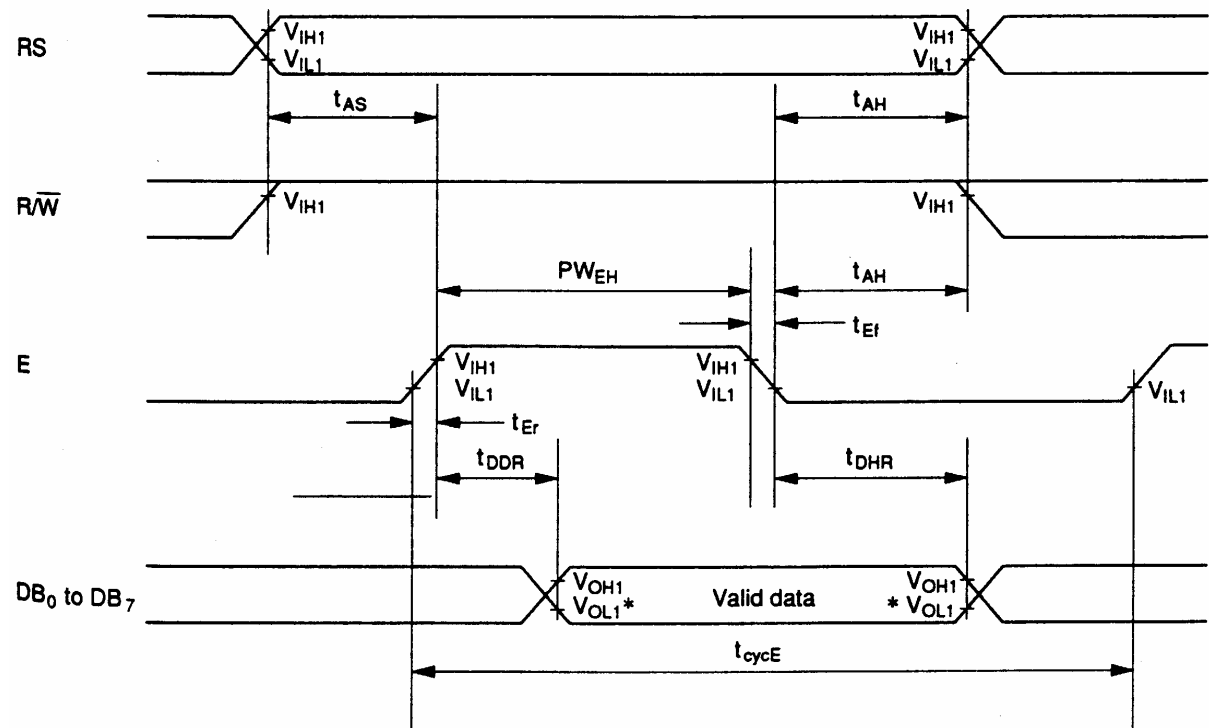

| Item | Symbol | VDD=5V | | VDD=3.3V | | Unit |
|---------------------------------------|------------------|--------|-----|----------|-----|------|
| | | Min | Max | Min | Max | |
| Enable cycle time | t_{cycE} | 500 | -- | 1000 | -- | ns |
| Enable pulse width | PW_{EH} | 230 | -- | 450 | -- | |
| Enable rise/fall time | t_{Er}, t_{Ef} | -- | 20 | -- | 25 | |
| Address set-up time (RS, R/W to E) | t_{AS} | 40 | -- | 60 | -- | |
| Address hold time | t_{AH} | 10 | -- | 20 | -- | |
| Data delay time | t_{DDR} | -- | 120 | -- | 360 | |
| Data hold time | t_{DRH} | 5 | -- | 5 | -- | |

9 INSTRUCTION SET

| Instruction | Code | | | | | | | | | | Description | E.T.(fosc =270 KHZ) |
|----------------------------|------|---------|----|---------|---------|---------|---------|---------|---------|---------|---|---------------------------|
| | RS | R/ W | D7 | D6 | D5 | D4 | D3 | D2 | D1 | D0 | | |
| Clear Display | 0 | 0 | 0 | 0 | 0 | 0 | 0 | 0 | 0 | 1 | Write"20H" to DDRAM and set DDRAM address to "00H" from AC | 1.53 ms |
| Return Home | 0 | 0 | 0 | 0 | 0 | 0 | 0 | 0 | 1 | -- | Sets DD RAM address to "00H" from AC and return cursor to its original position if shifted. The contents of DDRAM are not changed. | 1.53 ms |
| Entry Mode SET | 0 | 0 | 0 | 0 | 0 | 0 | 0 | 1 | I/D | SH | Assign cursor moving direction and enable the shift of entire display. | 39 μS |
| Display ON/OFF Control | 0 | 0 | 0 | 0 | 0 | 0 | 1 | D | C | B | Set display (D), cursor (C), and blink of cursor (B) on/off control bit. | 39 μS |
| Cursor or Display Shift | 0 | 0 | 0 | 0 | 0 | 1 | S/ C | R/ L | -- | -- | Set cursor moving and display shift control bit, and the direction, without changing of DDRAM data. | 39 μS |
| Function Set | 0 | 0 | 0 | 0 | 1 | DL | N | F | -- | -- | Sets interface data length (DL:8-bit/4-bit), number of display lines (N:2-line/1-line) and , display font type (F:5x11dots/5x8 dost). | 39 μS |
| Set CG RAM Address | 0 | 0 | 0 | 1 | AC 5 | AC 4 | AC 3 | AC 2 | AC 1 | AC 0 | Sets CG RAM address in address counter. | 39 μS |
| Set DD RAM Address | 0 | 0 | 1 | AC 6 | AC 5 | AC 4 | AC 3 | AC 2 | AC 1 | AC 0 | Sets DD RAM address in address counter. | 39 μS |
| Read Busy Flag and Address | 0 | 1 | BF | AC 6 | AC 5 | AC 4 | AC 3 | AC 2 | AC 1 | AC 0 | Whether during internal operation or not can be known by reading BF. The contents of address counter can also be read. | 0 μS |
| Write Data to RAM | 1 | 0 | D7 | D6 | D5 | D4 | D3 | D2 | D1 | D0 | Writes data into internal RAM (DD RAM /CG RAM). | 43 μS |
| Read Data from RAM | 1 | 1 | D7 | D6 | D5 | D4 | D3 | D2 | D1 | D0 | Reads data from internal RAM (DD RAM /CG RAM). | 43 μS |

* "--" : don't care

Note : When an MPU program with checking the Busy Flag(DB7) is made, it must be necessary 1/2Fosc is necessary for executing the next instruction by the falling edge of the 'E' signal after the Busy Flag(DB7) goes to "LOW".

10 INITIALIZATION SEQUENCE

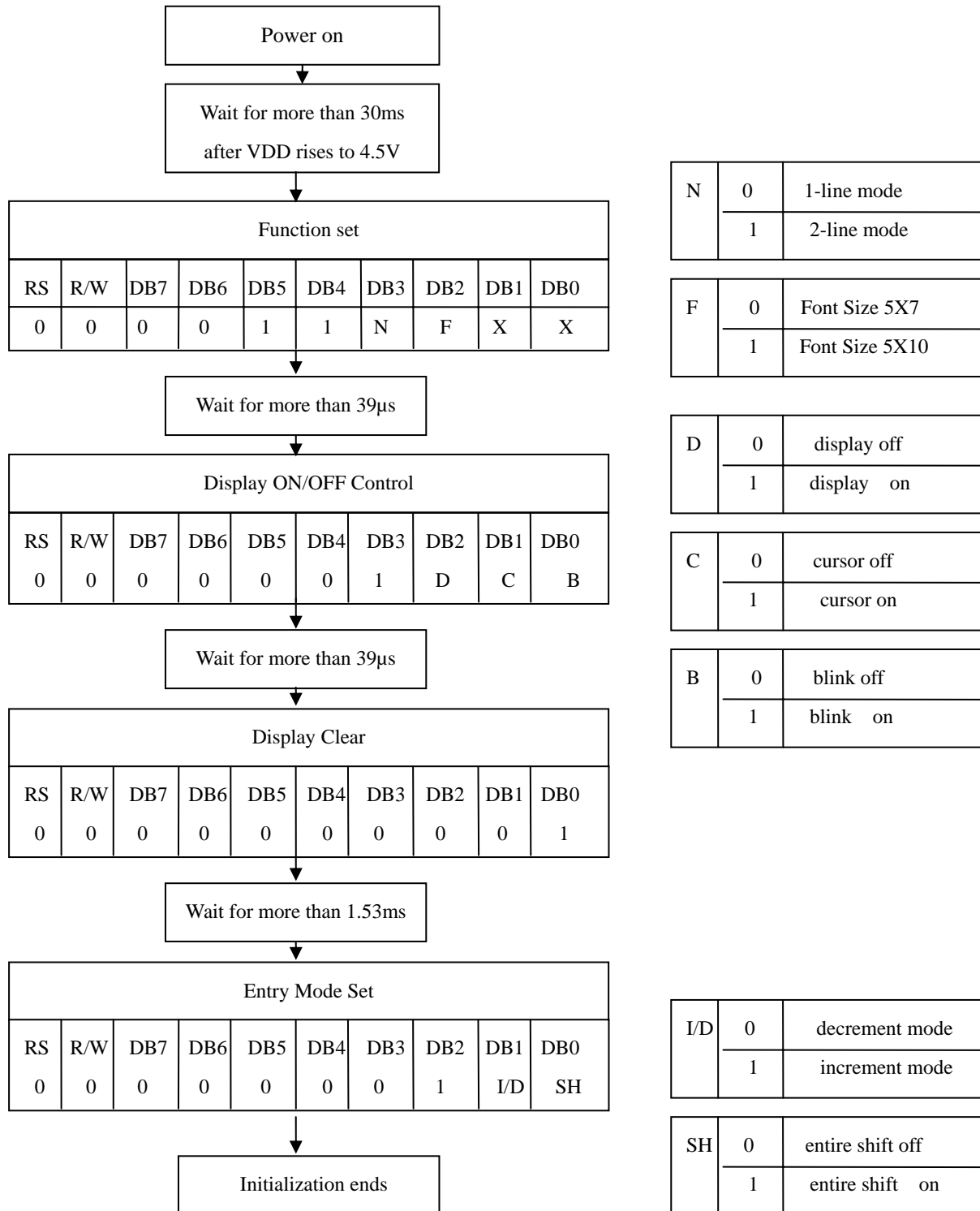

11 DD RAM ADDRESS

| | | | | | | | |
|--------|----|----|----|-----|----|----|----|
| CHAR. | 1 | 2 | 3 | ... | 38 | 39 | 40 |
| LINE 1 | 00 | 01 | 02 | ... | 25 | 26 | 27 |
| LINE 2 | 40 | 41 | 42 | ... | 65 | 66 | 67 |

12 FONT TABLE

| Upper 4bit Lower 4bit | | | | | | | | | | | | | | | | |
|--------------------------------|------------------|---------|---------|---------|---------|---------|---------|---------|---------|---------|---------|---------|---------|---------|---------|---------|
| | L.L.L.L | L.L.L.H | L.L.H.L | L.L.H.H | L.H.L.L | L.H.L.H | L.H.H.L | L.H.H.H | H.L.L.L | H.L.L.H | H.L.H.L | H.L.H.H | H.H.L.L | H.H.L.H | H.H.H.L | H.H.H.H |
| LLLL | CG RAM (1) | | | | | | | | | | | | | | | |
| LLLH | (2) | | | | | | | | | | | | | | | |
| LLHL | (3) | | | | | | | | | | | | | | | |
| LLHH | (4) | | | | | | | | | | | | | | | |
| LHLL | (5) | | | | | | | | | | | | | | | |
| LHLH | (6) | | | | | | | | | | | | | | | |
| LHHL | (7) | | | | | | | | | | | | | | | |
| LHHH | (8) | | | | | | | | | | | | | | | |
| HLLL | (1) | | | | | | | | | | | | | | | |
| HLLH | (2) | | | | | | | | | | | | | | | |
| HLHL | (3) | | | | | | | | | | | | | | | |
| HLHH | (4) | | | | | | | | | | | | | | | |
| HHLL | (5) | | | | | | | | | | | | | | | |
| HHLH | (6) | | | | | | | | | | | | | | | |
| HHHL | (7) | | | | | | | | | | | | | | | |
| HHHH | (8) | | | | | | | | | | | | | | | |

13 QUALITY AND RELIABILITY

13.1 TEST CONDITIONS

Tests should be conducted under the following conditions :

Ambient temperature : $25 \pm 5^{\circ}\text{C}$

Humidity : $60 \pm 25\% \text{ RH}$.

13.2 SAMPLING PLAN

Sampling method shall be in accordance with MIL-STD-105E, inspection level II, normal inspection, and single sampling plan tables for normal, tightened, and reduced inspection.

13.3 ACCEPTABLE QUALITY LEVEL

A major defect is defined as one that could cause failure to or materially reduce the usability of the unit for its intended purpose. A minor defect is one that does not materially reduce the usability of the unit for its intended purpose or is an infringement from established standards and has no significant bearing on its effective use or operation.

13.4 APPEARANCE

An appearance test should be conducted by human sight at approximately 30 cm distance from the LCD module under fluorescent light. The inspection area of LCD panel shall be within the range of following limits.

13.5 INSPECTION QUALITY CRITERIA

| Item | Description of defects | | | Class of Defects | Acceptable level (%) | |
|----------------------|--|-----------|-----------|------------------|----------------------|-----|
| Function | Short circuit or Pattern cut | | | Major | 0.65 | |
| Dimension | Deviation from drawings | | | Major | 1.5 | |
| Black spots | Ave . dia . D | area A | area B | Minor | 2.5 | |
| | $D \leq 0.2$ | Disregard | | | | |
| | $0.2 < D \leq 0.3$ | 3 | 4 | | | |
| | $0.3 < D \leq 0.4$ | 2 | 3 | | | |
| | $0.4 < D$ | 0 | 1 | | | |
| Black lines | Width W, Length L | | A | B | Minor | 2.5 |
| | $W \leq 0.03$ | | disregard | | | |
| | $0.03 < W \leq 0.05$ | | 3 | 4 | | |
| | $0.05 < W \leq 0.07, L \leq 3.0$ | | 1 | 1 | | |
| | See line criteria | | | | | |
| Bubbles in polarizer | Average diameter D $0.2 < D < 0.5$ mm for N = 4 , D > 0.5 for N = 1 | | | Minor | 2.5 | |
| Color uniformity | Rainbow color or newton ring. | | | Minor | 2.5 | |
| Glass Scratches | Obvious visible damage. | | | Minor | 2.5 | |
| Contrast ratio | See note 1 | | | Minor | 2.5 | |
| Response time | See note 2 | | | Minor | 2.5 | |
| Viewing angle | See note 3 | | | Minor | 2.5 | |

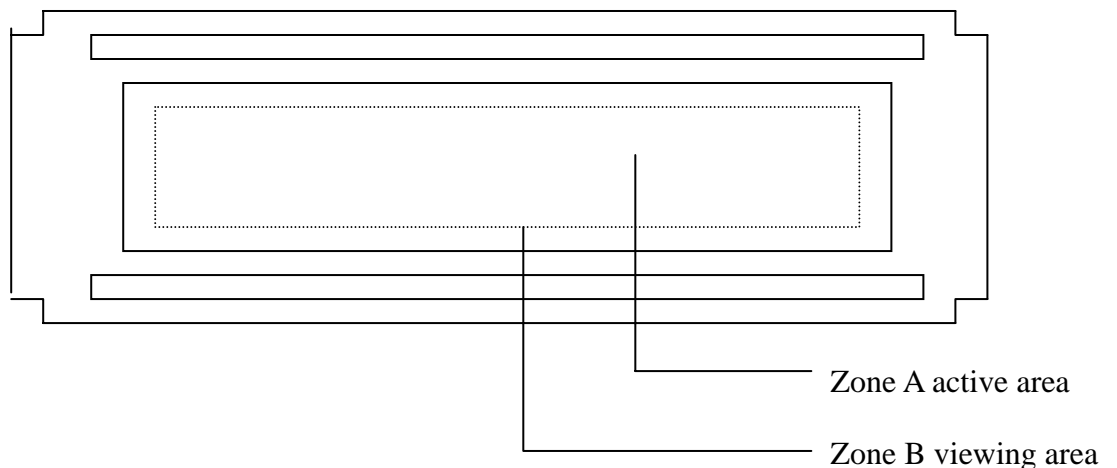

13.6 RELIABILITY

| Test Item | Test Conditions | Note |
|----------------------------|---|------|
| | Normal Temp. type | |
| High Temperature Operation | 50±3°C , t=96 hrs | |
| Low Temperature Operation | 0±3°C , t=96 hrs | |
| High Temperature Storage | 70±3°C , t=96 hrs | 1,2 |
| Low Temperature Storage | -20±3°C , t=96 hrs | 1,2 |
| Thermal Shock Test | -20°C ~ 25°C ~ 70°C 30 m in. 5 min. 30 min. (1 cycle) Total 5 cycle | 1,2 |
| Humidity Test | 40 °C, Humidity 90%, 96 hrs | 1,2 |
| Vibration Test (Packing) | Sweep frequency : 10 ~ 55 ~ 10 Hz/1min Amplitude : 0.75mm Test direction : X.Y.Z/3 axis Duration : 30min/each axis | 2 |

Note 1 : Condensation of water is not permitted on the module.

Note 2 : The module should be inspected after 1 hour storage in normal conditions (15-35°C , 45-65%RH).

Definitions of life end point :



- Current drain should be smaller than the specific value.
- Function of the module should be maintained.
- Appearance and display quality should not have degraded noticeably.
- Contrast ratio should be greater than 50% of the initial value.

14 HANDLING PRECAUTIONS

- (1) An LCD module is a fragile item and should not be subjected to strong mechanical shocks.
- (2) Avoid applying pressure to the module surface. This will distort the glass and cause a change in colour.
- (3) Under no circumstances should the position of the bezel tabs or their shape be modified.
- (4) Do not modify the display PCB in either shape or positioning of components.
- (5) Do not modify or move location of the zebra or heat seal connectors.
- (6) The device should only be soldered to during interfacing. Modification to other areas of the board should not be carried out.
- (7) In the event of LCD breakage and resultant leakage of fluid do not inhale, ingest or make contact with the skin. If contact is made rinse immediately.
- (8) When cleaning the module use a soft damp cloth with a mild solvent, such as Isopropyl or Ethyl alcohol. The use of water, ketone or aromatic is not permitted.
- (9) Prior to initial power up input signals should not be applied.
- (10) Protect the module against static electricity and observe appropriate anti-static precautions.

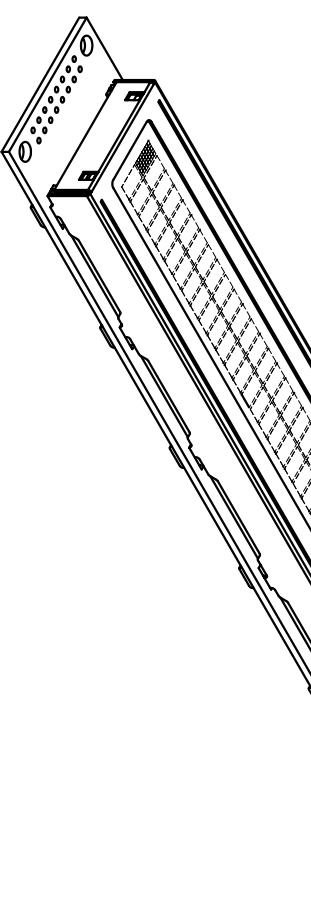
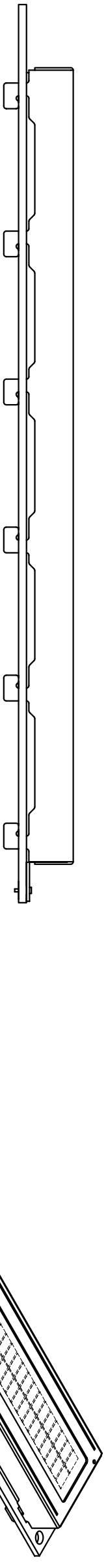
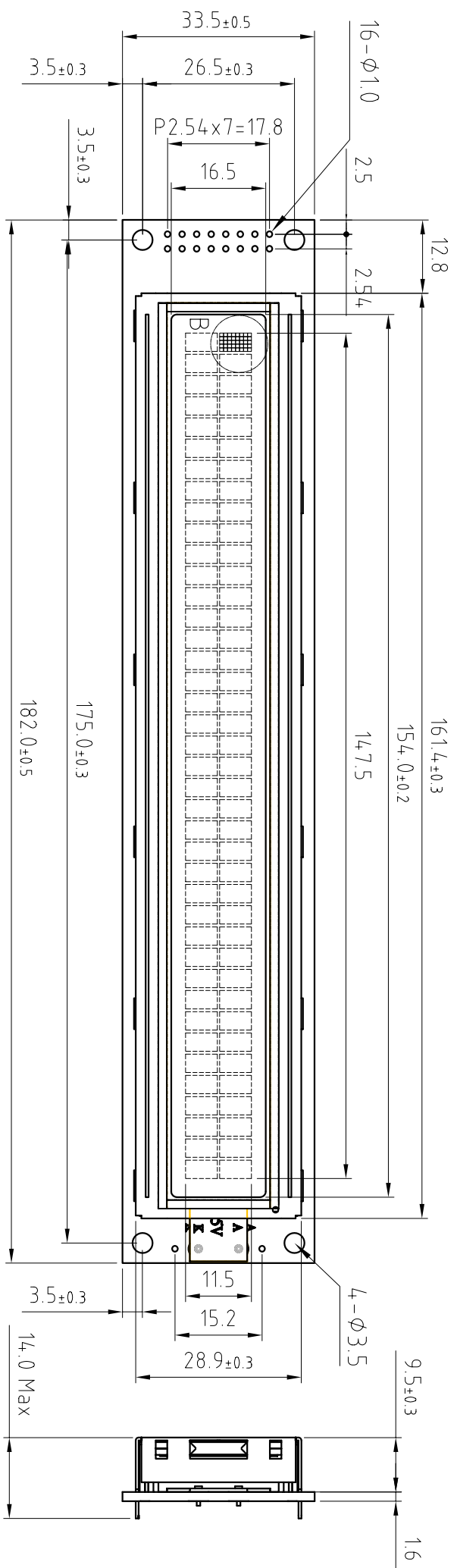
| INTERFACE | | | | | | | | | | | | | | | |
|-----------|-----|----|----|-----|---|-----|-----|-----|-----|-----|-----|-----|-----|-------|-------|
| 1 | 2 | 3 | 4 | 5 | 6 | 7 | 8 | 9 | 10 | 11 | 12 | 13 | 14 | 15 | 16 |
| VSS | VDD | V0 | RS | R/W | E | DB0 | DB1 | DB2 | DB3 | DB4 | DB5 | DB6 | DB7 | A/EL1 | K/EL2 |



| | | | | | | | | | | |
|--|--|----------------------|------------------------|------------------|--------------------|--|----------------------------|-------------------------|----------------------|---------------------------------|
|  APEX DISPLAY CO.,LTD. 晶英光電科技股份有限公司 | | Check By Drawn By | * <i>Burn Chang</i> | Approved By * | Date 2003/08/06 | Projection Type  | Scale 1:1 UNIT mm | Product No. AXSC402A | TITLE Outline DWG | Drawing NO. AXSC402A-0-02-01 |
|--|--|----------------------|------------------------|------------------|--------------------|--|----------------------------|-------------------------|----------------------|---------------------------------|