



AZ10LVEL16

AZ100LVEL16

ECL/PECL Differential Receiver

FEATURES

- 250ps Propagation Delay
- High Bandwidth Output Transitions
- Operating Range of 3.0V to 5.5V
- Internal Input Pulldown Resistors
- Direct Replacement For ON Semiconductor MC10EL16, MC100EL16, & MC100LVEL16

PACKAGE AVAILABILITY

PACKAGE	PART NUMBER	MARKING	NOTES
SOIC 8	AZ10LVEL16D	AZM10 LVEL16	1,2
SOIC 8	AZ100LVEL16D	AZM100 LVEL16	1,2
TSSOP 8	AZ10LVEL16T	AZT LV16	1,2
TSSOP 8 RoHS Compliant / Lead (Pb) Free	AZ10LVEL16T+	AZT+ LV16	1,2
TSSOP 8	AZ100LVEL16T	AZH LV16	1,2
TSSOP 8 RoHS Compliant / Lead (Pb) Free	AZ100LVEL16T+	AZH+ LV16	1,2

1 Add R1 at end of part number for 7 inch (1K parts), R2 for 13 inch (2.5K parts) Tape & Reel.

2 Date code format: "Y" or "YY" for year followed by "WW" for week on underside of part.

DESCRIPTION

The AZ10/100LVEL16 is a differential receiver. The device is functionally equivalent to the E116 device with higher performance capabilities. With output transition times significantly faster than the E116, the LVEL16 is ideally suited for interfacing with high frequency sources.

The LVEL16 provides a V_{BB} output for single-ended use or a DC bias reference for AC coupling to the device. For single-ended input applications, the V_{BB} reference should be connected to one side of the D/D differential input pair. The input signal is then fed to the other D/D input. The V_{BB} pin can support 1.5 mA sink/source current. When used, the V_{BB} pin should be bypassed to ground via a 0.01 μ F capacitor.

Under open input conditions internal input clamps will force the Q output LOW.

NOTE: Specifications in the ECL/PECL tables are valid when thermal equilibrium is established.

PIN DESCRIPTION

PIN	FUNCTION
D, D	Data Inputs
Q, Q	Data Outputs
V_{BB}	Reference Voltage Output
V_{CC}	Positive Supply
V_{EE}	Negative Supply
NC	No Connect

LOGIC DIAGRAM AND PINOUT ASSIGNMENT

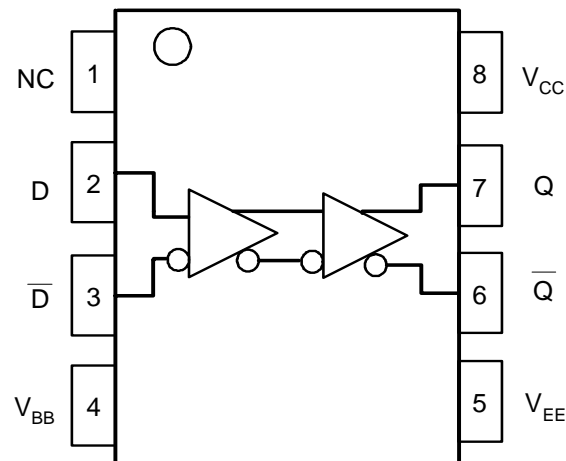

AZ10LVEL16
AZ100LVEL16

Absolute Maximum Ratings are those values beyond which device life may be impaired.

Symbol	Characteristic	Rating	Unit
V _{CC}	PECL Power Supply (V _{EE} = 0V)	0 to +8.0	Vdc
V _I	PECL Input Voltage (V _{EE} = 0V)	0 to +6.0	Vdc
V _{EE}	ECL Power Supply (V _{CC} = 0V)	-8.0 to 0	Vdc
V _I	ECL Input Voltage (V _{CC} = 0V)	-6.0 to 0	Vdc
I _{OUT}	Output Current --- Continuous --- Surge	50 100	mA
T _A	Operating Temperature Range	-40 to +85	°C
T _{STG}	Storage Temperature Range	-65 to +150	°C

10K ECL DC Characteristics (V_{EE} = -3.0V to -5.5V, V_{CC} = GND)

Symbol	Characteristic	-40°C			0°C			25°C			85°C			Unit
		Min	Typ	Max	Min	Typ	Max	Min	Typ	Max	Min	Typ	Max	
V _{OH}	Output HIGH Voltage ¹	-1080		-890	-1020		-840	-980		-810	-910		-720	mV
V _{OL}	Output LOW Voltage ¹	-1950		-1650	-1950		-1630	-1950		-1630	-1950		-1595	mV
V _{IH}	Input HIGH Voltage	-1230		-890	-1170		-840	-1130		-810	-1060		-720	mV
V _{IL}	Input LOW Voltage	-1950		-1500	-1950		-1480	-1950		-1480	-1950		-1445	mV
V _{BB}	Reference Voltage	-1430		-1300	-1380		-1270	-1350		-1250	-1310		-1190	mV
I _{IL}	Input LOW Current	-150			-150			-150			-150			μA
I _{IH}	Input HIGH Current			150			150			150			150	μA
I _{EE}	Power Supply Current		18	22		18	22		18	22		18	22	mA

- Each output is terminated through a 50Ω resistor to V_{CC} - 2V.

10K LVPECL DC Characteristics (V_{EE} = GND, V_{CC} = +3.3V)

Symbol	Characteristic	-40°C			0°C			25°C			85°C			Unit
		Min	Typ	Max	Min	Typ	Max	Min	Typ	Max	Min	Typ	Max	
V _{OH}	Output HIGH Voltage ^{1,2}	2220		2410	2280		2460	2320		2490	2390		2580	mV
V _{OL}	Output LOW Voltage ^{1,2}	1350		1650	1350		1670	1350		1670	1350		1705	mV
V _{IH}	Input HIGH Voltage ¹	2070		2410	2130		2460	2170		2490	2240		2580	mV
V _{IL}	Input LOW Voltage ¹	1350		1800	1350		1820	1350		1820	1350		1855	mV
V _{BB}	Reference Voltage ¹	1870		2000	1920		2030	1950		3050	1990		1390	mV
I _{IL}	Input LOW Current	-150			-150			-150			-150			μA
I _{IH}	Input HIGH Current			150			150			150			150	μA
I _{EE}	Power Supply Current		18	22		18	22		18	22		18	22	mA

- For supply voltages other than 3.3V, use the ECL table values and ADD supply voltage value.
- Each output is terminated through a 50Ω resistor to V_{CC} - 2V.

10K PECL DC Characteristics (V_{EE} = GND, V_{CC} = +5.0V)

Symbol	Characteristic	-40°C			0°C			25°C			85°C			Unit
		Min	Typ	Max	Min	Typ	Max	Min	Typ	Max	Min	Typ	Max	
V _{OH}	Output HIGH Voltage ^{1,2}	3920		4110	3980		4160	4020		4190	4090		4280	mV
V _{OL}	Output LOW Voltage ^{1,2}	3050		3350	3050		3370	3050		3370	3050		3405	mV
V _{IH}	Input HIGH Voltage ¹	3770		4110	3830		4160	3870		4190	3940		4280	mV
V _{IL}	Input LOW Voltage ¹	3050		3500	3050		3520	3050		3520	3050		3555	mV
V _{BB}	Reference Voltage ¹	3570		3700	3620		3730	3650		3750	3690		3810	mV
I _{IL}	Input LOW Current	-150			-150			-150			-150			μA
I _{IH}	Input HIGH Current			150			150			150			150	μA
I _{EE}	Power Supply Current		18	22		18	22		18	22		18	22	mA

- For supply voltages other than 5.0V, use the ECL table values and ADD supply voltage value.
- Each output is terminated through a 50Ω resistor to V_{CC} - 2V.

AZ10LVEL16

AZ100LVEL16

100K ECL DC Characteristics ($V_{EE} = -3.0V$ to $-5.5V$, $V_{CC} = GND$)

Symbol	Characteristic	-40°C			0°C			25°C			85°C			Unit
		Min	Typ	Max	Min	Typ	Max	Min	Typ	Max	Min	Typ	Max	
V_{OH}	Output HIGH Voltage ¹	-1085	-1005	-880	-1025	-955	-880	-1025	-955	-880	-1025	-955	-880	mV
V_{OL}	Output LOW Voltage ¹	-1830	-1695	-1555	-1810	-1705	-1620	-1810	-1705	-1620	-1810	-1705	-1620	mV
V_{IH}	Input HIGH Voltage	-1165		-880	-1165		-880	-1165		-880	-1165		-880	mV
V_{IL}	Input LOW Voltage	-1810		-1475	-1810		-1475	-1810		-1475	-1810		-1475	mV
V_{BB}	Reference Voltage	-1380		-1260	-1380		-1260	-1380		-1260	-1380		-1260	mV
I_{IL}	Input LOW Current	-150			-150			-150			-150			μA
I_{IH}	Input HIGH Current			150			150			150			150	μA
I_{EE}	Power Supply Current		18	22		18	22		18	22		18	24	mA

1. Each output is terminated through a 50Ω resistor to $V_{CC} - 2V$.

100K LVPECL DC Characteristics ($V_{EE} = GND$, $V_{CC} = +3.3V$)

Symbol	Characteristic	-40°C			0°C			25°C			85°C			Unit
		Min	Typ	Max	Min	Typ	Max	Min	Typ	Max	Min	Typ	Max	
V_{OH}	Output HIGH Voltage ^{1,2}	2215	2295	2420	2275	2345	2420	2275	2345	2420	2275	2345	2420	mV
V_{OL}	Output LOW Voltage ^{1,2}	1470	1605	1745	1490	1595	1680	1490	1595	1680	1490	1595	1680	mV
V_{IH}	Input HIGH Voltage ¹	2135		2420	2135		2420	2135		2420	2135		2420	mV
V_{IL}	Input LOW Voltage ¹	1490		1825	1490		1825	1490		1825	1490		1825	mV
V_{BB}	Reference Voltage ¹	1920		2040	1920		2040	1920		2040	1920		2040	mV
I_{IL}	Input LOW Current	-150			-150			-150			-150			μA
I_{IH}	Input HIGH Current			150			150			150			150	μA
I_{EE}	Power Supply Current		18	22		18	22		18	22		18	24	mA

1. For supply voltages other than 3.3V, use the ECL table values and ADD supply voltage value.

2. Each output is terminated through a 50Ω resistor to $V_{CC} - 2V$.

100K PECL DC Characteristics ($V_{EE} = GND$, $V_{CC} = +5.0V$)

Symbol	Characteristic	-40°C			0°C			25°C			85°C			Unit
		Min	Typ	Max	Min	Typ	Max	Min	Typ	Max	Min	Typ	Max	
V_{OH}	Output HIGH Voltage ^{1,2}	3915	3995	4120	3975	4045	4120	3975	4045	4120	3975	4045	4120	mV
V_{OL}	Output LOW Voltage ^{1,2}	3170	3305	3445	3190	3295	3380	3190	3295	3380	3190	3295	3380	mV
V_{IH}	Input HIGH Voltage ¹	3835		4120	3835		4120	3835		4120	3835		4120	mV
V_{IL}	Input LOW Voltage ¹	3190		3525	3190		3525	3190		3525	3190		3525	mV
V_{BB}	Reference Voltage ¹	3620		3740	3620		3740	3620		3740	3620		3740	mV
I_{IL}	Input LOW Current	-150			-150			-150			-150			μA
I_{IH}	Input HIGH Current			150			150			150			150	μA
I_{EE}	Power Supply Current		18	22		18	22		18	22		18	24	mA

1. For supply voltages other than 5.0V, use the ECL table values and ADD supply voltage value.

2. Each output is terminated through a 50Ω resistor to $V_{CC} - 2V$.

AC Characteristics ($V_{EE} = -3.0V$ to $-5.5V$; $V_{CC} = GND$ or $V_{EE} = GND$; $V_{CC} = +3.0V$ to $+5.5V$)

Symbol	Characteristic	-40°C			0°C			25°C			85°C			Unit
		Min	Typ	Max	Min	Typ	Max	Min	Typ	Max	Min	Typ	Max	
t_{PLH} / t_{PHL}	Propagation Delay to Output (Diff) (SE)	125	250	375	175	250	325	175	250	325	205	280	355	ps
		75	250	425	125	250	375	125	250	375	155	280	405	
t_{SKEW}	Duty Cycle Skew ¹ (Diff)		5			5	20		5	20		5	20	ps
$V_{PP}(AC)$	Minimum Input Swing ²	150			150			150			150			mV
V_{CMR}	Common Mode Range ³	$V_{EE} +$		$V_{CC} -$	$V_{EE} +$		$V_{CC} -$	$V_{EE} +$		$V_{CC} -$	$V_{EE} +$		$V_{CC} -$	V
		$V_{PP} < 500mV$	1.2	0.4	1.1	0.4	1.1	0.4	1.1	0.4	1.1	0.4		
		$V_{PP} \geq 500mV$	1.5	0.4	1.4	0.4	1.4	0.4	1.4	0.4	1.4	0.4		
t_r / t_f	Output Rise/Fall Times Q (20% - 80%)	100		260	100		260	100		260	100		260	ps

1. Duty cycle skew is the difference between a t_{PLH} and t_{PHL} propagation delay through a device.

2. V_{PP} is the minimum peak-to-peak differential input swing for which AC parameters are guaranteed. The device has a DC gain of ≈ 40 .

3. The V_{CMR} range is referenced to the most positive side of the differential input signal. Normal operation is obtained if the HIGH level falls within the specified range and the peak-to-peak voltage lies between $V_{PP}(\min)$ and 1V.

**PACKAGE DIAGRAM
SOIC 8**

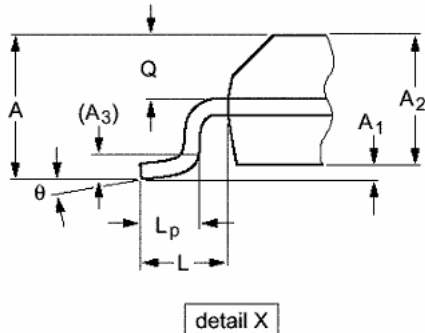
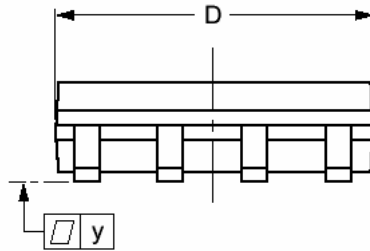
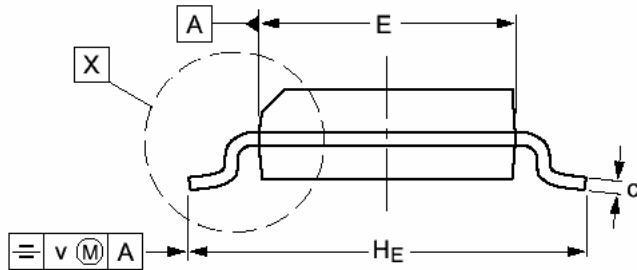
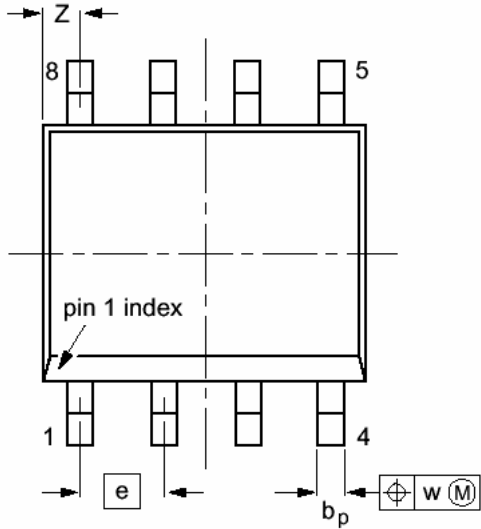

DIM	MILLIMETERS		INCHES	
	MIN	MAX	MIN	MAX
A		1.75	0.069	
A ₁	0.10	0.25	0.004	0.010
A ₂	1.25	1.45	0.049	0.057
A ₃	0.25		0.01	
b _p	0.36	0.49	0.014	0.019
c	0.19	0.25	0.0075	0.0100
D	4.8	5.0	0.19	0.20
E	3.8	4.0	0.15	0.16
e	1.27		0.050	
H _E	5.80	6.20	0.228	0.244
L	1.05		0.041	
L _p	0.40	1.00	0.016	0.039
Q	0.60	0.70	0.024	0.028
v	0.25		0.01	
w	0.25		0.01	
y	0.10		0.004	
Z	0.30	0.70	0.012	0.028
θ	0°	8°	0°	8°

- NOTES:
1. DIMENSIONS D AND E DO NOT INCLUDE MOLD PROTRUSION.
 2. MAXIMUM MOLD PROTRUSION FOR D IS 0.15mm.
 3. MAXIMUM MOLD PROTRUSION FOR E IS 0.25mm.

**PACKAGE DIAGRAM
TSSOP 8**

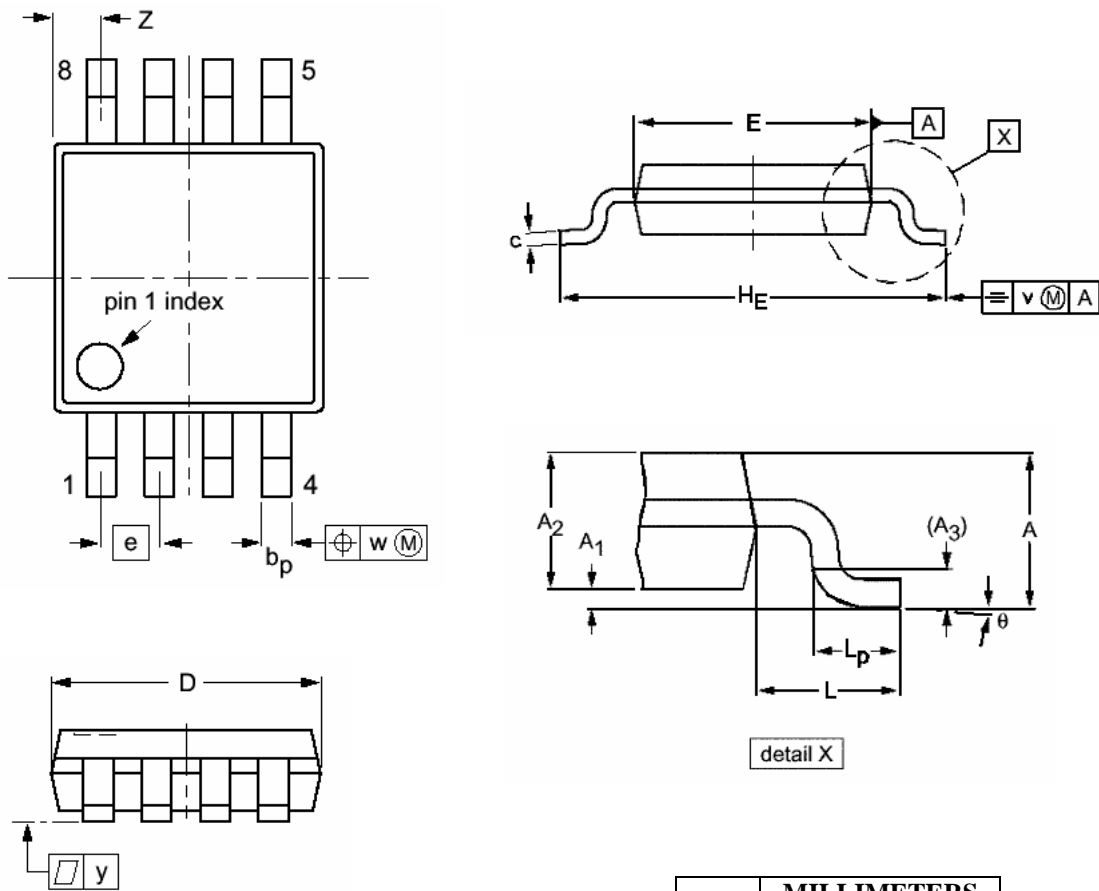

NOTES:

1. DIMENSIONS D AND E DO NOT INCLUDE MOLD PROTRUSION.
2. MAXIMUM MOLD PROTRUSION FOR D IS 0.15mm.
3. MAXIMUM MOLD PROTRUSION FOR E IS 0.25mm.

DIM	MILLIMETERS	
	MIN	MAX
A		1.10
A₁	0.05	0.15
A₂	0.80	0.95
A₃	0.25	
b_p	0.25	0.45
c	0.15	0.28
D	2.90	3.10
E	2.90	3.10
e	0.65	
H_E	4.70	5.10
L	0.94	
L_p	0.40	0.70
v	0.10	
w	0.10	
y	0.10	
Z	0.35	0.70
θ	0°	6°

AZ10LVEL16
AZ100LVEL16

Arizona Microtek, Inc. reserves the right to change circuitry and specifications at any time without prior notice. Arizona Microtek, Inc. makes no warranty, representation or guarantee regarding the suitability of its products for any particular purpose, nor does Arizona Microtek, Inc. assume any liability arising out of the application or use of any product or circuit and specifically disclaims any and all liability, including without limitation special, consequential or incidental damages. Arizona Microtek, Inc. does not convey any license rights nor the rights of others. Arizona Microtek, Inc. products are not designed, intended or authorized for use as components in systems intended to support or sustain life, or for any other application in which the failure of the Arizona Microtek, Inc. product could create a situation where personal injury or death may occur. Should Buyer purchase or use Arizona Microtek, Inc. products for any such unintended or unauthorized application, Buyer shall indemnify and hold Arizona Microtek, Inc. and its officers, employees, subsidiaries, affiliates, and distributors harmless against all claims, costs, damages, and expenses, and reasonable attorney fees arising out of, directly or indirectly, any claim of personal injury or death associated with such unintended or unauthorized use, even if such claim alleges that Arizona Microtek, Inc. was negligent regarding the design or manufacture of the part.