

Service
Service
Service



Service Manual

CONTENTS

Technical specification and disassemble diagram	1
Service and safety instructions	2
Block diagram	3-1
Wiring diagram	4-1
Main+Radio+Rectifier board	
Circuit diagram	5-1, 5-3
Layout diagram	5-4, 5-5
Display board	
Circuit diagram	6-1
Layout diagram	6-2
Exploded view diagram	7-1
Revision list	8-1



© Copyright 2011 Philips Consumer Electronics B.V. Eindhoven, The Netherlands
All rights reserved. No part of this publication may be reproduced, stored in a retrieval system or transmitted, in any form or by any means, electronic, mechanical, photocopying, or otherwise without the prior permission of Philips.



GENERAL DESCRIPTION
 CDSM with Tuner , CD, USB
 Aux In, Headphone

LIFETIME : 5 Years

Class	Tuner	Supply + Amplifier	Loudspeaker Boxes	Recorder	USB	CD
I	XX				XX	
II						
III						

SAFETY requirements

Refer to the section of Version Overview

RADIATION / IMMUNITY requirements (EMC)

Refer to the section of Version Overview

CLIMATIC requirements

ALL climates : - 10 Degree till + 50 Degree

PERFORMANCE CLASSES

POWER SUPPLY

MAINS (A.C.)	120/230Vac ± 15%	230 Vac ± 10 %	120V +/- 15%	220V-10%,240+10%	99-146V, 196-264Vac
Version	97 / 98	12	96	73	55 / 77 / 78
Voltage Selection	Yes	No	No	No	Yes
Frequency	60 / 50Hz	50 Hz	60 Hz	50 Hz	60 / 50Hz

DC operation / Backup Buffer

Battery type : R20 (UM1 / D-cell) x 6 (9V normal, 6.3V limit)

POWER CONSUMER

	MAINS (A.C.)	DC operation / Backup Buffer
Standby : (DEMO mode " OFF ") , NOM. A. INPUT		
Maximum : @ 1/8 Prated , NOM. A. INPUT	14W	
ECO Power mode :	N/A	

Remarks :

GENERAL PART 1 - GENERAL SPECIFICATION

Class No	AZ3811			Issued Date
				1/11/2011
				1/11/2011
2011-01-11				
NAME : Mo Lam Kei		8	SH 190 - 4	A4
KT	CHECK	CM	T	

TECHNIAL DESCRIPTION

2 x 2W matching LOUDSPEAKER of 2 x 8R. One INPUT SOURCE

GENERAL PART

OUTPUT stage Protection : Yes Temperature : YES Shorcircuit : Yes

INDICATORS

Standby Mode Indicator : LCD display off

ECO Mode Indicator : NA

ELECTRICAL DATA

DSC :	NA			
DBB	Yes	Hum (Volume Minimun)	0.5	uW
SIS :	N/A	Residual Noise (Volume Minimun)	0.06	uW
VAC :	N/A			
WOOX :	N/A			

INTERCONNECTS

Input Sensitivity (± 33) rated ouput power at 1 kHz

Line Output Voltage (*1)

Tuner	FM 67.5KHZ,AM80% Modulation(Limit :-6db)	Line Out (Left / Right)	N.A
CD	-6 dB track (Audio Disc 1 ,Trk 35)	Subwoofer Out	N.A
USB	-6 dB track (Copy from Audio Disc 1 ,Trk 35)	Headphone	15 mW - 2 dB , at R Load = 32 ohm @ max volume, 0dB, 1kHz CD
AUX	500mV	Digital Coaxial Out	N.A
Microphone	-6 dB track (Audio Disc 1 ,Trk 35)	Booster Out	N.A

OUTPUT POWER (* 1)

At (THD = 10% , 1kHz sinewave

Main Operation	: 2.5W, 1 Channels (Lim: -1dB)	(At Cold Condition with 10% THD)
DC Operation	: .25W, 1 Channels (Lim: -1dB)	
Frequency Response	: 125Hz - 14kHz	(At 500mW Output in flat Mode)

LOUDSPEAKER (BOXES)

Rated Impedance

Left / Right 8 Ohms at 125Hz to 16kHz

Remarks

(*1) Electrical parameters are to be measurement at specker terminals across 8 Ohm load (pure resistor) with rated input signal in AUX mode; with DBB OFF

GENERAL PART 1 - TECHNICAL SPECIFICATION

Class No	AZ3811	Issued Date		
		1/11/2011		
		1/11/2011		
2011-01-11				
NAME : Mo Lam Kei		8	SH 190 - 5	A4
KT	CHECK	CM	T	

TECHNICAL DESCRIPTION

CLOCK PART

Timer Setting	:	NA
Timer Wakeup Mode	:	NA
Remarks Time Setting	:	NA
Volume at Wakeup	:	NA
No of Timer Settings	:	NA
Clock Accuracy	:	NA

INDICATORS

Display Type	:	LCD
--------------	---	-----

CD PART

Channel Unbalance (250 to 10k Hz)	:	≤ 3dB
Frequency Response(±3dB) (@ volume max - 20dB and DBB off mode)	:	100Hz~10kHz
Signal to Noise Ratio(A-weighted)	:	62dBA(Lim 57 dBA)
THD (1kHz)	:	1.5%(Lim 2.0%)
THD (100 ~10kHz)	:	2%(Lim 3.0%)
Channel Separation(1K)	:	40dB(Lim 26dB)
Channel Separation(10K)	:	30dB(Lim 16dB)
CD Shock sens.	:	5kg

USB PART

- Refer to Philips USB direct user requirement spec.



DBB effect

DBB	:	8~2 dB at A/BX 500mV, 1kHz
-----	---	----------------------------

CLOCK / CD SPECIFICATION

Class No	AZ3811				Issued Date
					1/11/2011
					1/11/2011
2011-01-11					
NAME : Mo Lam Kei		8	SH 190 - 6		A4
KT	CHECK	CM	T		

TECHNICAL DESCRIPTION

GENERAL PART

WAVE RANGE

FM	Refer to version overview
AM	Refer to version overview
MW	Refer to version overview

AERIAL

FM : Telescope
AM/MW : Ferrite

INDICATORS : NA

ELECTRICAL DATA

A.M	Nom	Limit	Unit	F.M.	Nom	Limit	Unit
IF	450	± 3	kHz	IF	10.7	± 0.3	MHz
AGC figure of merit	30	25	dB	3dB Limiting Point	17	25	dBf
Distortion (RF 50mV, m=80%)	35		%	Distortion (RF 1mV, Freq Dev.75 kHz)	3	5%	
				Stereo -46 dB Quieting	48	51	dBf
				FM S/N Ratio(A weighted) Mono input 80dBf	55	50	dB
Modulation Hum	45	40	dB	Modulation Hum	45	40	dB
				FM Channel Separation -400/KS/5K	21/25/18	18/20/15	dB
Search tuning sensitivity	48 - 72		dBuV/m	Search tuning sensitivity	24-32	19 - 35	dBf
Search tuning stop accuracy RF >= 1V/m RF >= a26 to 1V/m		+/- 1 0		Search Tuning Stop Accuracy RF: 91 - 120dBf RF-31/-91dBf		+/- 1 0	Step
Search Time		60	Sec.	Search Time		60	Sec.

Wave Range	Noise Limited Sensitivity (26 dB)	Image Rejection	IF Rejection	Large Signal
FM	Nom.	28	24	130dBf
	Lim.	22	20	125dBf
AM / MW	Nom.	64	32	120 dBuV/m
	Lim.	72	28	114 dBuV/m
			dB	dB

Remarks

TUNER SPECIFICATION

Class No	AZ3811	Issued Date		
		1/11/2011		
		1/11/2011		
2011-01-11				
NAME : Mo Lam Kei		8	SH 190 - 7	A4
KT	CHECK	CMT		

1、 Disassemble bottom cabinet

1a

disassemble six 3 x 12 PB screws from the top cabinet



1b

disassemble two 3 x 8 PB screws on bottom cabinet



1c

remove the bottom cabinet and unplug the 2pin cable between Main BD and power BD

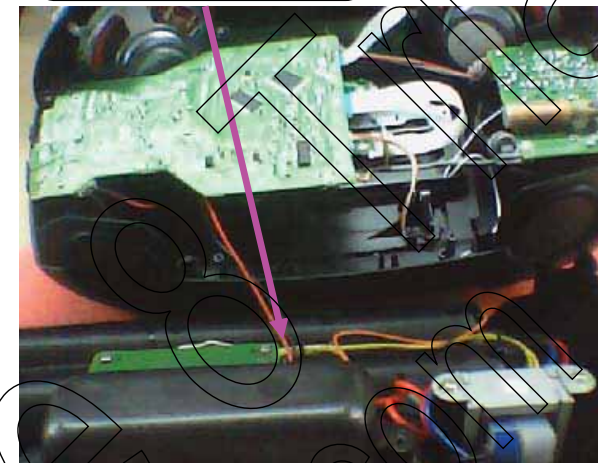

2、 Disassemble front cabinet

2a

disassemble the four 3 x 8 PB screws which connect top cabinet and front cabinet



2b

unplug 4pin speaker cable and 10pin FFC cable



2c

separate top cabinet and front cabinet



3A、 Disassemble Main BD

3-a

disassemble the five 2.6 x 8 PB screws on Main BD

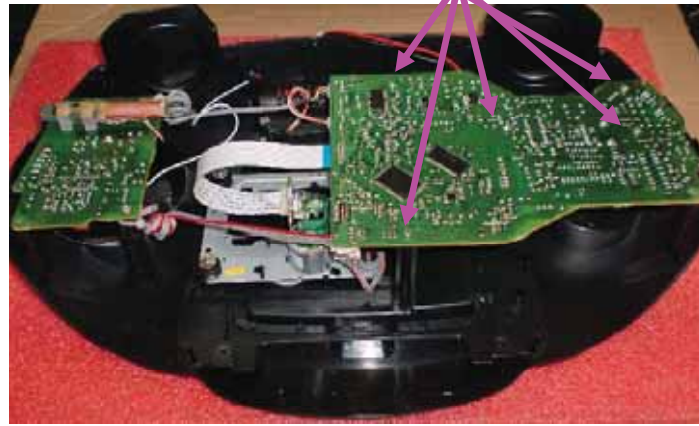

3-b

unplug the 4pin cable, 2pin open-close cable, 4pin cable to radio BD and 6pin cable to CD Deck on Main BD



3-c

remove volumn knob and get out Main BD

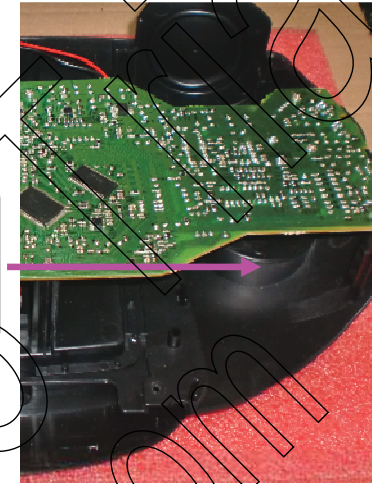

3B、 Disassemble radio BD and CD deck

3-d

disassemble the two 2.6 x 8 PB screws on radio BD, unplug FM ANT cable

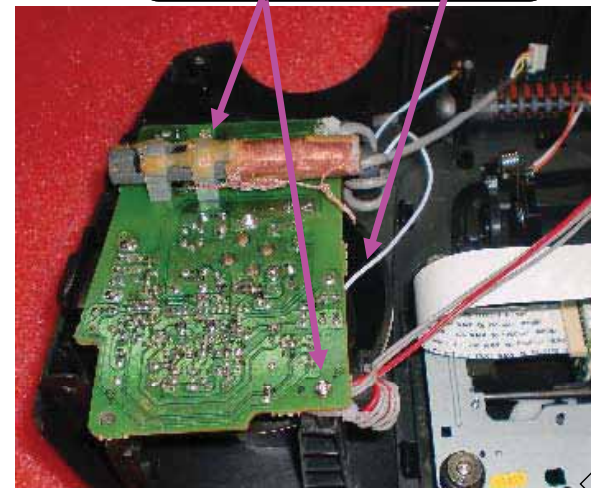

3-e

unplug tuning knob and get out the radio BD



3-f

disassemble the four 2.6 x 8 PWA screws on CD deck and get out CD deck



3C、 Disassemble CD door

3-g

take out CD door spring first



pull out CD door when going the CD door buckle with a screwdriver



PDF Create & Trial
www.nuance.com

MEASUREMENT SETUP

Tuner FM

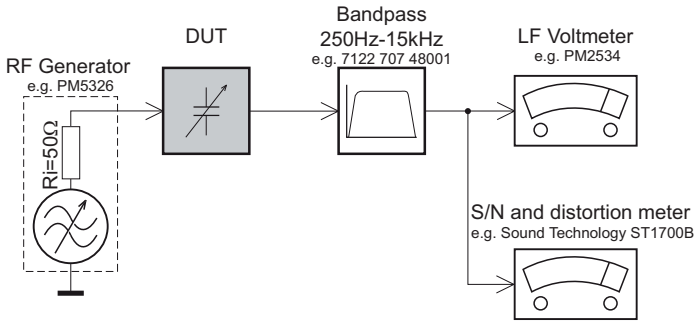

Use a bandpass filter to eliminate hum (50Hz, 100Hz) and disturbance from the pilotone (19kHz, 38kHz).

Tuner AM (MW,LW)

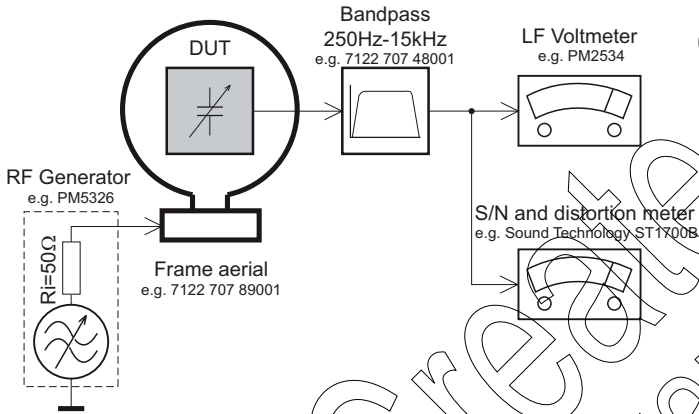

To avoid atmospheric interference all AM-measurements have to be carried out in a Faraday's cage. Use a bandpass filter (or at least a high pass filter with 250Hz) to eliminate hum (50Hz, 100Hz).

CD

Use Audio Signal Disc SBC429 4822 397 30184 (replaces test disc 3)

Recorder

Use Universal Test Cassette Cr02 SBC419 4822 397 30069 or Universal Test Cassette Fe SBC420 4822 397 30071

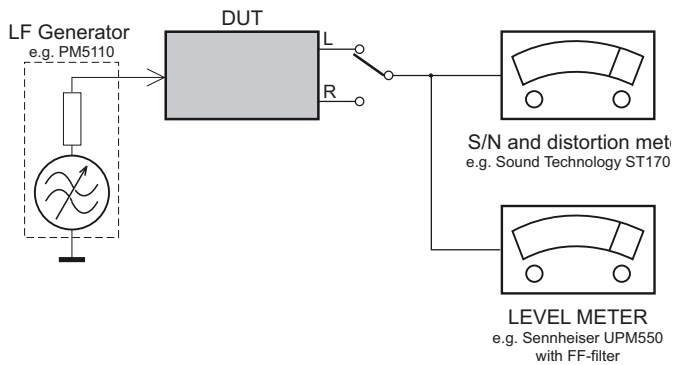
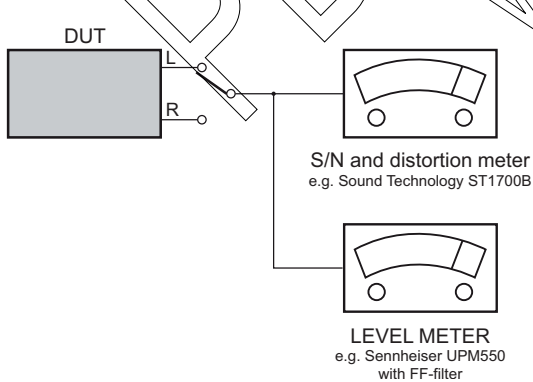

INSTRUCTIONS ON CD PLAYABILITY

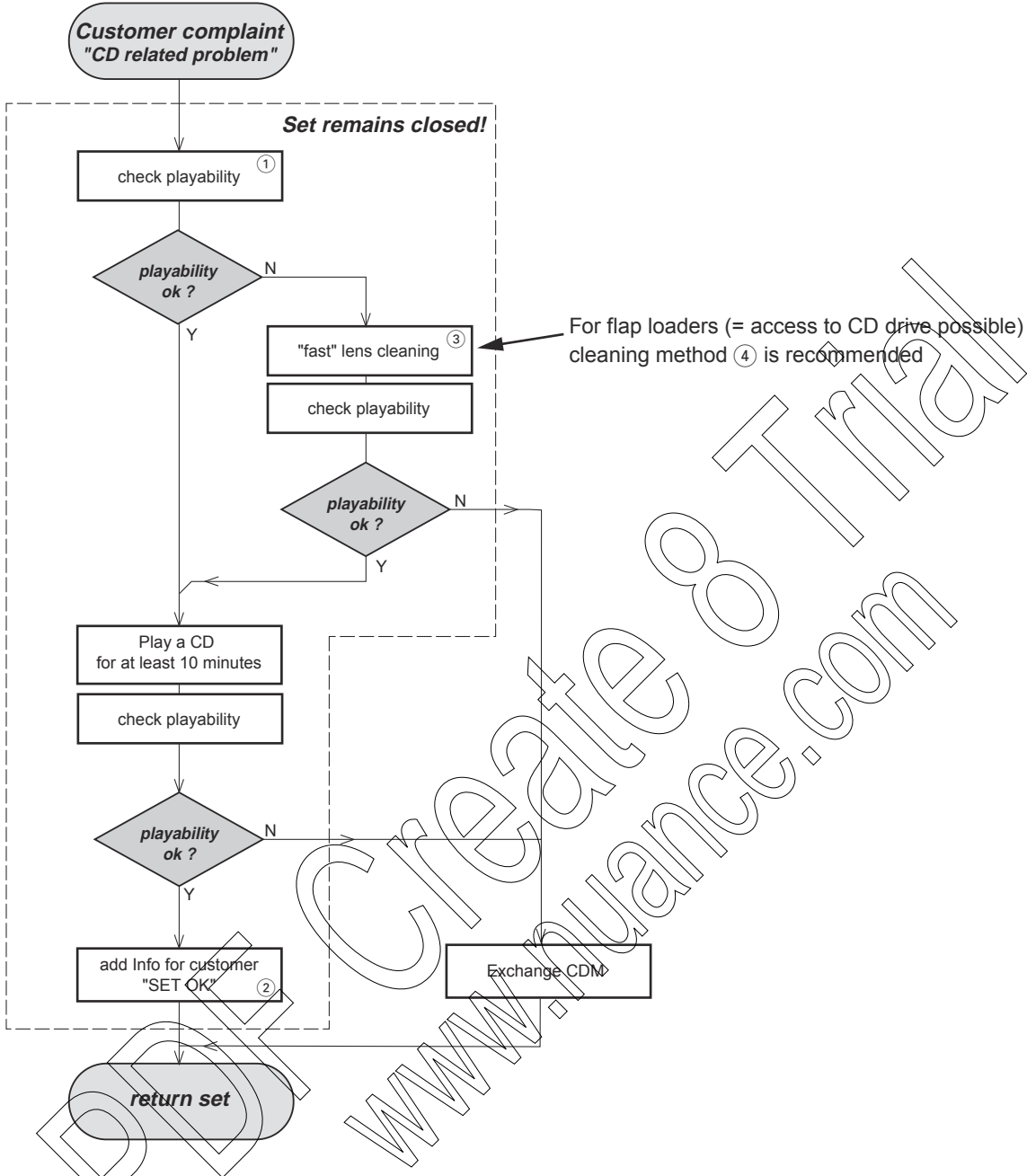

For flap loaders (= access to CD drive possible) cleaning method ④ is recommended

① - ④ For description - see following pages

INSTRUCTIONS ON CD PLAYABILITY

①

PLAYABILITY CHECK

For sets which are compatible with **CD-RW** discs
 use CD-RW Printed Audio Disc7104 099 96611
 TR 3 (Fingerprint)
 TR 8 (600µ Black dot) **maximum at 01:00**

- playback of these two tracks without audible disturbance
 playing time for: Fingerprint ≥ 10 seconds
 Black dot from 00:50 to 01:10
- jump forward/backward (search) within a reasonable time

For all other sets
 use CD-DA SBC 444A4822 397 30245
 TR 14 (600µ Black dot) **maximum at 01:15**
 TR 19 (Fingerprint)
 TR 10 (1000µ wedge)

- playback of all these tracks without audible disturbance
 playing time for: 1000µ wedge ≥ 10 seconds
 Fingerprint ≥ 10 seconds
 Black dot from 01:05 to 01:25
- jump forward/backward (search) within a reasonable time

②

CUSTOMER INFORMATION

It is proposed to add an addendum sheet to the set which informs the customer that the set has been checked carefully - but no fault was found.

The problem was obviously caused by a scratched, dirty or copy-protected CD. In case problems remain, the customer is requested to contact the workshop directly.

The lens cleaning (method ③) should be mentioned in the addendum sheet.

The final wording in national language as well as the printing is under responsibility of the Regional Service Organizations.

④

LIQUID LENS CLEANING

Before touching the lens it is advised to clean the surface of the lens by blowing clean air over it. This to avoid that little particles make scratches on the lens.

Because the material of the lens is synthetic and coated with a special anti-reflectivity layer, cleaning must be done with a non-aggressive cleaning fluid. It is advised to use "Cleaning Solvent".

The actuator is a very precise mechanical component and may not be damaged in order to guarantee its full function. Clean the lens gently (don't press too hard) with a soft and clean cotton bud moistened with the special lens cleaner.

The direction of cleaning must be in the way as indicated in the picture below.



2.0 SAFETY INSTRUCTIONS

(GB) WARNING

All ICs and many other semi-conductors are susceptible to electrostatic discharges (ESD). Careless handling during repair can reduce life drastically. When repairing, make sure that you are connected with the same potential as the mass of the set via a wrist wrap with resistance. Keep components and tools also at this potential.

(F) ATTENTION

Tous les IC et beaucoup d'autres semi-conducteurs sont sensibles aux décharges statiques (ESD). Leur longévité pourrait être considérablement écourtée par le fait qu'aucune précaution n'est prise à leur manipulation. Lors de réparations, s'assurer de bien être relié au même potentiel que la masse de l'appareil et enfiler le bracelet serti d'une résistance de sécurité. Veiller à ce que les composants ainsi que les outils que l'on utilise soient également à ce potentiel.

(D) WARNUNG

Alle ICs und viele andere Halbleiter sind empfindlich gegenüber elektrostatischen Entladungen (ESD). Unsorgfältige Behandlung im Reparaturfall kann die Lebensdauer drastisch reduzieren. Veranlassen Sie, dass Sie im Reparaturfall über ein Pulsarmband mit Widerstand verbunden sind mit dem gleichen Potential wie die Masse des Gerätes. Bauteile und Hilfsmittel auch auf dieses gleiche Potential halten.

(NL) WAARSCHUWING

Alle IC's en vele andere halfgeleiders zijn gevoelig voor electrostatische ontladingen (ESD). Onzorgvuldig behandelen tijdens reparatie kan de levensduur drastisch doen verminderen. Zorg ervoor dat u tijdens reparatie via een polsband met weerstand verbonden bent met hetzelfde potentiaal als de massa van het apparaat. Houd componenten en hulpmiddelen ook op ditzelfde potentiaal.

(I) AVVERTIMENTO

Tutti IC e parecchi semi-conduttori sono sensibili alle scariche statiche (ESD). La loro longevità potrebbe essere fortemente ridotta in caso di non osservazione della più grande cauzione alla loro manipolazione. Durante le riparazioni occorre quindi essere collegato allo stesso potenziale che quello della massa dell'apparecchio tramite un braccialetto a resistenza. Assicurarsi che i componenti e anche gli utensili con quali si lavora siano anche a questo potenziale.

(GB)

Safety regulations require that the set be restored to its original condition and that parts which are identical with those specified, be used.

*Pour votre sécurité, ces documents doivent être utilisés par des spécialistes agréés, seuls habilités à réparer votre appareil en panne.

(NL)

Veiligheidsbepalingen vereisen, dat het apparaat bij reparatie in zijn oorspronkelijke toestand wordt teruggebracht en dat onderdelen, identiek aan de gespecificeerde, worden toegepast.

(F)

Les normes de sécurité exigent que l'appareil soit remis à l'état d'origine et que soient utilisées les pièces de rechange identiques à celles spécifiées.

(D)

Bei jeder Reparatur sind die geltenden Sicherheitsvorschriften zu beachten. Der Originalzustand des Geräts darf nicht verändert werden; für Reparaturen sind Original-Ersatzteile zu verwenden.

(I)

Le norme di sicurezza esigono che l'apparecchio venga rimesso nelle condizioni originali e che siano utilizzati i pezzi di ricambio identici a quelli specificati.

"After servicing and before returning set to customer perform a leakage current measurement test from all exposed metal parts to earth ground to assure no shock hazard exist. The leakage current must not exceed 0.5mA."

Caution: These servicing instructions are for use by qualified service personnel only.

To reduce the risk of electric shock do not perform any servicing other than that contained in the operating instructions unless you are qualified to do so.

ESD

**(GB)** Warning !

Invisible laser radiation when open. Avoid direct exposure to beam.

(S) Varning !

Osynlig laserstrålning när apparaten är öppnad och spärren är urkopplad. Betrakta ej strålen.

(SF) Varoitus !

Avatussa laitteessa ja suojalukituksen ohitettaessa olet alttiina näkymättömälle laserisäteilylle. Älä katso säteeseen!

DK Advarse !

Usynlig laserstrålning ved åbning når sikkerhedsafbrydere er ude af funktion. Undgå udsættelse for stråling.

2.1 ESD PROTECTION

- レンズには絶対に触れないでください。
- DO NOT TOUCH THE LENS.
- LINSE NICHT BRÜHREN.
- NE PAS TOUCHER LA LENTILLE.

When the power supply is being turned on, you may not remove this laser cautions label. If it removes, radiation of laser may be received.

PREPARATION OF SERVICING

Pickup Head consists of a laser diode that is very susceptible to external static electricity.

Although it operates properly after replacement, if it was subject to electrostatic discharge during replacement, its life might be shortened. When replacing, use a conductive mat, soldering iron with ground wire, etc. to protect the laser diode from damage by static electricity.

And also, the LSI and IC are same as above.

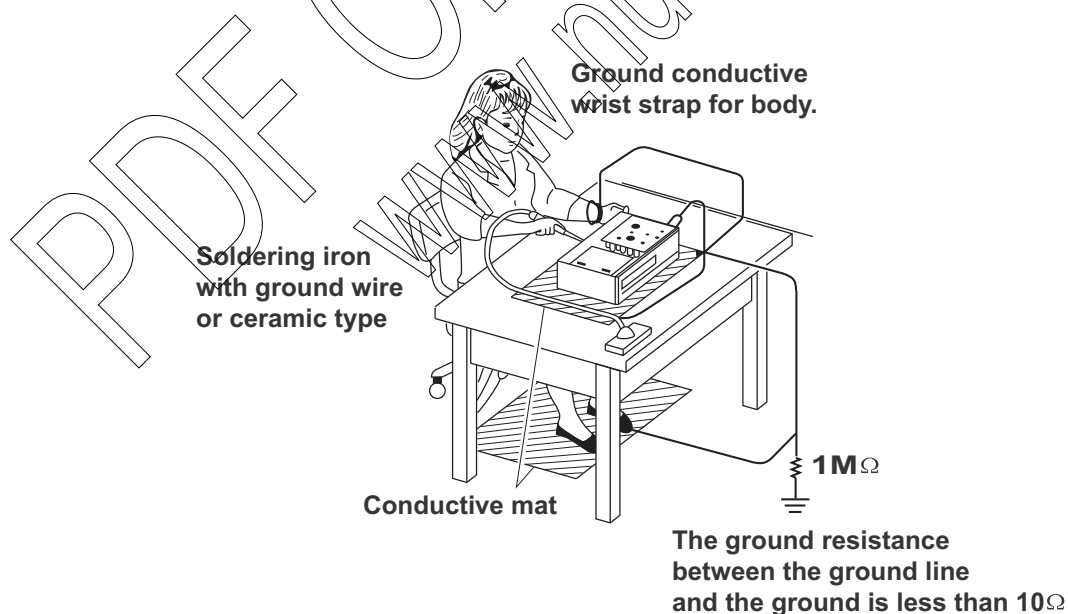

SAFTY NOTICE

SAFTY PRECAUTIONS

LEAKAGE CURRENT CHECK

Plug the AC line cord directly into a 120V AC outlet (do not use an isolation transformer for this check). Use an AC voltmeter, having 5000Ω per volt or more sensitivity. Connect a 1500Ω 10W resistor, paralleled by a $0.15\mu\text{F}$ 150V AC capacitor between a known good earth ground (water pipe, conduit, etc.) and all exposed metal parts of cabinet (antennas, handle bracket, metal cabinet screwheads, metal overlays, control shafts, etc.).

Measure the AC voltage across the 1500Ω resistor. The test must be conducted with the AC switch on and then repeated with the AC switch off. The AC voltage indicated by the meter may not exceed 0.3V. A reading exceeding 0.3V indicates that a dangerous potential exists, the fault must be located and corrected. Repeat the above test with the DVD VIDEO PLAYER power plug reversed. NEVER RETURN A DVD VIDEO PLAYER TO THE CUSTOMER WITHOUT TAKING NECESSARY CORRECTIVE ACTION.

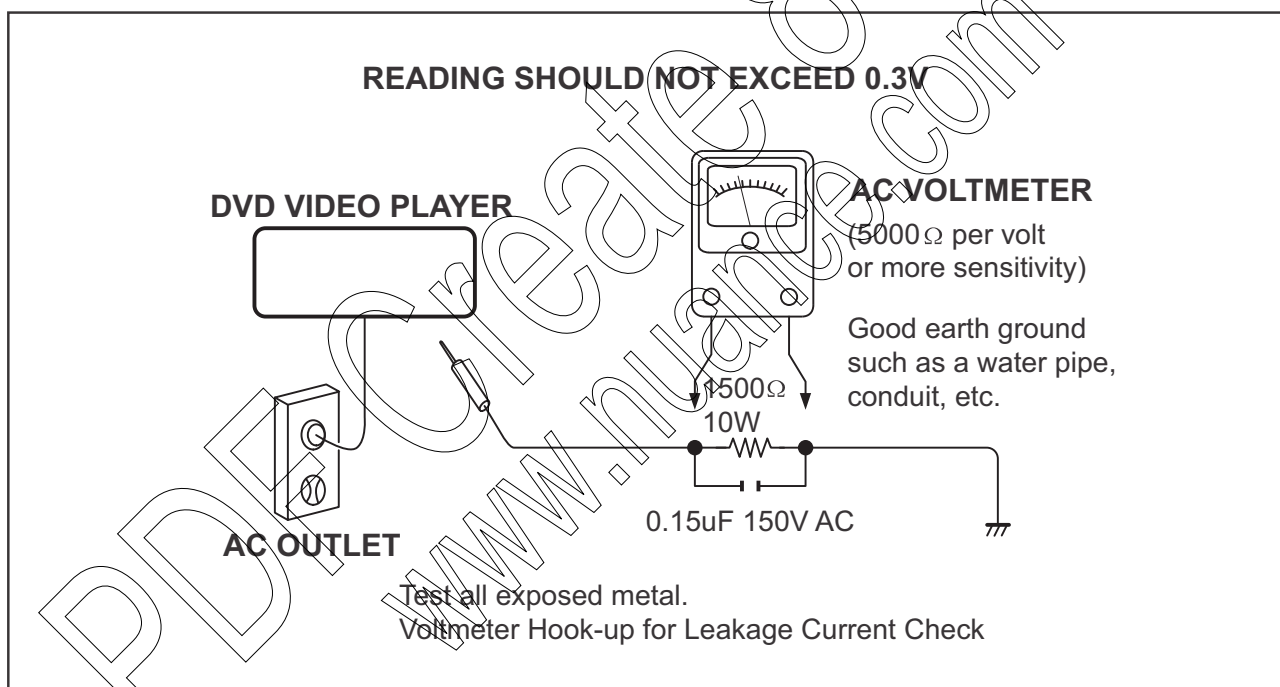

The lightning flash with arrowhead symbol, within an equilateral triangle, is intended to alert the user to the presence of uninsulated "dangerous voltage" within the product's enclosure that may be of sufficient magnitude to constitute a risk of electric shock to persons.



The exclamation point within an equilateral triangle is intended to alert the user to the presence of important operating and maintenance (servicing) instructions in the literature accompanying the appliance.

2.2 SAFETY INSTRUCTIONS

Battery Handling Guideline

Since the battery is packed in soft package, to ensure its better performance, it's very important to carefully handle the battery

2.2.1 Soft Aluminium foil

The soft aluminum packing foil is very easily damaged by sharp edge parts such as Ni-tabs, pins and needles.

- Don't strike battery with any sharp edge parts
- Trim your nail or wear glove before taking battery
- Clean worktable to make sure no any sharp particle



2.2.2 Sealed edge

Sealing edge is very flimsy

- Don't bend or fold sealing edge



2.2.3 Folding edge

The folding edge is form in battery process and passed all hermetic test.

- Don't open or deform folding edge



2.2.4 Tabs

The battery tabs are not so stubborn especially for aluminum tab.

- Don't bend tab



2.2.5 Mechanical shock

- Don't Fall, hit, bend battery body



2.2.6 Short

Short terminals of battery is strictly prohibited, it may damage battery.

Caution: Danger of explosion if battery is incorrectly replaced.
Replace only with the same or equivalent type.

SET BLOCK DIAGRAM

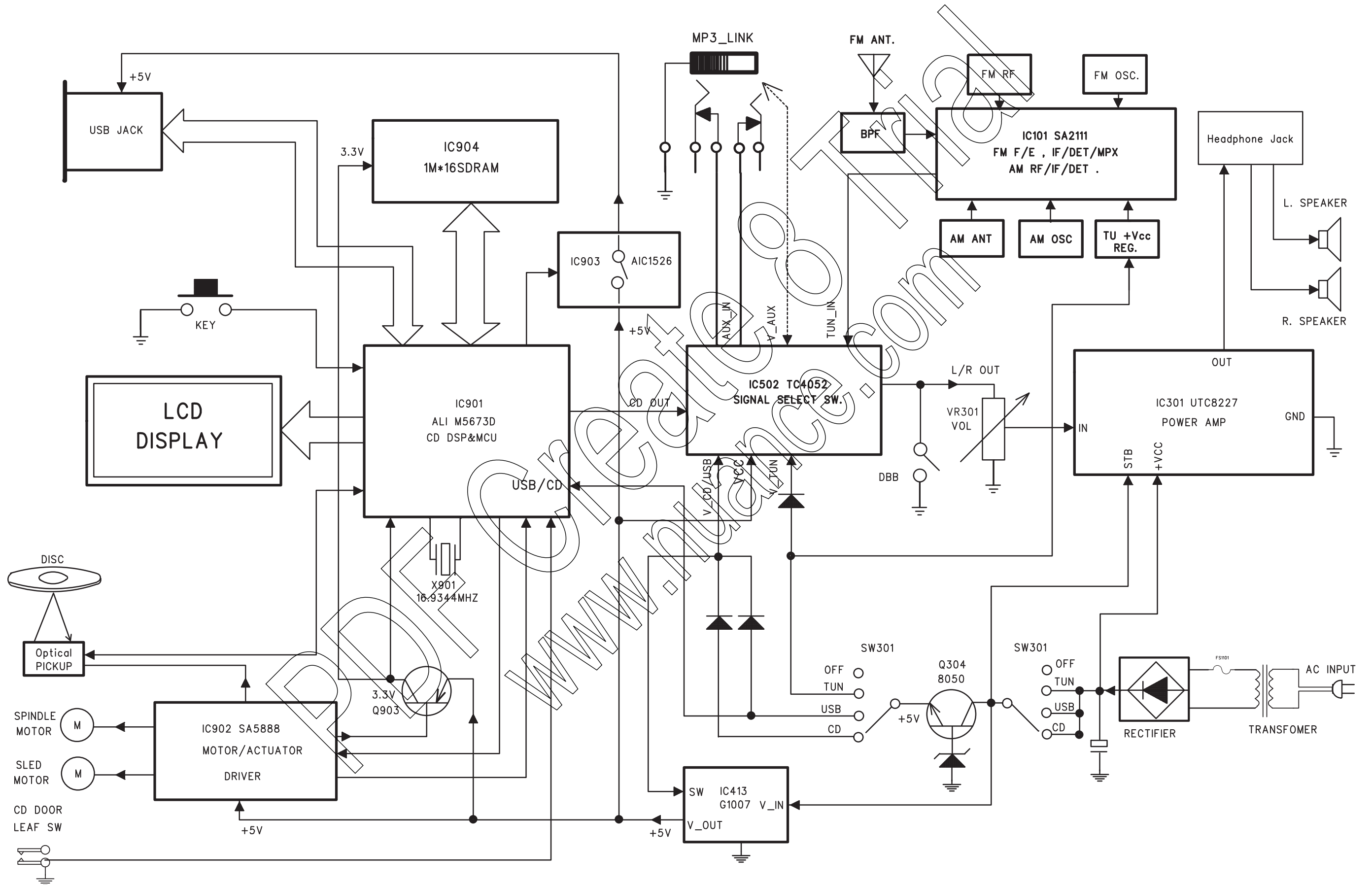

CIRCUIT DIAGRAM - MAIN/RADIO/RECTIFIER BOARD RAIDO/RECTIFIER/MAIN BOARD-PART1

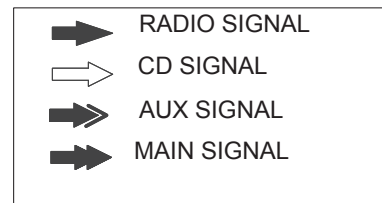
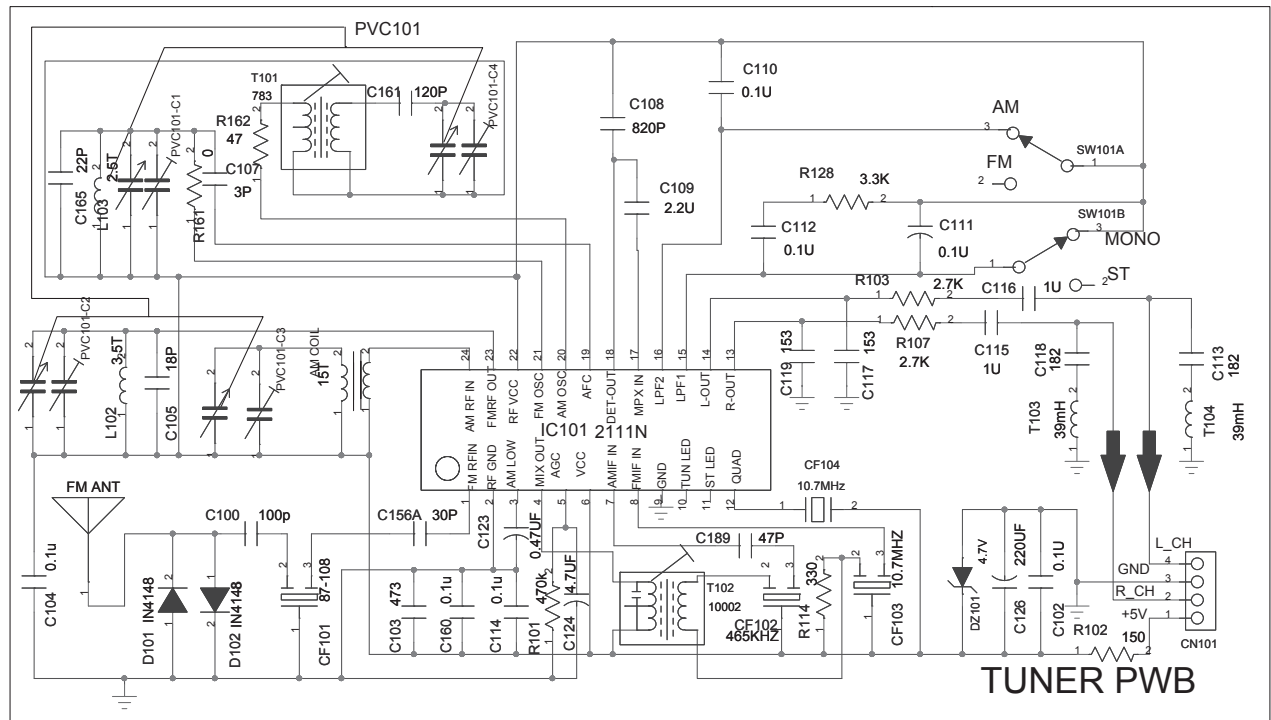

1. DISCONNECT POWER CORD BEFORE SERVING
2. RECOMMEND THE UNIT BE OPERATED BY DC 12V VOLTS DURING TROUBLE SHOOTING
3. COMPONENTS MARKED WITH HAVE CRITICAL CHARACTERISTICS ONLY REPLACE WITH THE COMPONENT OF THE SAME TYPE NUMBER.
4. SUBJECT TO CHANGE WITHOUT NOTICE

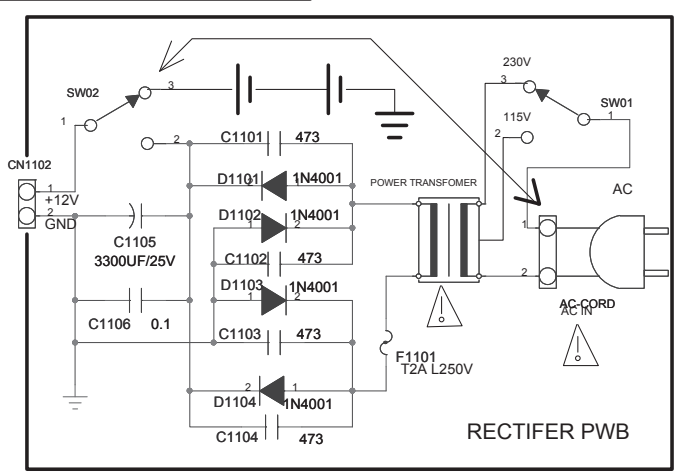
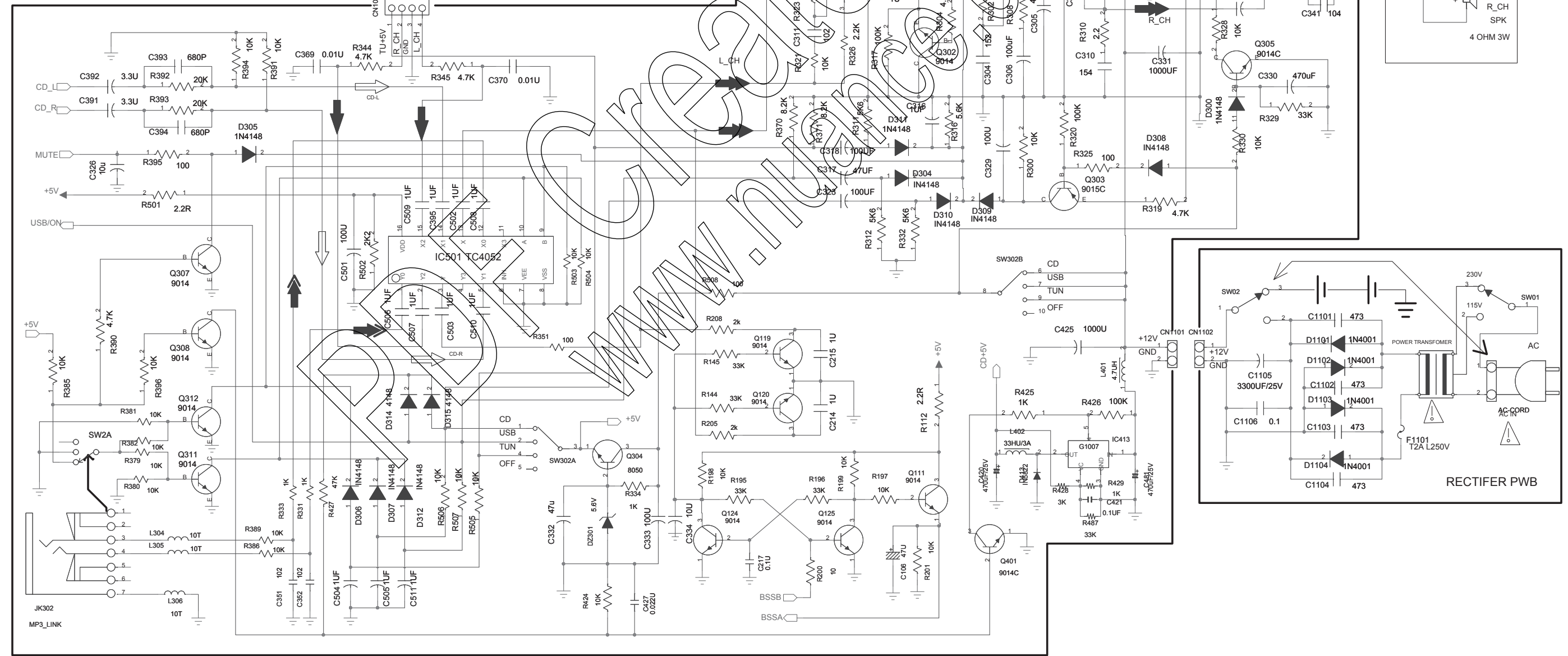

CIRCUIT DIAGRAM - MAIN/RADIO/RECTIFIER BOARD MAIN BOARD-PART2

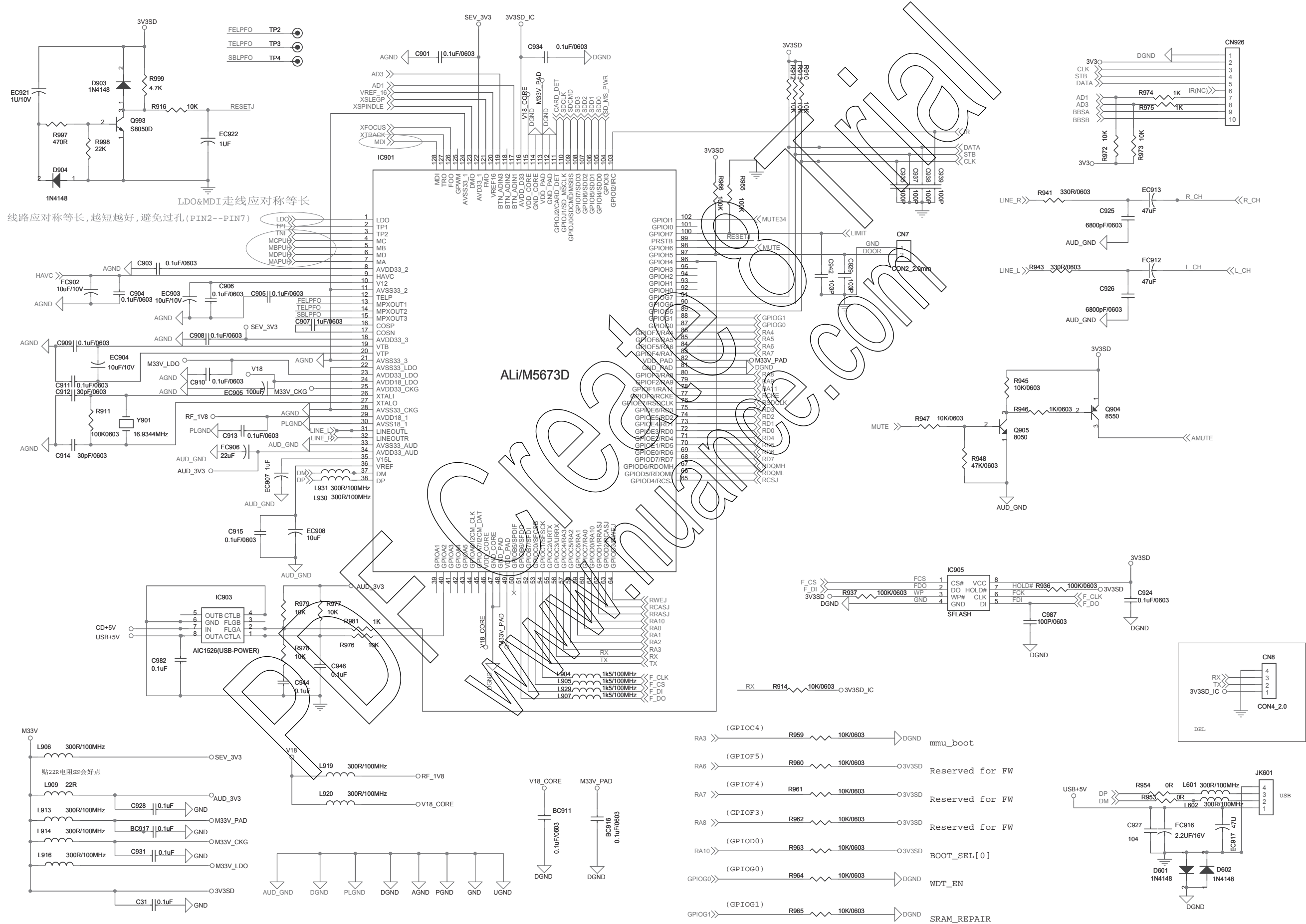

CIRCUIT DIAGRAM - MAIN/RADIO/RECTIFIER BOARD MAIN BOARD-PART3

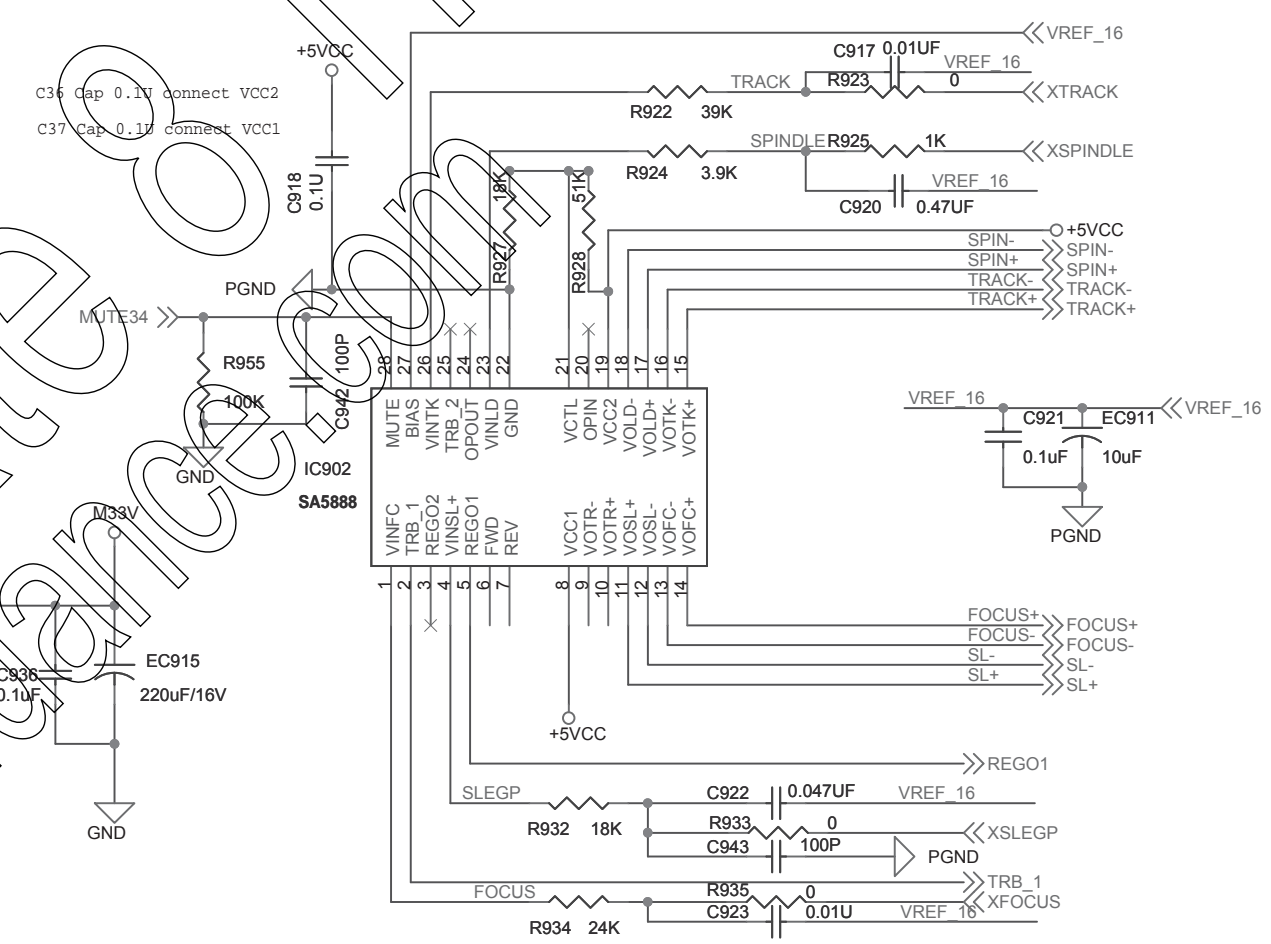
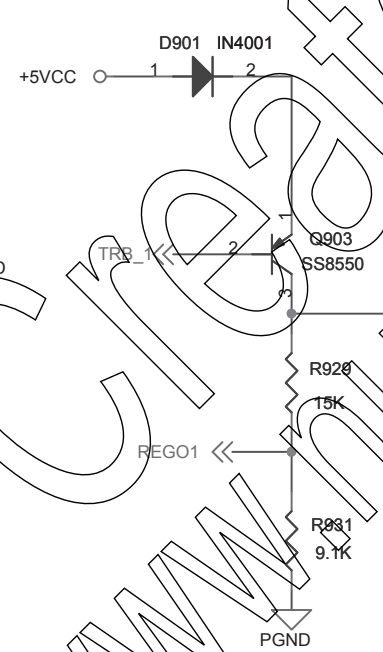
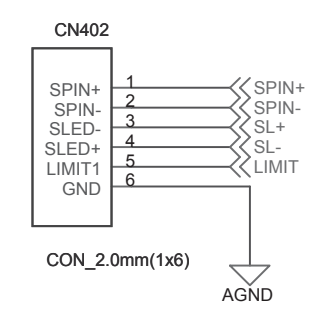
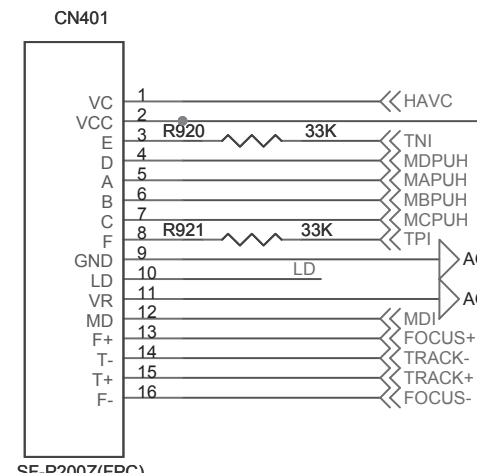
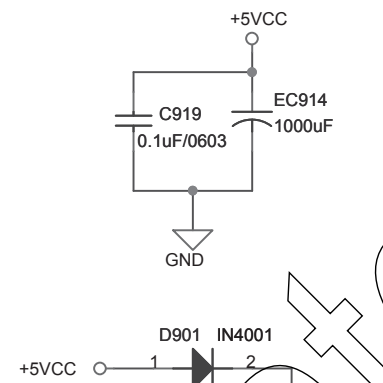
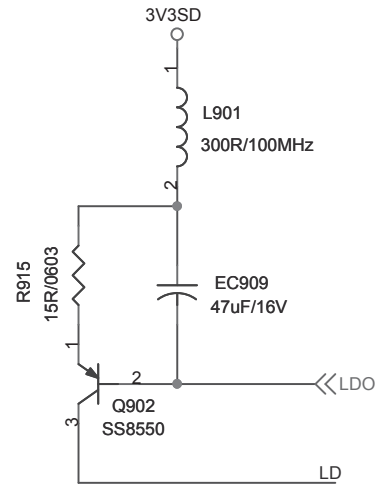

PDF
www.mnanc.com
8 Trial

LAYOUT DIAGARM - MAIN/RADIO/RECTIFIER BOARD
TOP SIDE VIEW

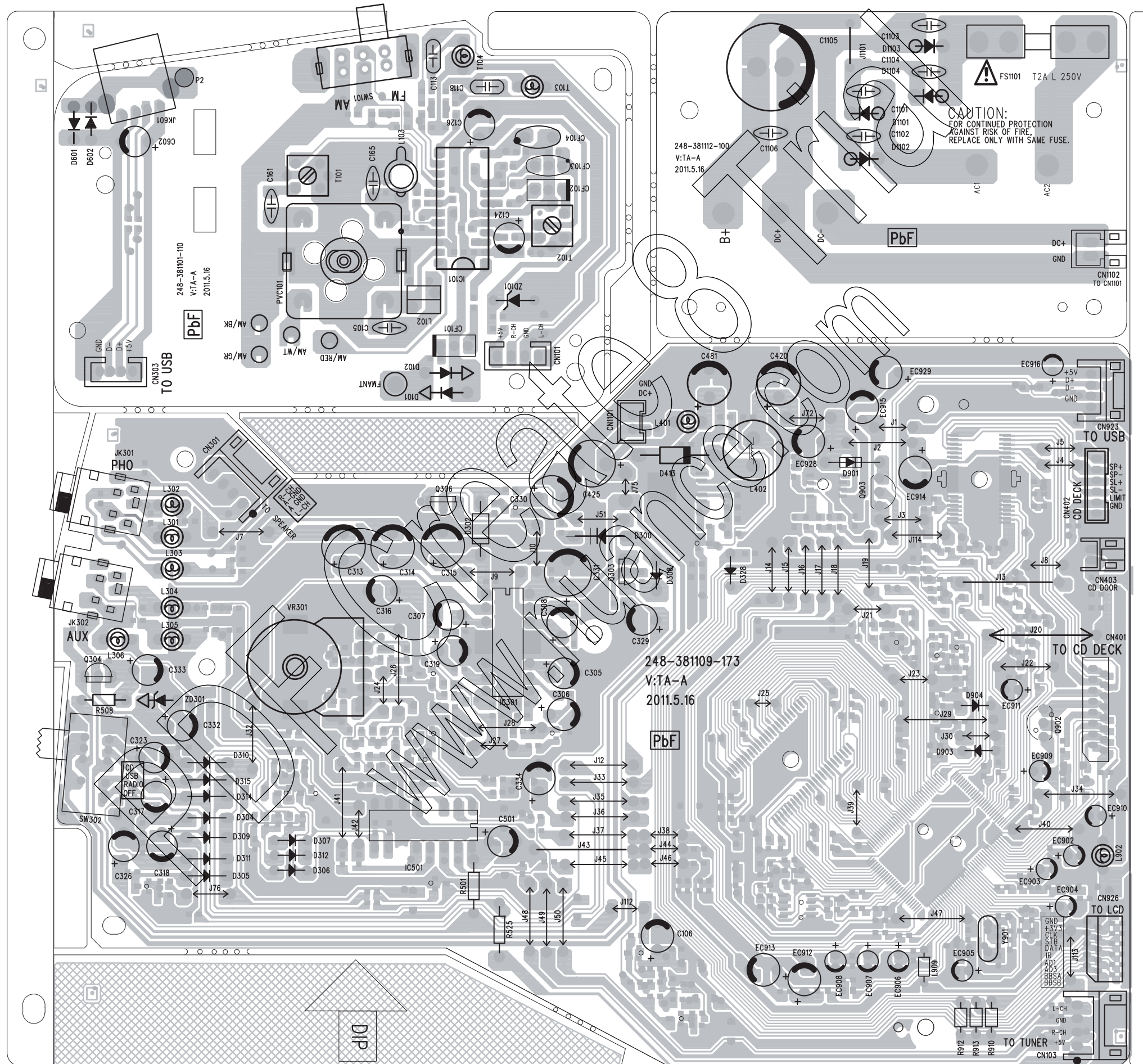

LAYOUT DIAGARM - MAIN/RADIO/RECTIFIER BOARD
BOTTOM SIDE VIEW

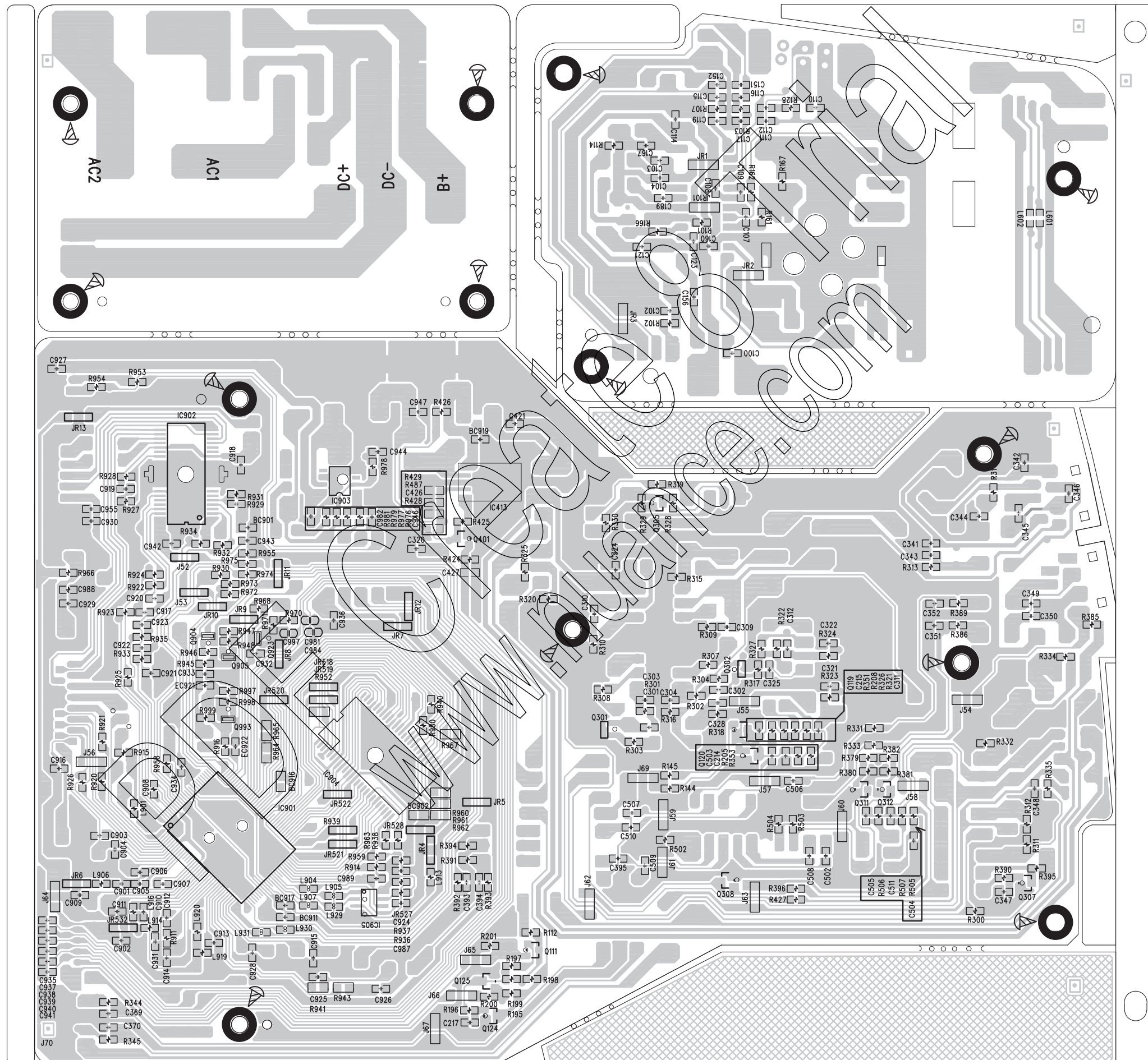

CIRCUIT DIAGRAM - DISPLAY BOARD

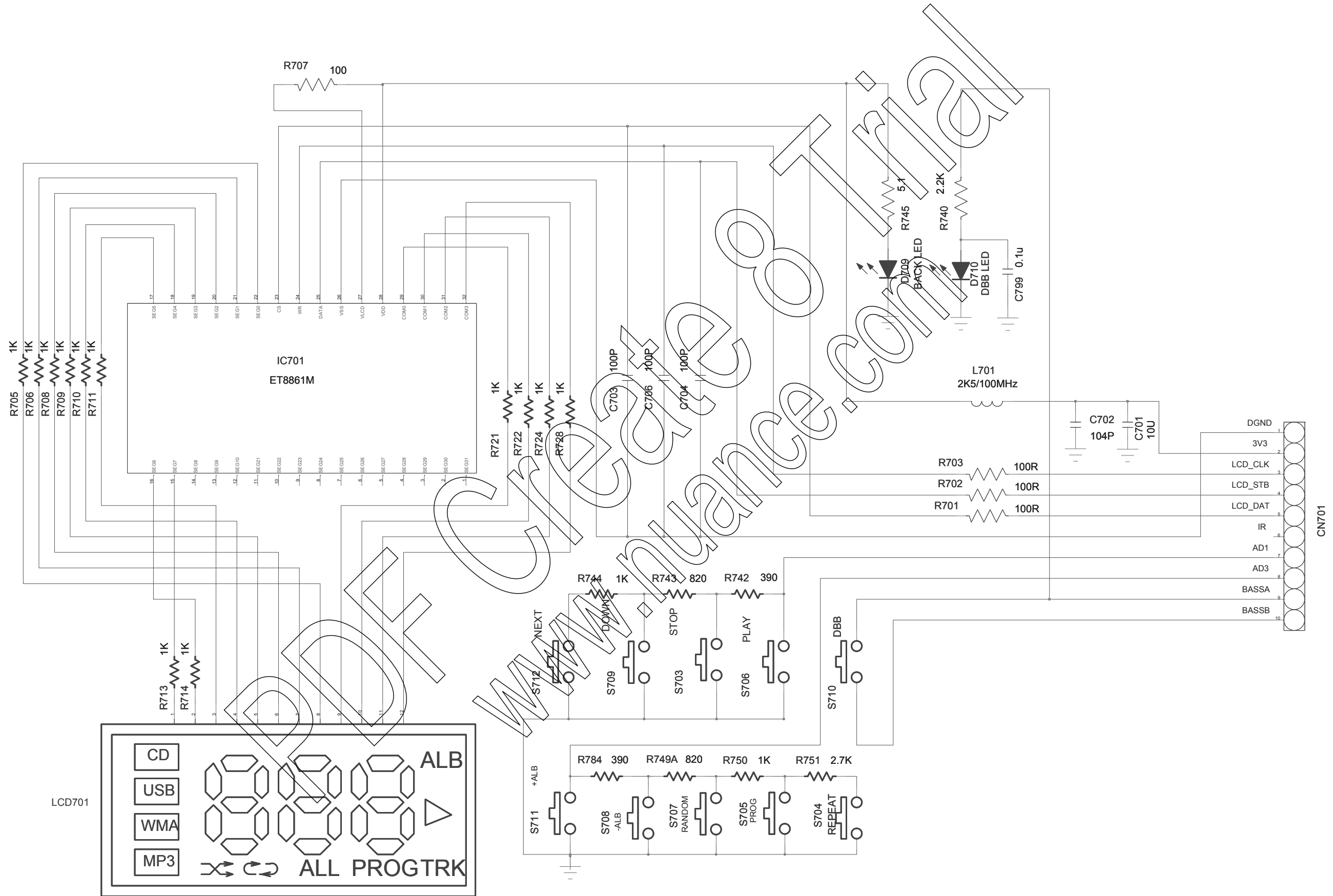

LAYOUT DIAGRAM - DISPLAY BOARD

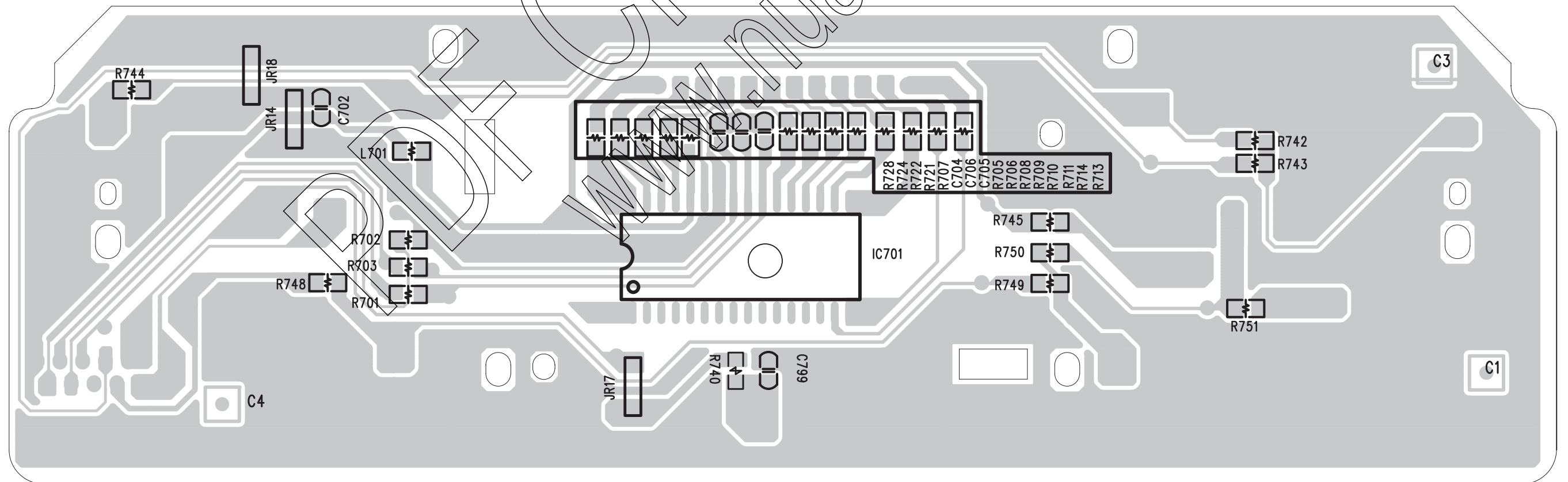
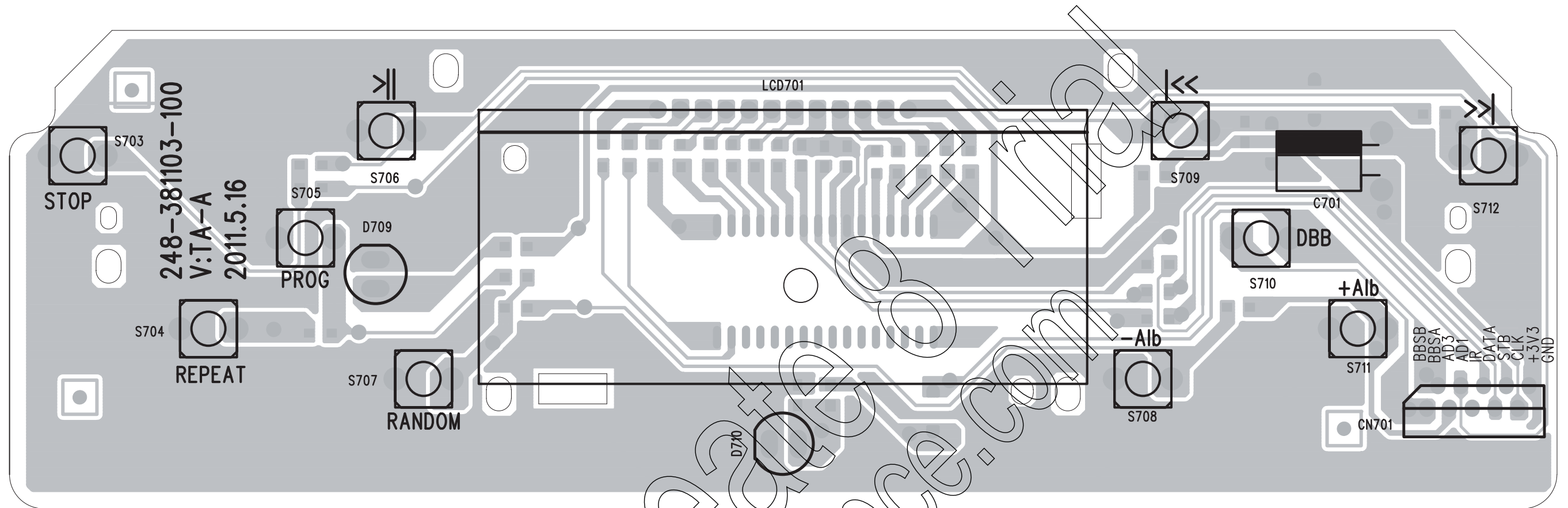

EXPLODED VIEW DIAGRAM

