

**DUAL LOW NOISE OPERATIONAL AMPLIFIERS****AZ4580****General Description**

The AZ4580 is a dual low noise operational amplifier. It is specifically designed for audio systems to improve tone control; it can also be used in pre-amplifier, industrial measurement tools and applications where gain and phase matched channels are mandatory.

The IC features monolithic silicon chip, internal frequency compensation, low noise, low distortion, high gain and high bandwidth. The AZ4580 can operate under dual power supply voltage up to $\pm 18V$ or single power supply up to 36V.

Features

- Operating voltage: $\pm 2V \sim \pm 18V$
- Large DC voltage gain: 110dB typ.
- Low input noise voltage: $0.7 \mu V_{RMS}$ typ.
- Wide gain bandwidth product: 15 MHz typ.
- Low distortion: 0.0005% typ.
- Slew rate: $7V/\mu s$ typ.
- Package outline: DIP8, SOIC8

Applications

- Audio AC-3 decoded system
- Audio amplifier

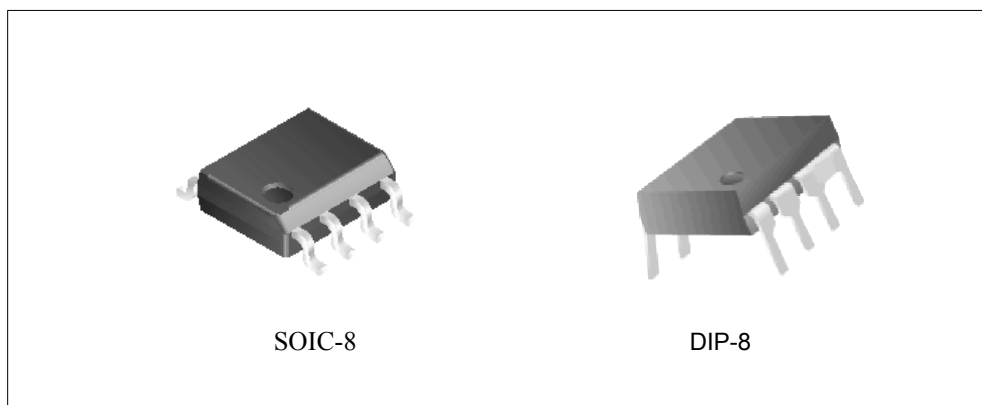
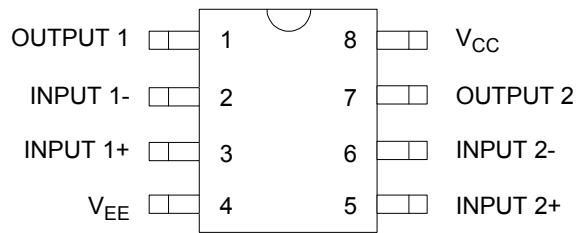

Figure 1. Package Types of AZ4580



Pin Configuration



Top View

Figure 2. Pin configuration of AZ4580

Functional Block Diagram

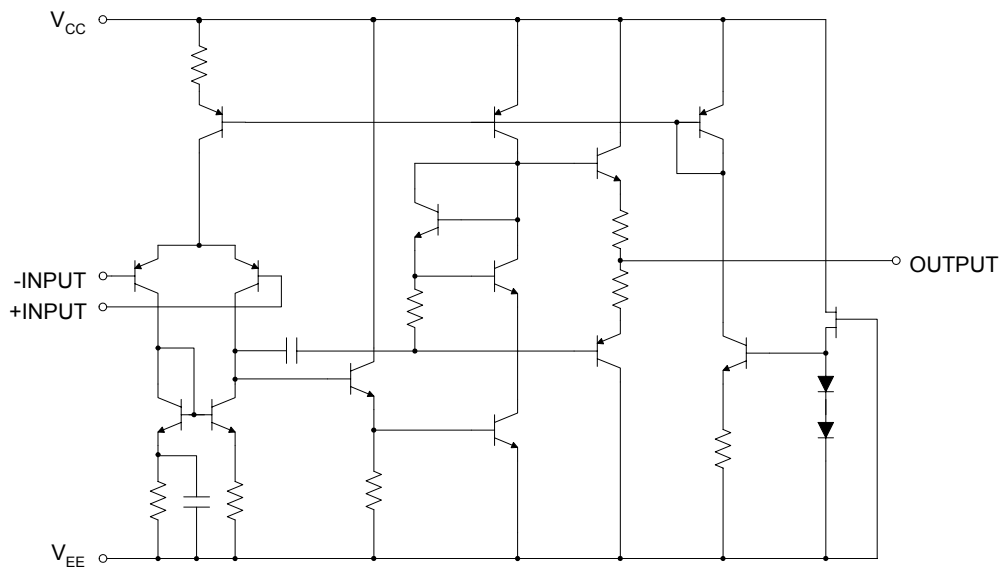

Figure 3. Representative Schematic Diagram of AZ4580

**DUAL LOW NOISE OPERATIONAL AMPLIFIERS****AZ4580****Ordering Information**

Package	Temperature Range	Part Number	Packing Type
SOIC-8	-40°C to 85°C	4580M	Tube, Reel
DIP-8		AZ4580P	Tube

Absolute Maximum Ratings (Note 1)

Parameter	Min.	Max.	Unit
Power Supply Voltage	V_{CC}	+ 20	V
	V_{EE}	- 20	
Differential Input Voltage	V_{ID}	± 30	V
Input Voltage	V_{IC}	± 15	V
Power Dissipation		DIP-8 800	mW
		SOIC-8 800	
Operating Temperature Range	T_{OP}	-40 to 85	°C
Storage Range	T_{STG}	-60 to 150	°C
ESD (Human Body Mode)		4000	V
ESD (Machine Mode)		350	

Note 1: Stresses greater than those listed under "Absolute Maximum Ratings" may cause permanent damage to the device. These are stress ratings only, and functional operation of the device at these or any other conditions beyond those indicated under "Recommended Operation Ratings" is not implied. Exposure to "Absolute Maximum Ratings" for extended periods may affect device reliability.

Recommended Operation Conditions

Parameter	Min.	Max.	Unit
Supply Voltage	± 2	± 18	V

**DUAL LOW NOISE OPERATIONAL AMPLIFIERS****AZ4580****Electrical Characteristics**Operating Conditions: $V_{CC} = +15V$, $V_{EE} = -15V$, $T_A = 25^\circ C$ unless otherwise specified.

Parameter	Conditions	Min.	Typ.	Max.	Unit
Supply Current	no load	-	4	7	mA
Input Offset Voltage	$R_S \leq 10K\Omega$	-	0.5	3	mV
Input Offset Current		-	5	100	nA
Input Bias Current		-	150	500	nA
Input Common Mode Voltage Range		± 12	± 13.5	-	V
Common Mode Rejection Ratio	$V_{CM} = 0V$ to $V_{CC} - 1.5V$, $R_S \leq 10K\Omega$	80	110	-	dB
Large Signal Voltage Gain	$R_L = 2K\Omega$, $V_O = \pm 10V$	90	110	-	dB
Power Supply Rejection Ratio	$R_S \leq 10K\Omega$	80	110	-	dB
Slew Rate	$R_L \geq 2K\Omega$	-	7	-	V / μS
Gain Bandwidth Product	$R_L = 2K\Omega$, $f = 10KHz$	-	15	-	MHz
Total Harmonic Distortion	$A_V = 20dB$, $V_O = 5V$ $R_L = 2K\Omega$, $f = 1KHz$	-	0.0005	-	%
Equivalent Input Noise Voltage	RIAA $R_S = 2.2K\Omega$, 30KHz LPF	-	0.7		μV_{RMS}



Typical Characteristics

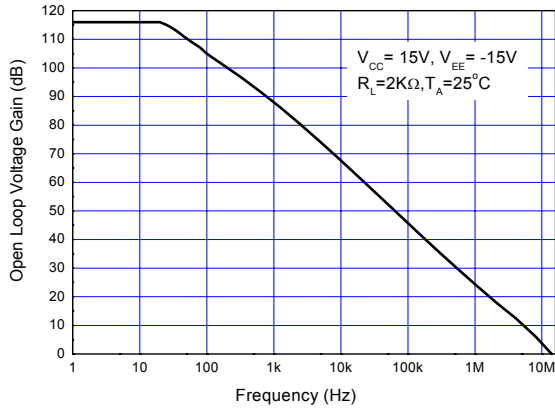

Figure 4. Open Loop Voltage Gain vs. Frequency

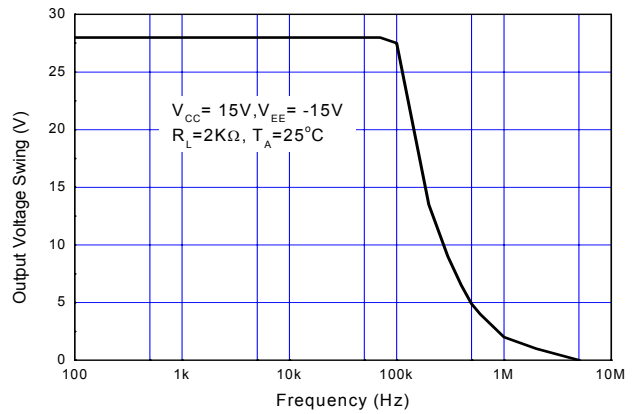

Figure 5. Maximum Output Voltage Swing vs. Frequency

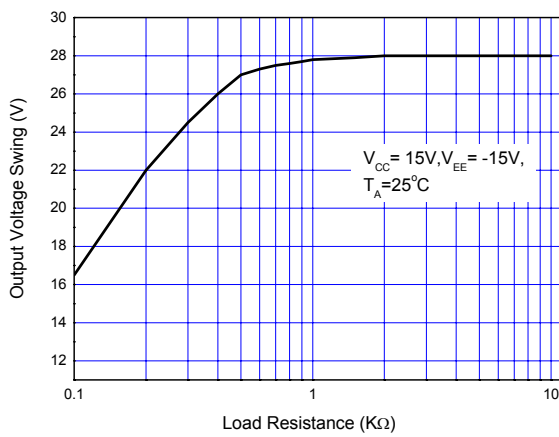

Figure 6. Maximum Output Voltage Swing vs. Load Resistance

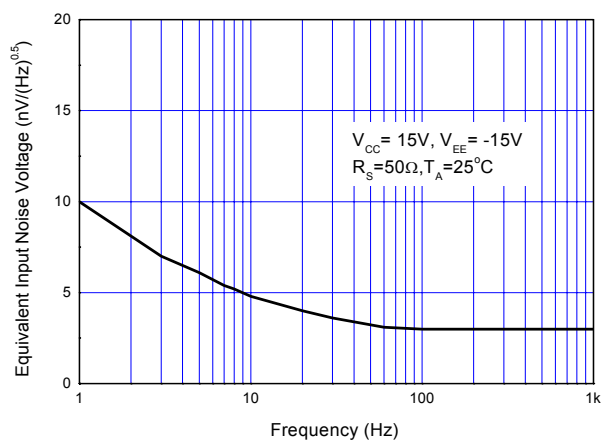

Figure 7. Equivalent Input Noise Voltage vs. Frequency



Typical Characteristics (Continued)

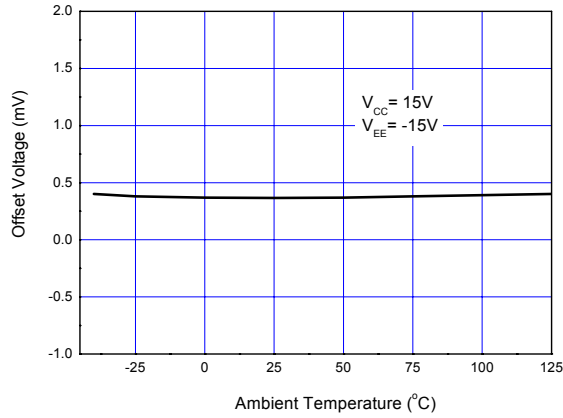

Figure 8. Input Offset Voltage vs. Temperature

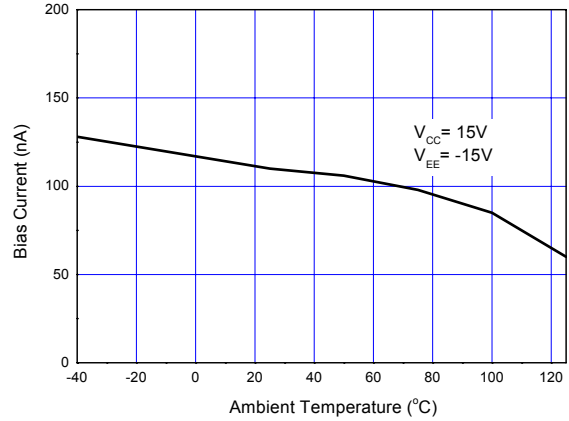

Figure 9. Input Bias Current vs. Temperature

Typical Applications

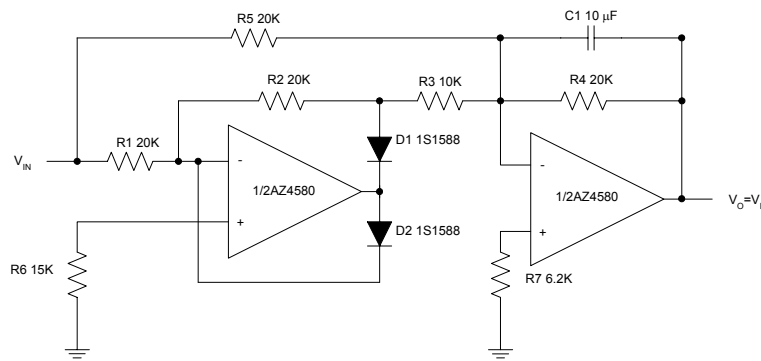

Figure 10. AC/DC Converter



Typical Applications (Continued)

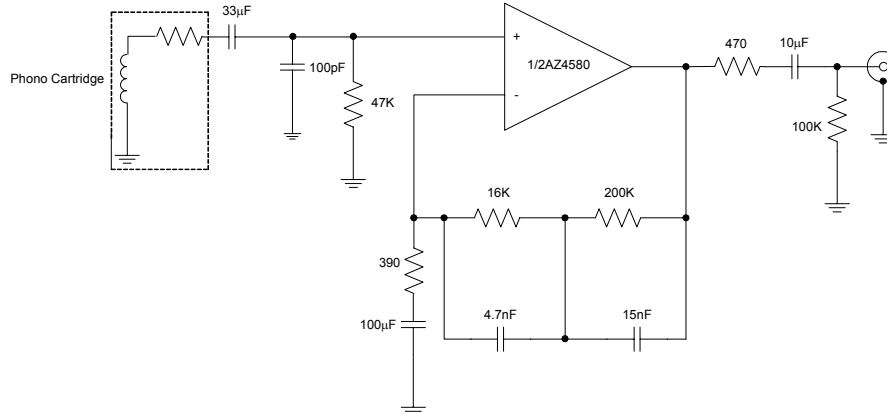

Figure11. RIAA Preamp

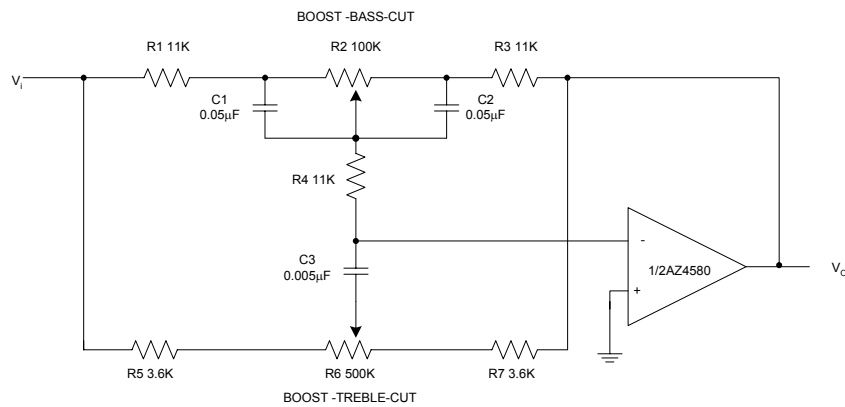

Figure12. Tone Control



DUAL LOW NOISE OPERATIONAL AMPLIFIERS

AZ4580

Mechanical Dimensions

DIP - 8

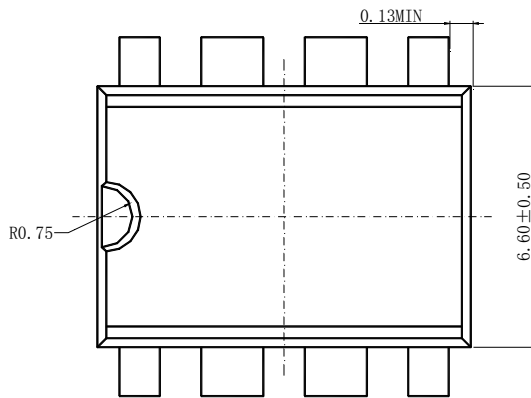
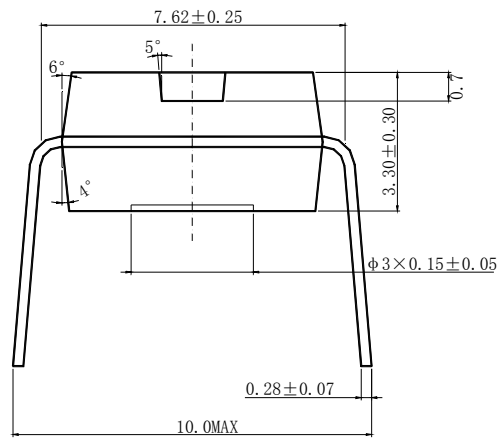
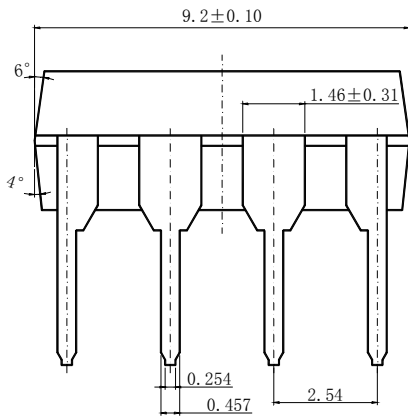



Mechanical Dimensions (Continued)

SOIC - 8

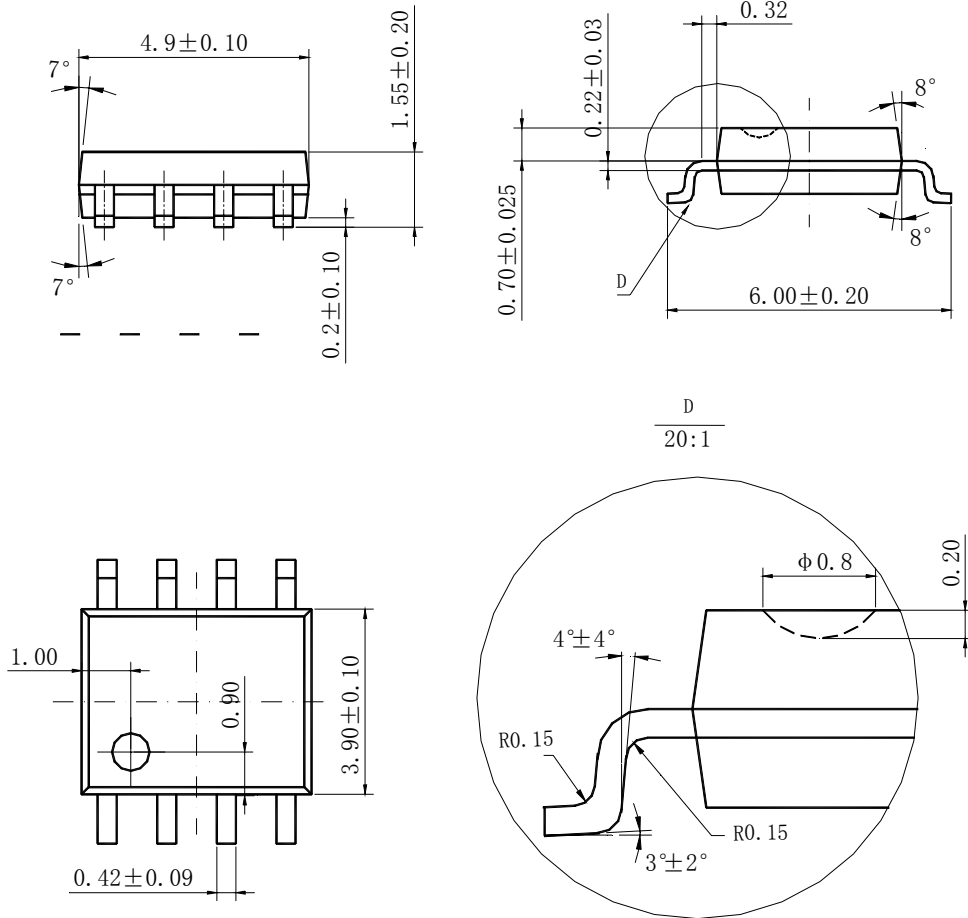



<http://www.aacmicro.com>

USA: 1510 Montague Expressway, San Jose, CA 95131, USA

Tel: 408-433-9888, Fax: 408-432-9888

China: 8th Floor, Zone B, 900 Yi Shan Road, Shanghai 200233, China

Tel: 86-21-6495-9539, Fax: 86-21-6485-9673

Taiwan: 8F, No.50, Lane10, Kee Hu Road, Nei Hu, TaiPei 114, Taiwan

Tel: 886-2-2657-8811, Fax: 886-2-2657-9090

IMPORTANT NOTICE

Advanced Analog Circuits Corporation reserves the right to make changes to its products or specifications at any time, without notice, to improve design or performance and to supply the best possible product. Advanced Analog Circuits does not assume any responsibility for use of any circuitry described other than the circuitry embodied in Advanced Analog Circuits' products. The company makes no representation that circuitry described herein is free from patent infringement or other rights of Advanced Analog Circuits Corporation.