

AZ8512

MICROMINIATURE POLARIZED RELAY

FEATURES

- Microminiature size: Height: .212 inches (5.4 mm); Length: .551 inches (14.0 mm); Width: .354 inches (9.0 mm)
- Low power consumption
- Meets FCC Part 68.302 1500 V lightning surge
- Surface mount type with "L" shaped terminals
- Single side stable and latching available
- UL, CUR file E43203

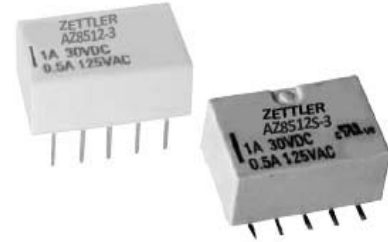

CONTACTS

Arrangement	DPDT (2 Form C)
Ratings	Resistive load: Max. switched power: 30 W or 62.5 VA Max. switched current: 2A Max. switched voltage: 110 VDC or 125 VAC
Rated Load UL	2 A at 30 VDC resistive (100K cycles, 40°C) 1 A at 30 VDC resistive (200K cycles, 70°C) 0.5 A at 125 VAC resistive (100K cycles, 70°C)
Material	AgNi + Au plated
Resistance	< 100 milliohms initially

COIL (Polarized)

Power At Pickup Voltage (typical)	79mW Single Side Stable 56mW 1 Coil Latching 113mW 2 Coils Latching
Temperature	Max. 105°C (221°F)

NOTES

1. All values at 20°C (68°F).
2. Relay has fixed coil polarity.
3. Relay may pull in with less than "Must Operate" value.
4. Relay adjustment may be affected if undue pressure is exerted on relay case.
5. For complete isolation between the relay's magnetic fields, it is recommended that a .197" (5.0 mm) space be provided between adjacent relays.
6. Specifications subject to change without notice.

GENERAL DATA

Life Expectancy Mechanical Electrical	Minimum operations 1 x 10 ⁸ 2 x 10 ⁵ at 1A, 30 VDC resistive 1 x 10 ⁵ at 0.5A, 125VAC resistive
Operate Time (typical)	3 ms at nominal coil voltage
Release Time (typical)	3 ms at nominal coil voltage (with no coil suppression)
Dropout	Greater than 10% of nominal coil voltage
Dielectric Strength (at sea level)	1000 Vrms between contact sets 750 Vrms across contacts 1000 Vrms contact to coil Meets FCC part 68.302 1500 V lightning surge
Insulation Resistance	1000 megohms min. at 25°C, 500 VDC, 50% RH
Humidity	5% to 85% RH
Ambient Temperature Operating	At nominal coil voltage -40°C (-40°F) to 70°C (185°F)
Vibration Functional Destructive	.118" DA 10 to 55 Hz .197" DA 10 to 55Hz
Shock Functional Destructive	50 G 100 G
Enclosure	Plastic sealed
Terminals	copper alloy, DIP, SMT
Weight	1.5 grams

AZ8512

RELAY ORDERING DATA

COIL SPECIFICATIONS - SINGLE SIDE STABLE				ORDER NUMBER*
Nominal Coil VDC	Must Operate VDC	Max Continuous VDC	Coil Resistance $\pm 10\%$	
1.5	1.13	2.25	16	AZ8512-1.5
2.4	1.8	3.6	41.3	AZ8512-2.4
3	2.25	4.5	64.3	AZ8512-3
4.5	3.38	6.7	145	AZ8512-4.5
5	3.75	7.5	178	AZ8512-5
6	4.5	9.0	257	AZ8512-6
9	6.75	13.5	579	AZ8512-9
12	9.0	18.0	1028	AZ8512-12
24	18.0	36.0	2880	AZ8512-24

*Add suffix "S" after AZ8512 for surface mount. Add suffix "TR" for tape & reel package (600 relays per reel)

COIL SPECIFICATIONS - 1 COIL LATCHING				ORDER NUMBER*
Nominal Coil VDC	Must Operate VDC	Max Continuous VDC	Coil Resistance $\pm 10\%$	
1.5	1.13	2.25	22.5	AZ8512P1-1.5
2.4	1.8	3.6	58	AZ8512P1-2.4
3	2.25	4.5	90	AZ8512P1-3
4.5	3.38	6.7	203	AZ8512P1-4.5
5	3.75	7.5	250	AZ8512P1-5
6	4.5	9.0	360	AZ8512P1-6
9	6.75	13.5	810	AZ8512P1-9
12	9.0	18.0	1440	AZ8512P1-12
24	18.0	36.0	3840	AZ8512P1-24

*Add suffix "S" after AZ8512P1 for surface mount. Add suffix "TR" for tape & reel package (600 relays per reel)

COIL SPECIFICATIONS - 2 COIL LATCHING				ORDER NUMBER*
Nominal Coil VDC	Must Operate VDC	Max Continuous VDC	Coil Resistance $\pm 10\%$	
1.5	1.13	2.25	11.3	AZ8512P2-1.5
2.4	1.8	3.6	29	AZ8512P2-2.4
3	2.25	4.5	45	AZ8512P2-3
4.5	3.38	6.7	101	AZ8512P2-4.5
5	3.75	7.5	125	AZ8512P2-5
6	4.5	9.0	180	AZ8512P2-6
9	6.75	13.5	405	AZ8512P2-9
12	9.0	18.0	720	AZ8512P2-12
24	18.0	36.0	1920	AZ8512P2-24

*Add suffix "S" after AZ8512P2 for surface mount. Add suffix "TR" for tape & reel package (600 relays per reel)

AMERICAN ZETTLER, INC.

www.azettler.com

AZ8512

MECHANICAL DATA

Outline Dimensions

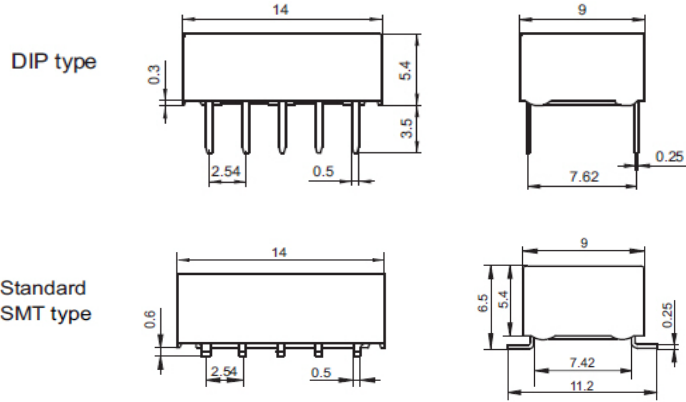

PCB Layout
(Bottom view)

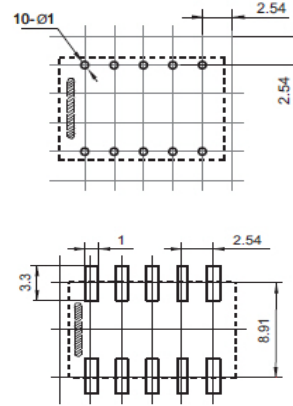

Wiring Diagram

Single side stable

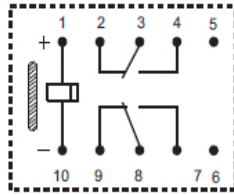

Deenergized condition

1 coil latching

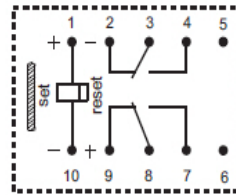

Reset condition

2 coils latching

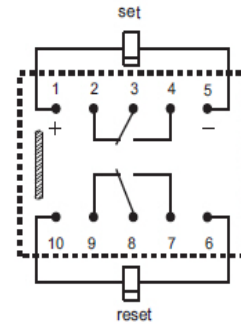

Reset condition

AZ8512

Reel Dimensions

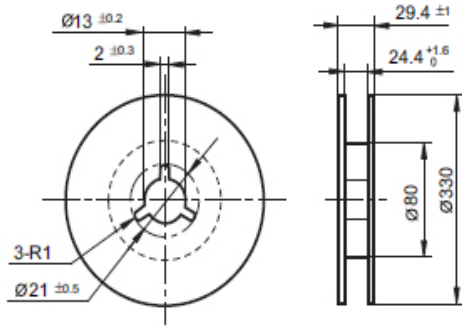

Direction of Relay Insertion

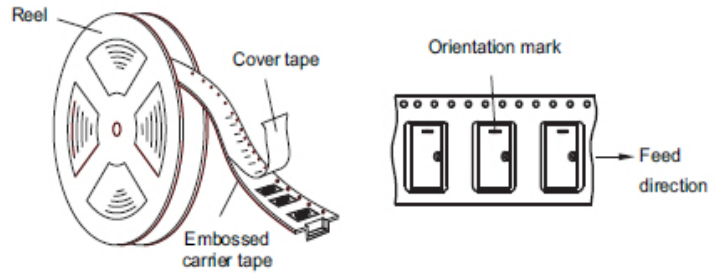

- Notes: 1) Packing: 600pcs/reel, 4 reels/carton.
2) MOQ for reel packing is 600pcs.

Tape Dimensions

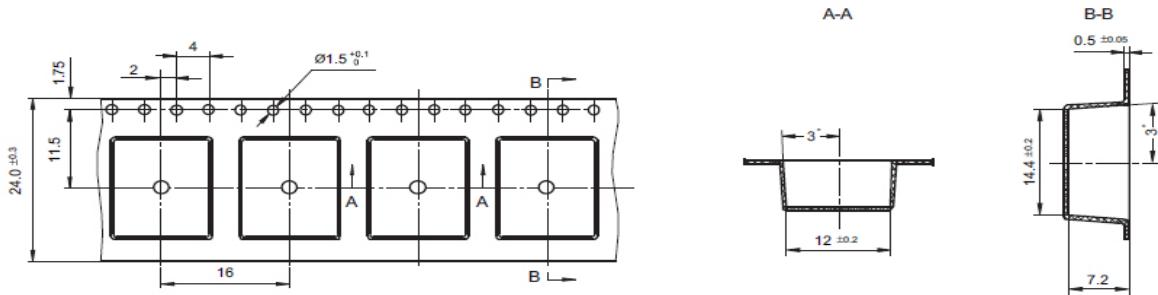

Characteristic Curves

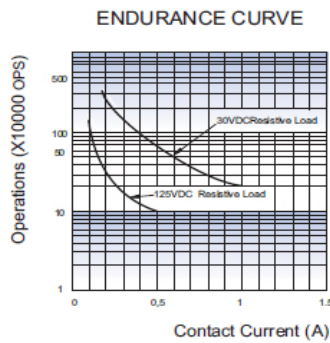
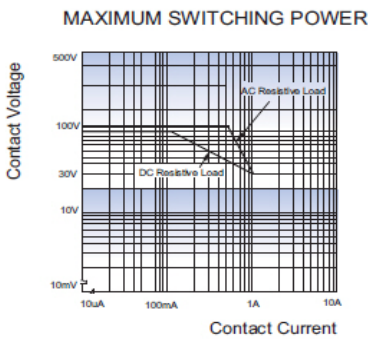

Recommended Temperature/Time Reflow Soldering Profile

