

Features

- Ultra low capacitance: 0.4pF typical (I/O to I/O)
- Ultra low leakage: nA level
- Low operating voltage: 3.3V
- Low clamping voltage with snap back technology
- Up to 4 lines protects
- Leadless flow -through package
- Complies with following standards:
 - IEC 61000-4-2 (ESD) immunity test
Air discharge: $\pm 30\text{kV}$
Contact discharge: $\pm 30\text{kV}$
 - IEC61000-4-4 (EFT) 40A (5/50ns)
 - IEC61000-4-5 (Lightning) 5A (8/20 μs)
- RoHS Compliant

Applications

- HDMI 1.3 & 1.4, USB 2.0 & 3.0 and MDDI ports
- Monitors and flat panel displays
- Set -top box and Digital TV
- Video graphics cards
- Digital Video Interface (DVI)
- Notebook Computers
- PCI Express and Serial SATA Ports

Mechanical Characteristics

- Package: DFN2510P10
- Lead Finish: Matte Tin
- UL Flammability Classification Rating 94V-0
- Quantity Per Reel:3000pcs
- Reel Size:7inch
- Device Marking:3324

Absolute Maximum Ratings ($T_{amb}=25^{\circ}\text{C}$ unless otherwise specified)

Parameter	Symbol	Value	Unit
Peak Pulse Power (8/20 μs)	P _{pp}	60	W
ESD per IEC 61000-4-2 (Air)	V _{ESD}	± 30	Kv
ESD per IEC 61000-4-2 (Contact)		± 30	
Operating Temperature Range	T _J	-55 to +125	$^{\circ}\text{C}$
Storage Temperature Range	T _{STJ}	-55 to +150	$^{\circ}\text{C}$

Dimensions DFN2510P10

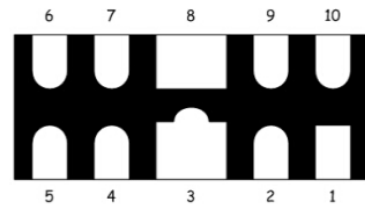

Pin Configuration

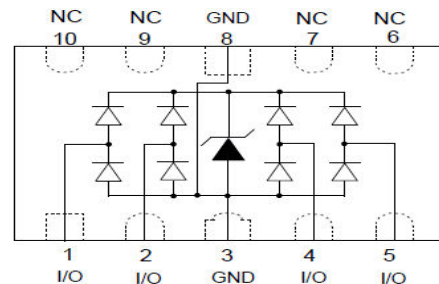

Electrical Characteristics(TA=25°C unless otherwise specified)

Parameter	Symbol	Min	Typ	Max	Unit	Test Condition
Reverse Working Voltage	VRWM			3.3	V	Any I/O pin to ground
Breakdown Voltage	VBR	4.5			V	It = 1mA, any I/O pin to ground
Reverse Leakage Current	IR			0.5	µA	VRWM = 3.3V, any I/O pin to ground
Clamping Voltage	VC			6.5	V	I _{PP} = 1A (8 x 20µs pulse), any I/O pin to ground
Clamping Voltage	VC			10	V	I _{PP} = 5A (8 x 20µs pulse), any I/O pin to ground
Junction Capacitance	CJ		0.4		pF	VR = 0V, f = 1MHz, between I/O pins
Junction Capacitance	CJ		0.6		pF	VR = 0V, f = 1MHz, any I/O pin to ground

Characteristic Curves

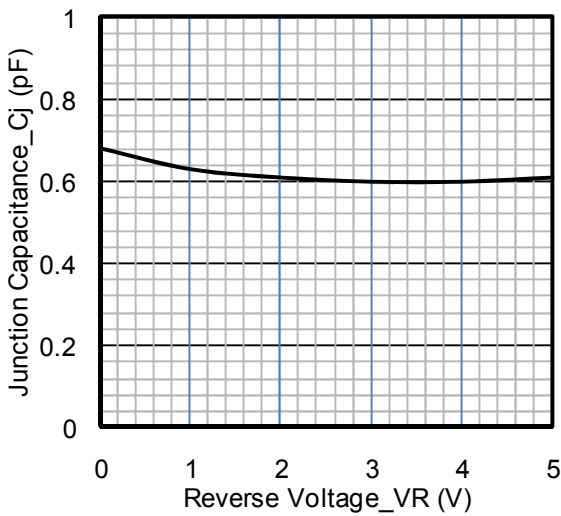

Junction Capacitance vs. Reverse Voltage

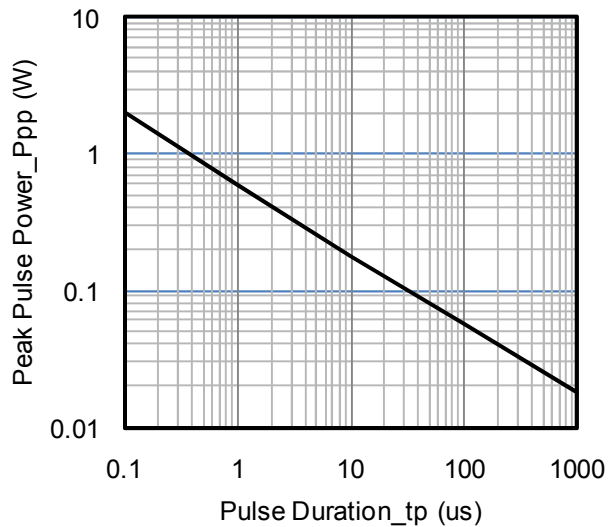

Peak Pulse Power vs. Pulse Time

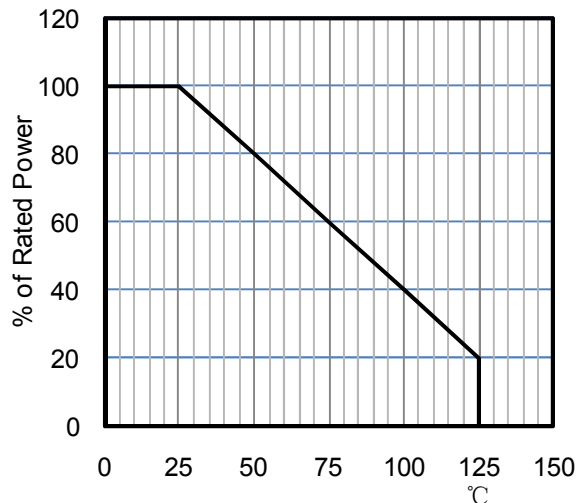
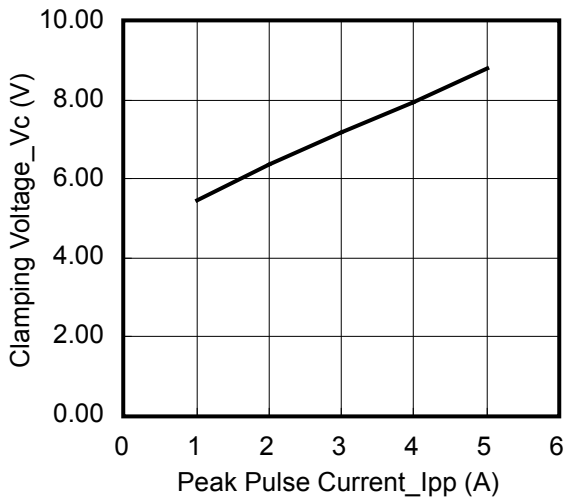

Clamping Voltage vs. Peak Pulse Current

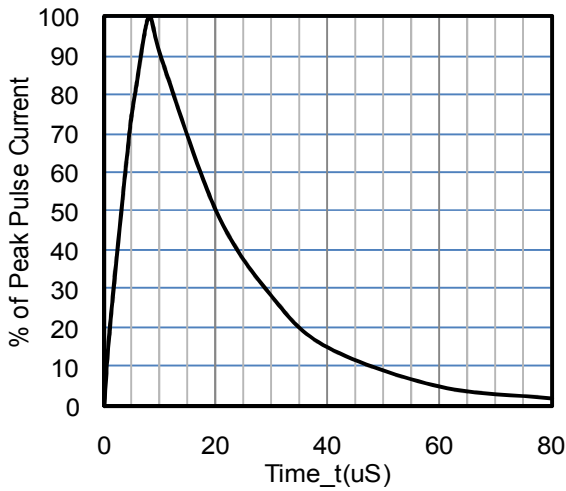

8 X 20uS Pulse Waveform

Power Derating Curve

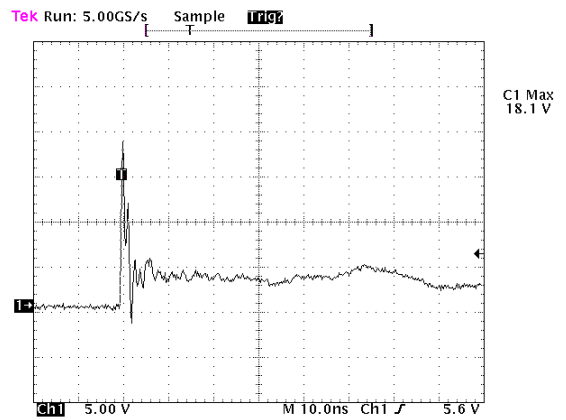

ESD Clamping Voltage

8 kV Contact per IEC61000-4-2

Typical Application

The AZ9143-04F is designed for easy PCB layout by allowing the traces to run straight through the device. The PCB traces could be used to connect the pin pairs for each line. For example, line 1 enters at pin 1 and exits at pin 10 and the PCB trace connects Pin 1 and Pin 10 together. Ground is connected at Pin 3 and Pin 8.

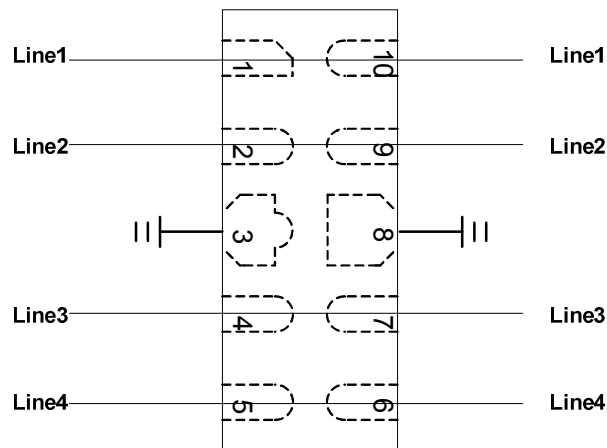

AZ9143-04F on USB 3.0 Port Application

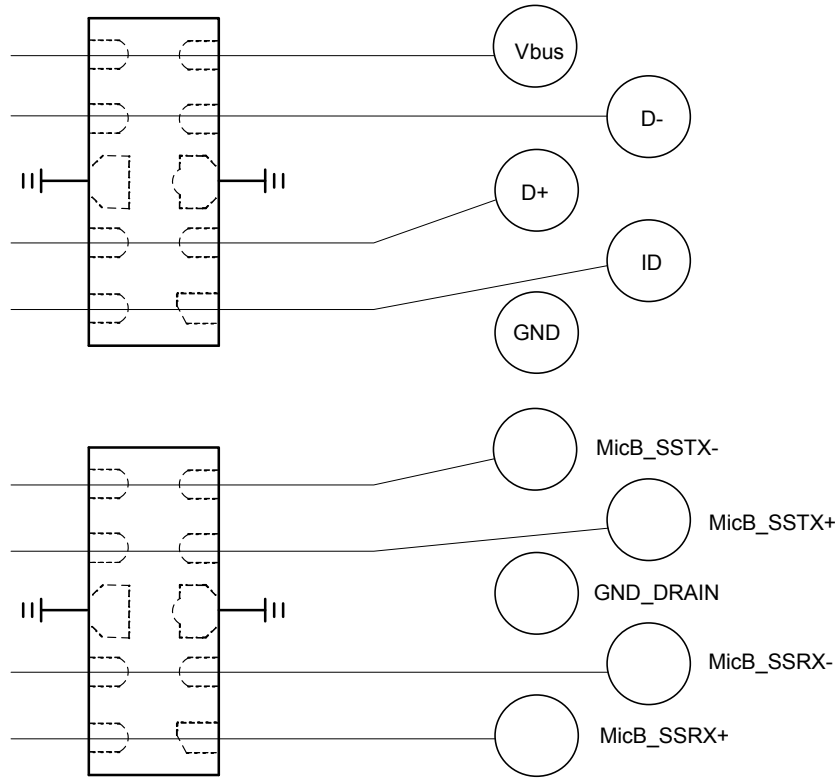

AZ9143-04F on DVI Port Application

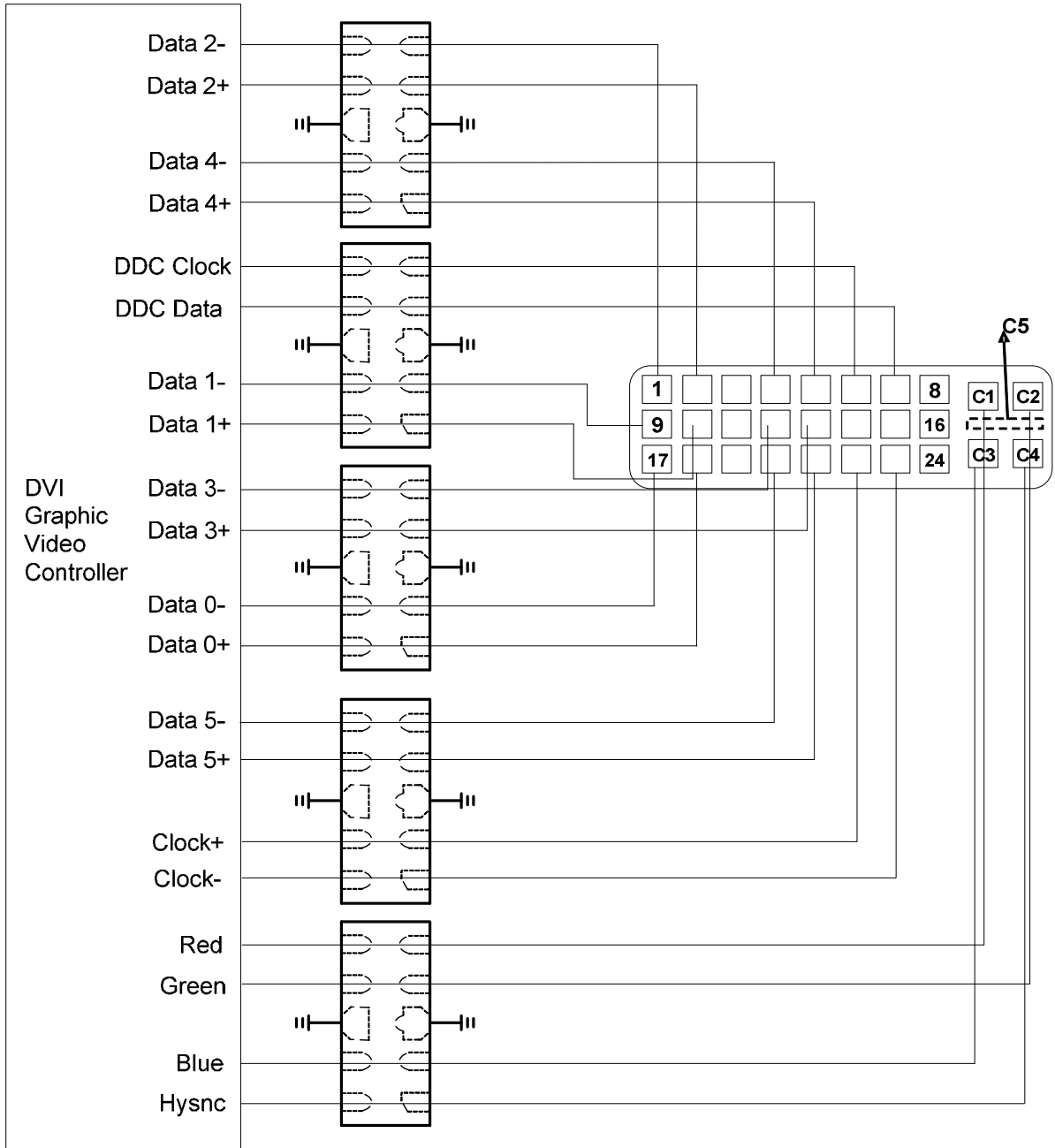

AZ9143-04F on HDMI Port Application

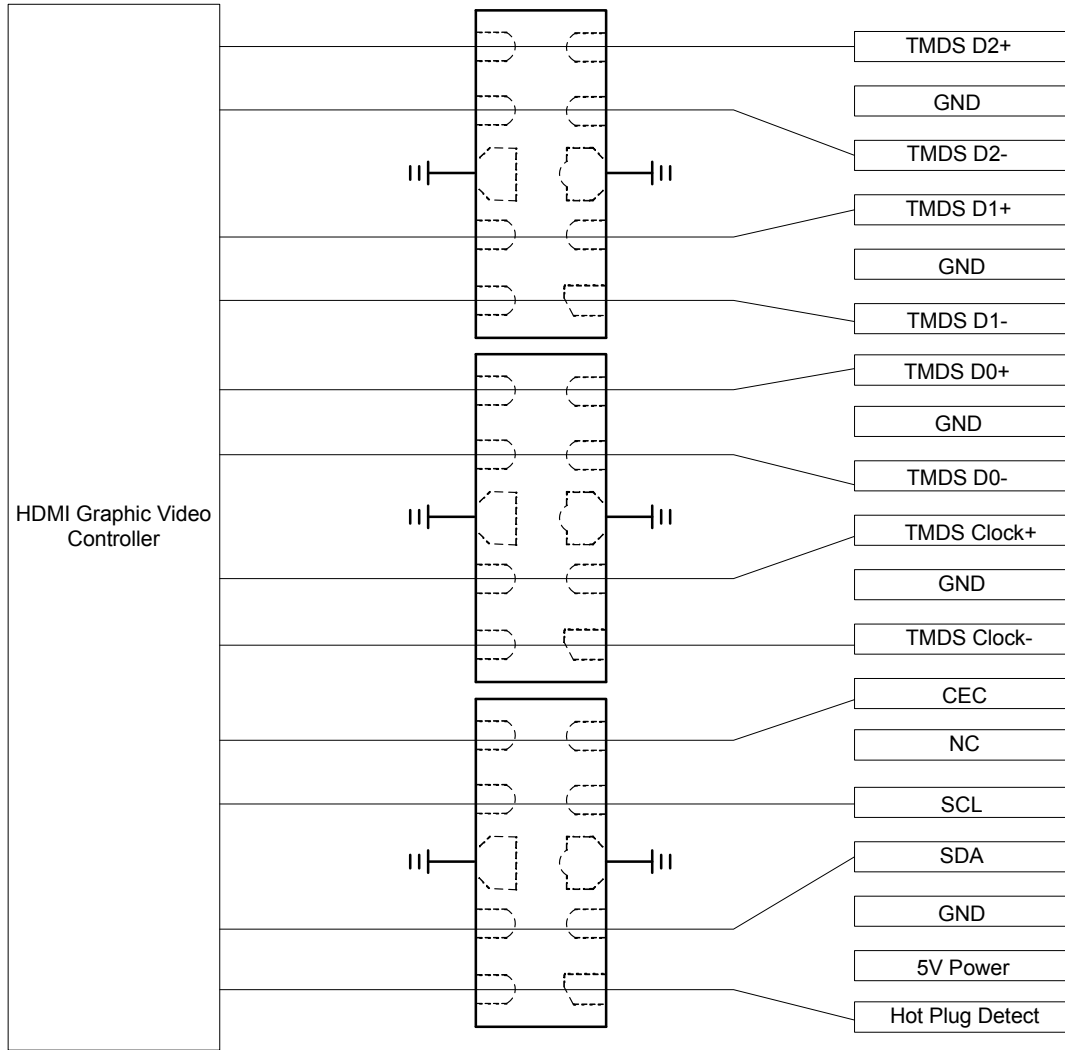

AZ9143-04F on MDDI Port Application

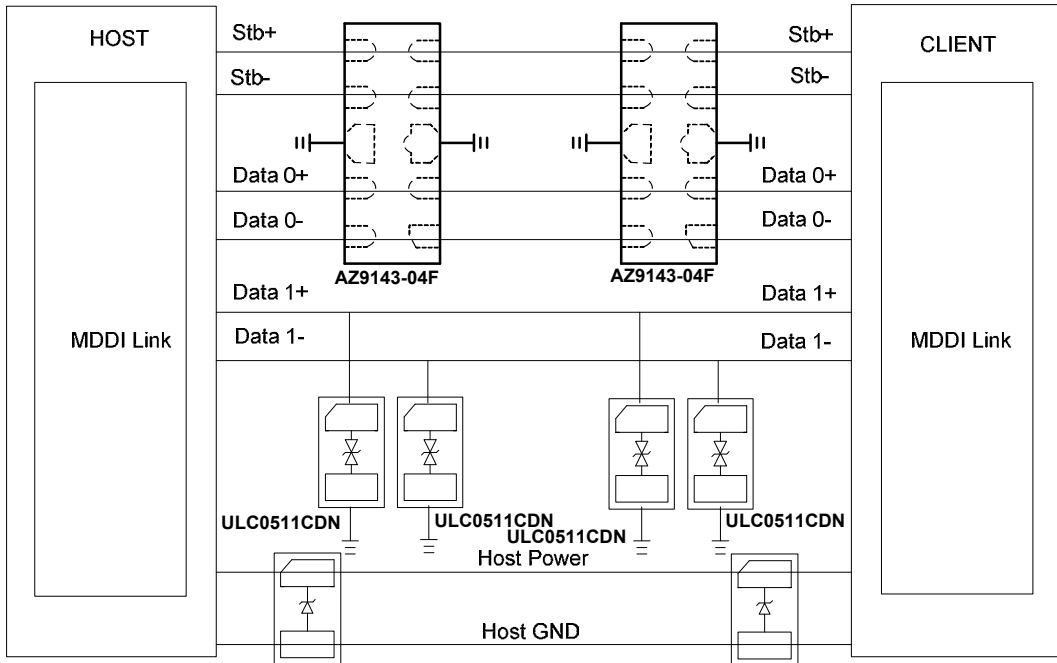

AZ9143-04F on 10/100 Base Ethernet Port Application

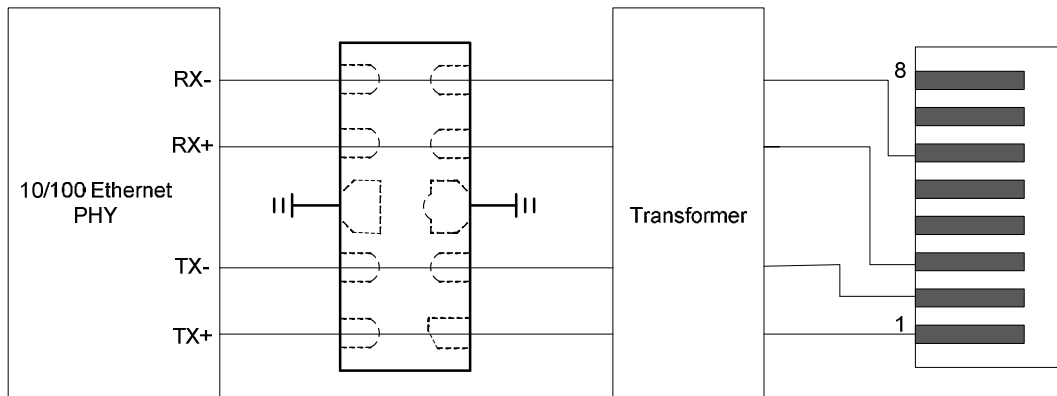

AZ9143-04F on VGA Port Application

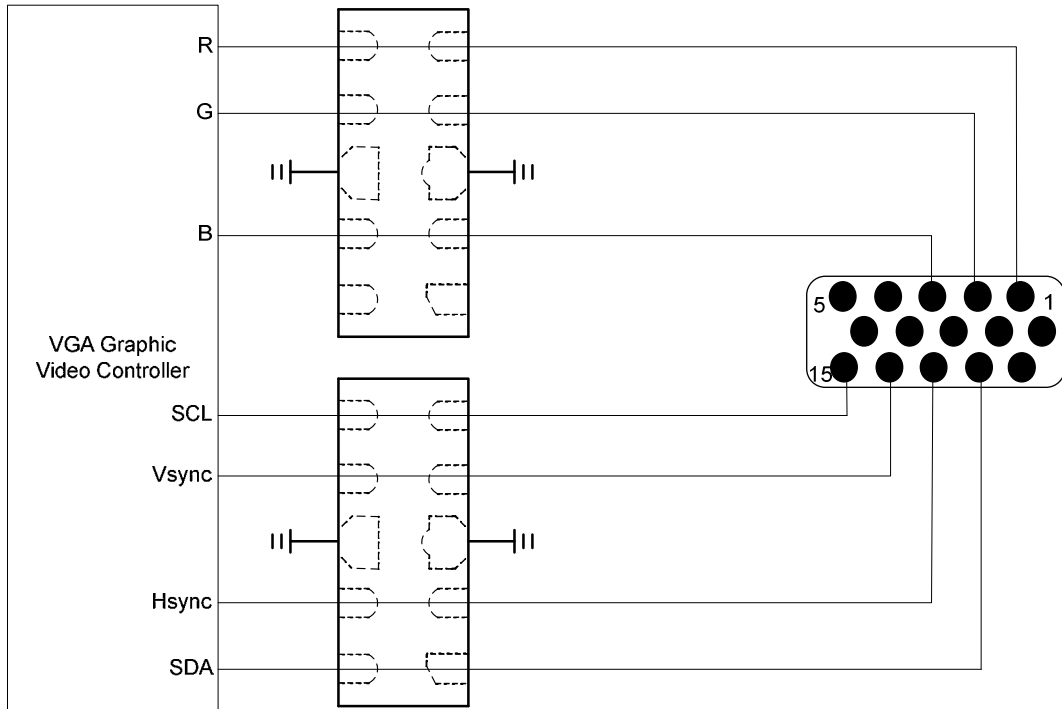

AZ9143-04F on eSATA Port Application

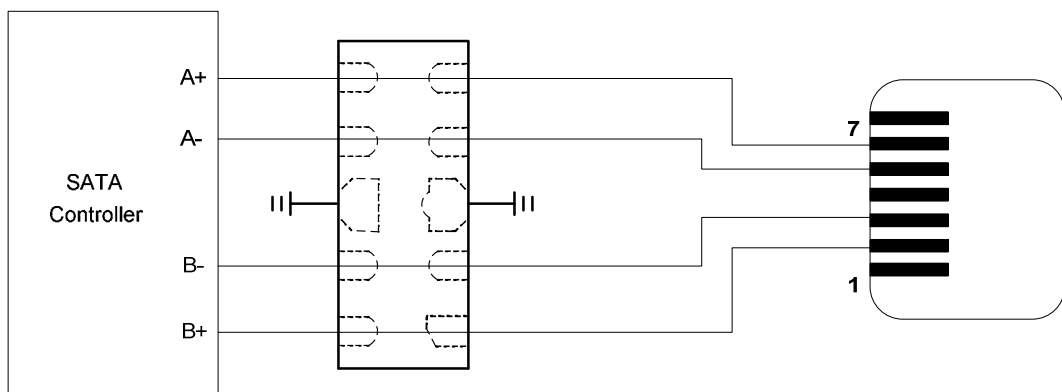

DFN2510P10 PACKAGE OUTLINE & DIMENSIONS

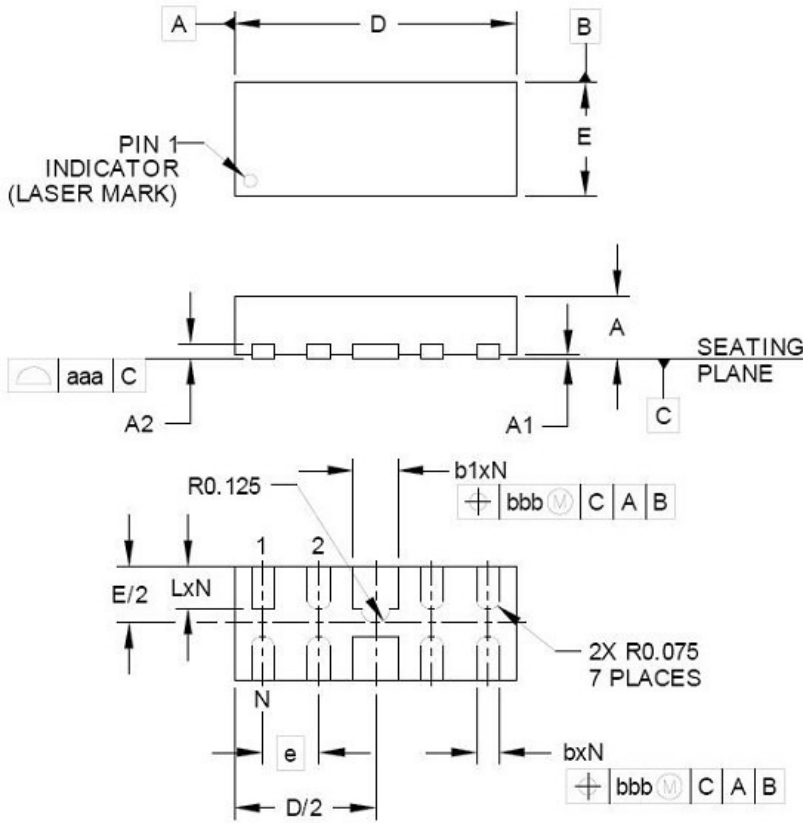

DIM	INCHES		MILLIMETERS			
	MIN	NOM	MAX	MIN	NOM	MAX
A	.020	.023	.026	0.50	0.58	0.65
A1	0.00	.001	.002	0.00	0.03	0.05
A2		(.005)			(0.13)	
b	.006	.008	.010	0.15	0.20	0.25
b1	.014	.016	.018	0.35	0.40	0.45
D	.094	.098	.102	2.40	2.50	2.60
E	.035	.039	.043	0.90	1.00	1.10
e		.020 BSC		0.50 BSC		
L	.012	.015	.017	0.30	0.38	0.425
N	10			10		
aaa	.003			0.08		
bbb	.004			0.10		

*** SOLDERING FOOTPRINT**

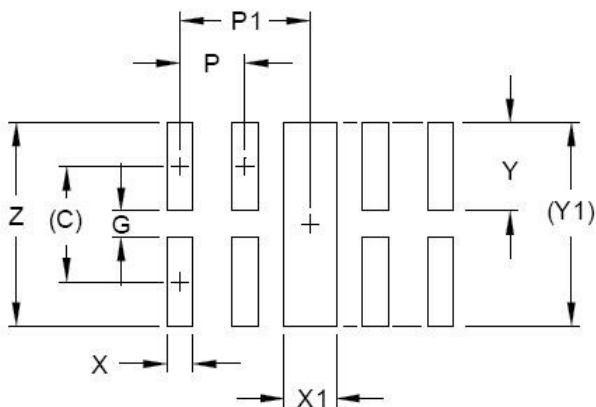

DIM	DIMENSIONS	
	INCHES	MILLIMETERS
C	(.034)	(0.875)
G	.008	0.20
P	.020	0.50
P1	.039	1.00
X	.008	0.20
X1	.016	0.40
Y	.027	0.675
Y1	(.061)	(1.55)
Z	.061	1.55