

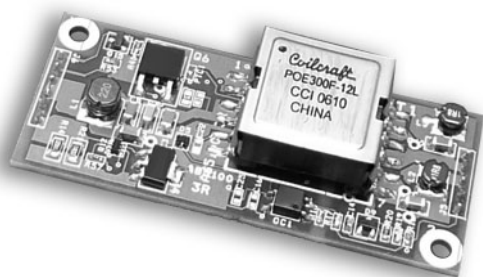

# Ag5100

## Power-Over-Ethernet Plus Module



## 1 Features

- IEEE802.3at compliant
- Maximum 30 Watt Output Power
- High efficiency DC/DC converter
- Wide adjustable output voltage range
- 1500Vdc isolation (input to output)
- Input voltage range 36V to 57V
- Low output ripple and noise
- Minimal (low cost) external components required
- Overload, thermal and short-circuit protection
- Operates with non-compliant POE+ PSE's
- Silver Telecom "design-in" assistance

## 2 Description

The Ag5100 is a High Power over Ethernet (PoE+) module that can deliver up to 30 Watts of output power. Suitable for applications such as IP Telephones, WiMAX access points, PTZ cameras and thin client terminals.

The Ag5100 has been designed to extract power from Power Sourcing Equipment (PSE) over a conventional twisted pair Category 5 Ethernet cable. The modules input conform to the IEEE803.2at standard for signature recognition and class programming.

The high efficiency DC/DC converter operates over a wide input voltage range and provides a regulated low ripple and low noise output. The DC/DC converter also has built-in overload, thermal and short-circuit output protection.

## Table of Contents

1	Features .....	1
2	Description.....	1
3	Ag5100 Product Selector.....	3
4	Pin Description .....	4
5	Functional Description .....	5
5.1	Inputs.....	5
5.2	PD Signature .....	5
5.3	Isolation .....	5
5.4	Power Classification .....	6
5.5	AT Detection.....	6
5.6	Input Selection.....	7
5.7	DC/DC Converter .....	7
5.8	Output Configuration .....	7
5.9	Output Adjustment.....	8
5.10	Output Power.....	9
5.11	Typical Connections .....	9
6	Typical Application.....	10
7	Typical Recommendations .....	11
8	Operating Temperature Range.....	12
9	Protection .....	13
10	Electrical Characteristics.....	14
10.1	Absolute Maximum Ratings <sup>1</sup> .....	14
10.2	Recommended Operating Conditions.....	14
10.3	DC Electrical Characteristics .....	14
11	Package .....	15
11.1	Ag5100.....	15

## Table of Figures

Figure 1: Block Diagram .....	3
Figure 2: Ag5100 DIL Package Format (Top View) .....	4
Figure 3: Typical System Diagram.....	5
Figure 4: 2 - Event Physical Layer Detect Configuration .....	6
Figure 5: Input Power Options .....	7
Figure 6: Output Configurations.....	8
Figure 7: Output Adjustment.....	8
Figure 8: Typical Connection Diagram.....	10
Figure 9: Typical Application.....	11
Figure 10: Typical Layout.....	12
Figure 11: Ag5100 Operating Profile .....	13

### 3 Ag5100 Product Selector

Part Number†	Nominal Output Voltage ‡	Maximum Output Power *
Ag5100	12V / 24V	24W Continuous / 30W Peak

\*At 25°C

† The Ag5100 fully meets the requirements of the RoHS directive 2002/95/EC on the restriction of hazardous substances in electronic equipment.

‡ Voltage depending on output configuration (Parallel or Series), see Section 5.7.

**Table 1: Ordering Information**

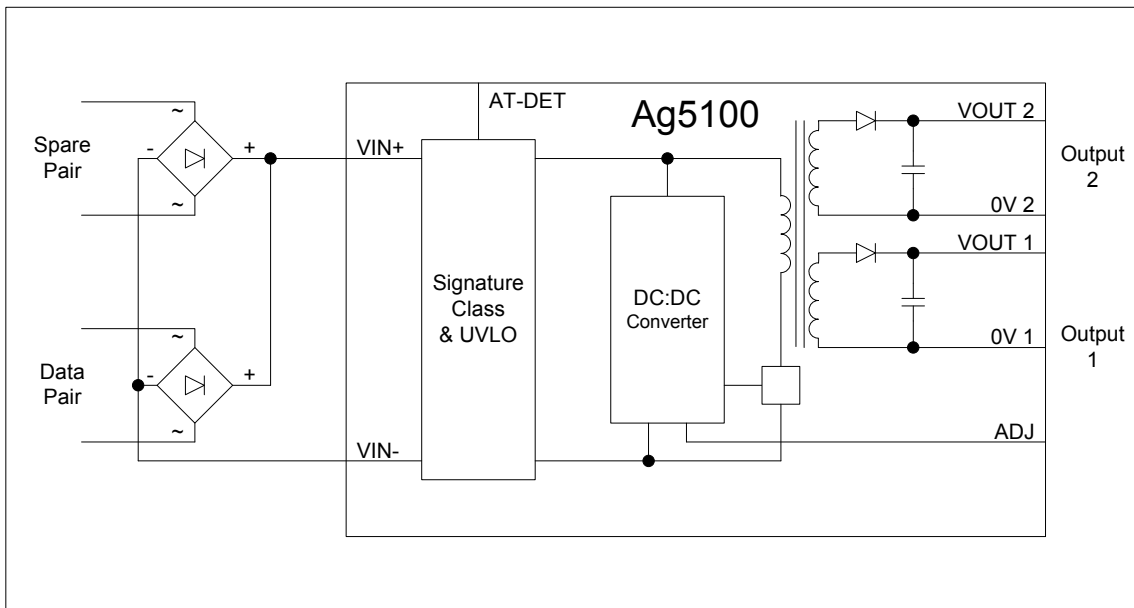

**Figure 1: Block Diagram**



**Figure 2: Ag5100 DIL Package Format (Top View)**

## 4 Pin Description

Pin #	Name	Description
1	VIN-	<b>Direct Input -.</b> This pin connects to the negative (-) output of the input bridge rectifiers.
2	AT-DET	<b>AT Detect Output.</b> This pin indicates if an IEEE802.3at PSE is supplying power to the Ag5100, see Section 5.4 for more details.
3	VIN+	<b>Direct Input +.</b> This pin connects to the positive (+) output of the input bridge rectifiers.
4		
5	IC	<b>Internal Connection.</b> Do not connect to this pin.
6	VIN-	<b>Direct Input -.</b> This pin is internally connected to pin 1.
7	ADJ	<b>Output Adjust.</b> The output voltage can be adjusted from its nominal value, by connecting an external resistor from this pin to either the VOUT 1 pin or the 0V 1 pin.
8	0V 1	<b>Ground.</b> The ground return for the VOUT 1 output.
9	VOUT 1	<b>DC Output.</b> This pin provides the main regulated output from the DC/DC converter.
10	0V 2	<b>Ground.</b> The ground return for the VOUT 2 output.
11	VOUT 2	<b>DC Output.</b> This pin provides the secondary output from the DC/DC converter.

## 5 Functional Description

### 5.1 Inputs

The Ag5100 has input pins VIN+ and VIN-, these must be connected to external bridge rectifiers to ensure the input is polarity protected, see Figure 3: Typical System Diagram.

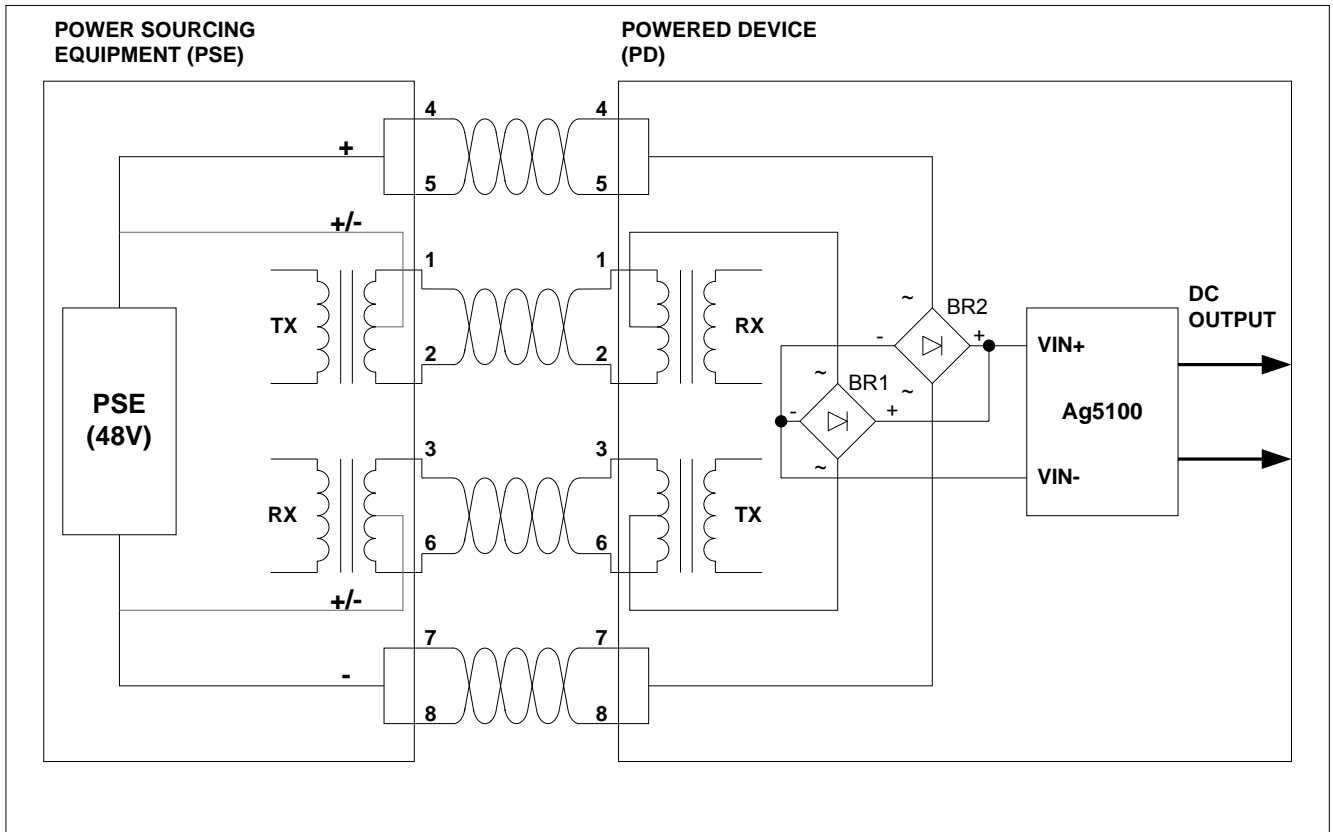

**Figure 3: Typical System Diagram**

### 5.2 PD Signature

The input Signature complies with both the IEEE802.3af and IEEE802.3at specifications. When the input is connected to a Power Sourcing Equipment (PSE) via a Cat 5 cable, it will automatically present a Powered Device (PD) signature to the PSE (when requested). The equipment will then recognise that a PD is connected to that line and supply power.

### 5.3 Isolation

To meet the safety isolation requirements of IEEE802.3at section 33.4.1 a PD must pass the electrical strength test of IEC 60950-1:2001 sub clause 6.2.1. This calls for either a) 1500Vac test or b) 2250Vdc test or c) 1500Vdc impulse test. The Ag5100 has been designed to meet c) 1500Vdc impulse test.

## 5.4 Power Classification

The Ag5100 classification is fixed at Class 4, this means that an IEEE802.3at Type 1 or an IEEE802.3af PSE will default to Class 0. However an IEEE802.3at Type 2 PSE will recognise Class 4 as a Type 2 PD.

## 5.5 AT Detection

The Ag5100 has an AT-DET output pin which is used to detect a 2 – Event Physical Layer classification as described in IEEE802.3at. If required the AT-DET pin can be connected directly to an opto-coupler as shown in Figure 4.

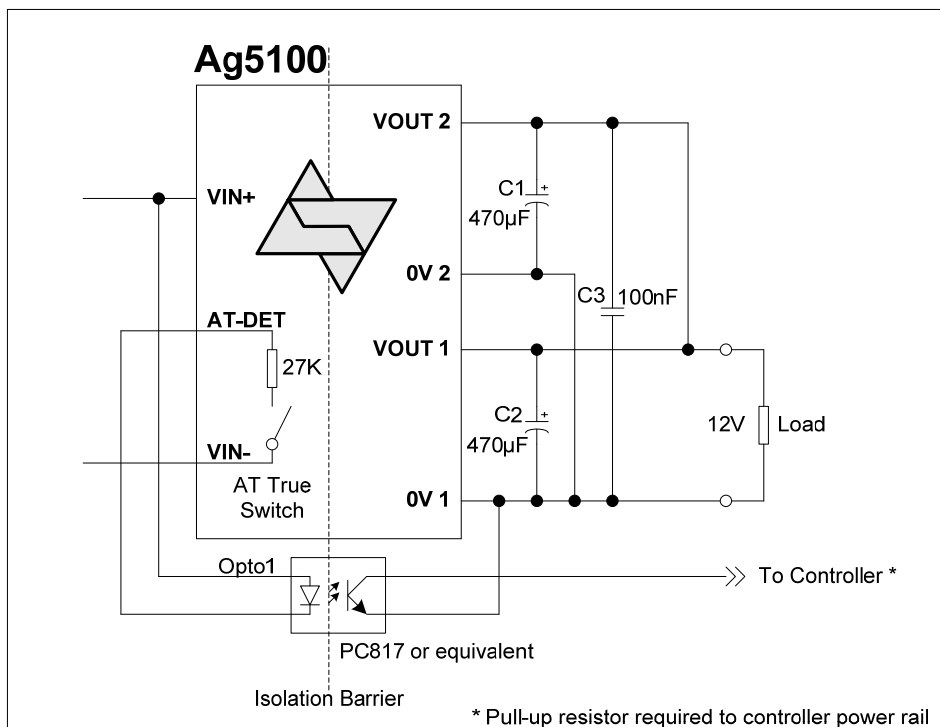

**Figure 4: 2 - Event Physical Layer Detect Configuration**

If the Ag5100 detects a 2 – Event Physical Layer classification the (AT True) switch will close and Opto1 will turn ON. Opto1 will be connected across the isolation barrier and the output collector can be connected to a controller (with a pull-up resistor connected to the controller's power rail). When Opto1 is ON the collector (output) will be Logic 0, the controller will then know that the PSE is capable of delivering over 15.4W. To complete the protocol the controller should then confirm that it is a Type 2 PD over the Data Link Layer.

If the Ag5100 detects a 1 – Event Physical Layer classification, Opto1 will be OFF and the output collector will be Logic 1 (via pull-up resistor). The controller can then assume that the PSE is limited to delivering up to 15.4W.

If the PSE does not support the Physical Layer classification, Opto1 will be OFF.

The Ag5100 will operate with non IEEE802.3at compliant POE+ PSE's.

## 5.6 Input Selection

By using two external bridge rectifiers as shown in Figure 3: Typical System Diagram, the Ag5100 can extract power from a PSE that applies power to the Spare Pair or to the Data Pair (see Figure 5: Input Power Options).

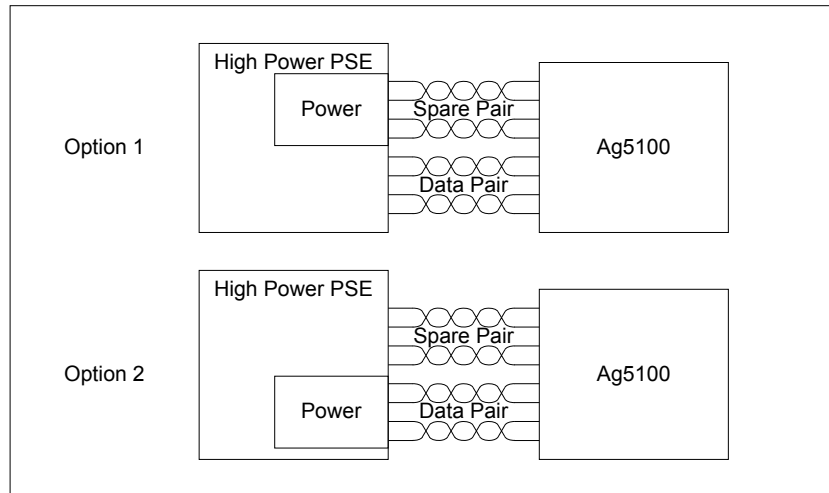

**Figure 5: Input Power Options**

## 5.7 DC/DC Converter

The Ag5100's DC/DC converter provides a regulated low ripple and low noise output that has built-in over-load and short-circuit output protection.

## 5.8 Output Configuration

The Ag5100 has two outputs which must be connected in parallel to provide 12V, or in series to provide 24V, as shown in Figure 6: Output Configurations.

The output 2 voltage (VOUT 2) tracks the output 1 voltage (VOUT 1). The use of the two outputs separately is not recommended due to voltage regulation issues.

It is important that C1 and C2 are both used and connected as close to the output pins of the Ag5100 as possible (for both configurations). It is also important that C3 (100nF) is connected between VOUT 2 to 0V 1 (close to the pins) to reduce the level of output ripple and noise.

**Note:** Too much capacitance can cause the PSE to shut-down as it may not be able to handle the in-rush current.

This has been known to happen when the Ag5100 is being used to power external equipment that already has built-in input capacitors. Under these conditions it may be necessary to reduce the value of C1 and C2 to 220 $\mu$ F or 100 $\mu$ F to compensate for the additional capacitance.

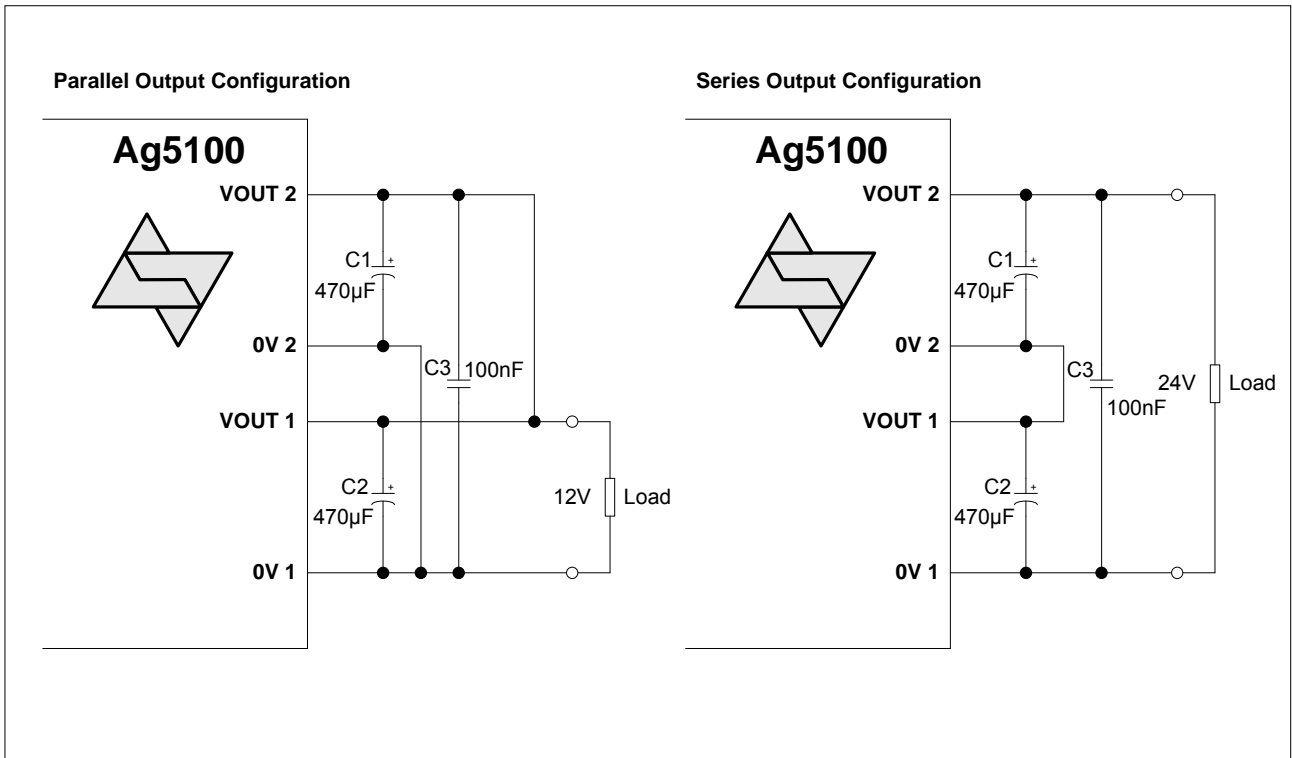
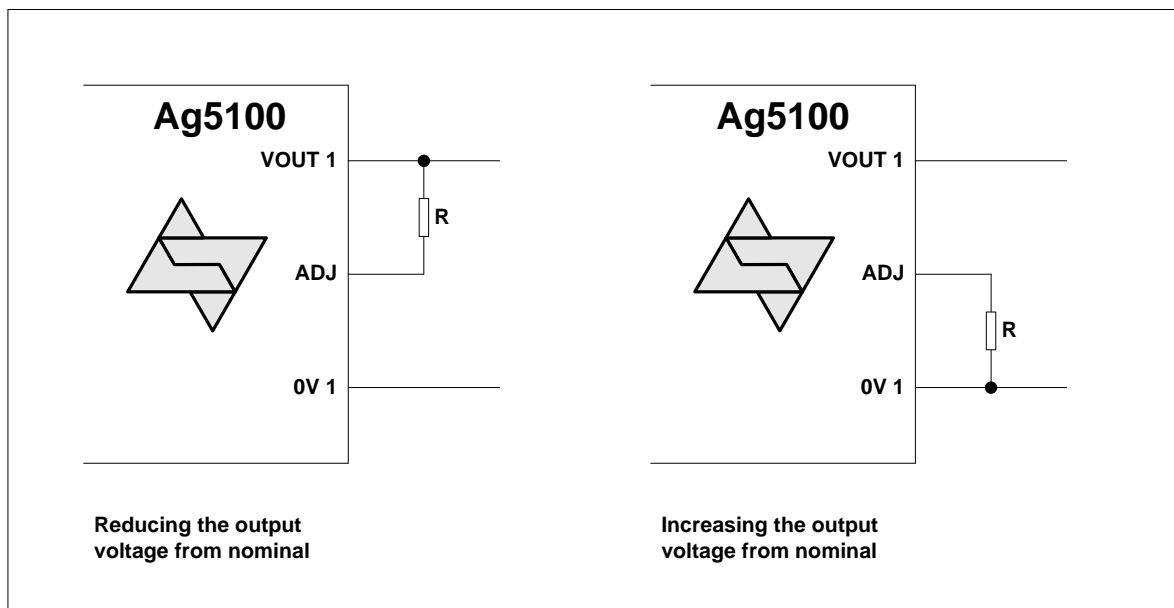

**Figure 6: Output Configurations**

### 5.9 Output Adjustment

The Ag5100 has an ADJ pin, which allows the output voltage to be increased or decreased from its nominal value.

Figure 7: Output Adjustment shows how the ADJ pin is connected: -



**Figure 7: Output Adjustment**



<b>Reducing the output voltage, connect R between ADJ and VOUT 1</b>		
Value of RA1	VOUT Parallel	VOUT Series
Open Circuit	12V	24V
100K	10.7V	21.4V
<b>Increasing the output voltage, connect R between ADJ and 0V 1</b>		
Value of RA2	VOUT Parallel	VOUT Series
Open Circuit	12V	24V
0 Ohms	13.35V	26.7V

**Table 2: Output Adjustment Resistor (R) Value**

The adjustment range allows the Ag5100 to provide an output voltage from 10.7V up to 26.7V, contact Silver Telecom for further details.

### 5.10 Output Power

The Ag5100 is capable of delivering a maximum output power of the Ag5100 is 24W continuous / 30W peak; however this is limited by the available input power to the module.

When calculating the output power, the following factors must be taken into account: -

1. Ag5100 efficiency
2. PSE output power (which could be limited by the IEEE802.3at specification)
3. Cable and connector losses
4. Input bridge rectifier losses

### 5.11 Typical Connections

Figure 8: Typical Connection Diagram. A minimum of 470µF must be connected across each output for output stability and positioned as close to the pins as possible. These capacitors are also needed for step load change performance and can be a standard low cost electrolytic; they do not need to be a low ESR type.

The Output Adjust input is optional and is provided to give great flexibility to the Ag5100. Further information on using this input can be found in section Output Adjustment.

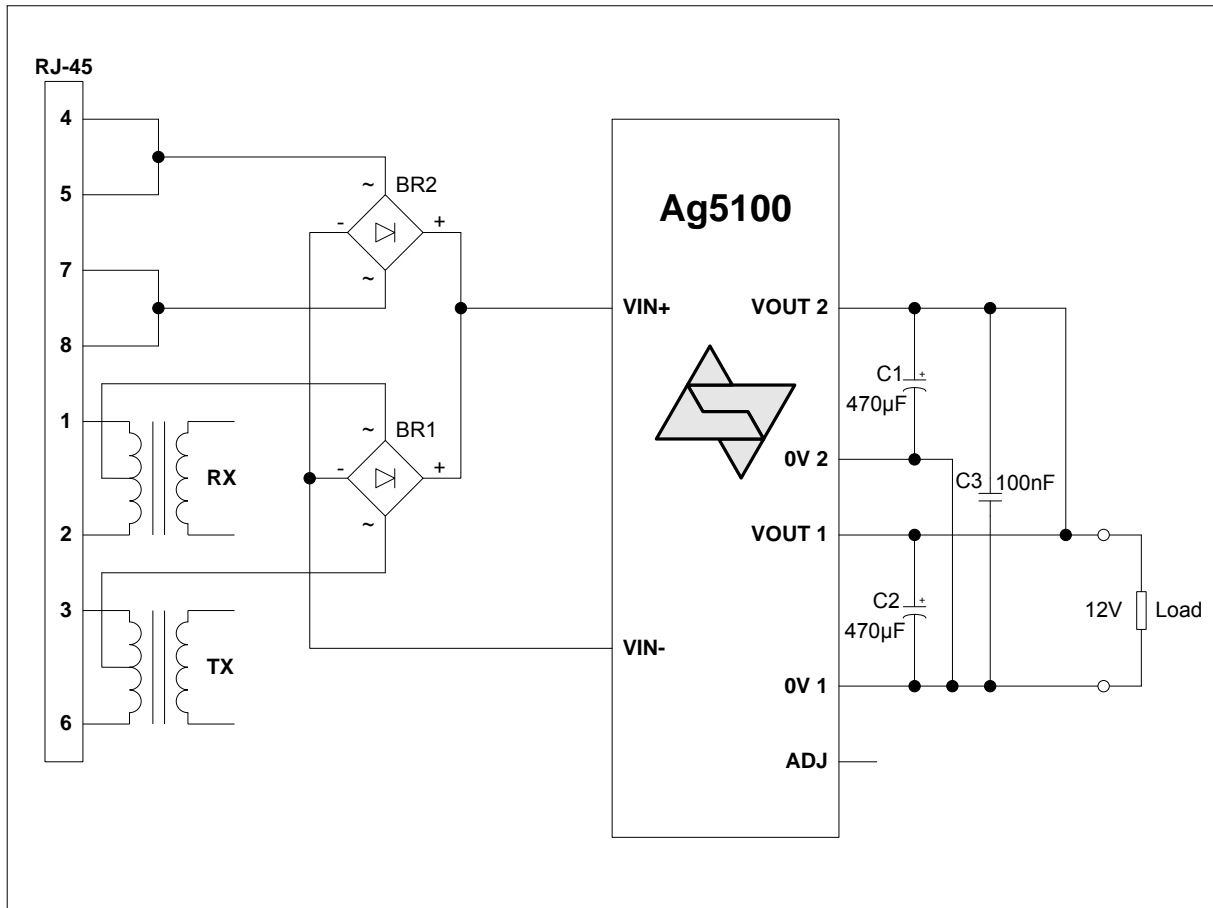

**Figure 8: Typical Connection Diagram**

## 6 Typical Application

The Ag5100 can be used in numerous applications, in the example shown in Figure 9: Typical Application, the data outputs from the Router are connected to the inputs of a Midspan. The Midspan will then add power (to the data from the Router) on each output that supports Power over Ethernet (PoE).

In this example port 1 is connected to an ethernet PTZ camera and port 2 is connected to a wireless access point, both of these devices have a built-in Ag5100. When the High Power Midspan is switched on (or when the device is connected), the Midspan will check each output for a PoE signature. On ports 1 and 2 the Ag5100 will identify themselves as PoE enabled devices and the Midspan will supply both data and power to these peripherals.

The other ports (shown in this example) will not have a PoE signature and the Midspan will only pass the data through to these peripherals. The Midspan will continuously monitor each output to see if a PoE enabled device has been added or removed.

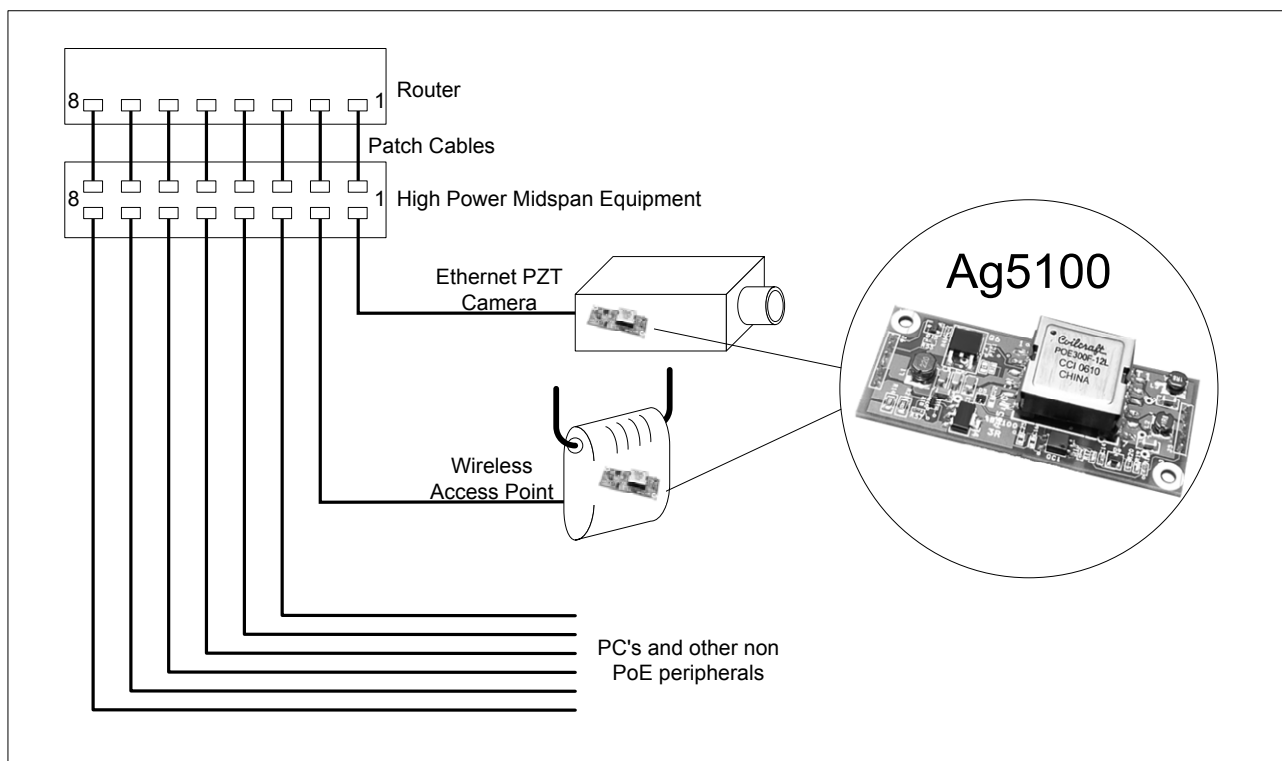

**Figure 9: Typical Application**

## 7 Typical Recommendations

Figure 10: Typical Layout gives an example of the tracking needed for the Ag5100. C1, C2 and C3 must be positioned as close to the output pins as possible.

Opto1 (PC817 or equivalent) is required for Type 2 PSE detection.

RA1 or RA2 can be fitted if output voltage adjustment is required.

To maintain the 1500Vdc isolation barrier do not route track in the keep out area.

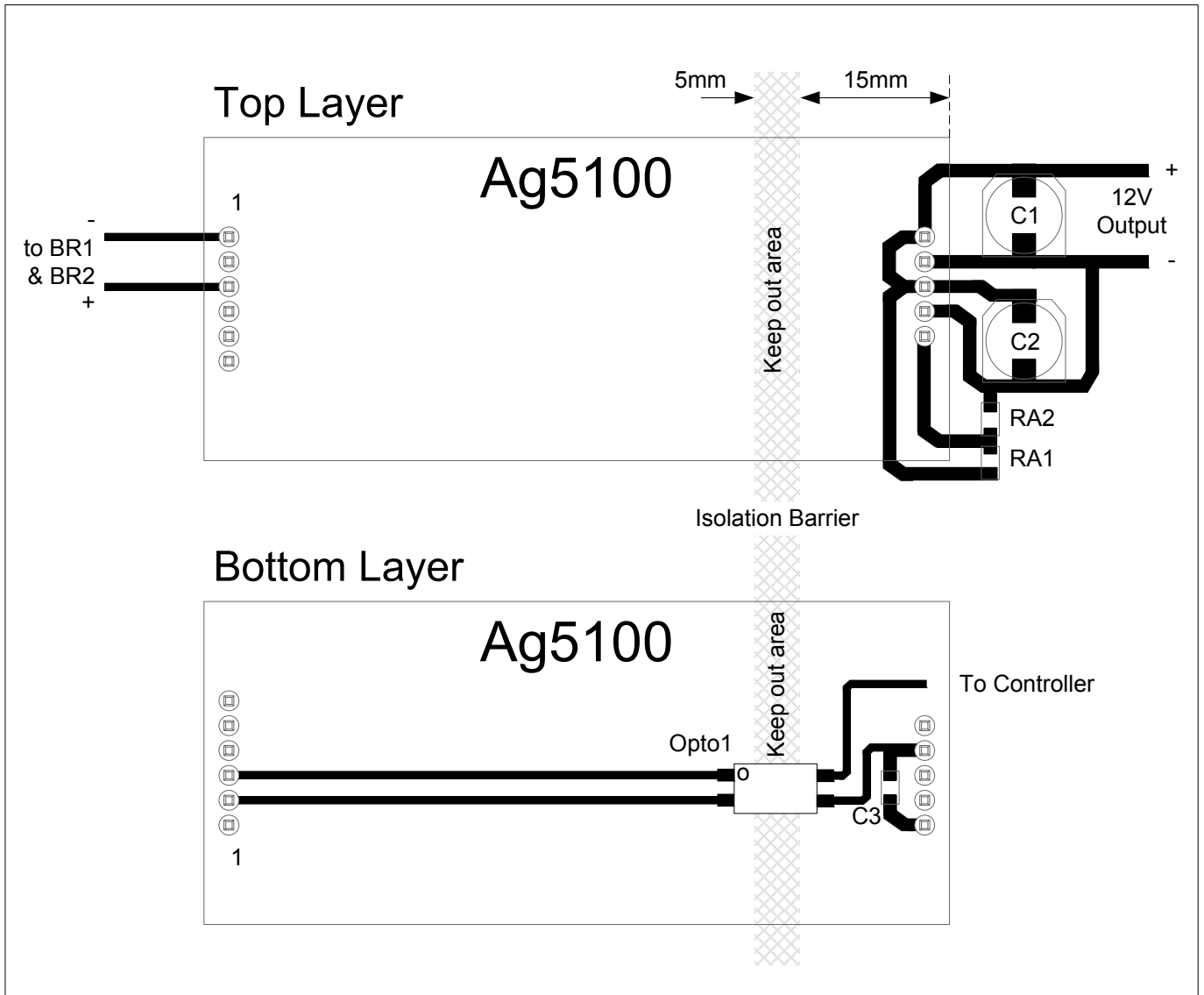

**Figure 10: Typical Layout**

## 8 Operating Temperature Range

Because the Ag5100 is a power component, it will generate heat, so it is important that this be taken into consideration at the design stage.

At the heart of the Ag5100 is a DC/DC converter, which like any other power supply will generate heat. The amount of heat generated by the module will depend on the load it is required to drive and the input voltage supplied by the PSE. The information shown within this section of datasheet is referenced to a single nominal 48Vdc input voltage supplied by the PSE.

The Ag5100 has a maximum ambient operating temperature of 70°C see Figure 11. These results are in still air without any heatsinking. The performance of the Ag5100 can be

improved by forcing the airflow over the part or by using a heatsink (the Ag5100 has two heatsink mounting locations, as shown in Section 11.1).

The output stage of the Ag5100 has a built-in thermal protection circuit, to prevent the module from being damaged if operated beyond its power / temperature specification.

Because each application is different it is impossible to give fixed and absolute thermal recommendations. However it is important that any enclosure used has sufficient ventilation for the Ag5100 and a direct airflow if possible.

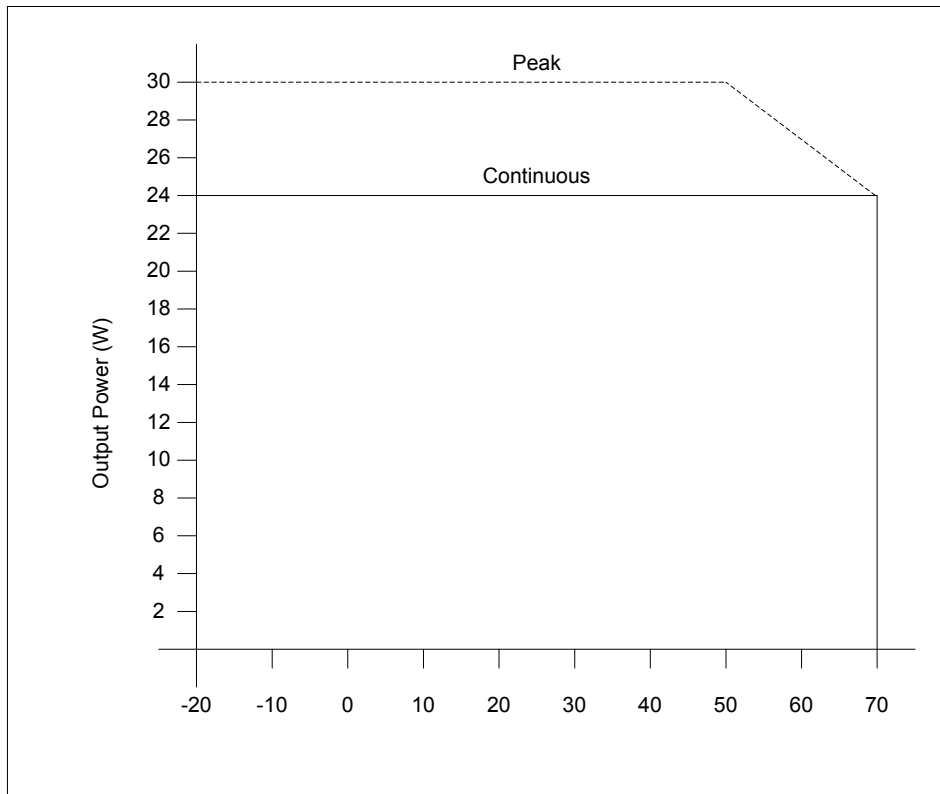

**Figure 11: Ag5100 Operating Profile**

## 9 Protection

The Ag5100 must be protected from over-voltages exceeding the 80V maximum rated surge input voltage. An inexpensive but effective solution can be achieved by connect Tranzorb diodes across each of the inputs; see Apps Note “ANX-POE-Protection”.

## 10 Electrical Characteristics

### 10.1 Absolute Maximum Ratings<sup>1</sup>

	Parameter	Symbol	Min	Max	Units
1	DC Supply Voltage	V <sub>CC</sub>	-0.3	60	V
2	DC Supply Voltage Surge for 1ms	V <sub>SURGE</sub>	-0.6	80	V
3	Storage Temperature	T <sub>S</sub>	-40	+100	°C

Note 1: Exceeding the above ratings may cause permanent damage to the product. Functional operation under these conditions is not implied. Maximum ratings assume free airflow.

### 10.2 Recommended Operating Conditions

	Parameter	Symbol	Min	Typ	Max	Units
1	Input Supply Voltage <sup>1</sup>	V <sub>IN</sub>	36	48	57	V
2	Under Voltage Lockout	V <sub>LOCK</sub>	30		36	V
3	Operating Temperature <sup>2</sup>	T <sub>OP</sub>	-20	25	70	Ta / °C

Note 1: With minimum load

2: See Section Operating Temperature Range

### 10.3 DC Electrical Characteristics

	DC Characteristic	Sym	Min	Typ <sup>1</sup>	Max	Units	Test Comments
1	Nominal Output Voltage	+VDC	11.4 22.8	12 24	12.6 25.2	V V	Parallel O/P Series O/P
2	Voltage Adjust Range	V <sub>ADJ</sub>	10.7		26.7	V	See Output Adjustment
3	Output Current <sup>2</sup> (V <sub>IN</sub> = 48V)	I <sub>OUT</sub>			2.5 1.25	A A	Parallel O/P Series O/P
4	Line Regulation	V <sub>LINE</sub>		0.1		%	@ 50% Load
5	Load Regulation	V <sub>LOAD</sub>		1.5		%	@ V <sub>IN</sub> =48V
6	Output Ripple and Noise	V <sub>RN</sub>		130		mVp-p	@ Max load <sup>3</sup>
7	Minimum Load	R <sub>LOAD</sub>	100			mA	
8	Short-Circuit Duration	T <sub>SC</sub>			∞	sec	
9	Efficiency	EFF		86		%	V <sub>in</sub> = 48V 50% Load
10	Isolation Voltage (I/O)	V <sub>ISO</sub>			1500	V <sub>PK</sub>	Impulse Test

Note 1: Typical figures are at 25°C with a nominal 48V supply, parallel output configuration (unless otherwise stated) and are for design aid only. Not Guaranteed

2: The output must not exceed 30W or 2.5A Parallel / 1.25A Series.

3: The output ripple and noise can be reduced with an external filter, see application note.

## 11 Package

### 11.1 Ag5100

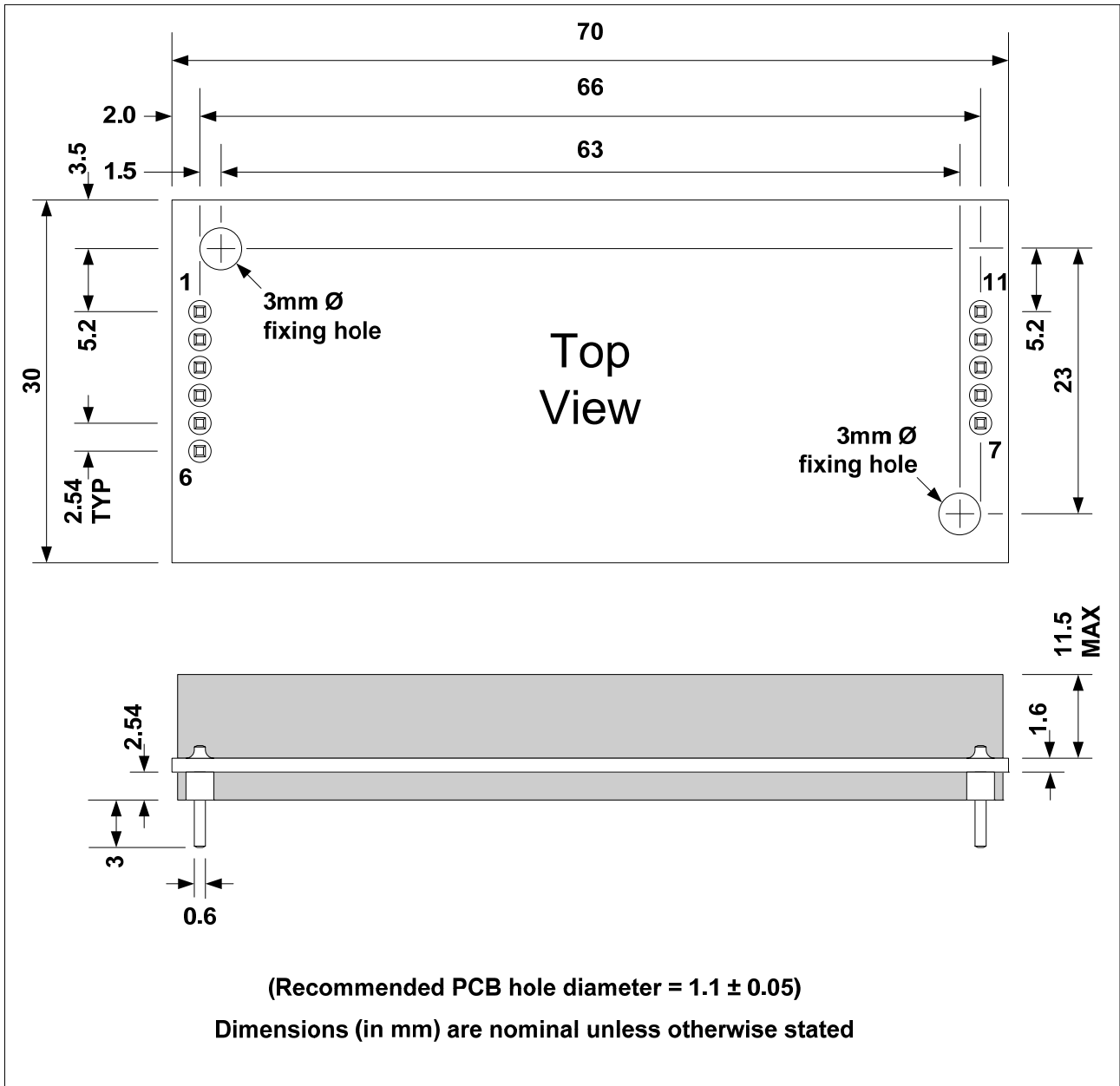

Information published in this datasheet is believed to be correct and accurate. Silver Telecom assumes no liability for errors which may occur or for liability otherwise arising out of use of this information or infringement of patents which may occur as a result of such use. No license is granted by this document under patents owned by Silver Telecom or licensed from third parties by Silver Telecom. The products, their specification and information appearing in this document are subject to change by Silver Telecom without notice.