

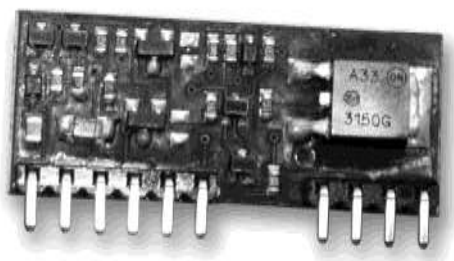

Ag5500-FE

PoE Front End Module



1. Features

- Small size SIL package
- Input voltage range 36V to 57V
- IEEE802.3af and IEEE802.3at compliant inputs
- 60W Maximum Power
- Designed for POE Lighting and POE Extender applications
- Minimal (low cost) external components required
- Silvertel "design-in" assistance

2. Description

The Ag5500-FE has been designed to extract power from Power Sourcing Equipment (PSE) over an Ethernet cable and pass this straight through to its output pins for maximum efficiency. The module's input conforms to the IEEE 802.3af standard for signature recognition and class programming. It has been designed to work with existing high power PSE's from leading manufacturers.

Ag5500-FE is perfect for applications such as POE Lighting, PoE extenders and repeaters.

Table of Contents

1. Features	1
2. Description.....	1
Table of Contents	2
Table of Figures	2
3. Ag5500-FE Product Selector	3
4. Pin Description	4
5. Functional Description	5
5.1 Inputs	5
5.2 PD Signature	5
5.3 Power Classification	6
5.4 Input configuration.....	7
5.5 Under Voltage Lockout (UVLO) Protection.....	7
5.6 Output Voltage	7
5.7 Typical Connections	8
6. Protection.....	9
7. Electrical Characteristics.....	9
7.1 Absolute Maximum Ratings ¹	9
7.2 Recommended Operating Conditions	9
7.3 DC Electrical Characteristics.....	9
8. Package.....	10

Table of Figures

Figure 1: Block Diagram	3
Figure 2: Ag5500-FE Package Format	3
Figure 3: Typical System Diagram.....	5
Figure 4: Class Programming Option.....	6
Figure 5: Input Power configuration	7
Figure 6: Typical POE LED Lighting Connection Diagram.....	8
Figure 7: Typical POE Extender Connection Diagram.....	8

3. Ag5500-FE Product Selector

Part Number†	Maximum Power *
Ag5500-FE	60W

*At 25°C must include adequate thermal management

† The Ag5500-FE fully meets the requirements of the RoHS directive 2002/95/EC on the restriction of hazardous substances in electronic equipment.

‡ Voltage depending on output configuration (Parallel or Series), see Section 5.7.

Table 1: Ordering Information

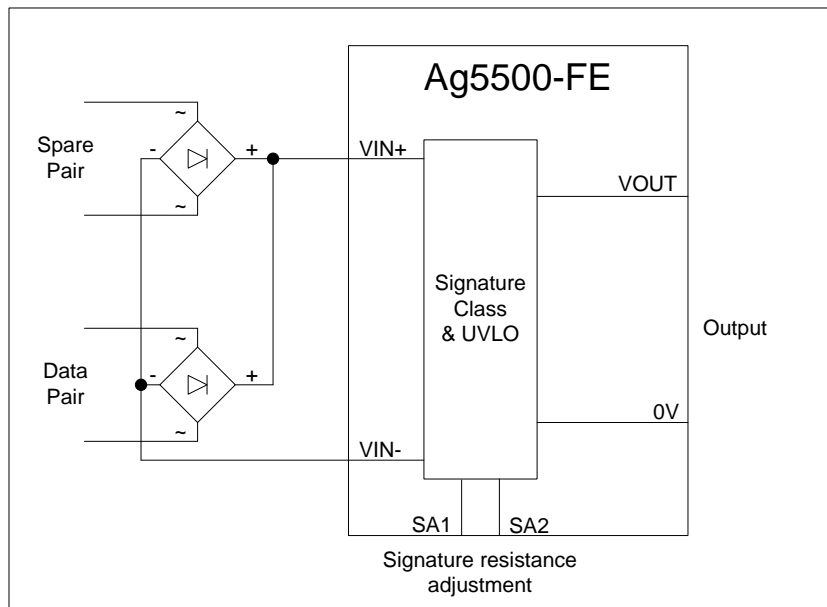

Figure 1: Block Diagram

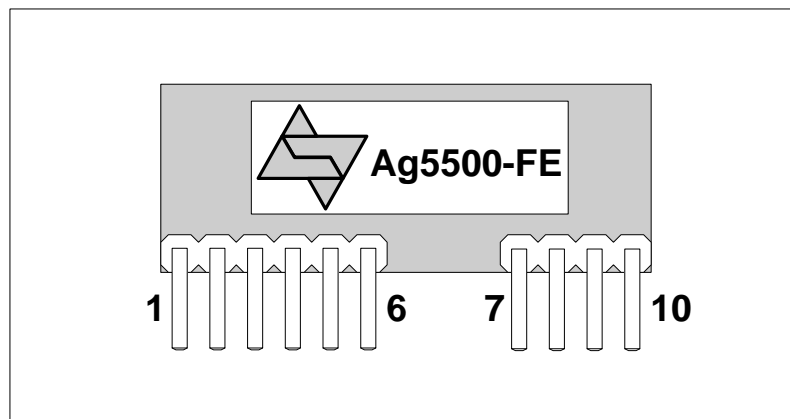

Figure 2: Ag5500-FE Package Format

4. Pin Description

Pin #	Name	Description
1	VIN+	Direct Input +. This pin connects to the positive (+) output of the input bridge rectifier.
2	VIN-	Direct Input -. This pin connects to the negative (-) output of the input bridge rectifier.
3	CPA	Class Programming. By Default the Ag5500-FE classification is set to Class 4. But by connecting an external 360R resistor from this pin to VIN- the classification can be increased to Class 5.
4	NC	Reserved
5	SA1	Signature Adj. There are several high power PSE units that require a 12.5K signature. Connecting this pin to SA2 will offset the Ag5500-FE signature to be compatible with these PSEs.
6	SA2	Signature Adj. There are several high power PSE units that require a 12.5K signature. Connecting this pin to SA1 will offset the Ag5500-FE signature to be compatible with these PSEs.
7 & 8	VOUT	DC Output. This pin is internally connected to the VIN+ input.
9 & 10	0V	Ground. The pin is the switched ground return for the VOUT output pin. It only turns on when the main PSE power is applied to the input pins.

5. Functional Description

5.1 Inputs

The Ag5500-FE has a single input that can be connected to two external bridge rectifiers (see Figure 1: Block Diagram). This allows the Ag5500-FE to be compatible with equipment that uses the different power options, see Figure 5: Input Power Options.

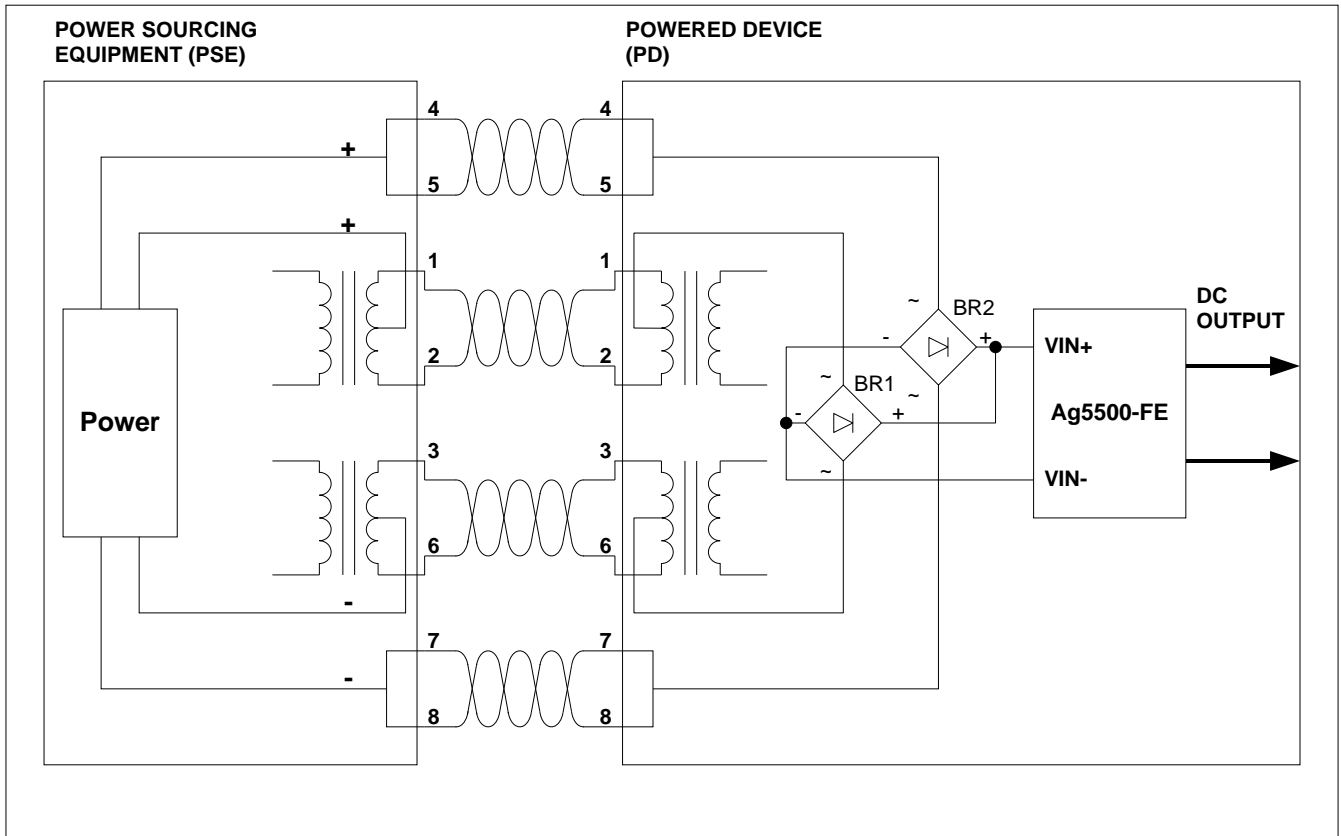

Figure 3: Typical System Diagram

5.2 PD Signature

The Ag5500-FE input complies with the IEEE802.3af specification. When the inputs are connected to a Power Sourcing Equipment (PSE), they will automatically present a Powered Device (PD) signature to the PSE (when requested). The equipment will then recognise that a PD is connected to that line and supply power.

The SA1 and SA2 pins must be connected together when used with a Pihong POE80U or POE60U PSE.

5.3 Power Classification

By Default the Ag5500-FE classification is set to Class 4. But by connecting an external 360R resistor from the CP pin to VIN- pin the classification can be increased to Class 5.

CLASS	Programming Resistance (Ohms)
4	Do not fit
5	360 \pm 1%

Table 2: Class Programming

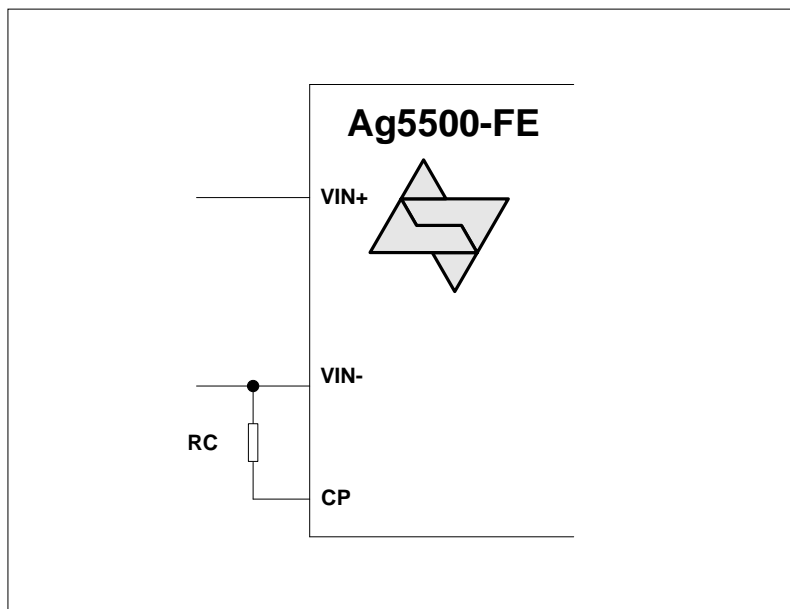

Figure 4: Class Programming Option

5.4 Input configuration

To get maximum power the Ag5500-FE's must be configured to accept inputs from both the spare pair and data pair as shown in Figure 3: Typical System Diagram and Figure 5: Input Power Configuration.

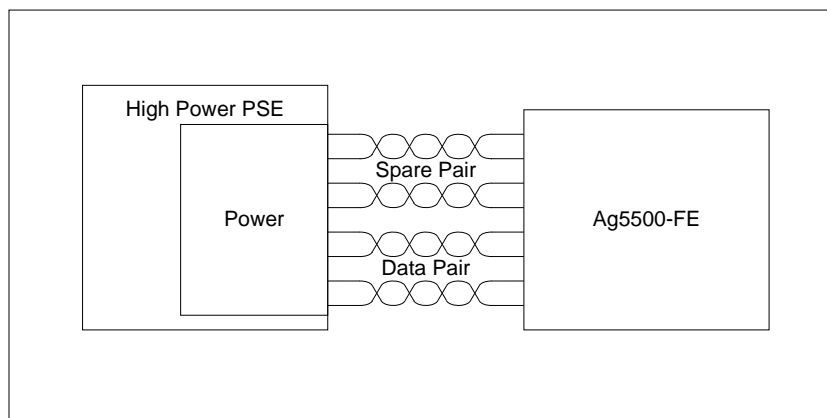

Figure 5: Input Power configuration

5.5 Under Voltage Lockout (UVLO) Protection

The Ag5500-FE has an on-board UVLO circuit that prevents the output from turning on until the PSE supplies its main output voltage to the module.

5.6 Output Voltage

The PSEs main output voltage will be switched through to the Ag5500-FE output. It is important to remember that the Ag5500-FE module is NON-ISOLATED and the 0V output pin cannot be connected to the VIN- pin. Connecting these pins together will result in the modules failure to operate correctly.

5.7 Typical Connections

Figure 6 shows how the Ag5500-FE can be connected to an Ag201 for a Low voltage POE LED lighting solution.

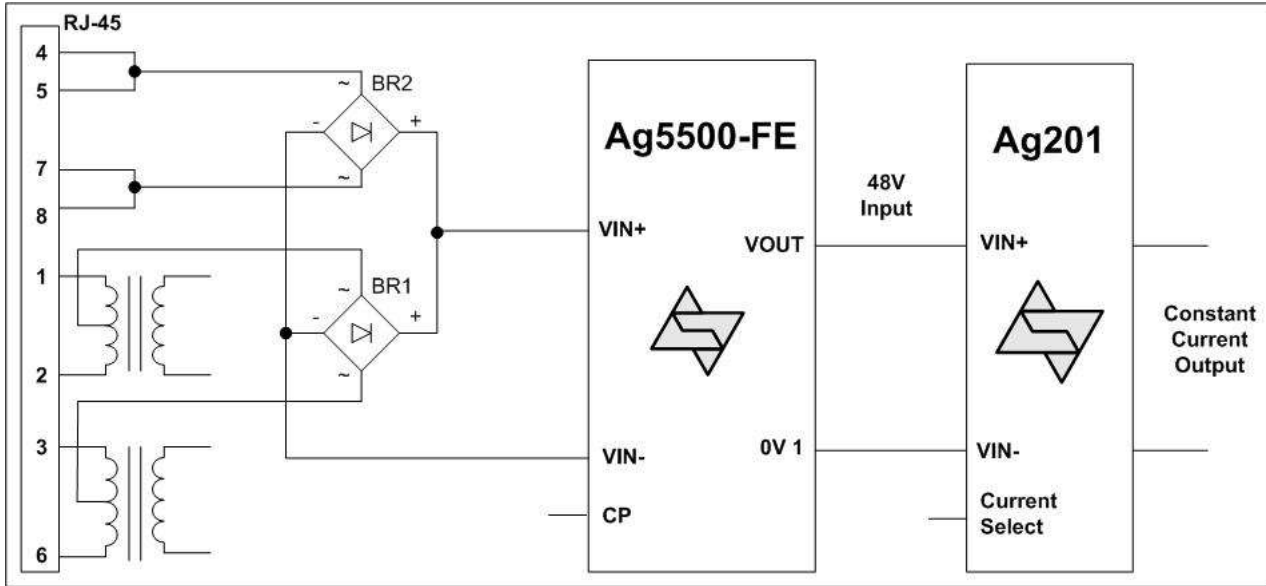

Figure 6: Typical POE Lighting Connection Diagram

Figure 7 shows how the Ag5500-FE can be connected to an Ag6100 or Ag6110 to make a PoE extender or POE repeater.

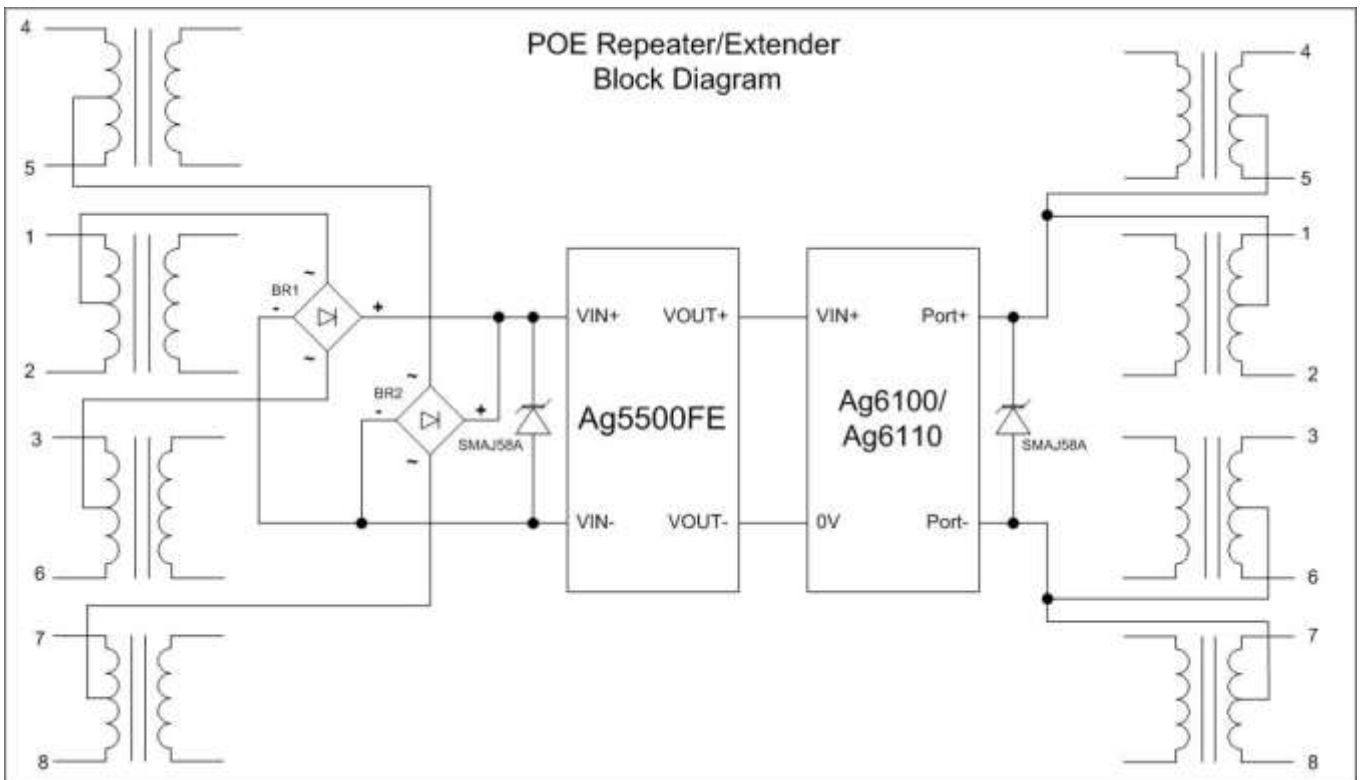

Figure 7: Typical POE Extender Connection Diagram

6. Protection

The Ag5500-FE must be protected from over-voltages exceeding the 80V maximum rated surge input voltage. An inexpensive but effective solution can be achieved by connect Tranzorb diodes across the modules input pins; see Apps Note “ANX-POE-Protection”.

Note: The Ag5500-FE does not have output short-circuit protection.

7. Electrical Characteristics

7.1 Absolute Maximum Ratings¹

	Parameter	Symbol	Min	Max	Units
1	DC Supply Voltage	V_{CC}	-0.3	60	V
2	DC Supply Voltage Surge for 1ms	V_{SURGE}	-0.6	80	V
3	Storage Temperature	T_S	-40	+100	°C

Note 1: Exceeding the above ratings may cause permanent damage to the product. Functional operation under these conditions is not implied. Maximum ratings assume free airflow.

7.2 Recommended Operating Conditions

	Parameter	Symbol	Min	Typ	Max	Units
1	Input Supply Voltage @ 60W @ 20W	V_{IN}	52 36		57 57	V V
2	Under Voltage Lockout	V_{LOCK}	30		36	V
3	Operating Temperature ¹	T_{OP}	-40	25	85	$T_a / ^\circ C$

Note 1: See Section operating temperature range

7.3 DC Electrical Characteristics

	DC Characteristic	Sym	Min	Typ ¹	Max	Units	Test Comments
1	Minimum Load	I_{MIN}	10			mA	
2	Efficiency	Eff		99		%	

Note 1: Typical figures are at 25°C and are for design aid only. Not Guaranteed

