

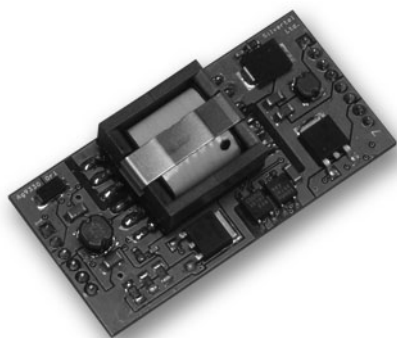

# Ag9330

30W PoE Module for Security  
Cameras and Systems



## 1 Features

- Triple Input module for POE, 12Vdc and 24Vac
- IEEE802.3at and IEEE802.3af compliant
- Dual In-Line (DIL) package size – 60mm (L) x 30mm (W)
- Overload and short-circuit protection
- Adjustable Output
- Thermal Cut Off
- Single High efficiency DC/DC converter
- 1500Vdc isolation (input to output)
- Silvertel “design-in” assistance

## 2 Description

The Ag9330 Power-over-Ethernet (PoE) module is designed to extract power from a conventional twisted pair Category 5 Ethernet cable, conforming to the IEEE 802.3at PoE standard. With two additional auxiliary inputs, one for an auxiliary DC supply and the other for an auxiliary AC supply.

This module is ideal for security cameras where 12Vdc or 24Vac is used.

The Ag9330 has been designed to extract power from Power Sourcing Equipment (PSE) over a conventional twisted pair Category 5 Ethernet cable. The modules input conform to the IEEE803.2at standard for signature recognition and class programming.

The high efficiency DC/DC converter operates over a wide input voltage range with a low ripple and low noise output. The DC/DC converter also has built-in output overload, output short-circuit and over-temperature protection and provides a 1500Vdc (input to output) isolation barrier.

### Table of Contents

1	Features .....	1
2	Description.....	1
	Table of Contents.....	2
	Table of Figures .....	2
3	Ag9330 Product Selector† .....	3
4	Pin Description .....	4
5	Functional Description .....	5
5.1	Inputs.....	5
5.2	PD Signature .....	6
5.3	Isolation .....	6
5.4	Power Classification .....	6
5.5	AT Detection.....	7
5.6	DC/DC Converter .....	8
5.7	Output Adjustment.....	8
5.8	Typical Connections .....	9
5.9	Output Power.....	11
6	Typical Application.....	11
7	Operating Temperature Range.....	12
8	Protection .....	13
9	Electrical Characteristics .....	14
9.1	Absolute Maximum Ratings*.....	14
9.2	Recommended Operating Conditions.....	14
9.3	DC Electrical Characteristics* .....	15
10	Package .....	16

### Table of Figures

Figure 1:	Block Diagram .....	3
Figure 2:	Ag9330 DIL Package Format.....	5
Figure 3:	Typical System Diagram.....	6
Figure 4:	Two Event Physical Layer Detect Configuration .....	7
Figure 5:	Output Adjustment.....	8
Figure 6:	Typical PoE Only Connection Diagram.....	9
Figure 7:	Typical PoE and Auxiliary Input Connection Diagram.....	10
Figure 8:	Minimum DC voltage at the AUX1 input .....	11
Figure 9:	Typical Application.....	12
Figure 10:	Ag9330 Operating Profile .....	13

### 3 Ag9330 Product Selector†

Part Number	Nominal Output Voltage	Maximum Output Power *	Marking	Package
Ag9330-D	12V	30 Watts	12	DIL

\*At 25°C with  $V_{IN} = 52V$

† The Ag9330 fully meets the requirements of the RoHS directive 2002/95/EC on the restriction of hazardous substances in electronic equipment.

**Table 1: Ordering Information**

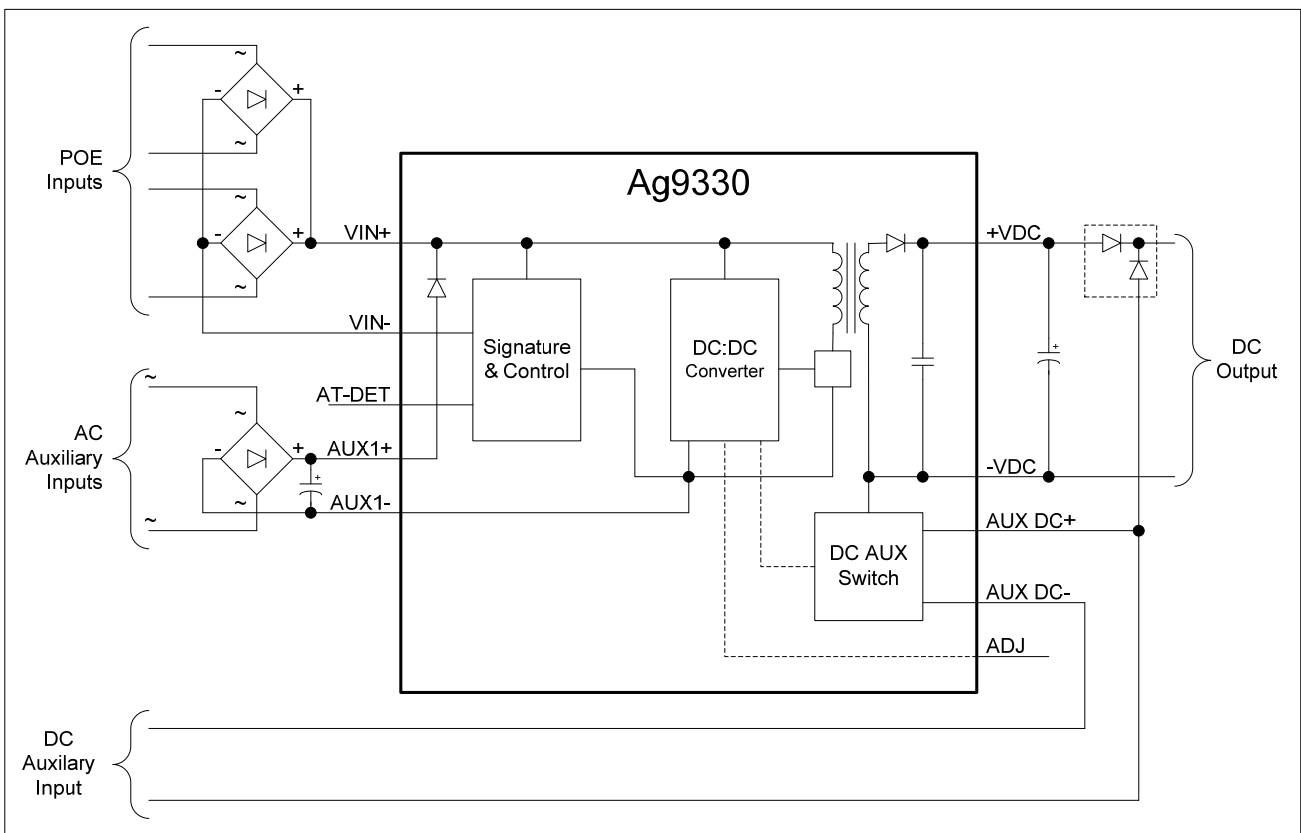

Figure 1: Block Diagram

### 4 Pin Description

Pin #	Name	Description
1	AUX1-	<b>AUX Supply Input -.</b> This pin connects to the negative (-) output of an auxiliary AC supply bridge rectifier.
2	AUX1+	<b>AUX Supply Input +.</b> This pin connects to the positive (+) output of an auxiliary AC supply bridge rectifier.
3	VIN+	<b>POE Direct Input +.</b> This pin connects to the positive (+) output of the POE input bridge rectifiers.
4	NC	<b>No Connection.</b> Do not connect to this pin.
5	AT-DET	<b>AT Detect Output.</b> This pin indicates if an IEEE802.3at PSE is supplying power to the Ag9330, see Section 5.5 for more details.
6	VIN-	<b>POE Direct Input -.</b> This pin connects to the negative (-) output of the POE input bridge rectifiers.
7	AUX DC-	<b>AUX DC Supply Input -.</b> This pin connects to the negative (-) auxiliary DC power supply.
8		
9	-VDC	<b>Negative DC Output.</b> This pin provides the negative regulated output from the Ag9330.
10		
11	ADJ	<b>Output Adjust.</b> The output voltage can be adjusted from its nominal value, by connecting an external resistor from this pin to either the +VDC pin or the -VDC pin.
12	+VDC	<b>Positive DC Output.</b> This pin provides the positive regulated output from the Ag9330.
13		
14	AUX DC+	<b>AUX DC Supply Input +.</b> This pin connects to the positive (+) output of an auxiliary DC supply.

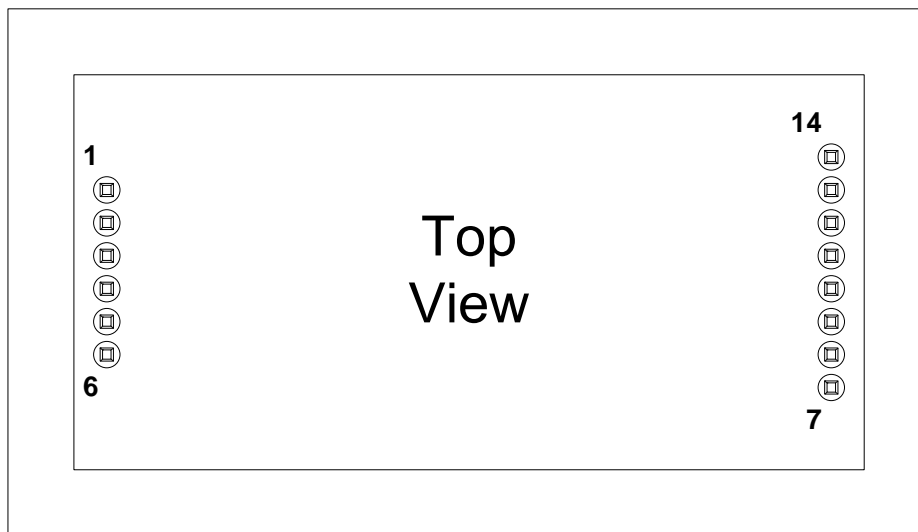

Figure 2: Ag9330 DIL Package Format

## 5 Functional Description

### 5.1 Inputs

The Ag9330 has three inputs: -

The VIN input pins are for PoE and are connected to two external bridge rectifiers, see Figure 3. This allows the Ag9330 to be compatible with power sourcing equipment that uses the different power options (power on the Data Pair or power on the Spare Pair).

The AUX1 input pins are for the Auxiliary AC supply and are connect to an external bridge rectifiers and smoothing capacitor (recommended 1000 $\mu$ F).

The AUX DC input pins connect to an external DC supply and is configured as shown in Figure 3.

When the Ag9330 is being powered by PoE (at the VIN input) and then power is applied to the AUX1 input. If the AUX1 voltage is greater than the PoE voltage, then it will take over and disable the PoE input. However if the AUX1 voltage is less than the PoE voltage, the PoE input will retain priority.

When the Ag9330 is being powered form the AUX1 input, the PoE signature at the VIN input will be disabled. This means that PoE mode cannot be made if AUX1 is connected first.

The PoE (VIN) and AUX1 inputs both have priority over the AUX DC input.

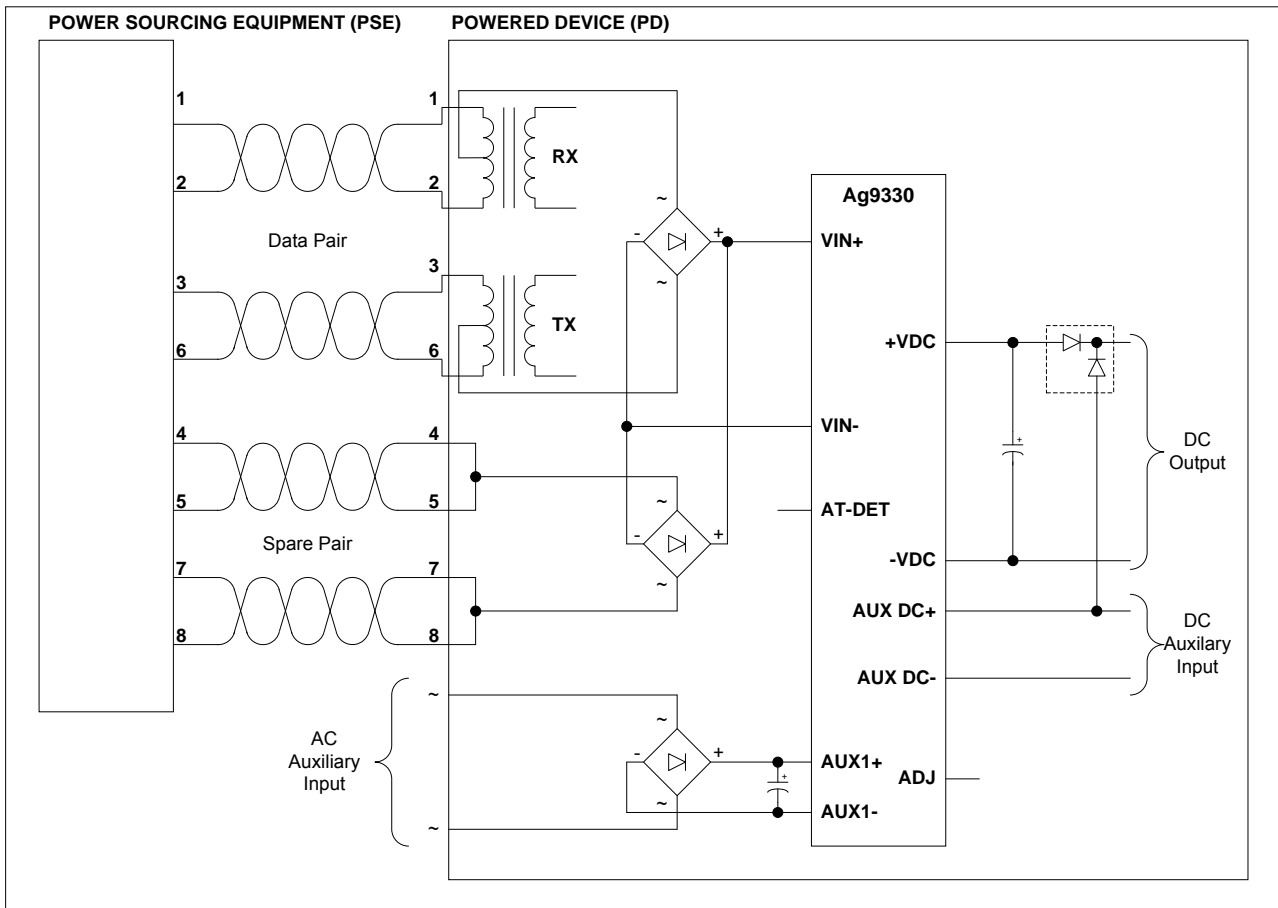

Figure 3: Typical System Diagram

### 5.2 PD Signature

When the Ag9330 VIN input is connected to the Cat 5e cable, it will automatically present a Powered Device (PD) signature to the PSE, when requested. The PSE will recognise that a PD is connected to that line and supply power.

### 5.3 Isolation

To meet the safety isolation requirements of IEEE802.3at section 33.4.1 a PD must pass the electrical strength test of IEC 60950-1:2001 sub clause 6.2.1. This calls for either a) 1500Vac test or b) 2250Vdc test or c) 1500Vdc impulse test. The Ag9330 has been designed to meet c) 1500Vdc impulse test.

### 5.4 Power Classification

The Ag9330 classification is fixed at Class 4, this means that an IEEE802.3at Type 1 or an IEEE802.3af PSE will default to Class 0. However an IEEE802.3at Type 2 PSE will recognise Class 4 as a Type 2 PD.

### 5.5 AT Detection

The Ag9330 has an AT-DET output pin which is used to detect a Two Event Physical Layer classification as described in IEEE802.3at. If required the AT-DET pin can be connected directly to an opto-coupler as shown in Figure 4.

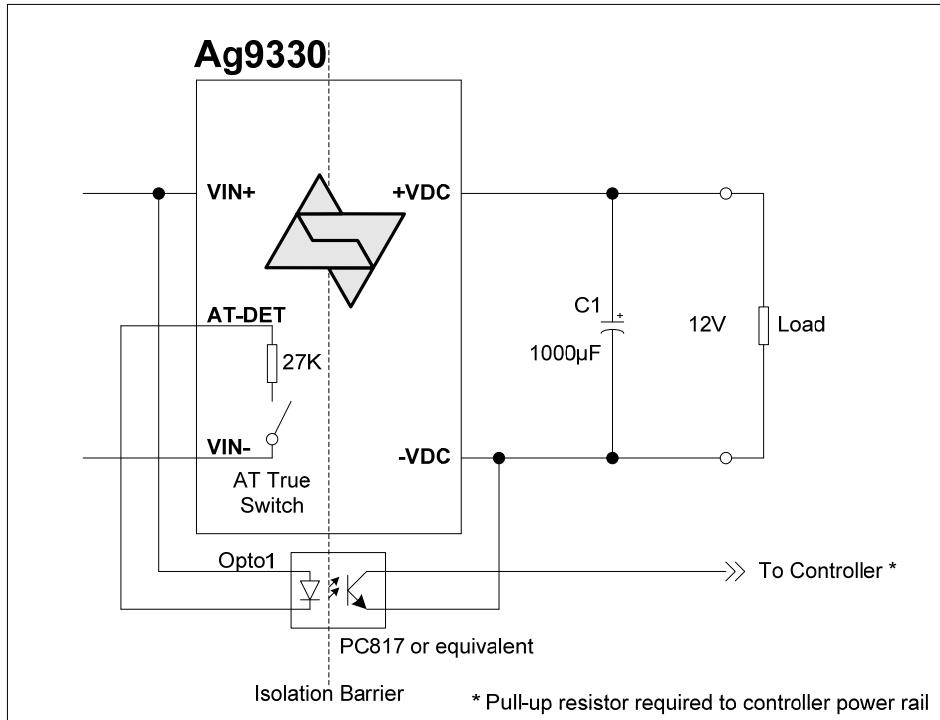

Figure 4: Two Event Physical Layer Detect Configuration

If the Ag9330 detects a Two Event Physical Layer classification, the (AT True) switch will close and Opto1 will turn ON. Opto1 will be connected across the isolation barrier and the output collector can be connected to a controller (with a pull-up resistor connected to the controller's power rail). When Opto1 is ON the collector (output) will be Logic 0, the controller will then know that the PSE is capable of delivering over 15.4W. To complete the protocol the controller should then confirm that it is a Type 2 PD over the Data Link Layer\*.

If the Ag9330 detects a Single Event Physical Layer classification, Opto1 will be OFF and the output collector will be Logic 1 (via pull-up resistor). The controller should then assume that the PSE is limited to delivering up to 15.4W.

If the PSE does not support the Physical Layer classification, Opto1 will be OFF.

The Ag9330 will operate with non IEEE802.3at compliant POE+ PSE's.

*\*Note: It is mandatory that the PD confirms that it is a Type 2 PD using the Data Link Layer. There are several PSE that will not delivery over 15.4W until they receives this confirmation.*

### 5.6 DC/DC Converter

The Ag9330's DC/DC converter provides a regulated 12V (nominal) output with low ripple and low noise. The DC/DC converter also has built-in output overload and short-circuit protection. The Ag9330 also has thermal protection; which will shutdown the DC/DC converter if triggered.

### 5.7 Output Adjustment

The Ag9330 has an ADJ pin, which allows the output voltage to be increased or decreased from its nominal value.

Figure 5 shows how the ADJ pin is connected: -

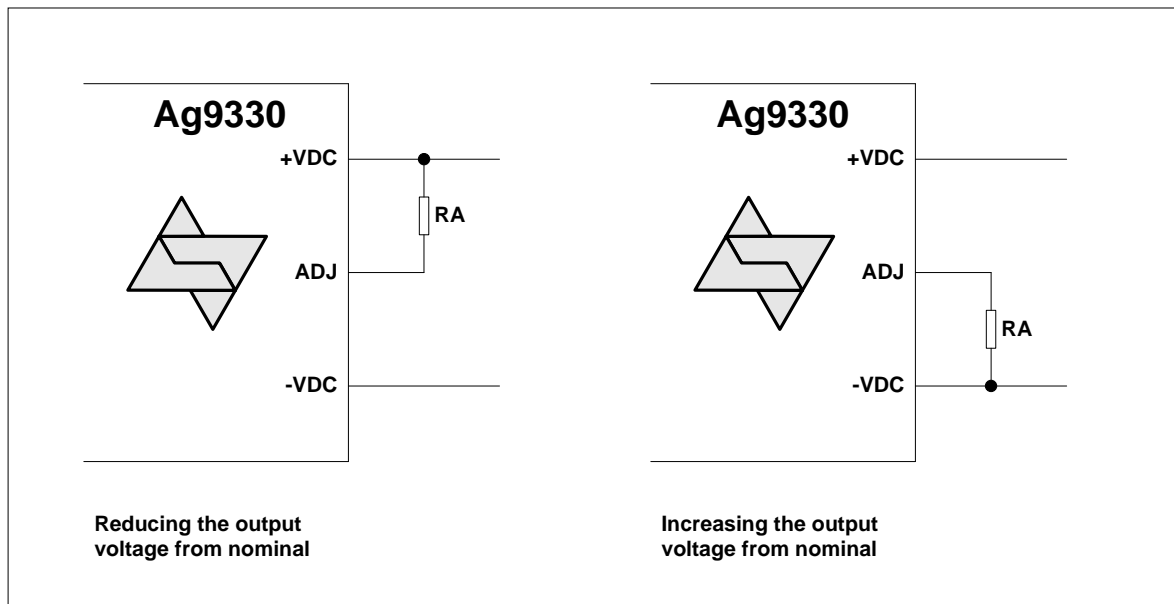

Figure 5: Output Adjustment

<b>Reducing the output voltage, connect RA between ADJ and +VDC</b>	
Value of RA	Ag9330 output
Open Circuit	12.0V
0 Ohms	9.7V
<b>Increasing the output voltage, connect RA between ADJ and -VDC</b>	
Value of RA	Ag9330 output
Open Circuit	12.0V
0 Ohms	12.75V

Table 2: Output Adjustment Resistor (R) Value



### 5.8 Typical Connections

The Ag9330 only requires a few external components - the bridge rectifiers on the VIN input are to conform to the IEEE802.3at input polarity protection requirement. The 1000 $\mu$ F capacitor (C1) connected across the output is needed for stability and to cope with load step changes. This can be a low cost electrolytic capacitor (a minimum of 1000 $\mu$ F 16V is recommended) as shown in Figure 6, this does not need to be a low ESR type for operation in temperatures down to 0°C. If ambient temperature is likely to go below 0°C then we would recommend a low ESR electrolytic capacitor.

The output voltage can be adjusted by simply connecting a resistor between the ADJ pin and either the +VDC Pin or the -VDC pin, see section 5.7 Output Adjustment.

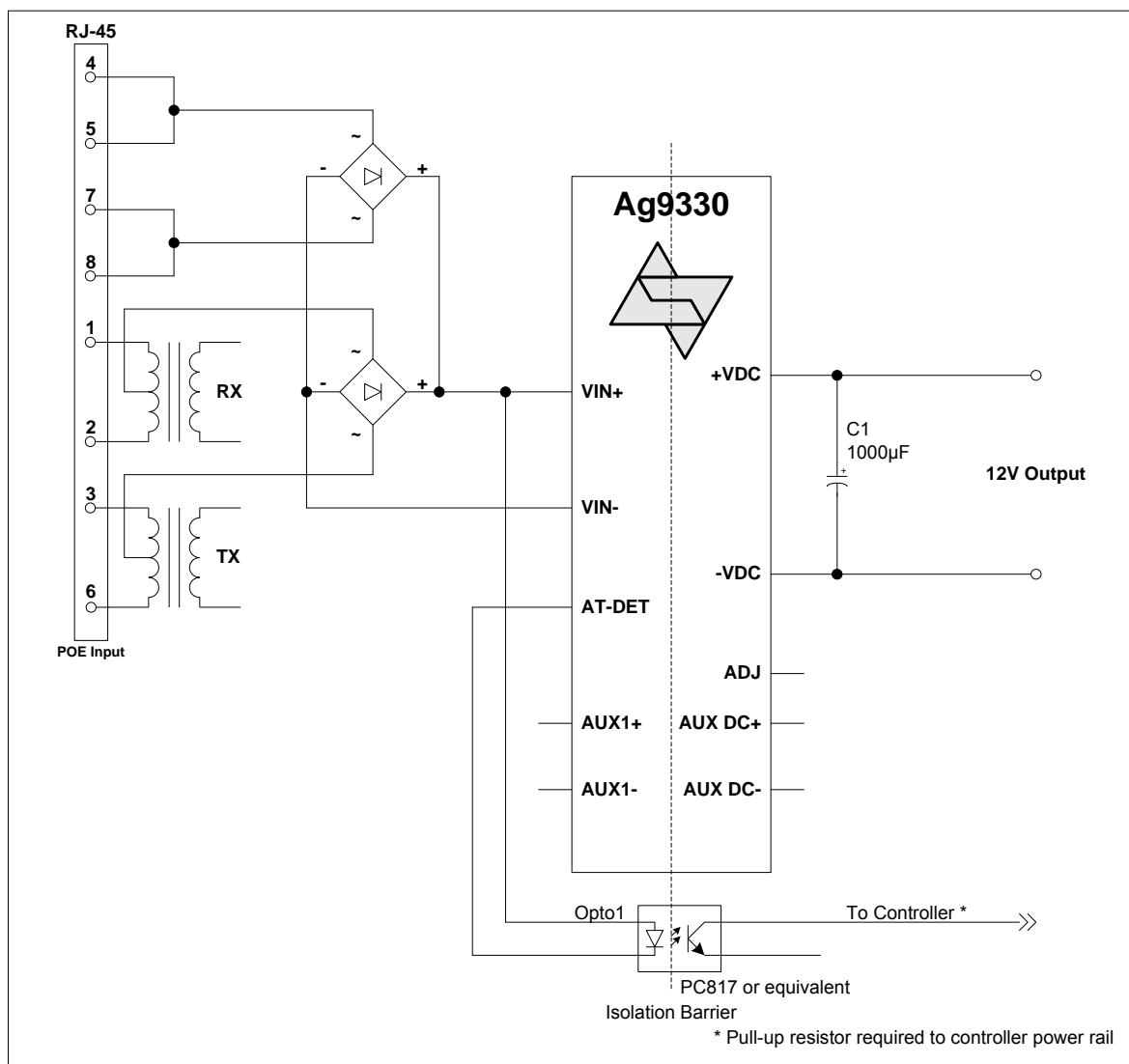

Figure 6: Typical PoE Only Connection Diagram

Figure 7 shows how to implement the two auxiliary inputs: -

The DC input requires two diodes to 'OR' with the +VDC output. R1 (0R) should be fitted to increase the Ag9330 output to compensate to the voltage drop of D1\*.

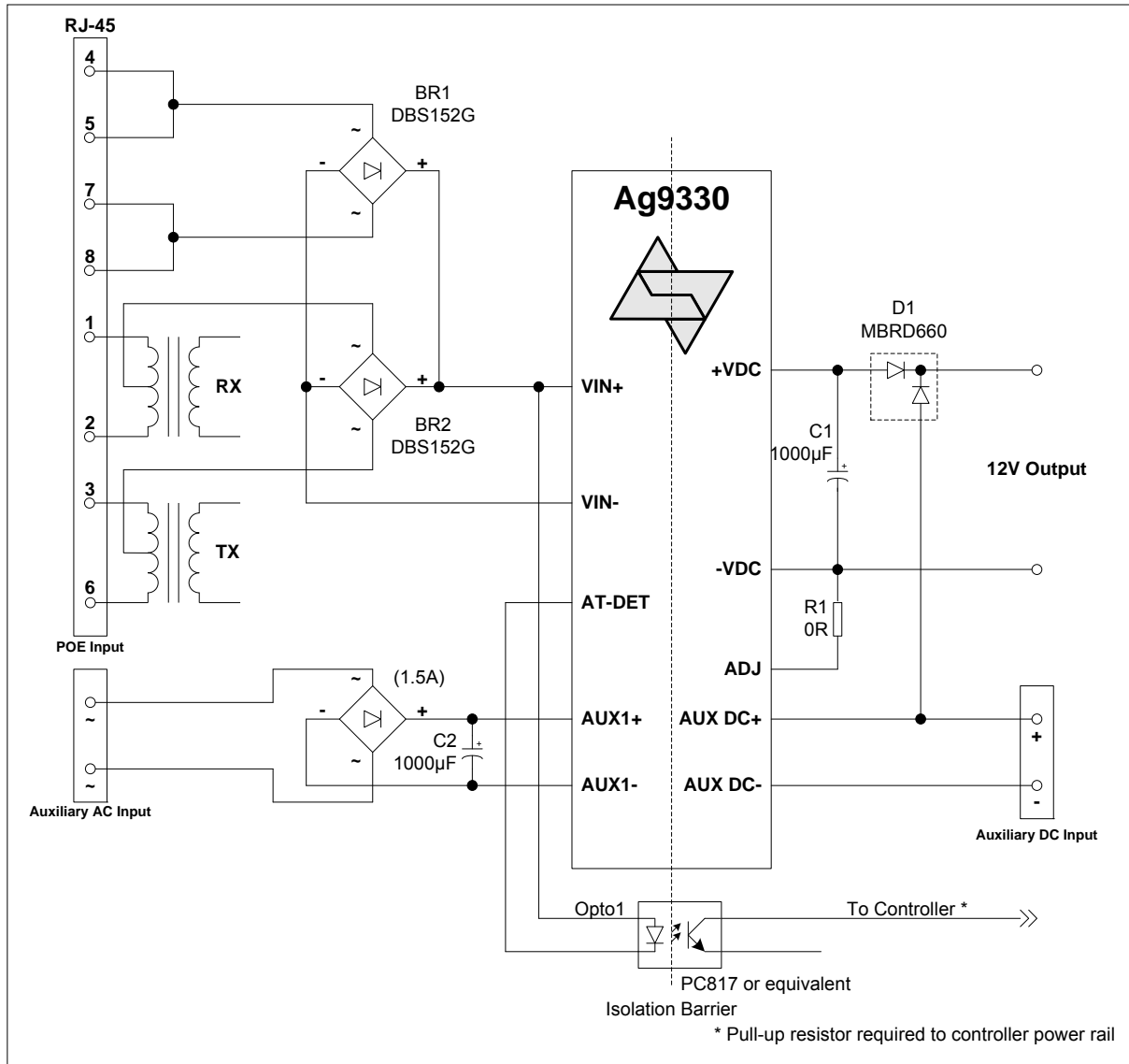

Figure 7: Typical PoE and Auxiliary Input Connection Diagram

*\*Note: The MBR660 suggested for D1 can be changed to two independent diodes or a higher specification dual diode if needed.*

The AC input requires an external bridge rectifier and 1000 $\mu$ F capacitor. The minimum ripple at the AUX1 input must not drop below 24V, see Figure 8. Additional capacitance may be required at higher loads (>15W) to prevent this from occurring.

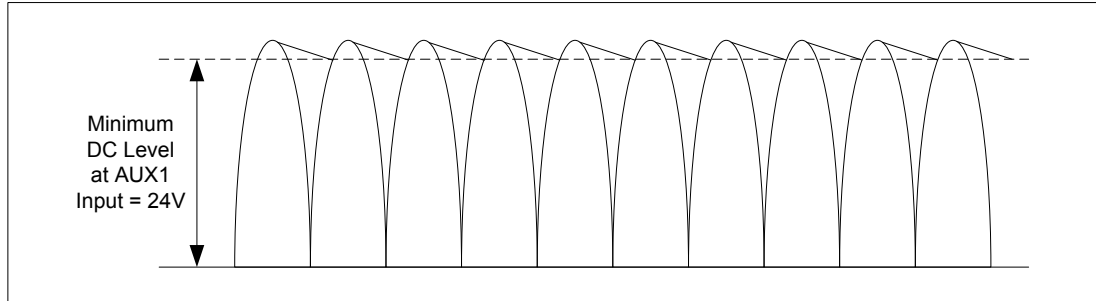

Figure 8: Minimum DC voltage at the AUX1 input

### 5.9 Output Power

The Ag9330 is capable of delivering a maximum output power of 30W continuous; however this is limited by the available input power and operating temperature.

When calculating the output power, the following factors must be taken into account: -

1. Ag9330 efficiency
2. PSE output power (which could be limited by the IEEE802.3at specification)
3. Cable and connector losses
4. Input bridge rectifier losses
5. Operating temperature

## 6 Typical Application

The Ag9330 can be used in numerous applications. In the example shown in Figure 9, the data outputs from the switch are connected to the inputs of a midspan. The midspan will then add power (to the data) on each output that supports POE.

In this example port 1 is connected to an ethernet camera and port 2 is connected to a wireless access point, both of these devices have a built-in Ag9330. When the midspan is switched on (or when the device is connected), the midspan will check each output for a POE signature. On ports 1 and 2 the Ag9330 will identify themselves as POE enabled devices and the midspan will supply both data and power to these peripherals.

The other ports (shown in this example) will not have a PoE signature and the midspan will only pass the data through to these peripherals. The midspan will continuously monitor each output to see if a POE enabled device has been added or removed.

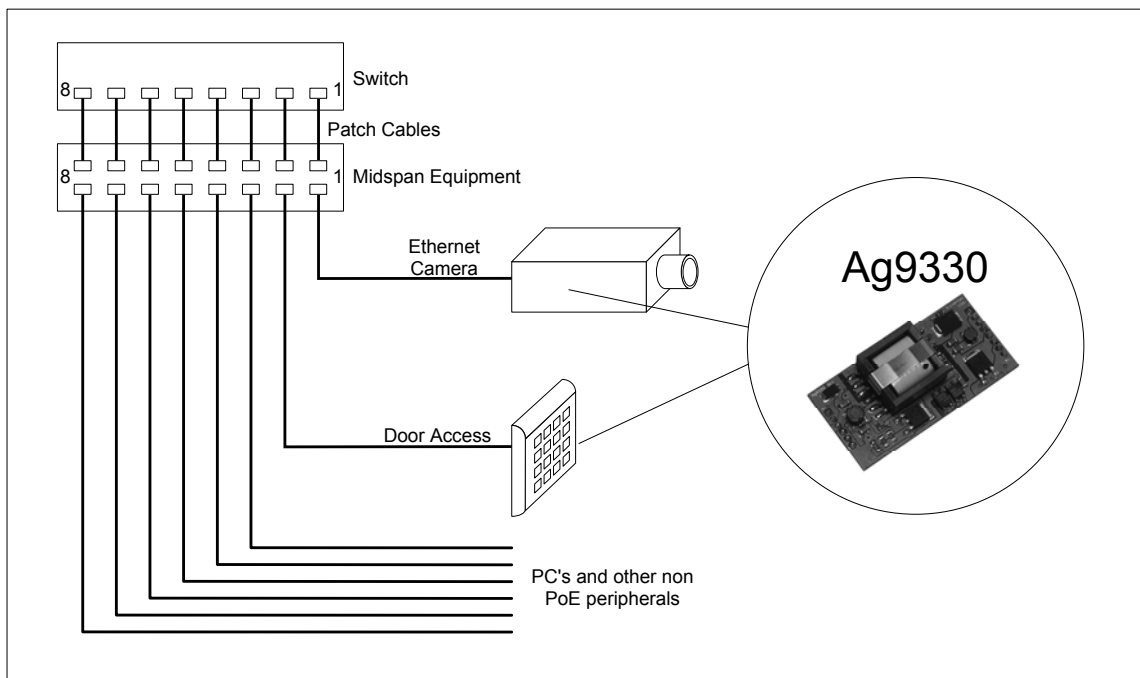

Figure 9: Typical Application

## 7 Operating Temperature Range

Because the Ag9330 is a power component, it will generate heat, so it is important that this be taken into consideration at the design stage.

The heart of the Ag9330 is a DC/DC converter, which like any other power supply will generate heat. The amount of heat generated by the module will depend on the load it is required to drive and the input voltage supplied by the PSE. The information shown within this section of datasheet is referenced to a nominal 52Vdc input voltage supplied by the PSE.

Because each application is different it is impossible to give fixed and absolute thermal recommendations. However to obtain maximum power it is important that any enclosure used has sufficient ventilation and forced airflow over the Ag9330.

When intended for used in ambient temperatures below 0°C we would recommend a low ESR electrolytic capacitor be used on the DC output. Capacitors rated for -55°C operation should be used below -20°C.

Figure 10 show the maximum ambient temperature under different load conditions. These figures have been recorded in an Associated Environment System SD-302 chamber (with circulating air). Operation in a sealed enclosure with limited airflow will result in de-rating of the operating temperature profile.

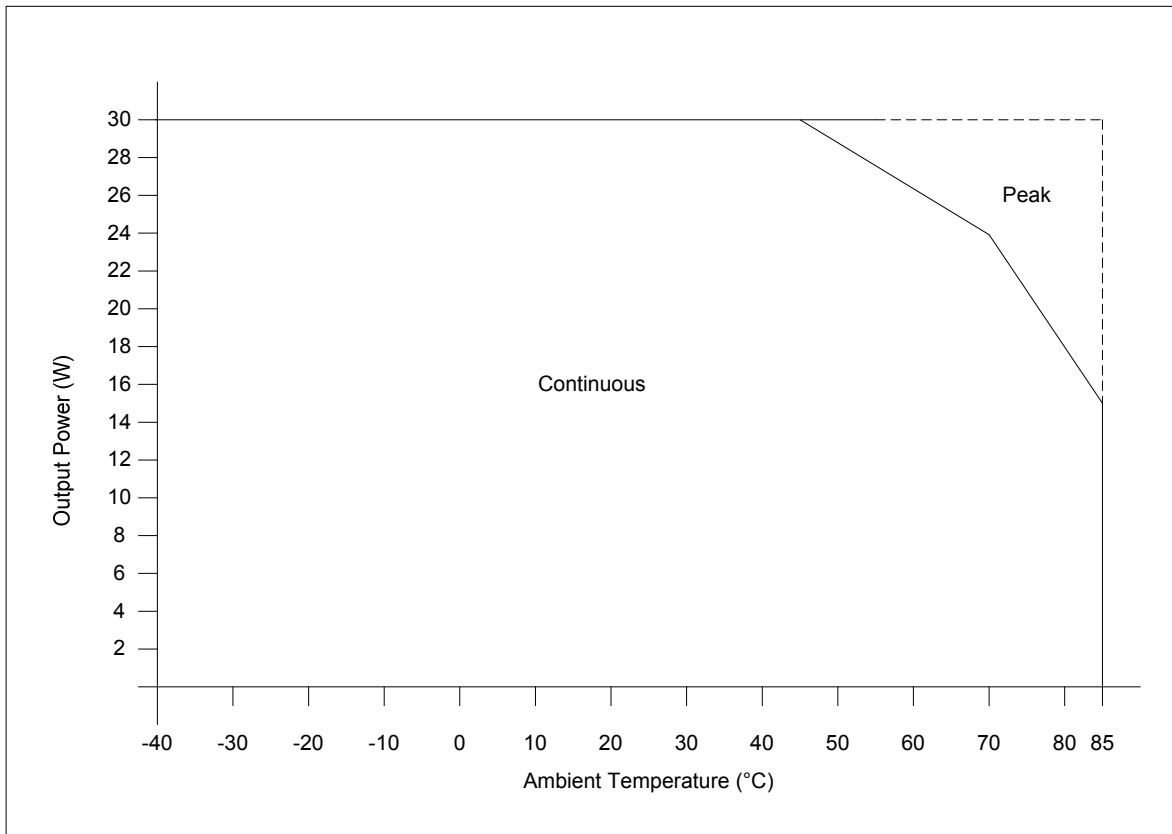

Figure 10: Ag9330 Operating Profile

## 8 Protection

The Ag9330 has built-in over-current and thermal protection to prevent the module from being damaged if operated beyond its power / temperature specification. If a short circuit is applied to the output the DC/DC converter will limit the current until the short circuit is removed. The thermal protection circuit will continue to disable the DC/DC converter until the Ag9330 temperature has cooled sufficiently.

The Ag9330 may be damaged by input voltage transients greater than 80V. If protection from electrostatic discharge (ESD) or other high voltage transients is required, it is recommended that over-voltage clamping devices are fitted across the VIN and AUX inputs. Typically an SMAJ58 will be sufficient; see Apps Note “ANX-POE-Protection”.

### 9 Electrical Characteristics

#### 9.1 Absolute Maximum Ratings\*

	Parameter	Symbol	Min	Max	Units
1	DC Supply Voltage	$V_{CC}$	-0.3	60	V
2	DC Supply Voltage Surge for 1ms	$V_{SURGE}$	-0.6	80	V
3	Storage Temperature	$T_S$	-40	+100	°C

\*Exceeding the above ratings may cause permanent damage to the product. Functional operation under these conditions is not implied. Maximum ratings assume free airflow.

#### 9.2 Recommended Operating Conditions

	Parameter	Symbol	Min	Typ	Max	Units
1	POE Input Supply Voltage	$V_{INPOE}$	36	48	57	V
2	AUX1 Input Supply Voltage	$V_{AUX1}$	20		40	Vac
3	AUXDC Input Supply Voltage	$V_{AUXDC}$	7		15	Vdc
4	POE Input Under Voltage Lockout	$V_{LOCK}$	30		36	V
5	Operating Temperature † 30W Continuous 24W Continuous 15W Continuous	$T_{OP}$	-40	25	45 70 85	$T_a / ^\circ C$

†See Section Operating Temperature Range

### 9.3 DC Electrical Characteristics\*

	DC Characteristic	Sym	Min	Typ <sup>1</sup>	Max	Units	Test Comments
1	Nominal Output Voltage	V <sub>OUT</sub>	11.5	12	12.5	V	
2	Peak Output Current VIN AUX1 <sup>2</sup> >= 24Vac AUX1 <sup>2</sup> > 20Vac to < 24Vac	I <sub>OUTP</sub>			2.5 2.5 2.0	A A A	
3	Continuous Output Current VIN AUX1 <sup>2</sup> >= 24Vac AUX1 <sup>2</sup> > 20Vac to < 24Vac	I <sub>OUTC</sub>			2.0 2.0 2.0	A A A	
4	Line Regulation VIN = 36V to 57V @ max load	V <sub>LINE</sub>		0.1		%	
5	Load Regulation min to max load (VIN = 50V)	V <sub>LOAD</sub>		0.1		%	
5	Output Ripple and Noise Max load <sup>3</sup>	V <sub>RN</sub>		175		mVp-p	
7	Minimum Load	R <sub>LOAD</sub>		200		mA	for specified regulation <sup>5</sup>
8	Short-Circuit Duration	T <sub>SC</sub>			∞	sec	Continuous @ 25 °C, V <sub>IN</sub> =52V
9	Efficiency VIN <sup>4</sup> = 50V AUX1 <sup>5</sup> = 24Vac AUX DC <sup>6</sup> = 12V	EFF		87 87 95		% % %	@ 50% Load
10	Isolation Voltage (I/O)	V <sub>ISO</sub>			1500	V <sub>PK</sub>	Impulse Test

1: Typical figures are at 25°C with a nominal 50V supply and are for design aid only. Not Guaranteed

2: Based on rms sine wave rectification and smoothing

3: The output ripple and noise can be reduced with an external filter, see application note.

4: Test configuration as shown in Figure 6.

5: Efficiency measured at AUX1 input pins (after external bridge rectifier) to VDC output pins.

6: Test configuration as shown in Figure 7, the efficiency can be improved by using a diode (Figure 7 - D1) that has a lower V<sub>F</sub>.

### 10 Package

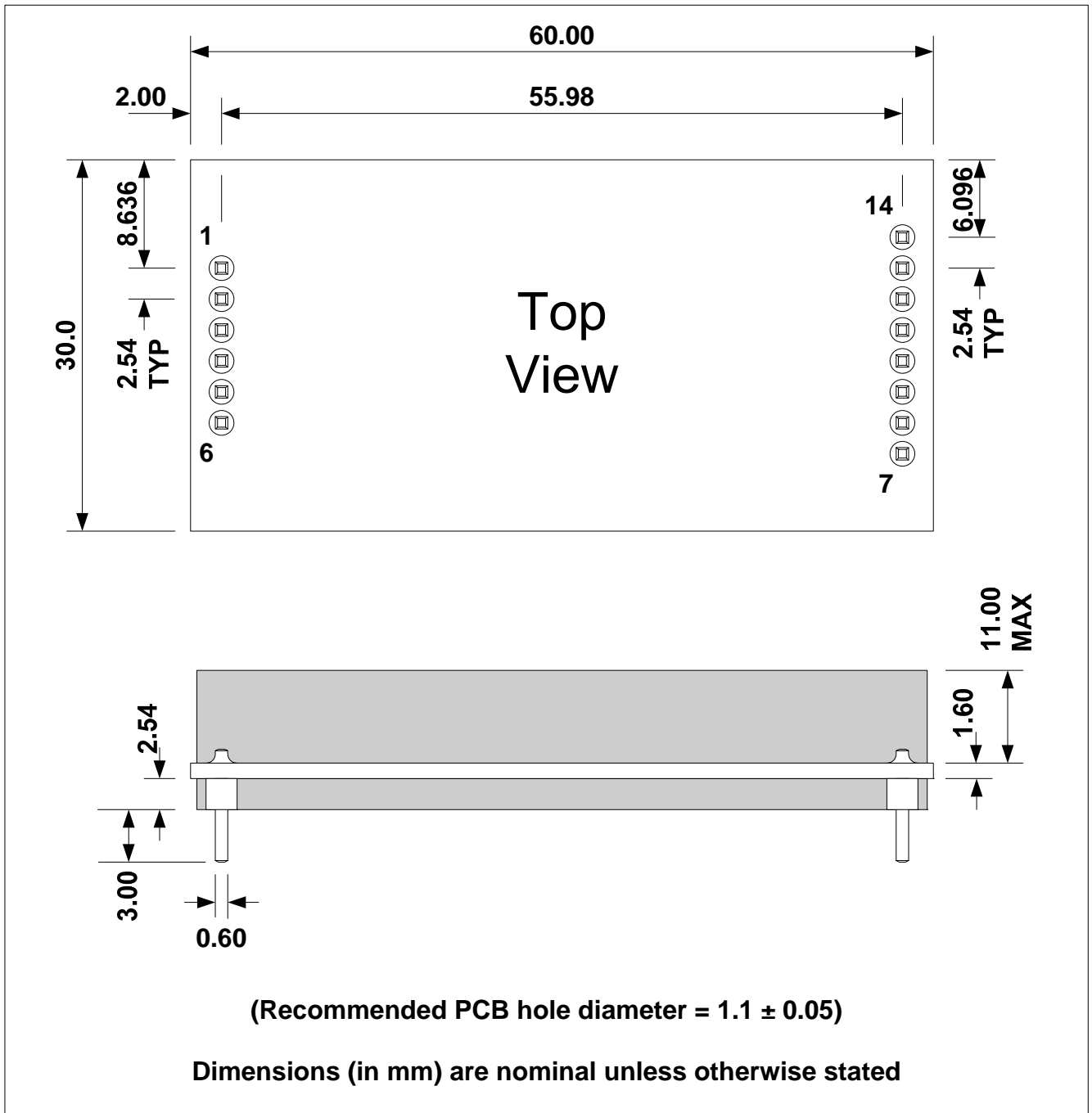

Information published in this datasheet is believed to be correct and accurate. Silver Telecom assumes no liability for errors which may occur or for liability otherwise arising out of use of this information or infringement of patents which may occur as a result of such use. No license is granted by this document under patents owned by Silver Telecom or licensed from third parties by Silver Telecom. The products, their specification and information appearing in this document are subject to change by Silver Telecom without notice.