

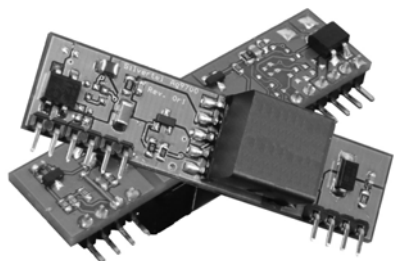

# Ag9700-I

## Power-Over-Ethernet Module



### 1. Features

- IEEE802.3af compliant
- Industrial temperature operating range -40°C to +85°C
- Small SIL package size - 56mm (L) x 14mm (H)
- Input voltage range 36V to 57V
- Minimal external components required
- Short-circuit protection
- Adjustable Output
- 1500V isolation (input to output)
- Silvertel "design-in" assistance

### 2. Description

The Ag9700-I series are an industrial temperature range of modules, designed to extract power from a conventional twisted pair Category 5 Ethernet cable, conforming to the IEEE 802.3af Power-over-Ethernet (PoE) standard.

The Ag9700-I signature and control circuit provides the PoE compatibility signature required by the Power Sourcing Equipment (PSE) before applying up to 15W power to the port. The Ag9700-I provides a Class 0 signature, classification programmable versions are available on request.

The DC/DC converter operates over a wide input voltage range and provides a regulated output. The DC/DC converter also has built-in short-circuit output protection.

## Table of Contents

1.	Features .....	1
2.	Description.....	1
	Table of Contents.....	2
	Table of Figures .....	2
3.	Ag9700-I Product Selector.....	3
4.	Pin Description .....	4
5.	Functional Description .....	5
	5.1 Inputs.....	5
	5.2 PD Signature .....	5
	5.3 Isolation .....	5
	5.4 Power Classification .....	6
	5.5 DC/DC Converter .....	6
	5.6 Output Adjustment.....	6
	5.7 Typical Connections .....	7
	5.8 Additional Output Filtering .....	8
	5.9 Start-up Power.....	8
6.	Typical Application.....	9
7.	Layout Recommendations .....	10
8.	Operating Temperature Range.....	10
9.	Protection .....	13
10.	EMC.....	13
11.	Electrical Characteristics.....	14
	11.1 Absolute Maximum Ratings <sup>1</sup> .....	14
	11.2 Recommended Operating Conditions.....	14
	11.3 DC Electrical Characteristics .....	14
12.	Package .....	15

## Table of Figures

Figure 1:	Block Diagram .....	3
Figure 2:	Ag9700-I Package Format.....	4
Figure 3:	Typical System Diagram.....	5
Figure 4:	Output Adjustment.....	6
Figure 5:	Typical Connection Diagram.....	7
Figure 6:	Output Filtering .....	8
Figure 7:	Typical Application.....	9
Figure 8:	Typical Layout.....	10
Figure 9:	Power Plane Heatsink for Ag9700-I.....	11
Figure 10:	Ag9705-2BRI Operating Profile .....	11
Figure 11:	Ag9712-2BRI Operating Profile .....	12

### 3. Ag9700-I Product Selector

Part Number†	Nominal Output Voltage	Maximum Output Power *	Marking
Ag9712-2BRI	12.0V	12 Watts	12I
Ag9705-2BRI	5.0V	9 Watts	5I

\*At 25°C with  $V_{IN} = 48V$

† The Ag9700-I fully meets the requirements of the RoHS directive 2002/95/EC on the restriction of hazardous substances in electronic equipment.

**Table 1: Ordering Information**

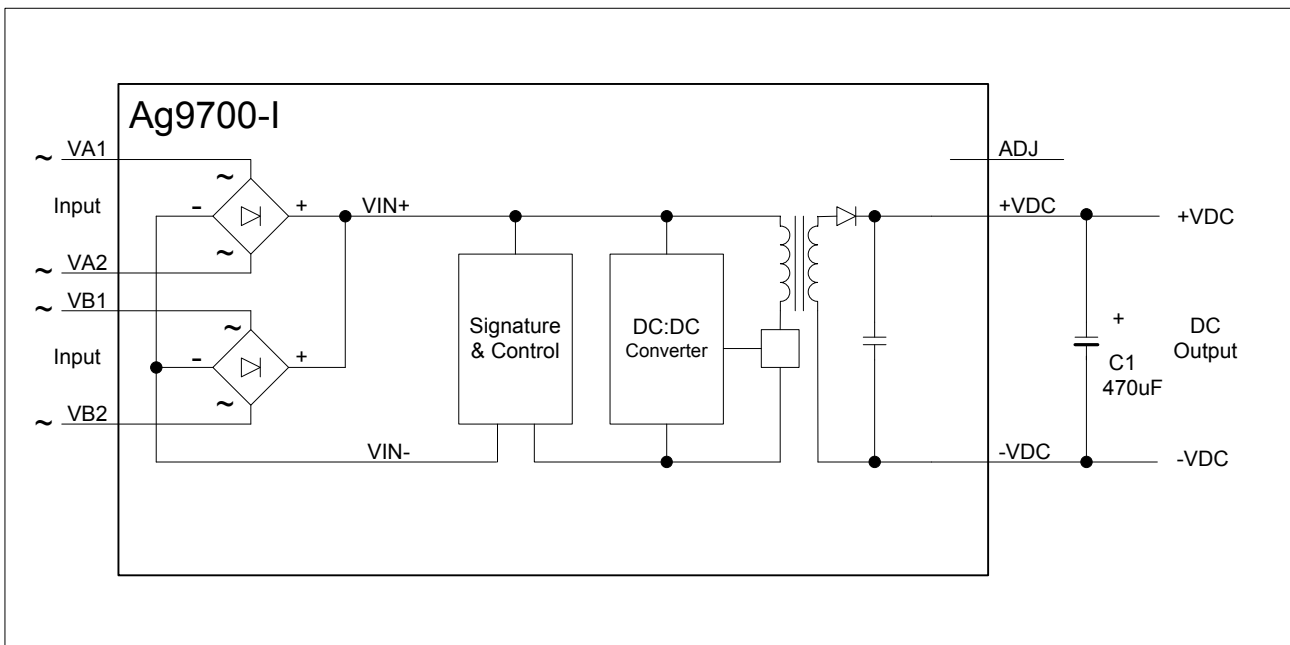

Figure 1: Block Diagram

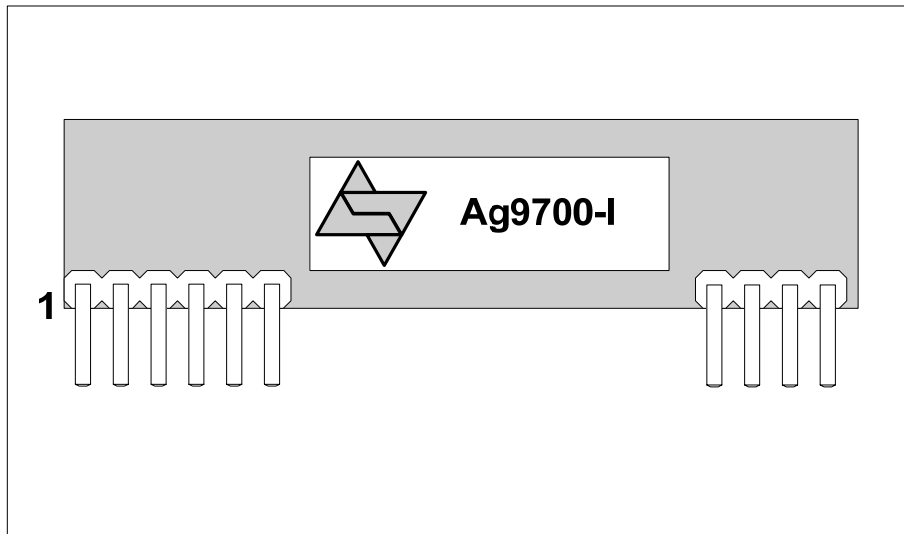

Figure 2: Ag9700-I Package Format

## 4. Pin Description

Pin #	Name	Description
1	VA1	<b>RX Input (1).</b> This input pin is used in conjunction with VA2 and connects to the centre tap of the transformer connected to pins 1 & 2 of the RJ45 connector (RX) - it is not polarity sensitive.
2	VA2	<b>TX Input (2).</b> This input pin is used in conjunction with VA1 and connects to the centre tap of the transformer connected to pins 3 & 6 of the RJ45 connector (TX) - it is not polarity sensitive.
3	VB1	<b>Direct Input (1).</b> This input pin is used in conjunction with VB2 and connects to pin 4 & 5 of the RJ45 connector - it is not polarity sensitive.
4	VB2	<b>Direct Input (2).</b> This input pin is used in conjunction with VB1 and connects to pin 7 & 8 of the RJ45 connector - it is not polarity sensitive.
5	IC	<b>Internal Connection.</b> Do not connect to this pin.
6	NC	<b>No Connection.</b>
7	-VDC	<b>DC Return.</b> This pin is the return path for the +VDC output.
8	+VDC	<b>DC Output.</b> This pin provides the regulated output from the DC/DC converter.
9	ADJ	<b>Output Adjust.</b> The output voltage can be adjusted from its nominal value, by connecting an external resistor from this pin to either the +VDC pin or the -VDC pin.
10	IC	<b>Internal Connection.</b> Do not connect to this pin.

Table 2: Pin Description

## 5. Functional Description

### 5.1 Inputs

The Ag9700-I is compatible with equipment that uses Alternative A or Alternative B options, see Figure 3: Typical System Diagram. It is specified that the PSE does not apply power to both outputs at the same time (Refer to IEEE802.3af for more information).

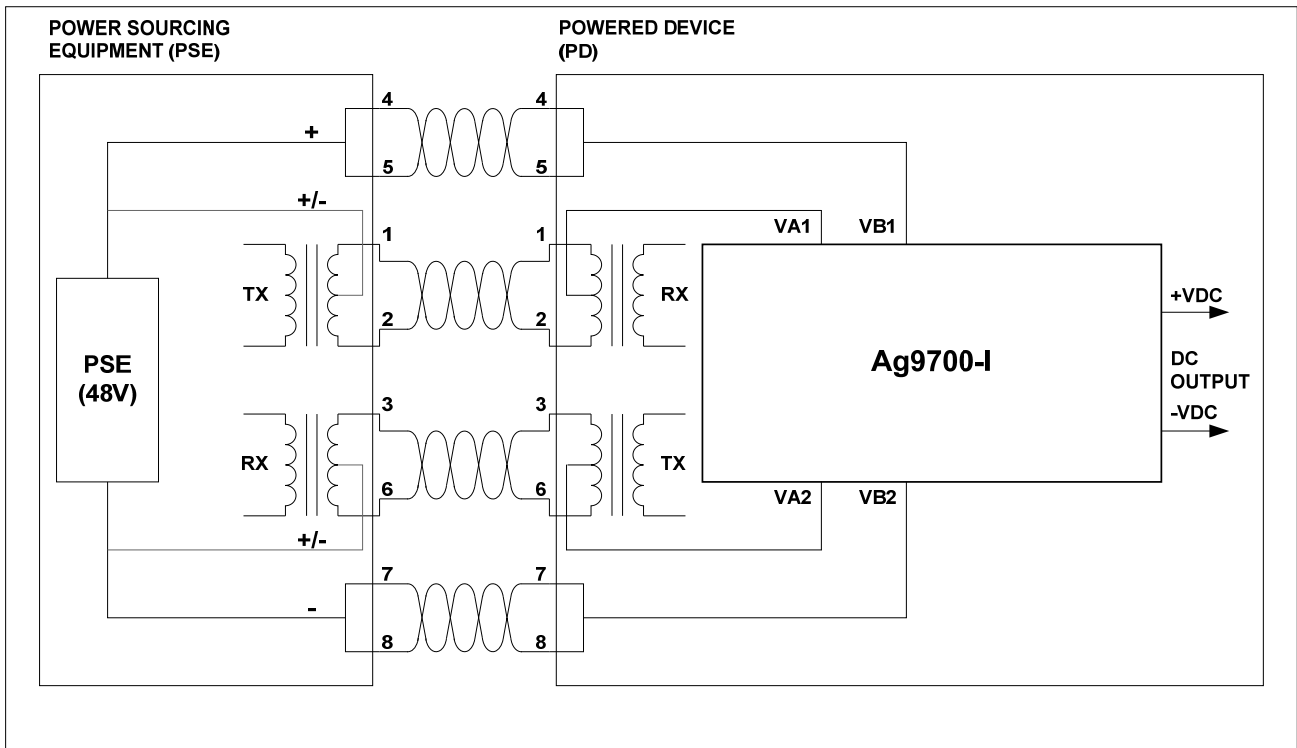

Figure 3: Typical System Diagram

### 5.2 PD Signature

When the Ag9700-I is connected to the Cat 5e cable, it will automatically present a Powered Device (PD) signature to the Power Sourcing Equipment (PSE) or Midspan Equipment, when requested. The equipment will then recognise that a powered device is connected to that line and supply power.

### 5.3 Isolation

To meet the safety isolation requirements of IEEE802.3af section 33.4.1 a Powered Device (PD) must pass the electrical strength test of IEC 60950 sub clause 6.2. This calls for either a) 1500Vac test or b) 1500V impulse test. The Ag9700-I is specified to meet the 1500Vdc impulse test. It is also important that the tracks on either side of the isolation barrier have at least a 3mm clearance, see Figures 8 & 9 and Section 12 for more information.

## 5.4 Power Classification

To minimise cost, the Ag9700-I is fixed for Class 0 (0.44 Watts to 12.95 Watts) operation, however class programmable versions are available on request. Please contact Silvertel, or your local agent for more information.

## 5.5 DC/DC Converter

The Ag9700-I's DC/DC converter provides a regulated output that has built-in short-circuit output protection – refer Table 1: Ordering information for voltage and power ratings

## 5.6 Output Adjustment

The Ag9700-I has an ADJ pin, which allows the output voltage to be increased or decreased from its nominal value. Figure 4: Output Adjustment shows how the ADJ pin is connected.

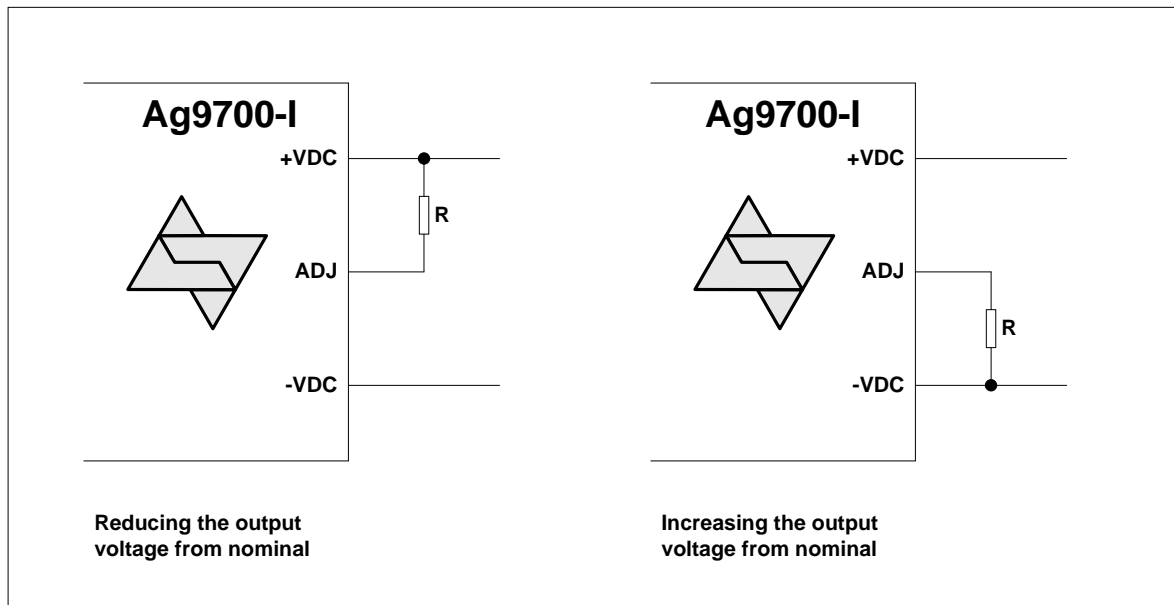

Figure 4: Output Adjustment

<b>Reducing the output voltage, connect R between ADJ and +VDC</b>			
Ag9705-2BRI		Ag9712-2BRI	
Value of R	Output	Value of R	Output
Open	5.00V	Open	12.00V
0 Ohms	4.45V	0 Ohms	10V
<b>Increasing the output voltage, connect R between ADJ and -VDC</b>			
Ag9705-2BRI		Ag9712-2BRI	
Value of R	Output	Value of R	Output
Open	5.00V	Open	12.00V
0 Ohms	5.65V	0 Ohms	12.65V

Table 3: Output Adjustment Resistor (R) Value

## 5.7 Typical Connections

The Ag9700-I requires minimal external components as shown in Figure 5: Typical Connection Diagram.

C1 must be fitted for output stability and should be a minimum of 470 $\mu$ F. This capacitor should be positioned as close to the output pins as possible. C1 is also required to handle load step change and reduce the output ripple. For applications where the output needs to cope with high load step changes, the value of C1 may need to be increased to a minimum of 1000 $\mu$ F. This can be a standard low cost electrolytic, but by using a low ESR electrolytic this would reduce the ripple. A low ESR capacitor is recommended for operation below 0°C.

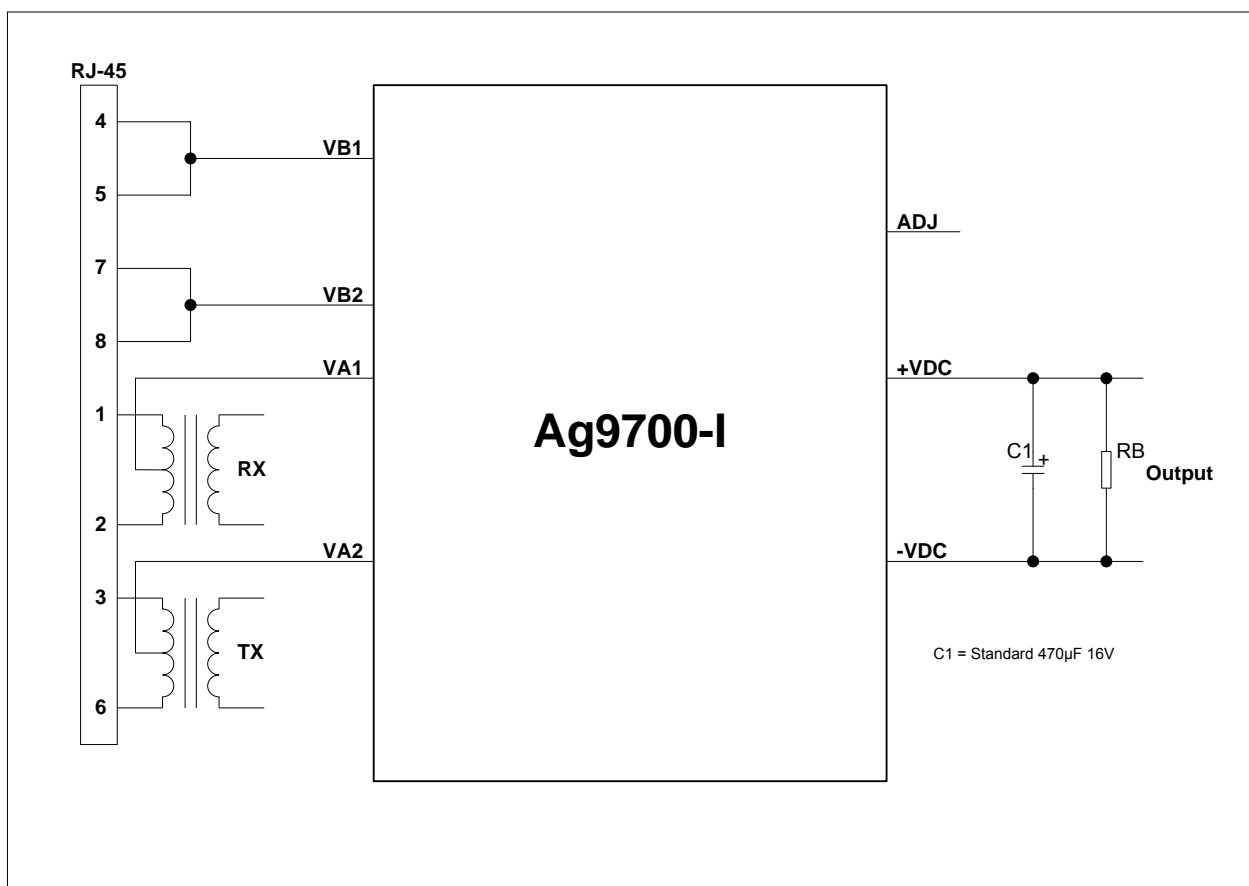

**Figure 5: Typical Connection Diagram**

The output adjust input (ADJ) is optional, it is provided to give greater flexibility to the Ag9700-I product range. Further information on using these inputs can be found in section 5.6 Output Adjustment.

The Ag9700-I must always supply a minimum current, see Table 11.3. When operated below this level the Ag9700-I will emit a low level audible noise. If this audible noise is not an issue, then it is possible for the Ag9700-I to work safely with no load at all\*. But to ensure that the PSE has a sufficient load to meet its Maintain Power Signature (MPS), it would be advisable not to operate the Ag9700-I below the specified minimum load.

\* Note: It is important that the Ag9700-I has a load connected during start-up. This is to ensure that the output voltage does not over-shoot, which can cause the on-board dc/dc converter to shut-down. Contact Silvertel for more information on using the Ag9700-I with loads below the minimum specified in Table 11.3 - DC Electrical Characteristics.

## 5.8 Additional Output Filtering

The Ag9700-I as shown in Figure 5, offers basic output filtering for ripple and noise; which at maximum load this is typically 200mVp-p (Ag9712). Figure 6 shows two cost effective methods for reducing the ripple and noise, if required.

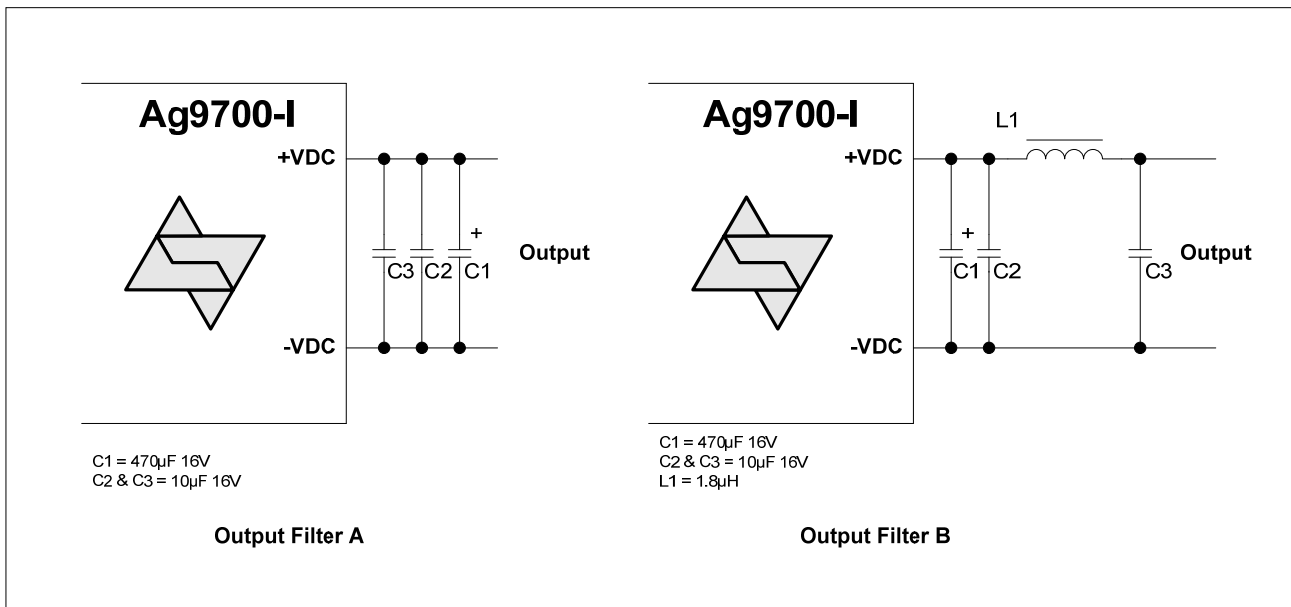

**Figure 6: Output Filtering**

The simplest and cheapest solution is shown in Figure 7 - Output Filter A. This will reduce the ripple and noise to typically 135mVp-p. Adding a PI filter, as shown in Figure 7 – Output Filter B, will take the ripple and noise level down to typically 14mVp-p. A low ESR electrolytic is recommended for operation below 0°C.

## 5.9 Start-up Power

It is important that during start-up the Ag9700-I input voltage is  $\geq 42V$ , this will ensure that the module powers up correctly. Once the dc/dc converter is up and running the module will work normally even if the input voltage is reduced to its minimum level of 36V.

When using an IEEE802.3af compliant PSE this will not be an issue, as the minimum output voltage of the PSE must be  $\geq 44V$ .



## 6. Typical Application

The Ag9700-I can be used in numerous applications. In the example shown in Figure 7: Typical Application, the data outputs from the switch are connected to the inputs of a midspan. The midspan will then add power (to the data) on each output that supports Power over Ethernet (PoE).

In this example port 1 is connected to an ethernet camera and port 2 is connected to a wireless access point, both of these devices have a built-in Ag9700-I. When the midspan is switched on (or when the device is connected), the midspan will check each output for a PoE signature. On ports 1 and 2 the Ag9700-I will identify themselves as PoE enabled devices and the midspan will supply both data and power to these peripherals.

The other ports (shown in this example) will not have a PoE signature and the midspan will only pass the data through to these peripherals. The midspan will continuously monitor each output to see if a PoE enabled device has been added or removed.

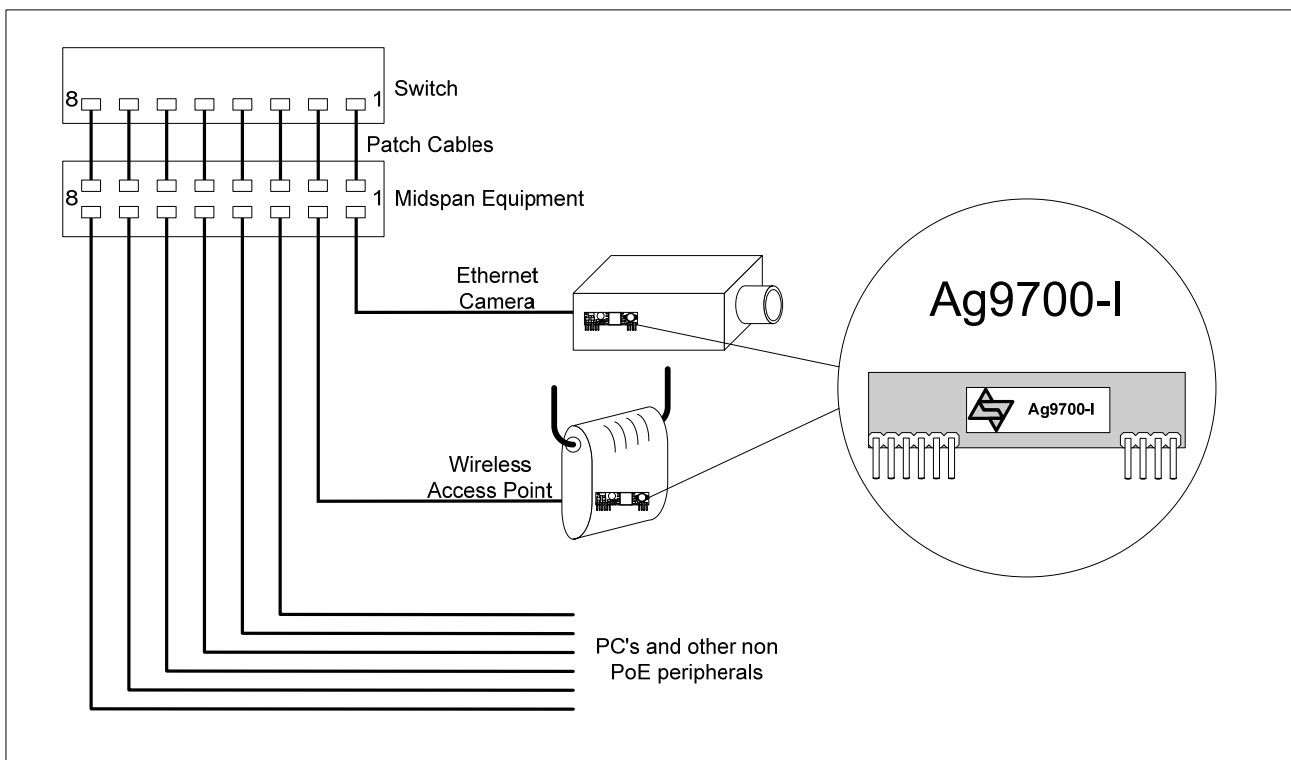

**Figure 7: Typical Application**

## 7. Layout Recommendations

Figure 8: gives an example of the tracking needed for the Ag9700-I (with Output Filter A). R1, R2, C1 and C2 are optional components, C1 must be fitted. The thermal performance of the Ag9700-I can be improved by increasing the surface area of the output tracks (+VDC and -VDC). This is not applicable if the Ag9700-I is in a socket.

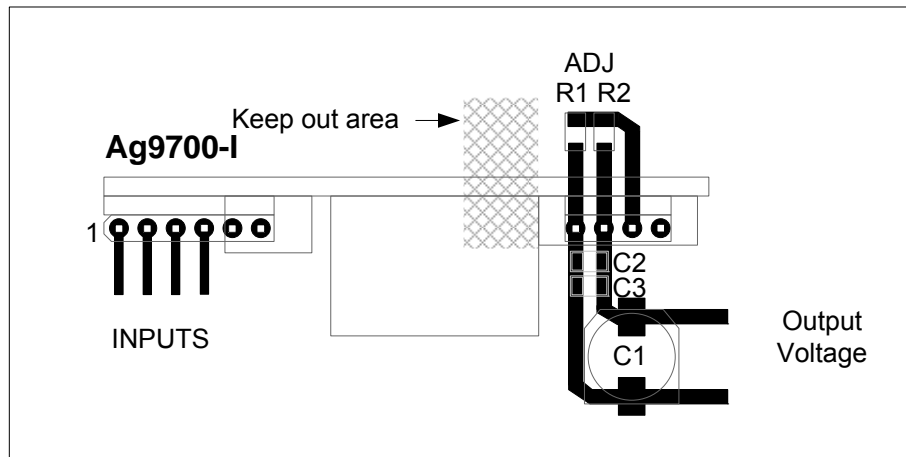

**Figure 8: Typical Layout**

## 8. Operating Temperature Range

Because the Ag9700-I is a power component, it will generate heat, so it is important that this be taken into consideration at the design stage.

The heart of the Ag9700-I is a DC/DC converter, which like any other power supply will generate heat. The amount of heat generated by the module will depend on the load it is required to drive and the input voltage supplied by the PSE. The information shown within this section of datasheet is referenced to a nominal 48Vdc input voltage supplied by the PSE.

The Ag9700-I has a maximum ambient operating temperature of 85°C see Figures 10 and 11. These results are in still air without any heatsinking. The performance of the Ag9700-I can be improved by forcing the airflow over the part or by using a heatsink (see the Ag9700-I application note on heatsinking for more information).

The output stage of the Ag9700-I has no built-in thermal protection. To prevent the module from being damaged it is recommended that the module be powered by an IEEE 802.3af compliant PSE or Midspan equipment. However the Ag9700-I may be powered by a user designed power supply which should include thermal and over current protection.

Because each application is different it is impossible to give fixed and absolute thermal recommendations. However it is important that any enclosure used has sufficient ventilation for the Ag9700-I and a direct airflow if possible.

One simple method for drawing some of the heat away from the Ag9700-I is shown in Figure 9. Power planes connected to the +VDC and -VDC pins of the Ag9700-I can be used to draw heat away from the DC/DC converter via the output pins.

These power planes must be on the outer layers of the PCB and the Ag9700-I must not be fitted into a socket.

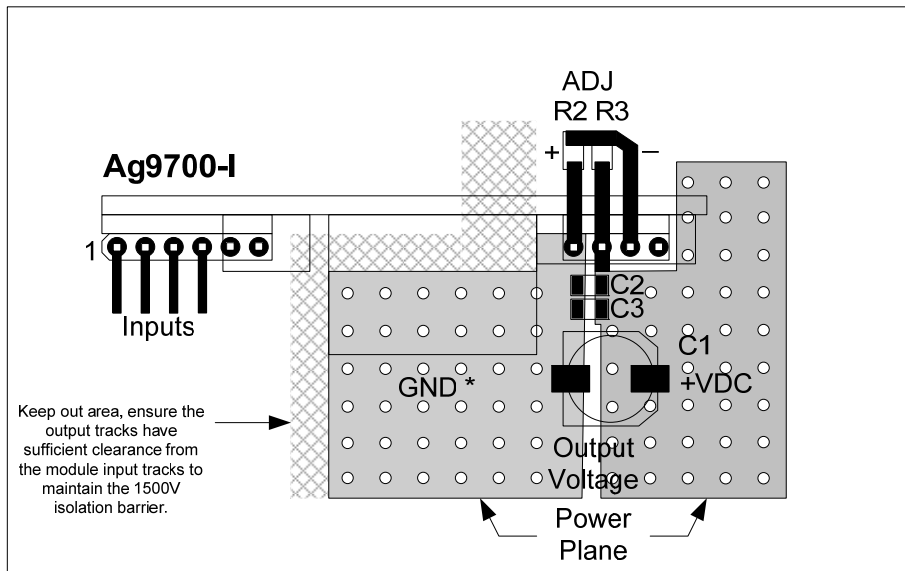

Figure 9: Power Plane Heatsink for Ag9700-I

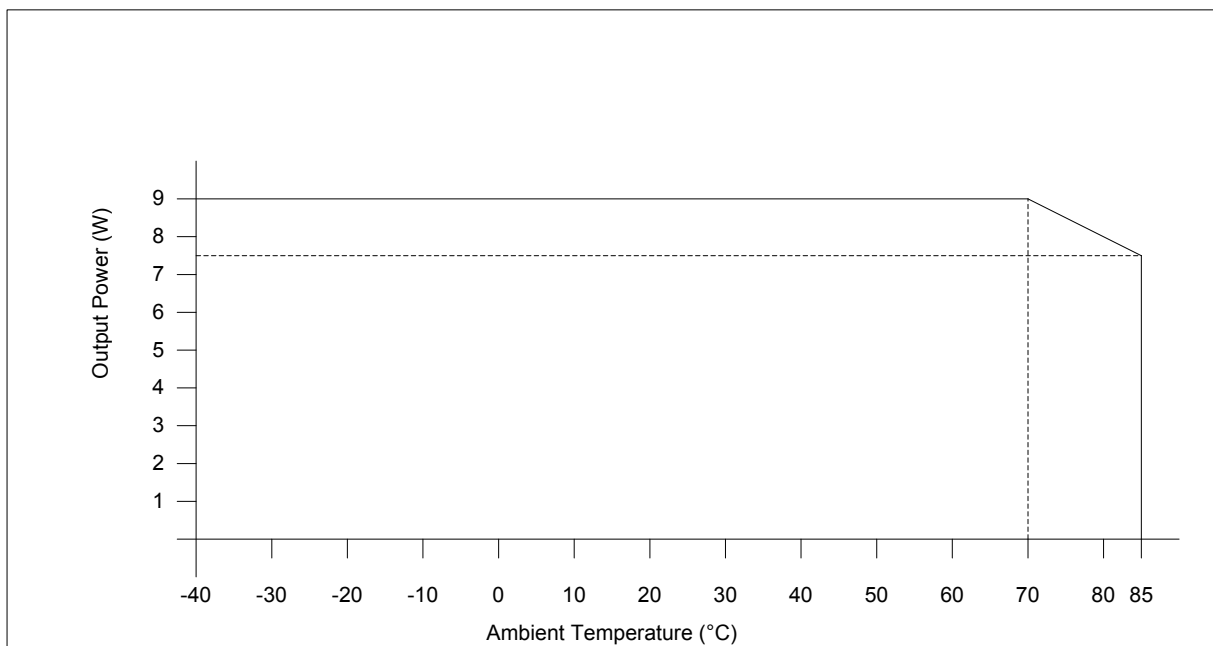

Figure 10: Ag9705-2BRI Operating Profile

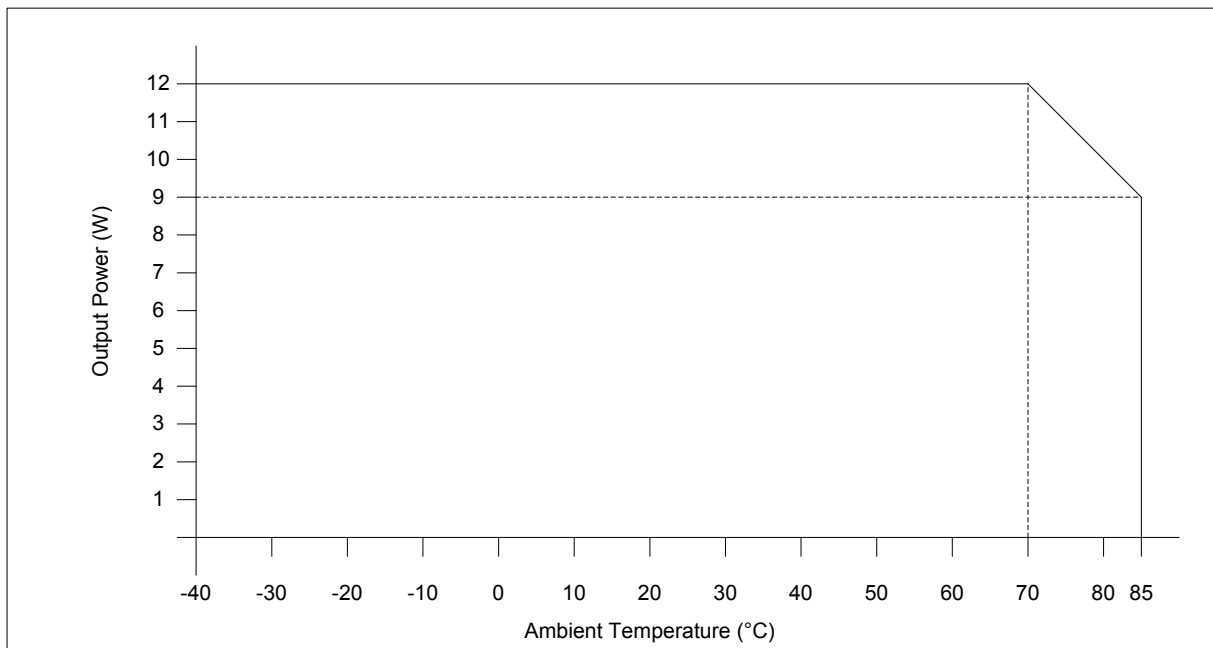

Figure 11: Ag9712-2BRI Operating Profile

It is important to remember that the ESR of the external electrolytic capacitors will increase considerably when the ambient temperature falls below 0°C. If the Ag9700-I is going to be used in applications where the ambient temperature can fall below 0°C, selection of appropriate output filter components must be done at the design stage.

## 9. Protection

The Ag9700-I must be protected from over-voltages exceeding the 80V maximum rated surge input voltage. An inexpensive but effective solution can be achieved by connecting Tranzorb diodes across each of the inputs; see Apps Note “ANX-POE-Protection”.

## 10. EMC

Because the Ag9700-I will only be one component within your system, it is impossible to say whether the final product will pass EMC testing, without the need for additional filtering. The Ag9700-I uses a DC:DC converter with pulse frequency modulation, so care does need to be taken to minimise emissions. To help with this an Apps Note “ANX-POE-EMI” has been written with tips and suggestions.

## 11. Electrical Characteristics

### 11.1 Absolute Maximum Ratings<sup>1</sup>

	Parameter	Symbol	Min	Max	Units
1	DC Supply Voltage	$V_{CC}$	-0.3	60	V
2	DC Supply Voltage Surge for 1ms	$V_{SURGE}$	-0.6	80	V
3	Storage Temperature	$T_S$	-50	+100	°C

Note 1: Exceeding the above ratings may cause permanent damage to the product. Functional operation under these conditions is not implied. Maximum ratings assume free airflow.

### 11.2 Recommended Operating Conditions

	Parameter	Symbol	Min	Typ	Max	Units
1	Input Supply Voltage <sup>1</sup>	$V_{IN}$	36	48	57	V
2	Under Voltage Lockout	$V_{LOCK}$	30		36	V
3	Operating Temperature <sup>2</sup>	$T_{OP}$	-40	25	85	Ta / °C

Note 1: With minimum load

2: See Section Operating Temperature Range

### 11.3 DC Electrical Characteristics

	DC Characteristic	Sym	Min	Typ <sup>1</sup>	Max	Units	Test Comments
1	Nominal Output Voltage	+VDC	4.75 11.5	5.0 12.0	5.25 12.5	V V	Ag9705-2BRI Ag9712-2BRI
2	Output Current ( $V_{IN} = 48V$ )	PWR			1.8 1.0	A A	Ag9705-2BRI Ag9712-2BRI
3	Line Regulation	$V_{LINE}$		0.05		%	
4	Load Regulation - Min to Max ( $V_{IN} = 48V$ )	$V_{LOAD}$		0.5 0.12		% %	Ag9705-2BRI Ag9712-2BRI
5	Output Ripple and Noise	$V_{RN}$		200		mVp-p	@ Max load <sup>2</sup>
6	Minimum Load <sup>3</sup>	$I_{LOAD}$	200 100			mA mA	Ag9705-2BRI Ag9712-2BRI
7	Short-Circuit Duration	$T_{SC}$			∞	sec	
8	Efficiency @ 80% Load	EFF		80 84		% %	Ag9705-2BRI Ag9712-2BRI
9	Isolation Voltage (I/O)	$V_{ISO}$			1500	$V_{PK}$	Impulse Test

Note 1: Typical figures are at 25°C with a nominal 48V supply and are for design aid only. Not Guaranteed

2: The output ripple and noise can be reduced with an external filter, see Section 5.8.

3: The module can emit an audible noise, if operated at less than the specified minimum  $I_{LOAD}$  and cause the PSE to fail its MPS, contact Silvertel for more information.

## 12. Package

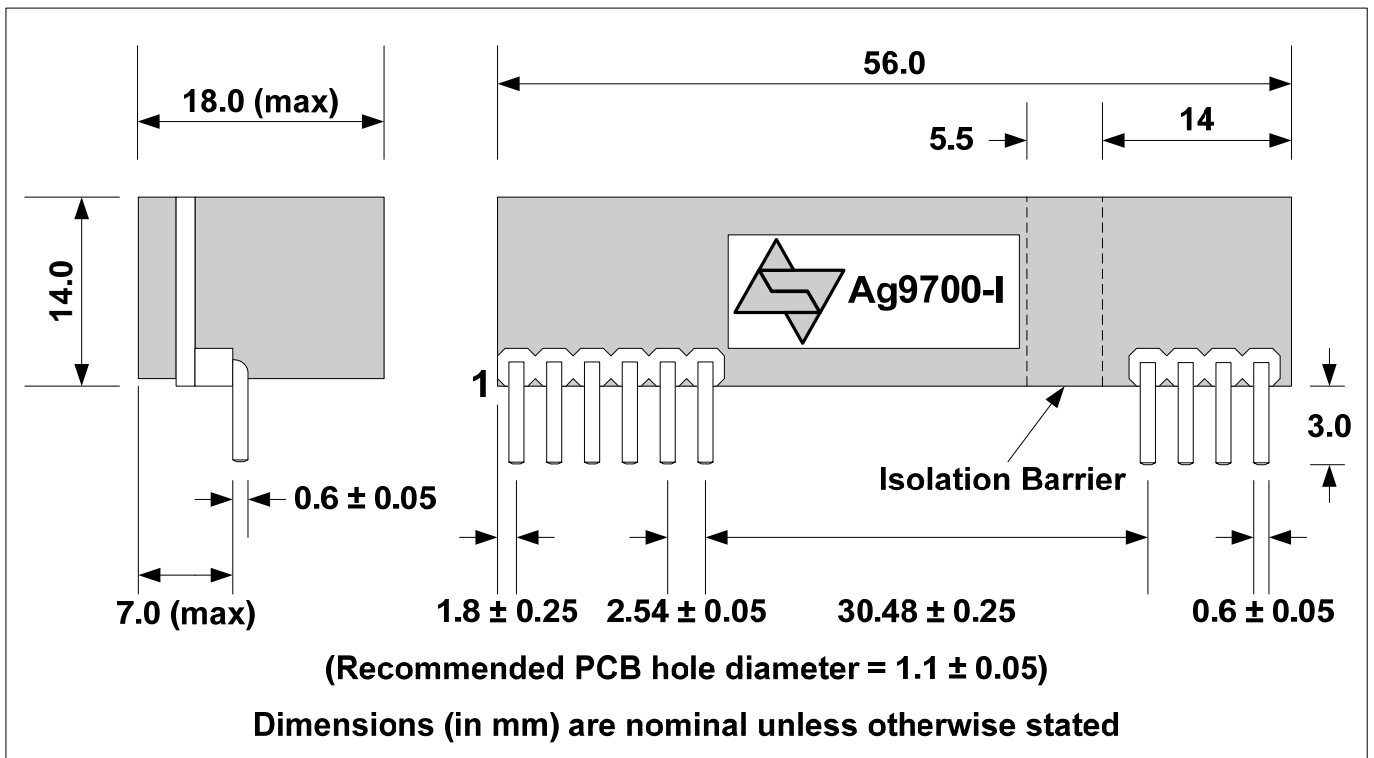

Information published in this datasheet is believed to be correct and accurate. Silver Telecom assumes no liability for errors which may occur or for liability otherwise arising out of use of this information or infringement of patents which may occur as a result of such use. No license is granted by this document under patents owned by Silver Telecom or licensed from third parties by Silver Telecom. The products, their specification and information appearing in this document are subject to change by Silver Telecom without notice.