

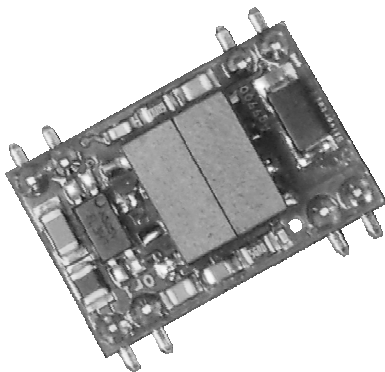

# Ag9912M

## Ultra Miniature PoE Module



### 1. Features

- Tiny SMT package (14mm x 21mm)
- IEEE802.3af compliant
- Low cost
- Input voltage range 36V to 57V
- Minimal external components required
- Short-circuit protection
- Adjustable Output
- 1500V isolation (input to output)
- Silvertel "design-in" assistance

### 2. Description

The Ag9912M Power-over-Ethernet (PoE) module is the smallest POE solution in the world and designed to extract power from a conventional twisted pair Category 5 Ethernet cable, conforming to the IEEE 802.3af PoE standard.

The Ag9912M signature and control circuit provides the PoE compatibility signature required by the Power Sourcing Equipment (PSE) before applying up to 15W power to the port. The Ag9912M provides a Class 0 signature.

The DC/DC converter operates over a wide input voltage range and provides a regulated output. The DC/DC converter also has built-in short-circuit output protection.

## Table of Contents

1. Features .....	1
2. Description.....	1
Table of Contents .....	2
Table of Figures .....	2
3. Ag9912M Product Selector .....	3
4. Pin Description .....	4
4.1 Ag9912M .....	5
5. Functional Description .....	6
5.1 Inputs.....	6
5.2 PD Signature .....	6
5.3 Isolation .....	6
5.4 Power Classification .....	7
5.5 DC/DC Converter .....	7
5.6 Output Adjustment.....	7
5.7 Typical Connections .....	8
5.8 Additional Output Filtering .....	9
5.9 Start-up Power.....	10
6. Typical Application.....	10
7. Operating Temperature Range.....	11
8. Layout Consideration.....	13
9. Protection .....	13
10. EMC .....	14
11. Electrical Characteristics.....	15
11.1 Absolute Maximum Ratings <sup>1</sup> .....	15
11.2 Recommended Operating Conditions.....	15
11.3 DC Electrical Characteristics .....	15
12. Package .....	16

## Table of Figures

Figure 1: Block Diagram .....	3
Figure 2: Ag9912M SMT Package Format.....	4
Figure 3: Typical System Diagram.....	6
Figure 4: Output Adjustment.....	7
Figure 5: Typical Connection Diagram.....	8
Figure 6: Output Filtering .....	9
Figure 7: Typical Application.....	10
Figure 8: Ag9912M Operating Profile .....	11
Figure 9: Ag9912M Thermal Relief.....	12
Figure 10: Layout Consideration.....	13
Figure 11: Ag9912M Input Protection .....	13

### 3. Ag9912M Product Selector

Part Number†	Nominal Output Voltage	Maximum Output Power *	Marking
Ag9912M	12.0V	12 Watts	12

\*At 25°C with  $V_{IN} = 48V$

† The Ag9912M fully meets the requirements of the RoHS directive 2011/65/EC on the restriction of hazardous substances in electronic equipment.

**Table 1: Ordering Information**

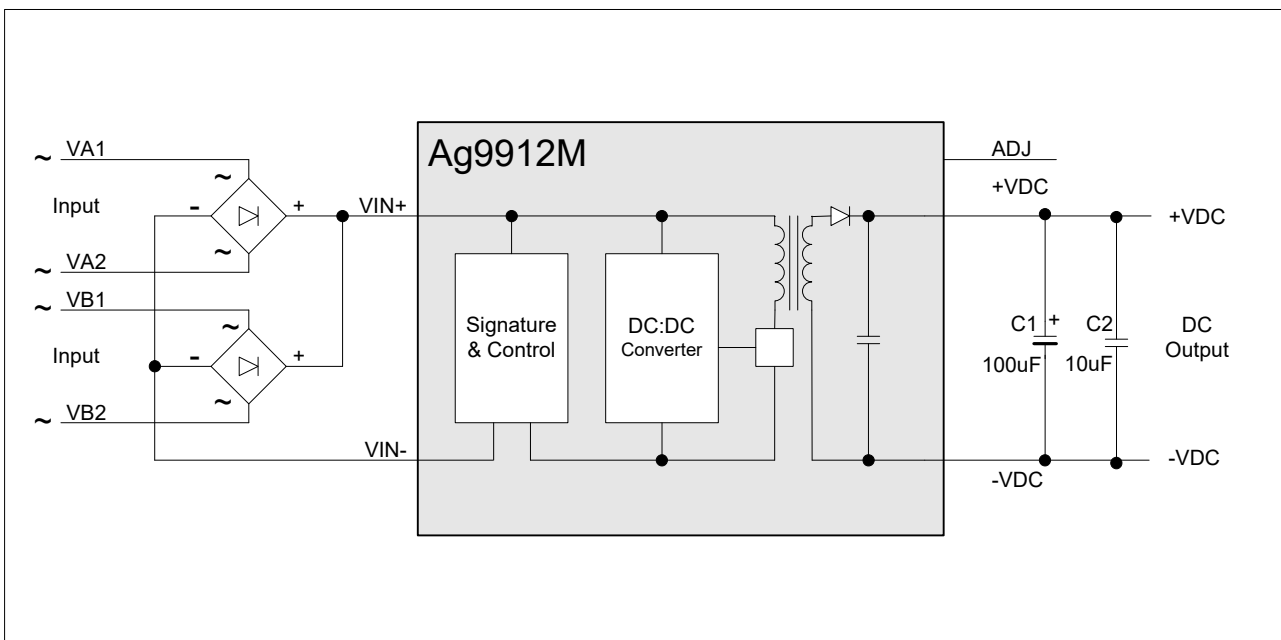

Figure 1: Block Diagram

## 4. Pin Description

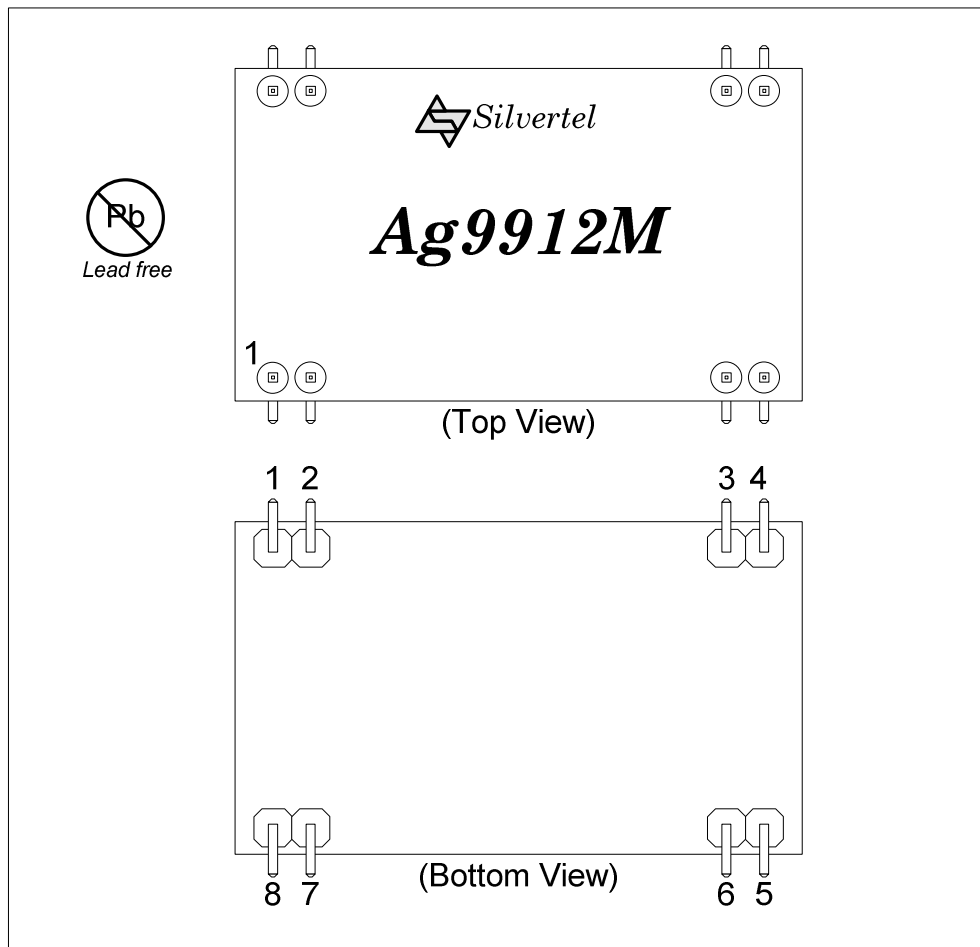

Figure 2: Ag9912M SMT Package Format

## 4.1 Ag9912M

Pin #	Name	Description
1	+VDC	<b>DC Output.</b> This pin provides the regulated output from the DC/DC converter.
2		
3	-VDC	<b>DC Return.</b> This pin is the return path for the +VDC output.
4	ADJ	<b>Output Adjust.</b> The output voltage can be adjusted from its nominal value, by connecting an external resistor from this pin to either the +VDC pin or the -VDC pin.
5	VIN+	<b>Direct Input +.</b> This pin connects to the positive (+) output of the input bridge rectifiers.
6		
7	VIN-	<b>Direct Input -.</b> This pin connects to the negative (-) output of the input bridge rectifiers.
8		

**Table 2: Pin Description**

## 5. Functional Description

### 5.1 Inputs

The Ag9912M is compatible with equipment that uses Alternative A (power on data pair) or Alternative B (power on spare pair) options, see Figure 3. It is specified that the PSE does not apply power to both outputs at the same time (Refer to IEEE802.3af for more information).

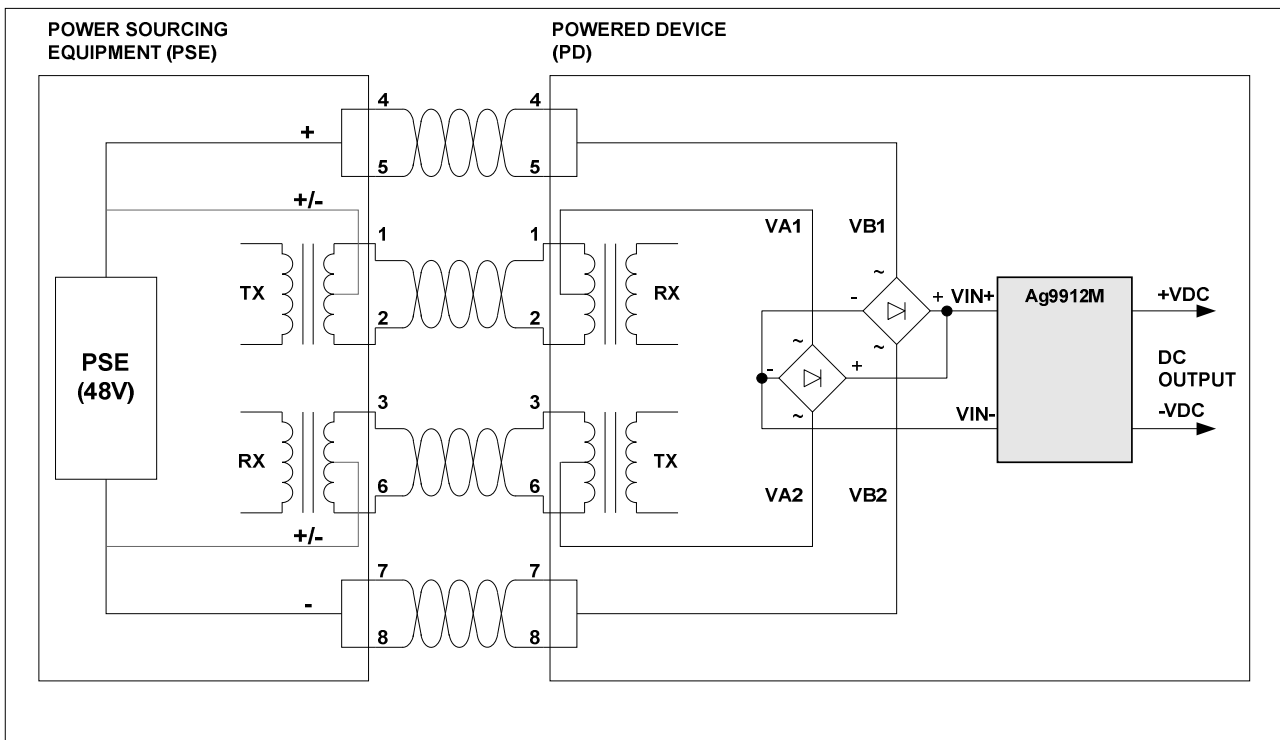

Figure 3: Typical System Diagram

### 5.2 PD Signature

When the Ag9912M is connected to the Cat5e cable, it will automatically present a Powered Device (PD) signature to the Power Sourcing Equipment (PSE) or Midspan Equipment, when requested. The equipment will then recognise that a powered device is connected to that line and supply power.

### 5.3 Isolation

To meet the safety isolation requirements of IEEE802.3af section 33.4.1 a Powered Device (PD) must pass the electrical strength test of IEC 60950 sub clause 6.2. This calls for either a) 1500Vac test or b) 1500Vdc impulse test. The Ag9912M is specified to meet the 1500Vdc impulse test. It is also important that the tracks on either side of the isolation barrier have at least a 3mm clearance, see Figures 9 & 10 for more information.

## 5.4 Power Classification

The Ag9912M is set to Class 0 (0.44 Watts to 12.95 Watts) operation.

## 5.5 DC/DC Converter

The Ag9912M's DC/DC converter provides a regulated output that has built-in short-circuit output protection – refer Table 1: Ordering information for voltage and power ratings.

## 5.6 Output Adjustment

The Ag9912M has an ADJ pin, which allows the output voltage to be increased or decreased from its nominal value. Figure 4: Output Adjustment shows how the ADJ pin is connected.

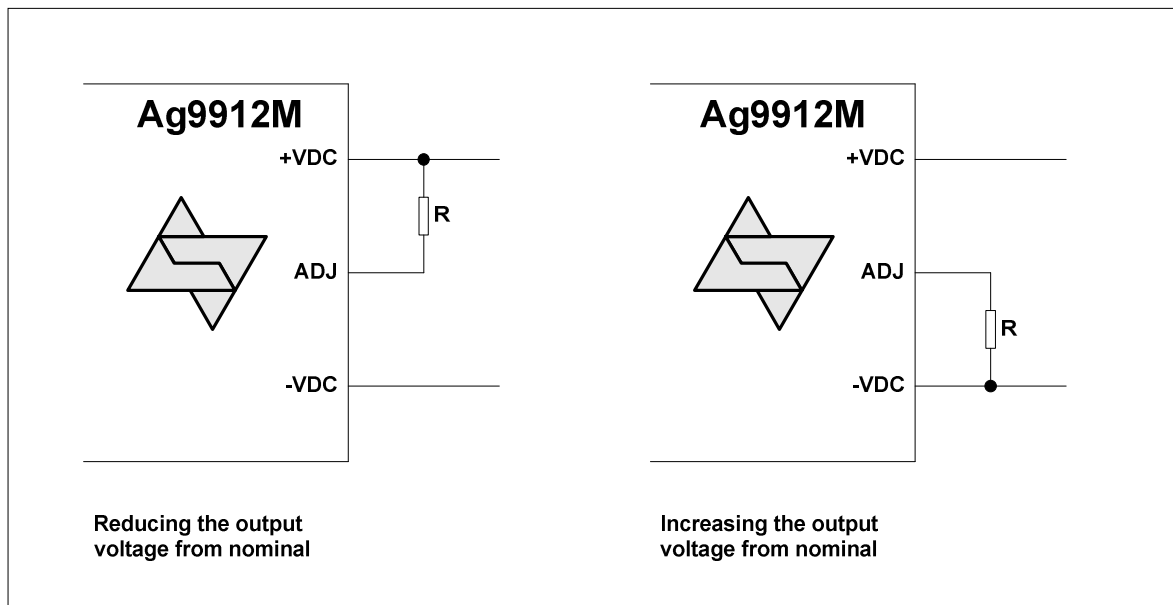

Figure 4: Output Adjustment

<b>Reducing the output voltage, connect R between ADJ and +VDC</b>	
Value of R	Output
Open	12.00V
0 Ohms	10V
<b>Increasing the output voltage, connect R between ADJ and -VDC</b>	
Value of R	Output
Open	12.00V
0 Ohms	12.75V

**Table 3: Output Adjustment Resistor (R) Value**

### 5.7 Typical Connections

The Ag9912M requires minimal external components as shown in Figure 5: Typical Connection Diagram.

C1 must be fitted for output stability and should be a minimum of 100µF. This capacitor should be positioned as close to the output pins as possible. C1 is also required to handle load step change and reduce the output ripple. For applications where the output needs to cope with high load step changes, or to reduce the output ripple we recommend using a low ESR electrolytic as this reduces the output ripple. Also a low ESR capacitor is essential for operation below 0°C.

BR1 and BR2 can be inexpensive bridge rectifiers, for example MB4S or MB6S.

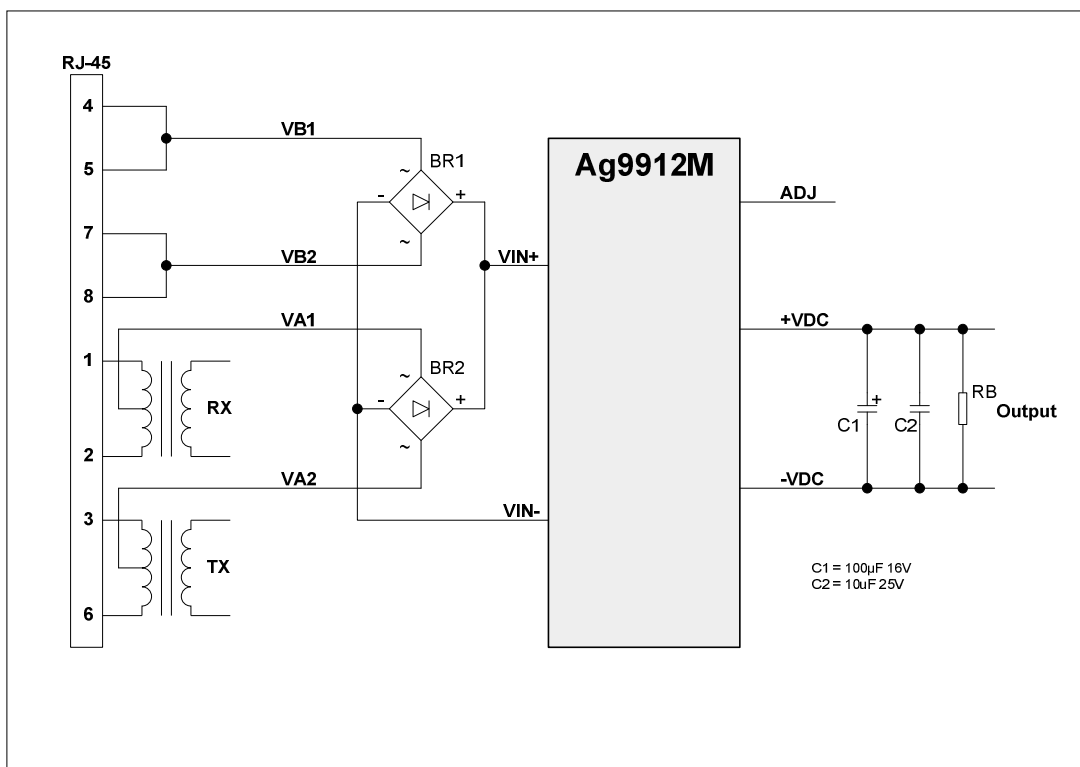

**Figure 5: Typical Connection Diagram**



The output adjust input (ADJ) is optional, it is provided to give greater flexibility to the Ag9912M product range. Further information on using these inputs can be found in Section 5.6.

The Ag9912M must always supply a minimum current, see Table 11.3. When operated below this level the Ag9912M will emit a low level audible noise. The reason that the module emits this noise is due to the dc/dc converter running in discontinuous mode.

If this audible noise is not an issue, then the Ag9912M can work safely with a much smaller load. But to ensure that the PSE has a sufficient load to meet its Maintain Power Signature (MPS), it would be advisable not to operate the Ag9912M below the specified minimum load.

## 5.8 Additional Output Filtering

The Ag9912M as shown in Figure 5 offers the minimal capacitance the customer must fit, however Figure 6 shows two cost effective methods for reducing the ripple and noise, if required.

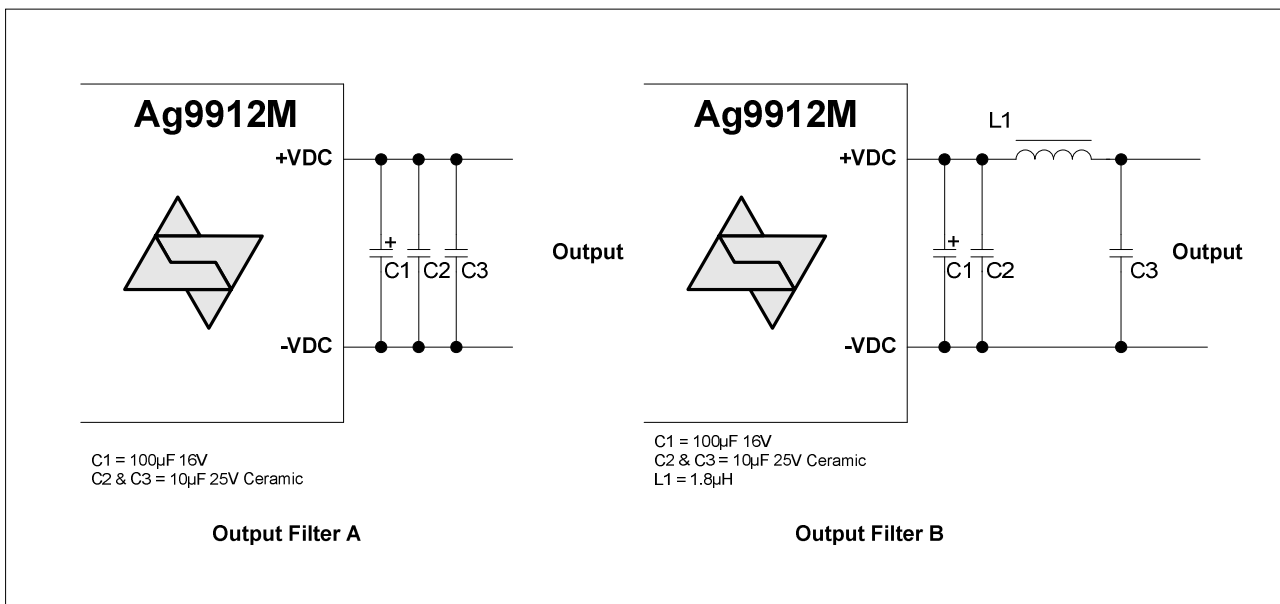

**Figure 6: Output Filtering**

The simplest and cheapest solution is shown in Figure 6 - Output Filter A. This will reduce the ripple and noise to typically 145mVp-p at maximum load. Adding a PI filter, as shown in Figure 6 – Output Filter B, will take the ripple and noise level down to typically 16mVp-p.

## 5.9 Start-up Power

It is important that during start-up the Ag9912M input voltage is  $\geq 42V$ , this will ensure that the module powers up correctly. Once the dc/dc converter is up and running the module will work normally even if the input voltage is reduced to its minimum level of 36V.

When using an IEEE802.3af compliant PSE this will not be an issue, as the minimum output voltage of the PSE must be  $\geq 44V$ .

## 6. Typical Application

The Ag9912M can be used in numerous applications. In the example shown in Figure 7, the data outputs from the switch are connected to the inputs of a midspan. The midspan will then add power (to the data) on each output that supports Power over Ethernet (PoE).

In this example port 1 is connected to an Ethernet camera and port 2 is connected to a wireless access point, both of these devices have a built-in Ag9912M. When the midspan is switched on (or when the device is connected), the midspan will check each output for a PoE signature. On ports 1 and 2 the Ag9912M will identify themselves as PoE enabled devices and the midspan will supply both data and power to these peripherals.

The other ports (shown in this example) will not have a PoE signature and the midspan will only pass the data through to these peripherals. The midspan will continuously monitor each output to see if a PoE enabled device has been added or removed.

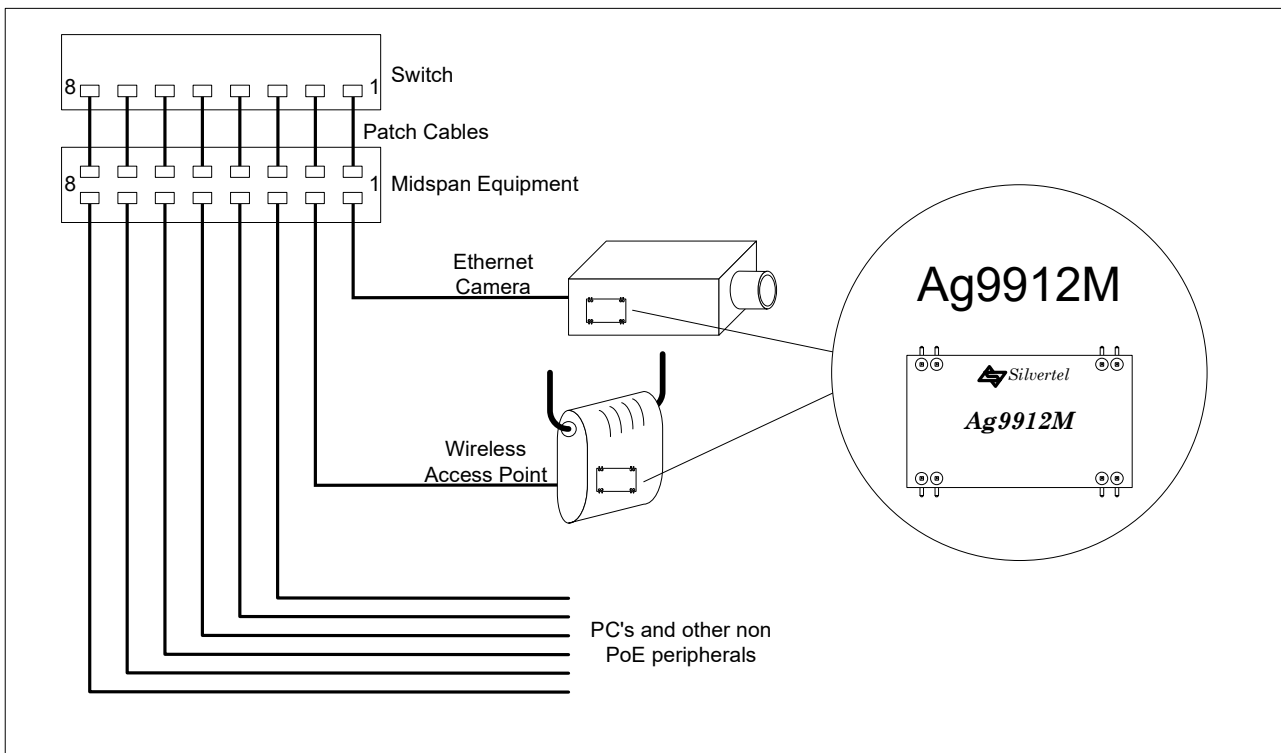

**Figure 7: Typical Application**

## 7. Operating Temperature Range

Because the Ag9912M is a power component, it will generate heat, so it is important that this be taken into consideration at the design stage.

The heart of the Ag9912M is a DC/DC converter, which like any other power supply will generate heat. The amount of heat generated by the module will depend on the load it is required to drive and the input voltage supplied by the PSE. The information shown within this section of datasheet is referenced to a nominal 48Vdc input voltage supplied by the PSE.

The Ag9912M has a maximum ambient operating temperature of 70°C see Figure 8. These results were performed in an environment chamber - Associated Environmental System SD-302, without any heat-sinking. The performance of the Ag9912M can be improved by forcing the airflow directly over the part or by using thermal relief pads (see Figure 9 and application note on thermal considerations for more information).

The output stage of the Ag9912M has no built-in thermal protection. To prevent the module from being damaged it is recommended that the module be powered by an IEEE 802.3af compliant PSE or Midspan equipment. However the Ag9912M may be powered by a user designed power supply which should include thermal and over current protection and be current limited to 400mA.

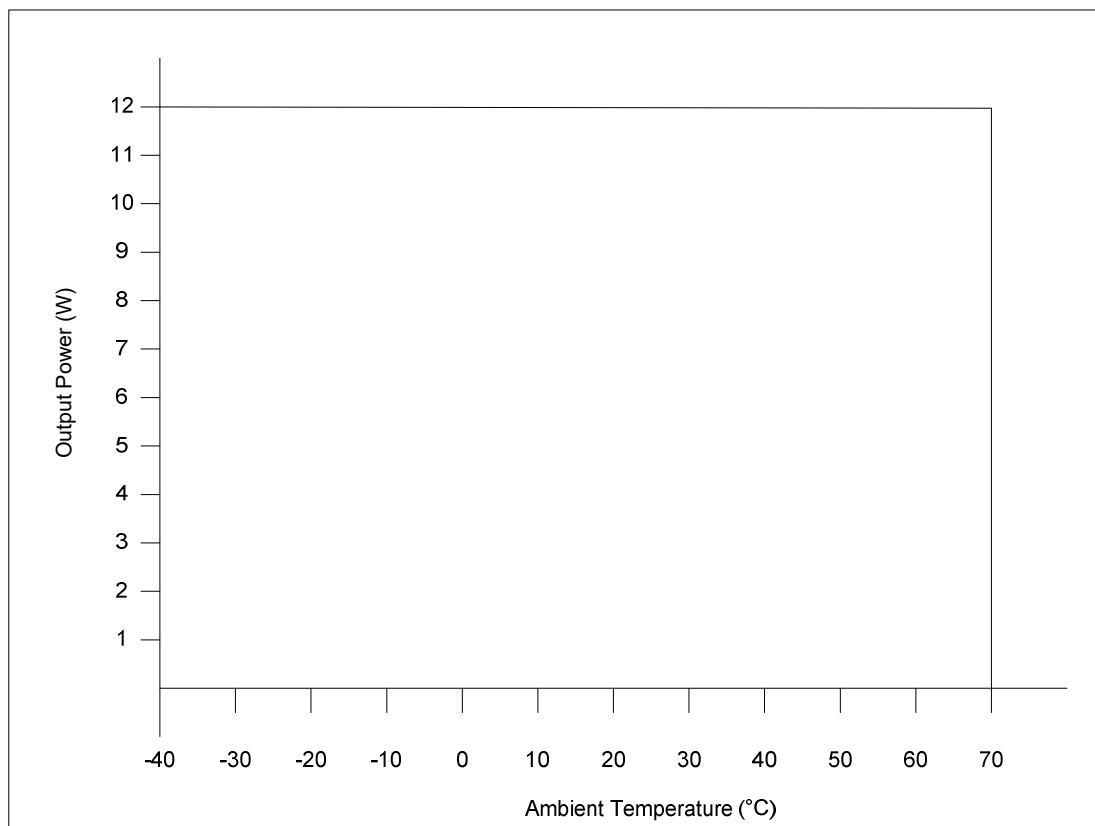

Figure 8: Ag9912M Operating Profile

Because each application is different, it is impossible to give fixed and absolute thermal recommendations. But due to the small size of this module, it is important that as much heat as possible is drawn away from it. It is also important that any enclosure used has sufficient ventilation for the Ag9912M and a direct airflow if possible.

One simple method for drawing some of the heat away from the Ag9912M is shown in Figure 9. Power planes connected to the +VDC and -VDC pins of the Ag9912M can be used to draw heat away from the DC/DC converter via the output pins.

These power planes must be on the outer layers of the PCB and the best results are achieved by having power planes on both sides of the main board with multiple through-hole connections (as shown in Figure 9).

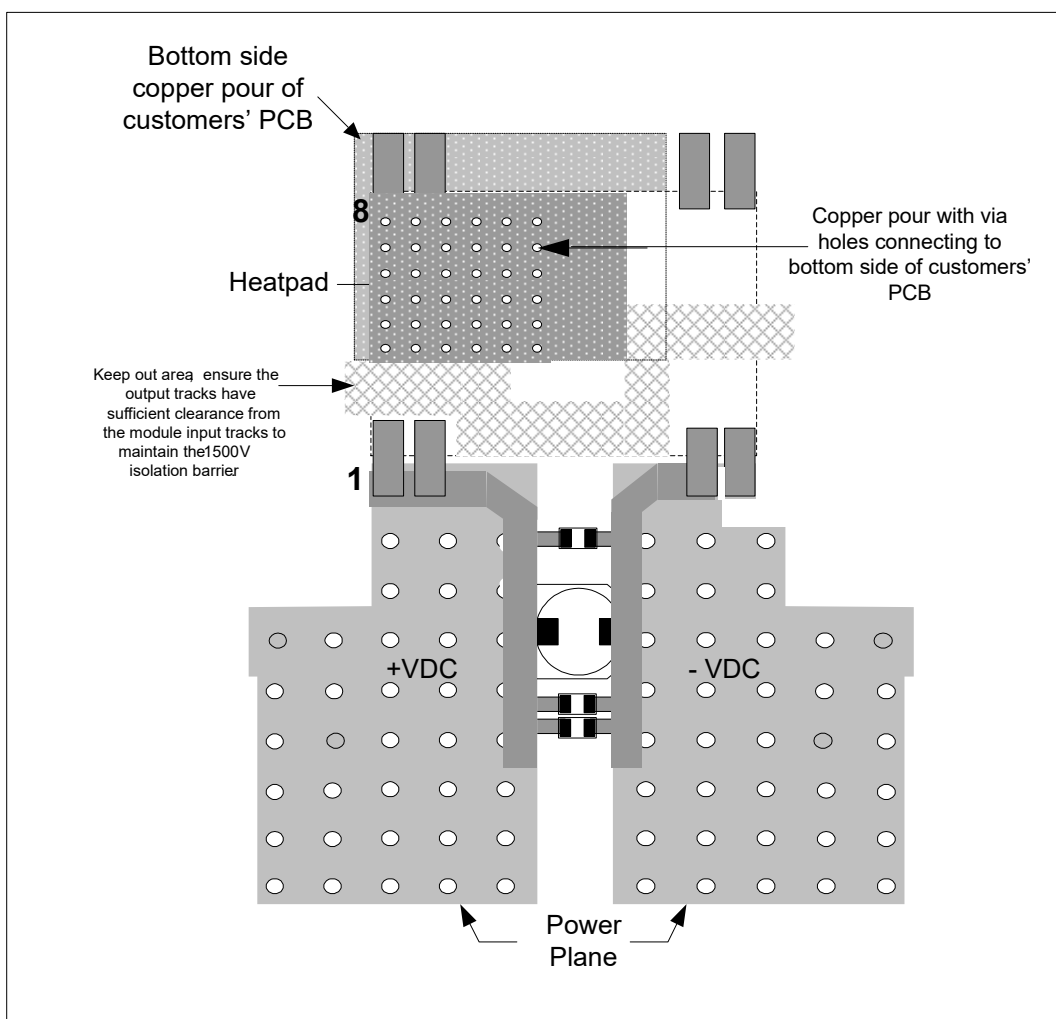
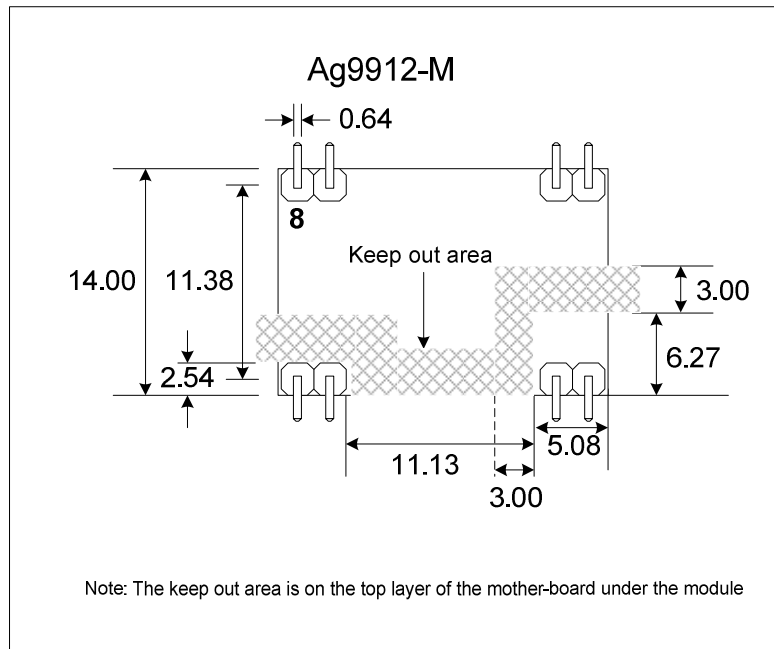

Figure 9: Ag9912M Thermal Relief

It is important to remember that the ESR of the external electrolytic capacitors will increase considerably when the ambient temperature falls below 0°C. If the Ag9912M is going to be used in applications where the ambient temperature can fall below 0°C, selection of appropriate output filter components must be done at the design stage.

## 8. Layout Consideration

Figure 10 shows the position of the isolation barrier, this area must be kept clear of tracks under the Ag9912-M module.



**Figure 10: Layout Consideration**

## 9. Protection

The Ag9912M must be protected from over-voltages exceeding the 80V maximum rated surge input voltage. An inexpensive but effective solution can be achieved by connecting a Transorb diode across the input; see Figure 11.

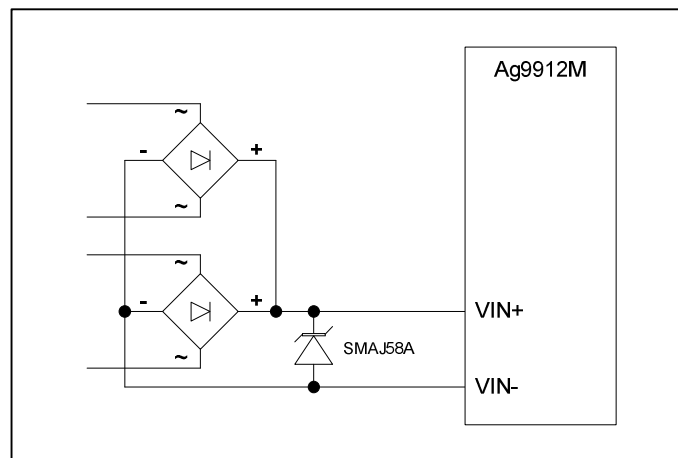

**Figure 11: Ag9912M Input Protection**

More information is available is Apps Note "ANX-POE-Protection".

## 10. EMC

The Ag9912M is designed to meet EN55022 Class B (pre-compliance test results are available from Silvertel).

However, because the Ag9912M will only be one component within your system, it is impossible to say whether the final product will pass EMC testing, without the need for additional filtering. The Ag9912M uses a dc/dc converter with pulse frequency modulation, so care does need to be taken to minimise emissions.

To help with this an Apps Note “ANX-POE-EMI” has been written with tips and suggestions.

## 11. Electrical Characteristics

### 11.1 Absolute Maximum Ratings<sup>1</sup>

	Parameter	Symbol	Min	Max	Units
1	DC Supply Voltage	$V_{CC}$	-0.3	60	V
2	DC Supply Voltage Surge for 1ms	$V_{SURGE}$	-0.6	80	V
3	Storage Temperature	$T_S$	-40	+100	°C

Note 1: Exceeding the above ratings may cause permanent damage to the product. Functional operation under these conditions is not implied. Maximum ratings assume free airflow.

### 11.2 Recommended Operating Conditions

	Parameter	Symbol	Min	Typ	Max	Units
1	Input Supply Voltage <sup>1</sup>	$V_{IN}$	36	48	57	V
2	Under Voltage Lockout	$V_{LOCK}$	30		36	V
3	Operating Temperature <sup>2</sup>	$T_{OP}$	-40	25	70	Ta / °C

Note 1: With minimum load

2: See Section Operating Temperature Range

### 11.3 DC Electrical Characteristics

	DC Characteristic	Sym	Min	Typ <sup>1</sup>	Max	Units	Test Comments
1	Nominal Output Voltage	+VDC	11.5	12.0	12.5	V	
2	Output Current ( $V_{IN} = 48V$ )	PWR			1.0	A	
3	Line Regulation	$V_{LINE}$		0.02		%	
4	Load Regulation - Min to Max ( $V_{IN} = 48V$ )	$V_{LOAD}$		0.1		%	
5	Output Ripple and Noise	$V_{RN}$		220		mVp-p	@ Max load <sup>2</sup>
6	Minimum Load <sup>3</sup>	$I_{LOAD}$	100			mA	
7	Short-Circuit Duration	$T_{SC}$			$\infty$	sec	
8	Efficiency @ 70% Load	EFF		87		%	
9	Isolation Voltage (I/O)	$V_{ISO}$			1500	$V_{PK}$	Impulse Test

Note 1: Typical figures are at 25°C with a nominal 48V supply and are for design aid only. Not Guaranteed

2: The output ripple and noise can be reduced with an external filter, see Section 5.8.

3: The module can emit an audible noise, if operated at less than the specified minimum  $I_{LOAD}$  and cause the PSE to fail its MPS.

## 12. Package

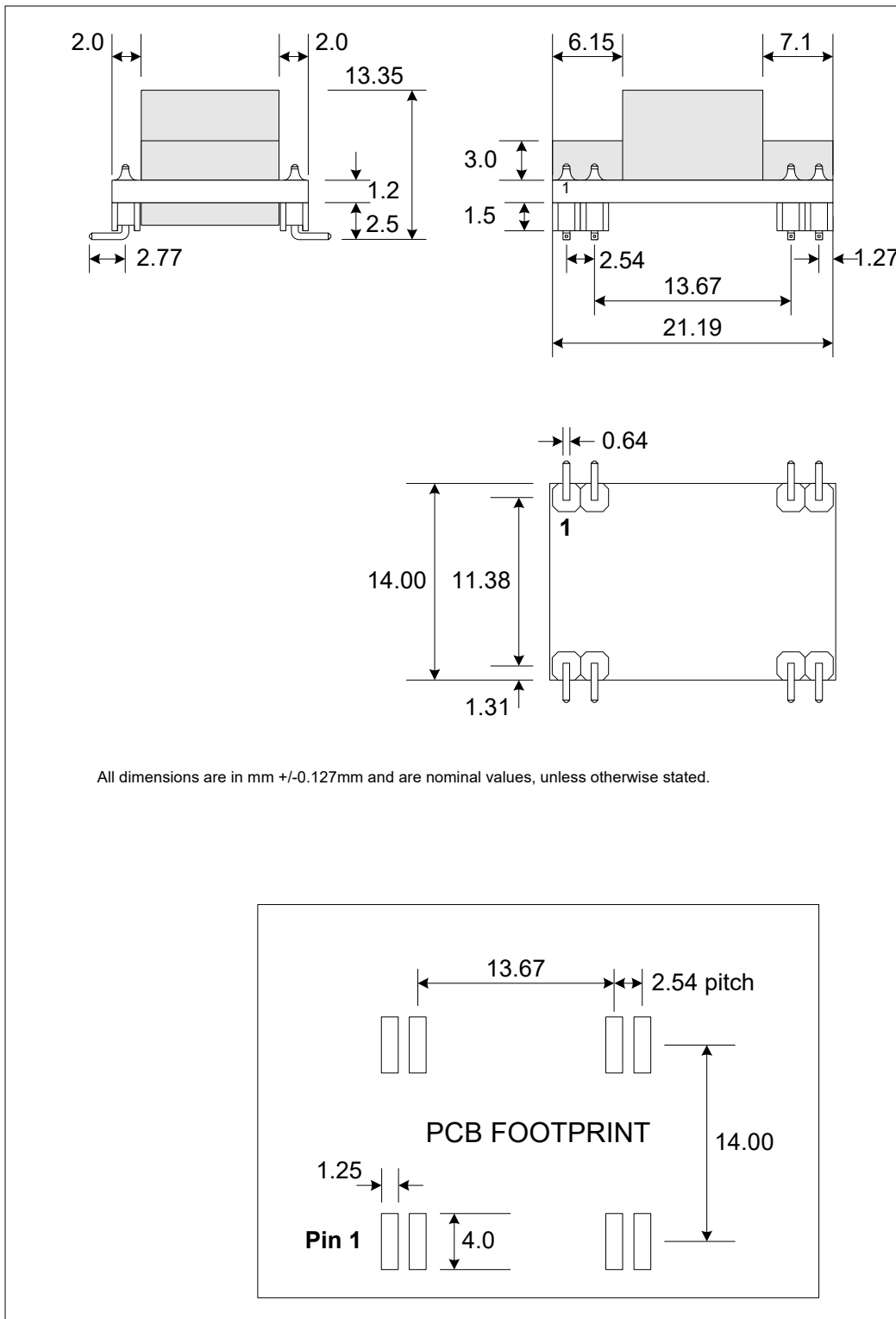

Information published in this datasheet is believed to be correct and accurate. Silver Telecom assumes no liability for errors which may occur or for liability otherwise arising out of use of this information or infringement of patents which may occur as a result of such use. No license is granted by this document under patents owned by Silver Telecom or licensed from third parties by Silver Telecom. The products, their specification and information appearing in this document are subject to change by Silver Telecom without notice.