



AiP74HC/HCT245 Octal Bus Transceiver; 3-state

Product Specification

Specification Revision History:

Version	Date	Description
2012-06-A1	2012-06	New
2021-12-A2	2021-12	Modify ordering information
2022-01-A3	2022-01	Modify ambient temperature to $-40^{\circ}\text{C} \sim +105^{\circ}\text{C}$ and add electrical characteristics of $-40^{\circ}\text{C} \sim +105^{\circ}\text{C}$
2022-06-A4	2022-06	Modify reel packing specifications (SOP20) in the ordering information



1、 General Description

The AiP74HC/HCT245 is an 8-bit transceiver with 3-state outputs. The device features an output enable (\overline{OE}) and send/receive (DIR) for direction control. A HIGH on \overline{OE} causes the outputs to assume a high-impedance OFF-state. Inputs include clamp diodes. This enables the use of current limiting resistors to interface inputs to voltages in excess of V_{CC} .

Features:

- Input levels:
 - For AiP74HC245: CMOS level
 - For AiP74HCT245: TTL level
- Octal bidirectional bus interface
- Non-inverting 3-state outputs
- Specified from -40°C to $+105^{\circ}\text{C}$
- Packaging information: DIP20/SOP20/TSSOP20

**Ordering Information:****Tube packing specifications:**

Part number	Packaging form	Marking code	Tube quantity	Boxed tube quantity	Boxed quantity	Notes
AiP74HC245DA20.TB	DIP20	74HC245	18 PCS/tube	40 tube/box	720 PCS/box	Dimensions of plastic enclosure: 26.3mm×6.4mm Pin spacing: 2.54mm
AiP74HCT245DA20.TB	DIP20	74HCT245	18 PCS/tube	40 tube/box	720 PCS/box	Dimensions of plastic enclosure: 26.3mm×6.4mm Pin spacing: 2.54mm
AiP74HC245SA20.TB	SOP20	74HC245	35 PCS/tube	80 tube/box	2800 PCS/box	Dimensions of plastic enclosure: 12.8mm×7.5mm Pin spacing: 1.27mm
AiP74HCT245SA20.TB	SOP20(1)	74HCT245	35 PCS/tube	80 tube/box	2800 PCS/box	Dimensions of plastic enclosure: 12.8mm×7.5mm Pin spacing: 1.27mm
AiP74HCT245SA20.TB	SOP20(2)	74HCT245	37 PCS/tube	100 tube/box	3700 PCS/box	Dimensions of plastic enclosure: 12.8mm×7.5mm Pin spacing: 1.27mm
AiP74HC245TA20.TB	TSSOP20(1)	74HC245	70 PCS/tube	200 tube/box	14000 PCS/box	Dimensions of plastic enclosure: 6.5mm×4.4mm Pin spacing: 0.65mm
AiP74HC245TA20.TB	TSSOP20(2)	74HC245	72 PCS/tube	100 tube/box	7200 PCS/box	Dimensions of plastic enclosure: 6.5mm×4.4mm Pin spacing: 0.65mm
AiP74HC245TA20.TB	TSSOP20(3)	74HC245	72 PCS/tube	140 tube/box	10080 PCS/box	Dimensions of plastic enclosure: 6.5mm×4.4mm Pin spacing: 0.65mm
AiP74HC245TA20.TB	TSSOP20(4)	74HC245	70 PCS/tube	140 tube/box	9800 PCS/box	Dimensions of plastic enclosure: 6.5mm×4.4mm Pin spacing: 0.65mm
AiP74HCT245TA20.TB	TSSOP20	74HCT245	70 PCS/tube	200 tube/box	14000 PCS/box	Dimensions of plastic enclosure: 6.5mm×4.4mm Pin spacing: 0.65mm

**Reel packing specifications:**

Part number	Packaging form	Marking code	Reel quantity	Boxed reel quantity	Notes
AiP74HC245SA20.TR	SOP20	74HC245	1000PCS/reel	1000PCS/box	Dimensions of plastic enclosure: 12.8mm×7.5mm Pin spacing: 1.27mm
AiP74HCT245SA20.TR	SOP20	74HCT245	2000PCS/reel	4000PCS/box	Dimensions of plastic enclosure: 12.8mm×7.5mm Pin spacing: 1.27mm
AiP74HC245TA20.TR	TSSOP20	74HC245	4000PCS/reel	8000PCS/box	Dimensions of plastic enclosure: 6.5mm×4.4mm Pin spacing: 0.65mm
AiP74HCT245TA20.TR	TSSOP20	74HCT245	4000PCS/reel	8000PCS/box	Dimensions of plastic enclosure: 6.5mm×4.4mm Pin spacing: 0.65mm

Note: If the physical information is inconsistent with the ordering information, please refer to the actual product.



2、Block Diagram And Pin Description

2.1、Block Diagram

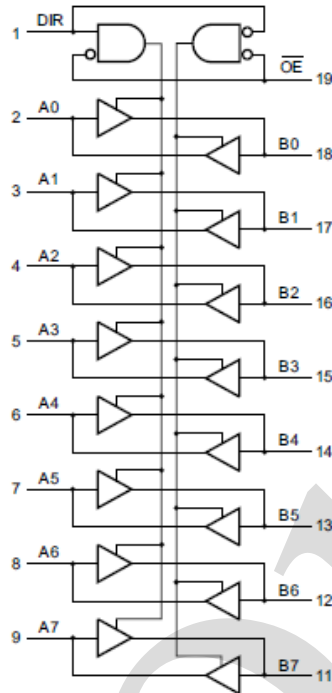

Figure 1. Logic symbol

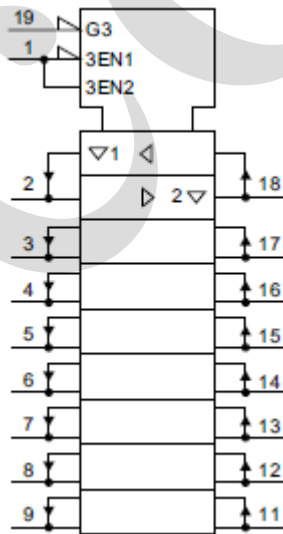
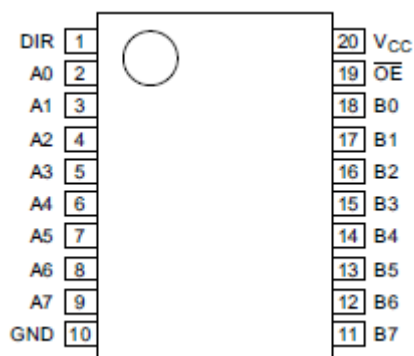

Figure 2. IEC logic symbol



2.2、Pin Configurations



2.3、Pin Description

Pin No.	Pin Name	Description
1	DIR	direction control
2	A0	data input/output
3	A1	data input/output
4	A2	data input/output
5	A3	data input/output
6	A4	data input/output
7	A5	data input/output
8	A6	data input/output
9	A7	data input/output
10	GND	ground (0V)
11	B7	data input/output
12	B6	data input/output
13	B5	data input/output
14	B4	data input/output
15	B3	data input/output
16	B2	data input/output
17	B1	data input/output
18	B0	data input/output
19	OE	output enable input (active LOW)
20	V _{CC}	supply voltage

2.4、Function Table

Input		Output	
OE	DIR	A _n	B _n
L	L	A=B	input
L	H	input	B=A
H	X	Z	Z

Note: H=HIGH voltage level; L=LOW voltage level; X=don't care; Z=high-impedance OFF-state.



3、Electrical Parameter

3.1、Absolute Maximum Ratings

(Voltages are referenced to GND(ground=0V), unless otherwise specified.)

Parameter	Symbol	Conditions	Min.	Max.	Unit
supply voltage	V_{CC}	-	-0.5	+7.0	V
input clamping current	I_{IK}	$V_I < -0.5V$ or $V_I > V_{CC}+0.5V$	-	± 20	mA
output clamping current	I_{OK}	$V_O < -0.5V$ or $V_O > V_{CC}+0.5V$	-	± 20	mA
output current	I_O	$-0.5V < V_O < V_{CC}+0.5V$	-	± 35	mA
supply current	I_{CC}	-	-	70	mA
ground current	I_{GND}	-	-70	-	mA
storage temperature	T_{stg}	-	-65	+150	°C
total power dissipation	P_{tot}	-	-	500	mW
Soldering temperature	T_L	10s	DIP	245	°C
			SOP	250	°C

Note:

[1] For DIP20 packages: above 70°C the value of P_{tot} derates linearly with 12mW/K.

[2] For SOP20 packages: above 70°C the value of P_{tot} derates linearly with 8mW/K.

[3] For (T)SSOP20 packages: above 60°C the value of P_{tot} derates linearly with 5.5mW/K.

3.2、Recommended Operating Conditions

Parameter	Symbol	Conditions	Min.	Typ.	Max.	Unit
AiP74HC245						
supply voltage	V_{CC}	-	2.0	5.0	6.0	V
input voltage	V_I	-	0	-	V_{CC}	V
output voltage	V_O	-	0	-	V_{CC}	V
input transition rise and fall rate	$\Delta t/\Delta V$	$V_{CC}=2.0V$	-	-	625	ns/V
		$V_{CC}=4.5V$	-	1.67	139	ns/V
		$V_{CC}=6.0V$	-	-	83	ns/V
ambient temperature	T_{amb}	-	-40	-	+105	°C
AiP74HCT245						
supply voltage	V_{CC}	-	4.5	5.0	5.5	V
input voltage	V_I	-	0	-	V_{CC}	V
output voltage	V_O	-	0	-	V_{CC}	V
input transition rise and fall rate	$\Delta t/\Delta V$	$V_{CC}=4.5V$	-	1.67	139	ns/V
ambient temperature	T_{amb}	-	-40	-	+105	°C



3.3、Electrical Characteristics

3.3.1、DC Characteristics 1

($T_{amb}=25^{\circ}C$, voltages are referenced to GND (ground=0V), unless otherwise specified.)

Parameter	Symbol	Conditions	Min.	Typ.	Max.	Unit	
AiP74HC245							
HIGH-level input voltage	V_{IH}	$V_{CC}=2.0V$	1.5	1.2	-	V	
		$V_{CC}=4.5V$	3.15	2.4	-	V	
		$V_{CC}=6.0V$	4.2	3.2	-	V	
LOW-level input voltage	V_{IL}	$V_{CC}=2.0V$	-	0.8	0.5	V	
		$V_{CC}=4.5V$	-	2.1	1.35	V	
		$V_{CC}=6.0V$	-	2.8	1.8	V	
HIGH-level output voltage	V_{OH}	$V_I = V_{IH} \text{ or } V_{IL}$	$I_O=-20\mu A; V_{CC}=2.0V$	1.9	2.0	-	V
			$I_O=-20\mu A; V_{CC}=4.5V$	4.4	4.5	-	V
			$I_O=-20\mu A; V_{CC}=6.0V$	5.9	6.0	-	V
			$I_O=-6.0mA; V_{CC}=4.5V$	3.98	4.32	-	V
			$I_O=-7.8mA; V_{CC}=6.0V$	5.48	5.81	-	V
LOW-level output voltage	V_{OL}	$V_I = V_{IH} \text{ or } V_{IL}$	$I_O=20\mu A; V_{CC}=2.0V$	-	0	0.1	V
			$I_O=20\mu A; V_{CC}=4.5V$	-	0	0.1	V
			$I_O=20\mu A; V_{CC}=6.0V$	-	0	0.1	V
			$I_O=6.0mA; V_{CC}=4.5V$	-	0.15	0.26	V
			$I_O=7.8mA; V_{CC}=6.0V$	-	0.16	0.26	V
input leakage current	I_I	$V_I=V_{CC} \text{ or } GND;$ $V_{CC}=6.0V$	-	-	± 0.1	μA	
OFF-state output current	I_{OZ}	$V_I=V_{IH} \text{ or } V_{IL}; V_{CC}=6.0V;$ $V_O=V_{CC} \text{ or } GND$	-	-	± 0.5	μA	
supply current	I_{CC}	$V_I=V_{CC} \text{ or } GND; I_O=0A; V_{CC}=6.0V$	-	-	8.0	μA	
input capacitance	C_I	-	-	3.5	-	pF	
input/output capacitance	$C_{I/O}$	-	-	10	-	pF	
AiP74HCT245							
HIGH-level input voltage	V_{IH}	$V_{CC}=4.5V \text{ to } 5.5V$	2.0	1.6	-	V	
LOW-level input voltage	V_{IL}	$V_{CC}=4.5V \text{ to } 5.5V$	-	1.2	0.8	V	
HIGH-level output voltage	V_{OH}	$V_I = V_{IH} \text{ or } V_{IL};$ $V_{CC}=4.5V$	$I_O=-20\mu A$	4.4	4.5	-	V
			$I_O=-6.0mA$	3.98	4.32	-	V
LOW-level output voltage	V_{OL}	$V_I = V_{IH} \text{ or } V_{IL};$ $V_{CC}=4.5V$	$I_O=20\mu A$	-	0	0.1	V
			$I_O=6.0mA$	-	0.15	0.26	V
input leakage current	I_I	$V_I=V_{CC} \text{ or } GND;$ $V_{CC}=5.5V$	-	-	± 0.1	μA	
OFF-state output current	I_{OZ}	$V_I=V_{IH} \text{ or } V_{IL}; V_{CC}=5.5V;$ $V_O=V_{CC} \text{ or } GND$	-	-	± 0.5	μA	
supply current	I_{CC}	$V_I=V_{CC} \text{ or } GND; I_O=0A; V_{CC}=5.5V$	-	-	8.0	μA	
additional supply current	ΔI_{CC}	per input pin; $V_I=V_{CC}-2.1V;$ other inputs at V_{CC} or GND; $V_{CC}=4.5V$ to $5.5V; I_O=0A$	An or Bn inputs	-	40	144	μA
			$\bar{O}E$ input	-	150	540	μA
			DIR input	-	90	324	μA



input capacitance	C_I	-	-	3.5	-	pF
input/output capacitance	$C_{I/O}$	-	-	10	-	pF

3.3.2、DC Characteristics 2

($T_{amb}=-40^{\circ}\text{C}$ to $+85^{\circ}\text{C}$, voltages are referenced to GND (ground=0V), unless otherwise specified.)

Parameter	Symbol	Conditions	Min.	Typ.	Max.	Unit	
AiP74HC245							
HIGH-level input voltage	V_{IH}	$V_{CC}=2.0\text{V}$	1.5	-	-	V	
		$V_{CC}=4.5\text{V}$	3.15	-	-	V	
		$V_{CC}=6.0\text{V}$	4.2	-	-	V	
LOW-level input voltage	V_{IL}	$V_{CC}=2.0\text{V}$	-	-	0.5	V	
		$V_{CC}=4.5\text{V}$	-	-	1.35	V	
		$V_{CC}=6.0\text{V}$	-	-	1.8	V	
HIGH-level output voltage	V_{OH}	$V_I = V_{IH} \text{ or } V_{IL}$	$I_O=-20\mu\text{A}; V_{CC}=2.0\text{V}$	1.9	-	-	V
			$I_O=-20\mu\text{A}; V_{CC}=4.5\text{V}$	4.4	-	-	V
			$I_O=-20\mu\text{A}; V_{CC}=6.0\text{V}$	5.9	-	-	V
			$I_O=-6.0\text{mA}; V_{CC}=4.5\text{V}$	3.84	-	-	V
			$I_O=-7.8\text{mA}; V_{CC}=6.0\text{V}$	5.34	-	-	V
LOW-level output voltage	V_{OL}	$V_I = V_{IH} \text{ or } V_{IL}$	$I_O=20\mu\text{A}; V_{CC}=2.0\text{V}$	-	-	0.1	V
			$I_O=20\mu\text{A}; V_{CC}=4.5\text{V}$	-	-	0.1	V
			$I_O=20\mu\text{A}; V_{CC}=6.0\text{V}$	-	-	0.1	V
			$I_O=6.0\text{mA}; V_{CC}=4.5\text{V}$	-	-	0.33	V
			$I_O=7.8\text{mA}; V_{CC}=6.0\text{V}$	-	-	0.33	V
input leakage current	I_I	$V_I=V_{CC} \text{ or } \text{GND}; V_{CC}=6.0\text{V}$	-	-	± 1.0	μA	
OFF-state output current	I_{OZ}	$V_I=V_{IH} \text{ or } V_{IL}; V_{CC}=6.0\text{V}; V_O=V_{CC} \text{ or } \text{GND}$	-	-	± 5.0	μA	
supply current	I_{CC}	$V_I=V_{CC} \text{ or } \text{GND}; I_O=0\text{A}; V_{CC}=6.0\text{V}$	-	-	80	μA	
AiP74HCT245							
HIGH-level input voltage	V_{IH}	$V_{CC}=4.5\text{V to } 5.5\text{V}$	2.0	-	-	V	
LOW-level input voltage	V_{IL}	$V_{CC}=4.5\text{V to } 5.5\text{V}$	-	-	0.8	V	
HIGH-level output voltage	V_{OH}	$V_I = V_{IH} \text{ or } V_{IL}; V_{CC}=4.5\text{V}$	$I_O=-20\mu\text{A}$	4.4	-	-	V
			$I_O=-6.0\text{mA}$	3.84	-	-	V
LOW-level output voltage	V_{OL}	$V_I = V_{IH} \text{ or } V_{IL}; V_{CC}=4.5\text{V}$	$I_O=20\mu\text{A}$	-	-	0.1	V
			$I_O=6.0\text{mA}$	-	-	0.33	V
input leakage current	I_I	$V_I=V_{CC} \text{ or } \text{GND}; V_{CC}=5.5\text{V}$	-	-	± 1.0	μA	
OFF-state output current	I_{OZ}	$V_I=V_{IH} \text{ or } V_{IL}; V_{CC}=5.5\text{V}; V_O=V_{CC} \text{ or } \text{GND}$	-	-	± 5.0	μA	
supply current	I_{CC}	$V_I=V_{CC} \text{ or } \text{GND}; I_O=0\text{A}; V_{CC}=5.5\text{V}$	-	-	80	μA	
additional supply current	ΔI_{CC}	per input pin; $V_I=V_{CC}-2.1\text{V};$ other inputs at V_{CC}	An or Bn inputs	-	-	180	μA
			$\bar{\text{OE}}$ input	-	-	675	μA



		or GND; $V_{CC}=4.5V$ to $5.5V$; $I_O=0A$	DIR input	-	-	405	uA
--	--	--	-----------	---	---	-----	----

3.3.3、DC Characteristics 3

($T_{amb}=-40^{\circ}C$ to $+105^{\circ}C$, voltages are referenced to GND (ground=0V), unless otherwise specified.)

Parameter	Symbol	Conditions	Min.	Typ.	Max.	Unit	
AiP74HC245							
HIGH-level input voltage	V_{IH}	$V_{CC}=2.0V$	1.5	-	-	V	
		$V_{CC}=4.5V$	3.15	-	-	V	
		$V_{CC}=6.0V$	4.2	-	-	V	
LOW-level input voltage	V_{IL}	$V_{CC}=2.0V$	-	-	0.5	V	
		$V_{CC}=4.5V$	-	-	1.35	V	
		$V_{CC}=6.0V$	-	-	1.8	V	
HIGH-level output voltage	V_{OH}	$V_I = V_{IH} \text{ or } V_{IL}$	$I_O=-20\mu A$; $V_{CC}=2.0V$	1.9	-	-	V
			$I_O=-20\mu A$; $V_{CC}=4.5V$	4.4	-	-	V
			$I_O=-20\mu A$; $V_{CC}=6.0V$	5.9	-	-	V
			$I_O=-6.0mA$; $V_{CC}=4.5V$	3.7	-	-	V
			$I_O=-7.8mA$; $V_{CC}=6.0V$	5.2	-	-	V
LOW-level output voltage	V_{OL}	$V_I = V_{IH} \text{ or } V_{IL}$	$I_O=20\mu A$; $V_{CC}=2.0V$	-	-	0.1	V
			$I_O=20\mu A$; $V_{CC}=4.5V$	-	-	0.1	V
			$I_O=20\mu A$; $V_{CC}=6.0V$	-	-	0.1	V
			$I_O=6.0mA$; $V_{CC}=4.5V$	-	-	0.4	V
			$I_O=7.8mA$; $V_{CC}=6.0V$	-	-	0.4	V
input leakage current	I_I	$V_I=V_{CC}$ or GND; $V_{CC}=6.0V$	-	-	± 1.0	μA	
OFF-state output current	I_{OZ}	$V_I=V_{IH}$ or V_{IL} ; $V_{CC}=6.0V$; $V_O=V_{CC}$ or GND	-	-	± 10	μA	
supply current	I_{CC}	$V_I=V_{CC}$ or GND; $I_O=0A$; $V_{CC}=6.0V$	-	-	160	μA	
AiP74HCT245							
HIGH-level input voltage	V_{IH}	$V_{CC}=4.5V$ to $5.5V$	2.0	-	-	V	
LOW-level input voltage	V_{IL}	$V_{CC}=4.5V$ to $5.5V$	-	-	0.8	V	
HIGH-level output voltage	V_{OH}	$V_I = V_{IH} \text{ or } V_{IL}$; $V_{CC}=4.5V$	$I_O=-20\mu A$	4.4	-	-	V
			$I_O=-6.0mA$	3.7	-	-	V
LOW-level output voltage	V_{OL}	$V_I = V_{IH} \text{ or } V_{IL}$; $V_{CC}=4.5V$	$I_O=20\mu A$	-	-	0.1	V
			$I_O=6.0mA$	-	-	0.4	V
input leakage current	I_I	$V_I=V_{CC}$ or GND; $V_{CC}=5.5V$	-	-	± 1.0	μA	
OFF-state output current	I_{OZ}	$V_I=V_{IH}$ or V_{IL} ; $V_{CC}=5.5V$; $V_O=V_{CC}$ or GND	-	-	± 10	μA	
supply current	I_{CC}	$V_I=V_{CC}$ or GND; $I_O=0A$; $V_{CC}=5.5V$	-	-	160	μA	
additional supply current	ΔI_{CC}	per input pin; $V_I=V_{CC}-2.1V$; other inputs at V_{CC} or GND; $V_{CC}=4.5V$ to $5.5V$; $I_O=0A$	An or Bn inputs	-	-	196	μA
			$\bar{O}E$ input	-	-	735	μA
			DIR input	-	-	441	μA



3.3.4、AC Characteristics 1

($T_{amb}=25^{\circ}\text{C}$, voltages are referenced to GND (ground=0V), unless otherwise specified.)

Parameter	Symbol	Conditions	Min.	Typ.	Max.	Unit	
AiP74HC245							
An to Bn or Bn to An propagation delay	t_{pd}	see Figure 4	$V_{CC}=2.0\text{V}$	-	25	90	ns
			$V_{CC}=4.5\text{V}$	-	9	18	ns
			$V_{CC}=5.0\text{V}; C_L=15\text{pF}$	-	7	-	ns
			$V_{CC}=6.0\text{V}$	-	7	15	ns
$\overline{\text{OE}}$ to An or Bn enable time	t_{en}	see Figure 5	$V_{CC}=2.0\text{V}$	-	30	150	ns
			$V_{CC}=4.5\text{V}$	-	11	30	ns
			$V_{CC}=6.0\text{V}$	-	9	26	ns
$\overline{\text{OE}}$ to An or Bn disable time	t_{dis}	see Figure 5	$V_{CC}=2.0\text{V}$	-	41	150	ns
			$V_{CC}=4.5\text{V}$	-	15	30	ns
			$V_{CC}=6.0\text{V}$	-	12	26	ns
transition time	t_t	see Figure 4	$V_{CC}=2.0\text{V}$	-	14	60	ns
			$V_{CC}=4.5\text{V}$	-	5	12	ns
			$V_{CC}=6.0\text{V}$	-	4	10	ns
power dissipation capacitance	C_{PD}	per buffer; $V_I=\text{GND to } V_{CC}$	-	30	-	pF	
AiP74HCT245							
An to Bn or Bn to An propagation delay	t_{pd}	see Figure 4	$V_{CC}=4.5\text{V}$	-	12	22	ns
			$V_{CC}=5.0\text{V}; C_L=15\text{pF}$	-	10	-	ns
$\overline{\text{OE}}$ to An or Bn enable time	t_{en}	$V_{CC}=4.5\text{V};$ see Figure 5	-	16	30	ns	
$\overline{\text{OE}}$ to An or Bn disable time	t_{dis}	$V_{CC}=4.5\text{V};$ see Figure 5	-	16	30	ns	
transition time	t_t	$V_{CC}=4.5\text{V};$ see Figure 4	-	5	12	ns	
power dissipation capacitance	C_{PD}	per buffer; $V_I=\text{GND to } V_{CC}-1.5\text{V}$	-	30	-	pF	

Note:

[1] t_{pd} is the same as t_{PLH} and t_{PHL} .

[2] t_{en} is the same as t_{PZL} and t_{PZH} .

[3] t_{dis} is the same as t_{PLZ} and t_{PHZ} .

[4] t_t is the same as t_{THL} and t_{TLH} .

[5] C_{PD} is used to determine the dynamic power dissipation (P_D in uW).

$$P_D = C_{PD} \times V_{CC}^2 \times f_i \times N + \sum (C_L \times V_{CC}^2 \times f_o) \text{ where:}$$

f_i =input frequency in MHz;

f_o =output frequency in MHz;

C_L =output load capacitance in pF;

V_{CC} =supply voltage in V;

N =number of inputs switching;

$\sum (C_L \times V_{CC}^2 \times f_o)$ =sum of outputs.



3.3.5、 AC Characteristics 2

($T_{amb} = -40^{\circ}\text{C}$ to $+85^{\circ}\text{C}$, voltages are referenced to GND (ground=0V), unless otherwise specified.)

Parameter	Symbol	Conditions	Min.	Typ.	Max.	Unit	
AiP74HC245							
An to Bn or Bn to An propagation delay	t_{pd}	see Figure 4	$V_{CC}=2.0\text{V}$	-	-	115	ns
			$V_{CC}=4.5\text{V}$	-	-	23	ns
			$V_{CC}=6.0\text{V}$	-	-	20	ns
$\overline{\text{OE}}$ to An or Bn enable time	t_{en}	see Figure 5	$V_{CC}=2.0\text{V}$	-	-	190	ns
			$V_{CC}=4.5\text{V}$	-	-	38	ns
			$V_{CC}=6.0\text{V}$	-	-	33	ns
$\overline{\text{OE}}$ to An or Bn disable time	t_{dis}	see Figure 5	$V_{CC}=2.0\text{V}$	-	-	190	ns
			$V_{CC}=4.5\text{V}$	-	-	38	ns
			$V_{CC}=6.0\text{V}$	-	-	33	ns
transition time	t_t	see Figure 4	$V_{CC}=2.0\text{V}$	-	-	75	ns
			$V_{CC}=4.5\text{V}$	-	-	15	ns
			$V_{CC}=6.0\text{V}$	-	-	13	ns
AiP74HCT245							
An to Bn or Bn to An propagation delay	t_{pd}	see Figure 4	$V_{CC}=4.5\text{V}$	-	-	28	ns
$\overline{\text{OE}}$ to An or Bn enable time	t_{en}	$V_{CC}=4.5\text{V}$; see Figure 5		-	-	38	ns
$\overline{\text{OE}}$ to An or Bn disable time	t_{dis}	$V_{CC}=4.5\text{V}$; see Figure 5		-	-	38	ns
transition time	t_t	$V_{CC}=4.5\text{V}$; see Figure 4		-	-	15	ns

Note:

- [1] t_{pd} is the same as t_{PLH} and t_{PHL} .
- [2] t_{en} is the same as t_{PZL} and t_{PZH} .
- [3] t_{dis} is the same as t_{PLZ} and t_{PHZ} .
- [4] t_t is the same as t_{THL} and t_{TLH} .



3.3.6、AC Characteristics 3

($T_{amb} = -40^{\circ}\text{C}$ to $+105^{\circ}\text{C}$, voltages are referenced to GND (ground=0V), unless otherwise specified.)

Parameter	Symbol	Conditions	Min.	Typ.	Max.	Unit	
AiP74HC245							
An to Bn or Bn to An propagation delay	t_{pd}	see Figure 4	$V_{CC}=2.0\text{V}$	-	-	135	ns
			$V_{CC}=4.5\text{V}$	-	-	27	ns
			$V_{CC}=6.0\text{V}$	-	-	23	ns
$\overline{\text{OE}}$ to An or Bn enable time	t_{en}	see Figure 5	$V_{CC}=2.0\text{V}$	-	-	225	ns
			$V_{CC}=4.5\text{V}$	-	-	45	ns
			$V_{CC}=6.0\text{V}$	-	-	38	ns
$\overline{\text{OE}}$ to An or Bn disable time	t_{dis}	see Figure 5	$V_{CC}=2.0\text{V}$	-	-	225	ns
			$V_{CC}=4.5\text{V}$	-	-	45	ns
			$V_{CC}=6.0\text{V}$	-	-	38	ns
transition time	t_t	see Figure 4	$V_{CC}=2.0\text{V}$	-	-	90	ns
			$V_{CC}=4.5\text{V}$	-	-	18	ns
			$V_{CC}=6.0\text{V}$	-	-	15	ns
AiP74HCT245							
An to Bn or Bn to An propagation delay	t_{pd}	see Figure 4	$V_{CC}=4.5\text{V}$	-	-	33	ns
$\overline{\text{OE}}$ to An or Bn enable time	t_{en}	$V_{CC}=4.5\text{V}$; see Figure 5		-	-	45	ns
$\overline{\text{OE}}$ to An or Bn disable time	t_{dis}	$V_{CC}=4.5\text{V}$; see Figure 5		-	-	45	ns
transition time	t_t	$V_{CC}=4.5\text{V}$; see Figure 4		-	-	18	ns

Note:

[1] t_{pd} is the same as t_{PLH} and t_{PHL} .

[2] t_{en} is the same as t_{PZL} and t_{PZH} .

[3] t_{dis} is the same as t_{PLZ} and t_{PHZ} .

[4] t_t is the same as t_{THL} and t_{TLH} .



4、 Testing Circuit

4.1、 AC Testing Circuit

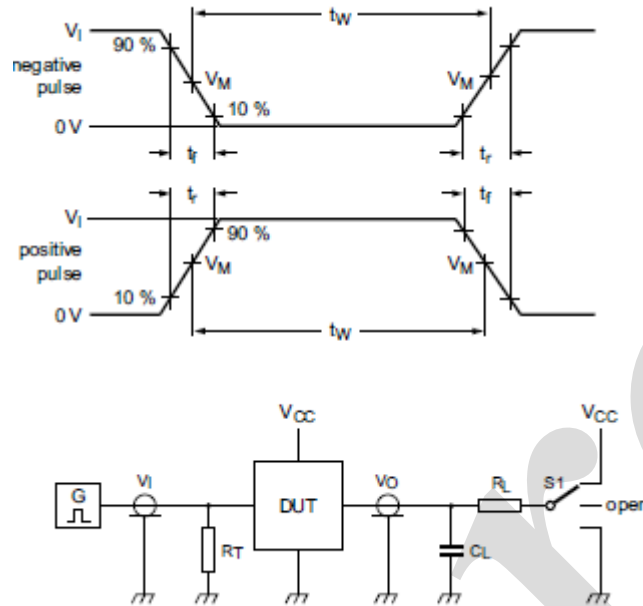

Figure 3. Test circuit for measuring switching times

Definitions for test circuit:

R_L =Load resistance.

C_L =Load capacitance including jig and probe capacitance.

R_T =Termination resistance should be equal to the output impedance Z_o of the pulse generator.

S1=Test selection switch.

4.2、 AC Testing Waveforms

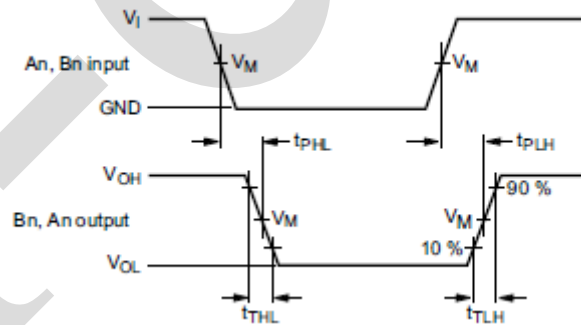

Figure 4. Input (An, Bn) to output (Bn, An) propagation delays and output transition times

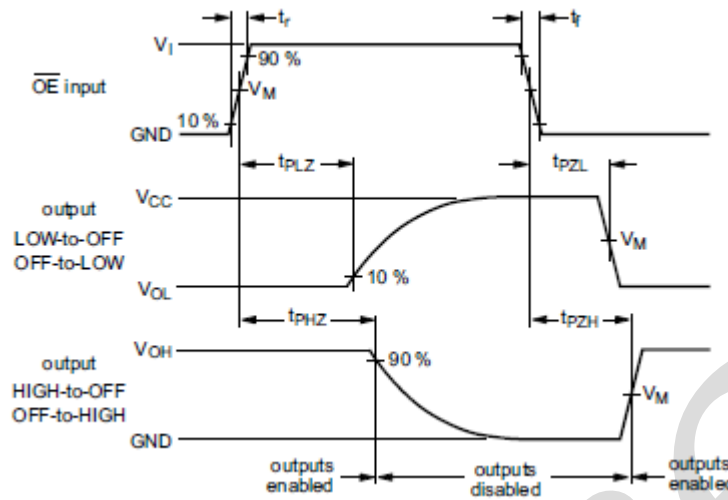

Figure 5. 3-state enable and disable times

4.3. Measurement Points

Type	Input	Output
	V_M	V_M
AiP74HC245	$0.5 \times V_{CC}$	$0.5 \times V_{CC}$
AiP74HCT245	1.3V	1.3V

4.4. Test Data

Type	Input		Load		S1 position		
	V_I	t_r, t_f	C_L	R_L	t_{PHL}, t_{PLH}	t_{PZH}, t_{PHZ}	t_{PZL}, t_{PLZ}
AiP74HC245	V_{CC}	6ns	15pF, 50pF	1k Ω	open	GND	V_{CC}
AiP74HCT245	3V	6ns	15pF, 50pF	1k Ω	open	GND	V_{CC}



5、Package Information

5.1、DIP20

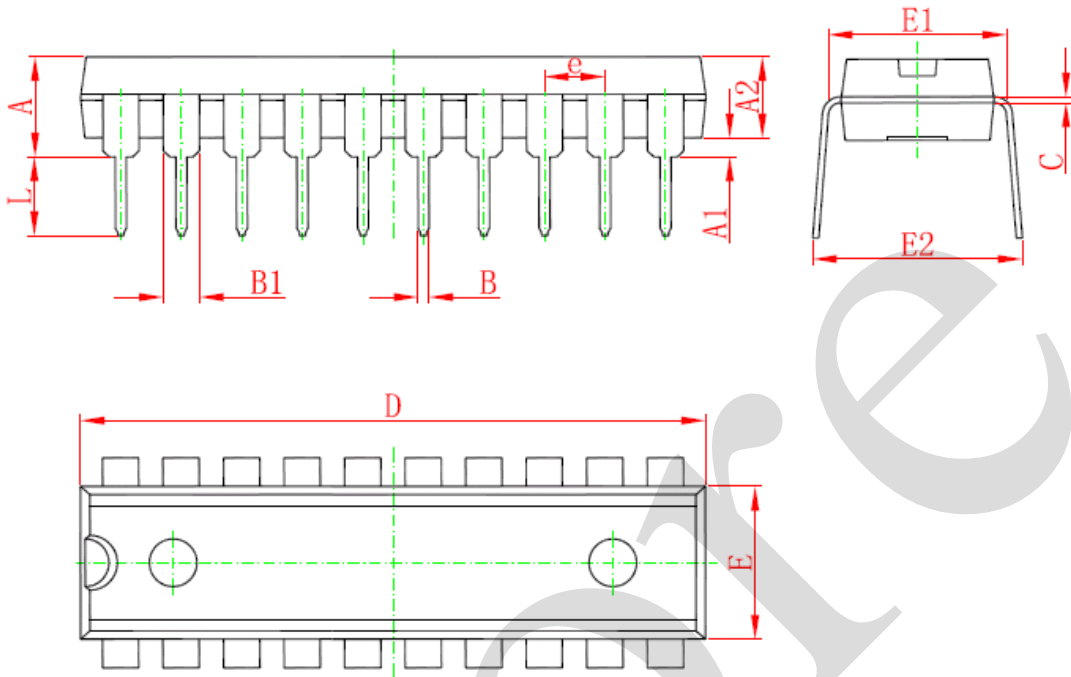

Symbol	Dimensions In Millimeters		Dimensions In Inches	
	Min	Max	Min	Max
A	3.710	4.310	0.146	0.170
A1	0.510		0.020	
A2	3.200	3.600	0.126	0.142
B	0.380	0.570	0.015	0.022
B1	1.524 (BSC)		0.060 (BSC)	
C	0.204	0.360	0.008	0.014
D	25.950	26.550	1.022	1.045
E	6.200	6.600	0.244	0.260
E1	7.320	7.920	0.288	0.312
e	2.540 (BSC)		0.100 (BSC)	
L	3.000	3.600	0.118	0.142
E2	8.400	9.000	0.331	0.354



5.2、SOP20

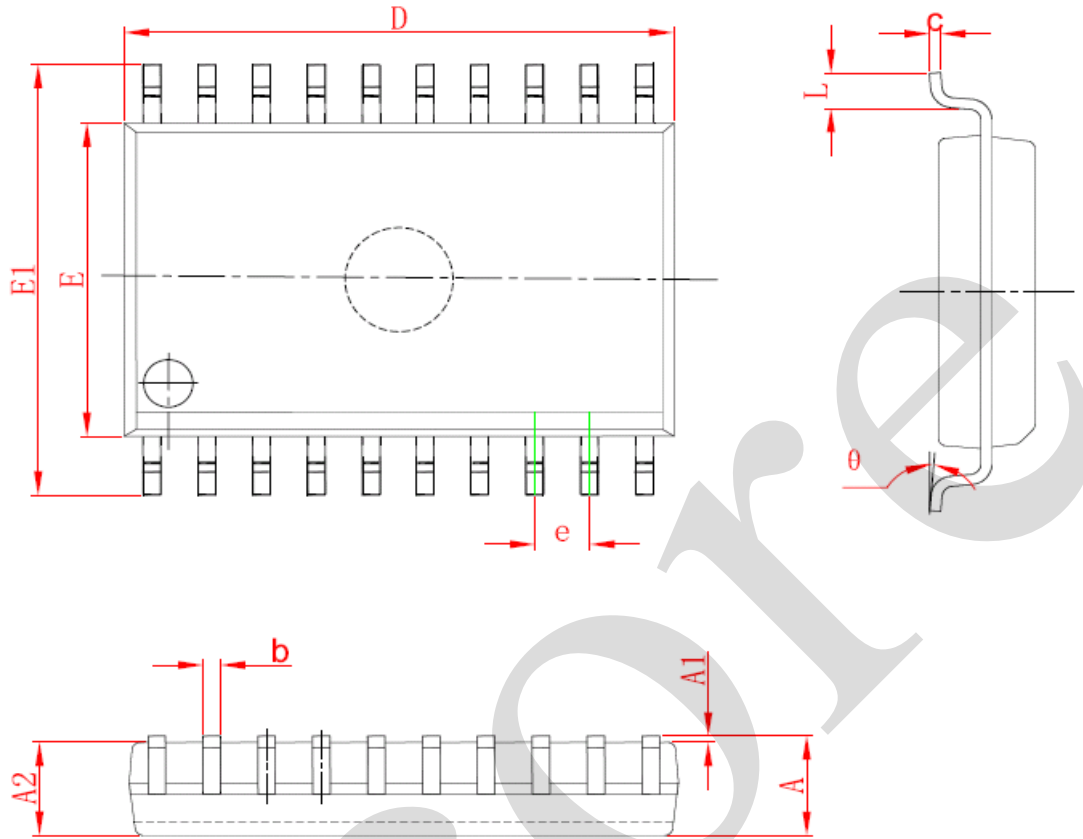

Symbol	Dimensions In Millimeters		Dimensions In Inches	
	Min	Max	Min	Max
A	2.350	2.650	0.093	0.104
A1	0.100	0.300	0.004	0.012
A2	2.100	2.500	0.083	0.098
b	0.330	0.510	0.013	0.020
c	0.204	0.330	0.008	0.013
D	12.520	13.000	0.493	0.512
E	7.400	7.600	0.291	0.299
E1	10.210	10.610	0.402	0.418
e	1.270 (BSC)		0.050 (BSC)	
L	0.400	1.270	0.016	0.050
θ	0°	8°	0°	8°



5.3、TSSOP20

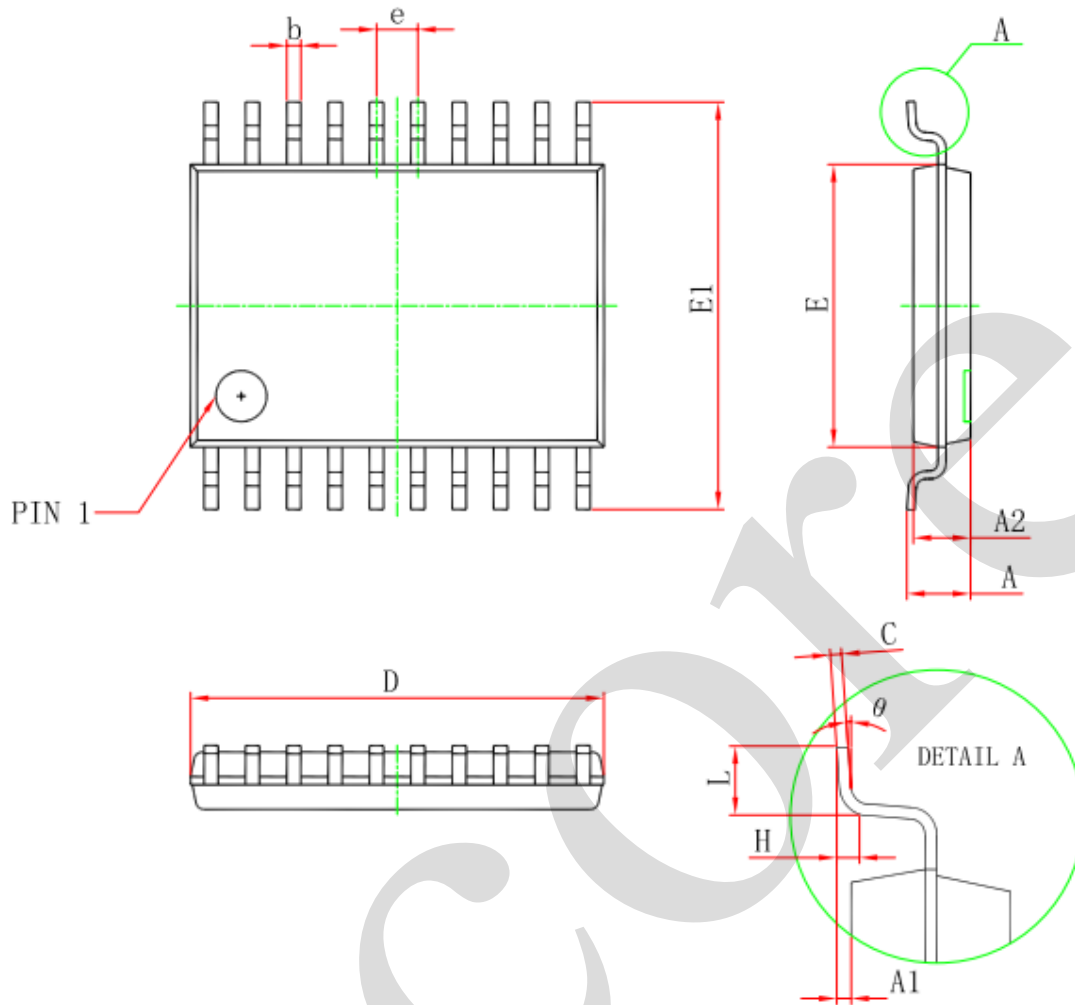

Symbol	Dimensions In Millimeters		Dimensions In Inches	
	Min	Max	Min	Max
D	6.400	6.600	0.252	0.259
E	4.300	4.500	0.169	0.177
b	0.190	0.300	0.007	0.012
e	0.090	0.200	0.004	0.008
E1	6.250	6.550	0.246	0.258
A		1.200		0.047
A2	0.800	1.000	0.031	0.039
A1	0.050	0.150	0.002	0.006
e	0.65 (BSC)		0.026 (BSC)	
L	0.500	0.700	0.020	0.028
H	0.25(TYP)		0.01(TYP)	
θ	1°	7°	1°	7°



6、 Statements And Notes

6.1、 The name and content of Hazardous substances or Elements in the product

Part name	Hazardous substances or Elements									
	Lead and lead compounds	Mercury and mercury compounds	Cadmium and cadmium compounds	Hexavalent chromium compounds	Polybrominated biphenyls	Polybrominated biphenyl ethers	Dibutyl phthalate	Butylbenzyl phthalate	Di-2-ethylhexyl phthalate	Diisobutyl phthalate
Lead frame	○	○	○	○	○	○	○	○	○	○
Plastic resin	○	○	○	○	○	○	○	○	○	○
Chip	○	○	○	○	○	○	○	○	○	○
The lead	○	○	○	○	○	○	○	○	○	○
Plastic sheet installed	○	○	○	○	○	○	○	○	○	○
explanation	○: Indicates that the content of hazardous substances or elements in the detection limit of the following the SJ/T11363-2006 standard. ×: Indicates that the content of hazardous substances or elements exceeding the SJ/T11363-2006 Standard limit requirements.									

6.2、 Notion

Recommended carefully reading this information before the use of this product;

The information in this document are subject to change without notice;

This information is using to the reference only, the company is not responsible for any loss;

The company is not responsible for the any infringement of the third party patents or other rights of the responsibility.