

Am1402A/Am1403A/Am1404A Am2802/Am2803/Am2804

1024-Bit Dynamic Shift Registers

Distinctive Characteristics

- Quad 256-bit, dual 512-bit, single 1024-bit
- 10 MHz frequency operation guaranteed for Am2802, Am2803 and Am2804.
- Low power dissipation of 0.1 mW/bit at 1 MHz
- DTL and TTL compatible
- Both military and commercial grade devices available
- 100% reliability assurance testing in compliance with MIL-STD-883.
- Electrically tested and optically inspected die for the assemblers of hybrid products

FUNCTIONAL DESCRIPTION

The Am1402A, 3A, and 4A are 1024-bit silicon gate dynamic shift registers. The low threshold characteristics of this technology allow high-speed operation and DTL and TTL compatibility. The Am1402A is a quad 256-bit device; the Am1403A is a dual 512-bit register; and the Am1404A is a

single 1024-bit register. All three devices require two-phase non-overlapping clocks, and provide a one-bit shift on each clock pulse. The Am2802, 3, and 4 registers are functionally identical to the Am1402A, 3A, and 4A, but are guaranteed to operate over frequencies from 400 Hz to 10 MHz.

BLOCK DIAGRAMS

Am1402A/1403A/1404A Shift Registers

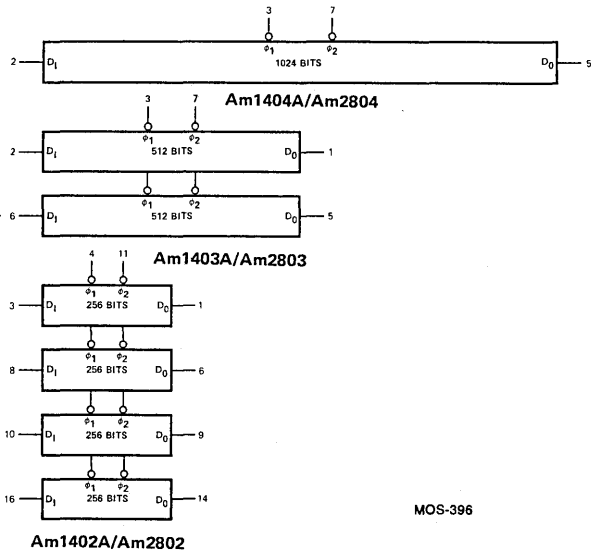

Functional Equivalent of Each Register

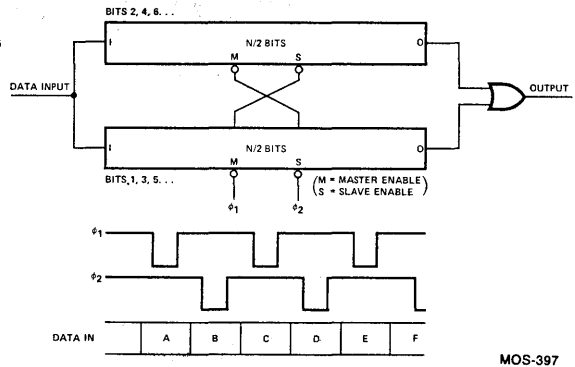

Since the two registers shift on opposite clock pulses, a new data bit is entered on both ϕ_1 and ϕ_2 . Data entering the register on ϕ_1 will appear at the output on ϕ_1 (from the negative edge of ϕ_1 to the negative edge of ϕ_2).

ORDERING INFORMATION

Part Number	Package Type	Temperature Range	Standard Speed Range Order Number	Extended Speed Range Order Number
Am1402A/ 2802	Hermetic DIP	0°C to +70°C	AM1402A	AM2802DC
	Hermetic DIP	-55°C to +125°C	AM1402ADM	AM2802DM
	Molded DIP	0°C to +70°C	AM1402APC	AM2802PC
Am1403A/ 2803	TO-99	0°C to +70°C	AM1403A	AM2803HC
	TO-99	-55°C to +125°C	AM1403AHM	AM2803HM
	Molded DIP	0°C to +70°C	AM1403APC	AM2803PC
Am1404A/ 2804	TO-99	0°C to +70°C	AM1404A	AM2804HC
	TO-99	-55°C to +125°C	AM1404AHM	AM2804HM
	Mini DIP Plastic	0°C to +70°C	AM1404APC	AM2804PC

Am1402A/03A/04A • Am2802/03/04

MAXIMUM RATINGS (Above which the useful life may be impaired)

Storage Temperature	-65°C to +160°C
Temperature Under Bias	-55°C to +125°C
Power Dissipation (Note 1)	600 mW
Data and Clock Input Voltages with respect to most Positive Supply Voltage, V_{CC}	0.3 V to -20 V
Power Supply Voltage, V_{DD} with respect to V_{CC}	0.3 V to -20 V

OPERATING RANGE

Part Number	V_{CC}	V_{DD}	Temperature Range
Am1402A, Am1403A, Am1404A	5V ±5%	-4.75V to -9.45V	0°C to +70°C
Am1402ADM, Am1403AHM, Am1404AHM	5V ±5%	-4.75V to -9.45V	-55°C to +125°C
Am2802DC, Am2803HC, Am2804HC	5V ±5%	-5V ±5%	0°C to +70°C
Am2802DM, Am2803HM, Am2804HM	5V ±5%	-5V ±5%	-55°C to +125°C

ELECTRICAL CHARACTERISTICS over operating range

Parameters	Description	Test Conditions	Am1402A, 3A, 4A			Am2802, 3, 4			Units	
			Min.	Typ.	Max.	Min.	Typ.	Max.		
V_{IH}	Input HIGH Voltage		$V_{CC}-2.0$			$V_{CC}-2.0$			V	
V_{IL}	Input LOW Voltage		$V_{CC}-10$		$V_{CC}-4.2$	$V_{CC}-10$		$V_{CC}-4.2$	V	
I_I	Input Current	$T_A = 25^\circ\text{C}$		<10	500		<10	500	nA	
I_O	Output Leakage Current	$T_A = 25^\circ\text{C}, V_{OUT} = 0\text{V}$		<10	1000		<10	1000	nA	
$I_{\phi L}$	Clock Leakage Current	$T_A = 25^\circ\text{C}, V_{\phi} = -12\text{V}$		10	1000		10	1000	nA	
V_{OH}	Output HIGH Voltage Driving TTL	$R_L = 3\text{k to } V_{DD}, V_{DD} = -5\text{V} \pm 5\%$	2.4	3.5		$V_{CC}-1.9$	$V_{CC}-1$		V	
	Output HIGH Voltage Driving MOS	$R_L = 4.7\text{k to } V_{DD}, V_{DD} = -5\text{V} \pm 5\%$	$V_{CC}-1.9$	$V_{CC}-1$		$V_{CC}-1.9$	$V_{CC}-1$			
	Output HIGH Voltage Driving TTL	$R_L = 4.7\text{k to } V_{DD}, V_{DD} = -9\text{V} \pm 5\%$	2.4	3.5						
	Output HIGH Voltage Driving MOS	$R_L = 6.2\text{k to } V_{DD}, 3.9\text{k to } V_{CC}, V_{DD} = -9\text{V} \pm 5\%$	$V_{CC}-1.9$	$V_{CC}-1$						
V_{OL}	Output LOW Voltage	$V_{DD} = -5\text{V} \pm 5\%, R_L = 3\text{k to } V_{DD}, I_{OL} = -1.6\text{mA}$		-0.3	0.5		-0.3	0.5	V	
		$R_L = 4.7\text{k to } V_{DD}, V_{DD} = -9\text{V} \pm 5\%, I_{OL} = -1.6\text{mA}$		-0.3	0.5					
$V_{\phi H}$	Clock Input HIGH Level		$V_{CC}-1$		$V_{CC}+0.3$	$V_{CC}-1$		$V_{CC}+0.3$	V	
$V_{\phi L}$	Clock Input LOW Level	$V_{DD} = -5\text{V} \pm 5\%$	$V_{CC}-15$		$V_{CC}-17$	$V_{CC}-15$		$V_{CC}-17$	V	
		$V_{DD} = -9\text{V} \pm 5\%$	$V_{CC}-12.6$		$V_{CC}-14.7$	$V_{CC}-12.6$		$V_{CC}-14.7$		
$I_{DD(-5)}$ (Note 1)	V_{DD} Current, $V_{DD} = -5\text{V} \pm 5\%$	5 MHz Data Rate 33% Duty Cycle $V_{\phi L} = V_{CC}-17\text{V}$	$T_A = 25^\circ\text{C}$		40	50		40	50	mA
			$T_A = 0^\circ\text{C}$					56		
			$T_A = -55^\circ\text{C}$						70	
	V_{DD} Current, $V_{DD} = -5\text{V} \pm 5\%$	10 MHz Data Rate 40% Duty Cycle $V_{\phi L} = V_{CC}-17\text{V}$	$T_A = 25^\circ\text{C}$					50	60	mA
			$T_A = 0^\circ\text{C}$						68	
			$T_A = -55^\circ\text{C}$						80	
$I_{DD(-9)}$ (Note 1)	V_{DD} Current, $V_{DD} = -9\text{V} \pm 5\%$	3 MHz Data Rate 26% Duty Cycle $V_{\phi L} = V_{CC}-14.7\text{V}$	$T_A = 25^\circ\text{C}$		30	40		30	40	mA
			$T_A = 0^\circ\text{C}$					45		
			$T_A = -55^\circ\text{C}$						60	

Note: 1. Power dissipation is directly proportional to clock duty cycle and independent of frequency. The duty cycle is the clock LOW time (one clock line) divided by the clock period. At $V_{DD} = -9\text{V}$ the maximum duty cycle is 26%. The duty cycle should be kept as small as possible to minimize power dissipation.

SWITCHING CHARACTERISTICS AND OPERATING CONDITIONS (Over Operating Range)

Am1402A/Am1403A/Am1404A

 $V_{DD} = -5 V \pm 5\%$
(Test Load 1) $V_{DD} = -9 V \pm 5\%$
(Test Load 2)

Parameter	Description	Test Conditions	Min.			Max.			Units
			Min.	Typ.	Max.	Min.	Typ.	Max.	
f_c	Clock Frequency Range		(Note 1)		2.5	(Note 1)		1.5	MHz
f_d	Data Repetition Rate		(Note 1)		5.0	(Note 1)		3.0	MHz
$t_{\phi PW}$	Clock Pulse Width		0.13		10	0.17		10	μs
$t_{\phi d}$	Clock Pulse Delay (Note 2)	$t_{\phi PW} = 130 ns$	10		(Note 2)	10		(Note 2)	ns
t_f, t_r	Clock Pulse Rise/Fall Time				1000			1000	ns
t_s	Data Set Up Time	$t_r = t_f \leq 50 ns$	30			60			ns
t_h	Data Hold Time	$t_r = t_f \leq 50 ns$	20			20			ns
t_{pd+}, t_{pd-}	Clock to Data Out Delay				90			110	ns
C_{IN}^*	Input Capacitance	@ 1 MHz, 250 mVPP		5	10		5	10	pF
C_{OUT}^*	Output Capacitance	@ 1 MHz, 250 mVPP		5	10		5	10	pF
C_{ϕ}^*	Clock Capacitance	@ 1 MHz, 250 mVPP		110	140		110	140	pF

SWITCHING CHARACTERISTICS AND OPERATING CONDITIONS (Over Operating Range)

Am2802/Am2803/Am2804

Clock Pulse Width = 70nsec
Clock LOW Level = (V_{CC}-15) $V_{DD} = -5 V \pm 5\%$
(Test Load 1)

Parameter	Description	Test Conditions	Min.			Max.			Units
			Min.	Typ.	Max.	Min.	Typ.	Max.	
f_c	Clock Frequency Range	$t_r = t_f = 10 ns$		(Note 1)		5.0 (Note 4)			MHz
f_d	Data Repetition Rate (Note 1)			(Note 3)		10.0 (Note 4)			MHz
$t_{\phi PW}$	Clock Pulse Width			0.07		10			μs
$t_{\phi d}$	Clock Pulse Delay	$t_{\phi PW} = 70 ns$		10		(Note 2)			ns
t_f, t_r	Clock Pulse Rise/Fall Time					1000			ns
t_s	Data Set Up Time			30					ns
t_h	Data Hold Time			20					ns
t_{pd+}, t_{pd-}	Clock to Data Out Delay					90			ns

Notes:

- See minimum operating frequency graph for low limits on data rep. rate.
- Upper limit on $t_{\phi d}$ is determined by minimum frequency.
- See max clock pulse delay graph for guarantee.
- For additional information on 10MHz operation (5MHz clock rate) see AMD application note dated July 1973 on "Applications of Dynamic Shift Registers."

DESCRIPTION OF TERMS

OPERATIONAL TERMS

- V_{OH} Minimum logic HIGH output voltage with output HIGH current flowing out of output.
- V_{OL} Maximum logic LOW output voltage with output LOW current into junction of output and load resistor.
- V_{IH} Logic HIGH input voltage.
- V_{IL} Logic LOW input voltage.
- I_{OL} Clock LOW input voltage.
- I_{OH} Clock HIGH input voltage.
- I_I Input leakage current.
- I_O Output leakage current.
- I_{DD} Power supply current.
- C_{IN} Input capacitance.
- C_{ϕ} Input clock capacitance.
- C_{OUT} Output capacitance.

FUNCTIONAL TERMS

- ϕ_1, ϕ_2 The two clock phases required by the dynamic shift register.
- f The clock frequency of the shift register.
- r The input data repetition rate.

SWITCHING TERMS

- $t_{\phi d}$ The delay between the LOW to HIGH transition of a clock phase to the HIGH to LOW transition of the other clock phase.
- $t_{\phi PW}$ The clock pulse widths necessary for correct operation.
- t_r, t_f The clock pulse rise and fall times necessary for correct operation.
- t_s The time required for the input data to be present prior to the LOW to HIGH transition of the clock phase to ensure correct operation.
- t_h The time required for the input data to remain present after the LOW to HIGH transition of the clock phase to ensure correct operation.
- t_{pd+} The propagation delay from the HIGH to LOW clock phase ϕ_1 transition to the output LOW to HIGH transition.
- t_{pd-} The propagation delay from the HIGH to LOW clock phase ϕ_2 transition to the output HIGH to LOW transition.

SWITCHING WAVEFORMS

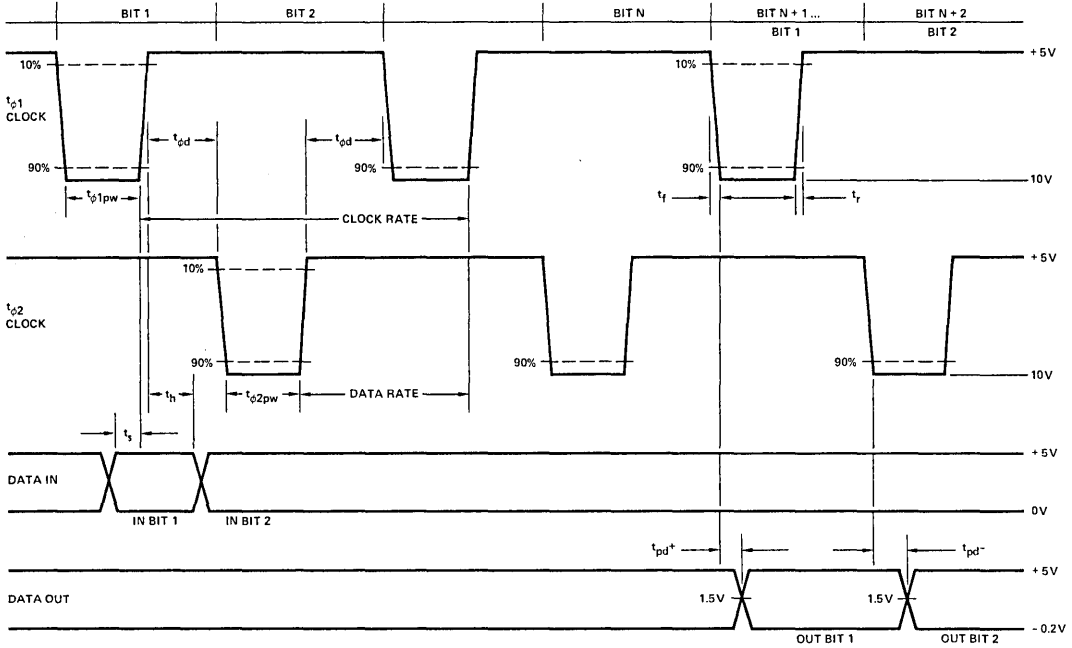

Clock Rise Time 10 ns
 Clock Fall Time 10 ns
 Output Load 1 TTL Load

Test Load 1

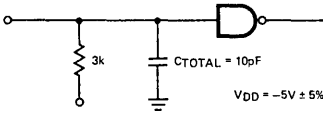

Test Load 2

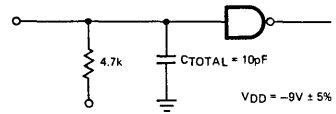

MOS-398

CIRCUIT DIAGRAM

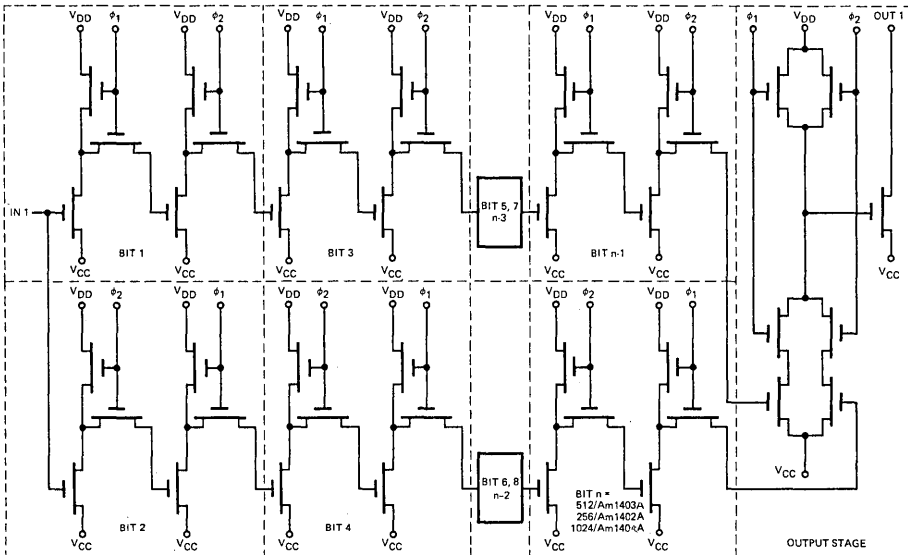

MOS-399

POWER CHARACTERISTICS

Minimum Operating Data Rate or Maximum Clock Pulse Delay Versus Temperature (For Small Duty Cycles)

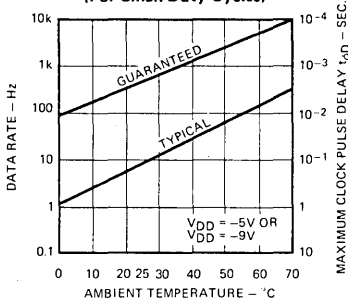

IOH Versus VOH

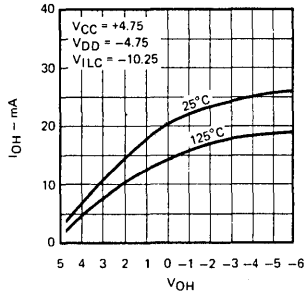

Typical Range of tpd+ Versus Temperature

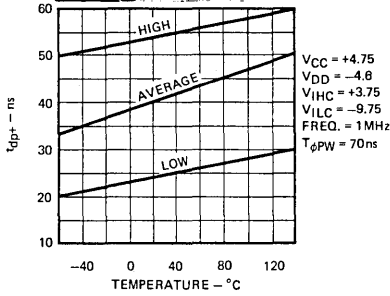

IDD Versus Clock Duty Cycle

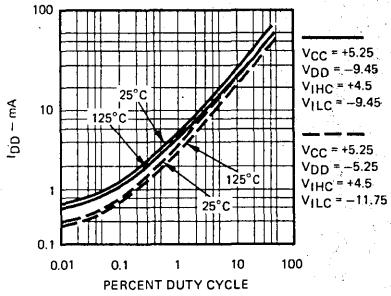

5

MOS-400

ORDERING INFORMATION

Am2802/Am1402A

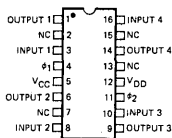

Am2803/Am1403A

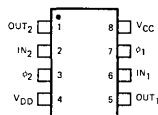

Am2804/Am1404A

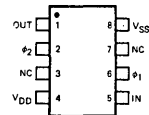

Am2803/Am1403A

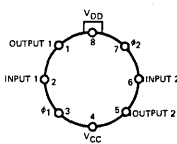

Am2804/Am1404A

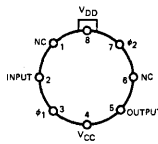

MOS-401

APPLICATIONS

256-Bit Delay
Write Recirculate Logic

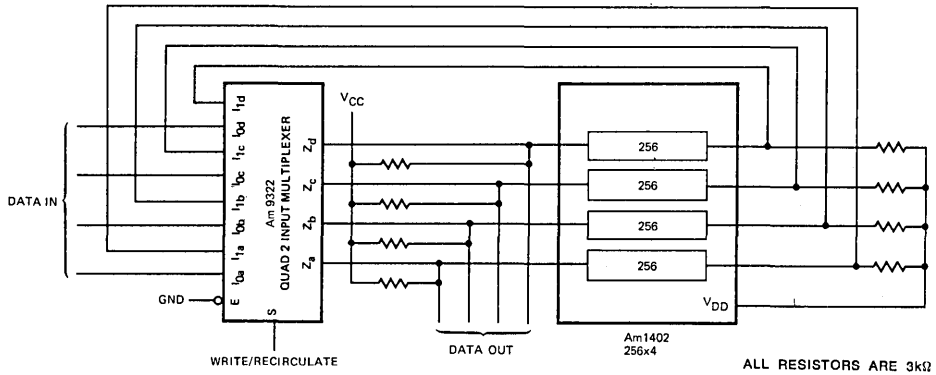

DTL/TTL To MOS To DTL/TTL Interface

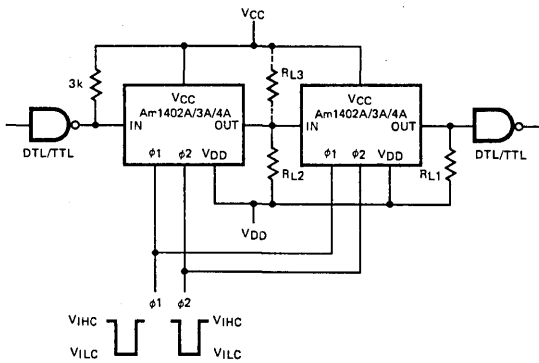

RL Load Resistor Values
for Different VDD Supplies

	V _{CC} = 5 V V _{DD} = -5 V	V _{CC} = 5 V V _{DD} = -9 V
R _{L1}	3.0 k	4.7 k
R _{L2}	4.7 k	6.2 k
R _{L3}	Not required	3.9 k

MOS-402

PAD	1402A/2802		1403A/2803		1404A/2804	
	PIN	SIGNAL	PIN	SIGNAL	PIN	SIGNAL
1	1	OUT 1	2	IN 1	2	IN
2	3	IN 1	3	φ 1	3	φ 1
3	4	φ 1	4	V _{CC}	4	V _{CC}
4	5	V _{CC}	5	OUT 2	5	OUT
5	6	OUT 2	6	IN 2	7	φ 2
6	8	IN 2	7	φ 2	8	V _{DD}
7	9	OUT 3	8	V _{DD}	8	V _{DD}
8	10	IN 3	1	OUT 1		
9	11	φ 2				
10	12	V _{DD}				
11	14	OUT 4				
12	16	IN 4				

Metallization and Pad Layout

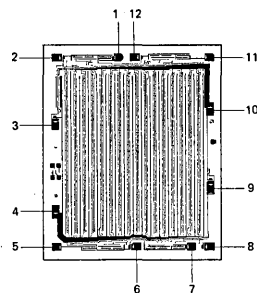

DIE SIZE .109" X .131"