

NIXIE® NUMERICAL INDICATOR TUBE

TYPES
B-5750
B-5750S

The B-5750 NIXIE tube is an ultra-long life, high quality, cold-cathode indicator tube having a common anode. It can display the numerals 0-9 and has two decimal points inside the tube (right and left of the numerals) which are independently operable. The numeral aspect ratio (height to width) has been designed to provide the optimum in readability and viewing distance. The small diameter of the tube (0.530" max) permits 0.540" center-to-center mounting and its short seated height (1.500" max including standoff) allows for minimal instrument panel dimensions.

A moveable pin-straightener-standoff, which is used to align the tube pins for ease of PC layout and insertion, is part of the tube assembly. The standoff also allows solder gas to escape during soldering. These tubes have been specifically designed to operate both in normal DC applications and strobed/time sharing applications (See Note 8).

The B-5750S is identical to the B-5750 except its leads are cut to 0.175" ± .015 for use with the SK-207 socket, Bulletin 1138.

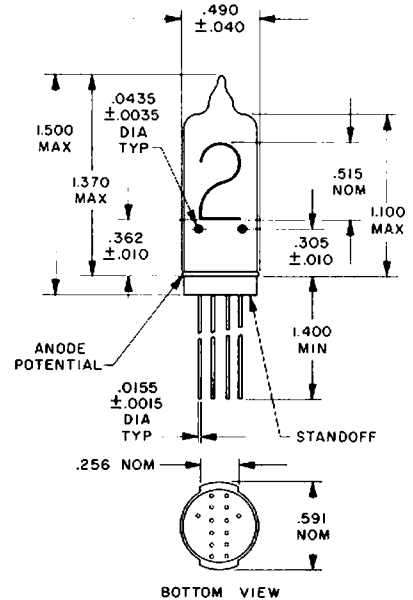
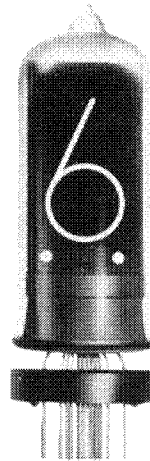

Figure 1. OUTLINE DRAWING
(NOTE 11)

ELECTRICAL SPECIFICATIONS

Absolute Ratings

Ionization Voltage (Note 1, Fig. 5)	+170 Vdc max
Supply Voltage	+170 Vdc min
Numeral Cathode Current (Note 5)	3.8 ma max
Peak Anode Current	
(Notes 8 & 9)	15 ma max
Decimal Point Cathode Current	
(Note 6)	0.1 ma to 0.3 ma
Cathode Pre-bias	+60 Vdc to +120 Vdc

Typical Operating Conditions (Notes 1, 2 & 7, Figures 5 & 6)

Supply Voltage	+170 Vdc
Series Resistor (Table 2)	9.1 kΩ
Anode Current (Figure 5)	2.6 ma typ
Decimal Point Current (Table 2)	0.2 ma typ
Cathode Pre-bias Voltage	+60 Vdc

Test Conditions (Figures 5 and 6)

Test Limits (Figures 5 and 6)

MECHANICAL CHARACTERISTICS

Outline Drawing	Figure 1
Pin Connection	Table 1
Pin Layout	Figure 2
PC Layouts	Figure 3
Weight	0.4 oz. max
Lead Finish	Hot tin dip from 0.150 in. from tube base
Max. Viewing Distance	24 feet

Mounting	Note 3
Color	Neon red
	3650, 4358, 5654 & 5852 angstroms
Basing Diagram	Figure 4
Brightness	200 ft. lamberts
Soldering Heat	260 ± 5°C for 10 ± 1 sec.
	0.150" from tube base

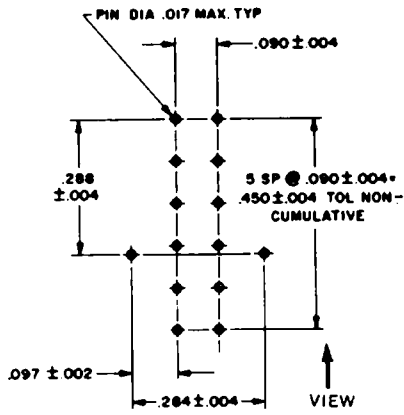

Figure 2. PIN LAYOUT (TOP VIEW)

PIN	CONNECTIONS
1	NUMERAL 1
2	NUMERAL 2
3	NUMERAL 3
4	NUMERAL 4
5	NUMERAL 5
6	NUMERAL 6
7	ANODE *
8	NUMERAL 7
9	NUMERAL 8
10	ANODE *
11	NUMERAL 9
12	NUMERAL 0
13	RT DEC PT
14	LFT DEC PT

*Anode pins are connected internally

Table 1. PIN CONNECTIONS

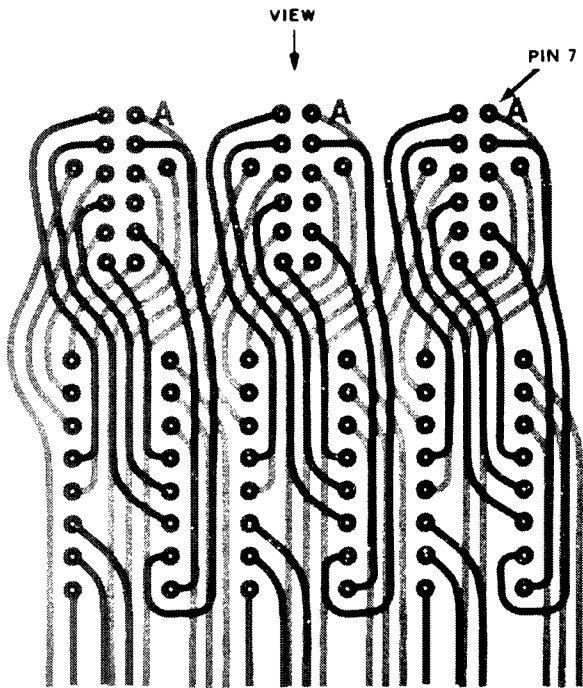

Figure 3a. P.C. LAYOUT WITH FAIRCHILD 9960 (TOP VIEW)
(9960 notch away from viewer)

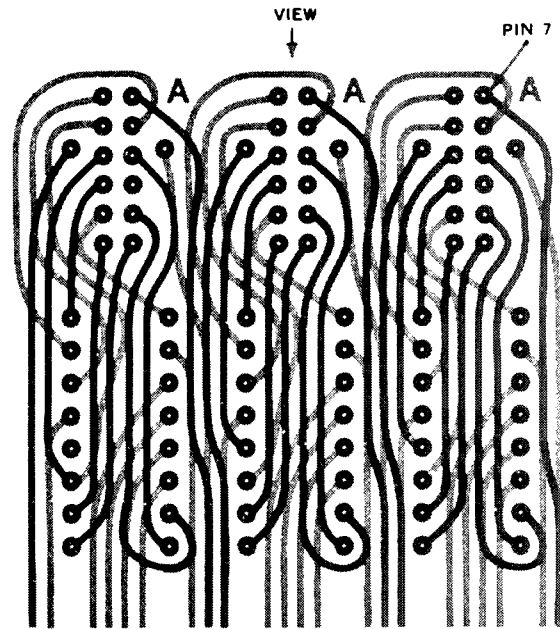

Figure 3b. P.C. LAYOUT WITH TEXAS INSTRUMENTS SN-7441N (TOP VIEW)

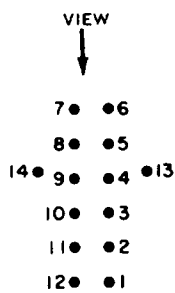
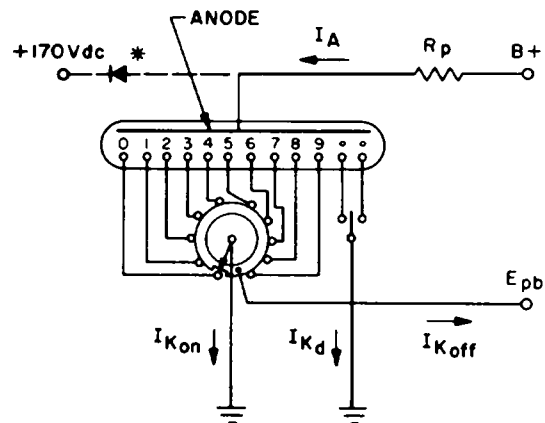

Figure 4. BASING DIAGRAM (BOTTOM VIEW)



* To test for Ionization at +170 Vdc

Figure 5. TEST CIRCUIT

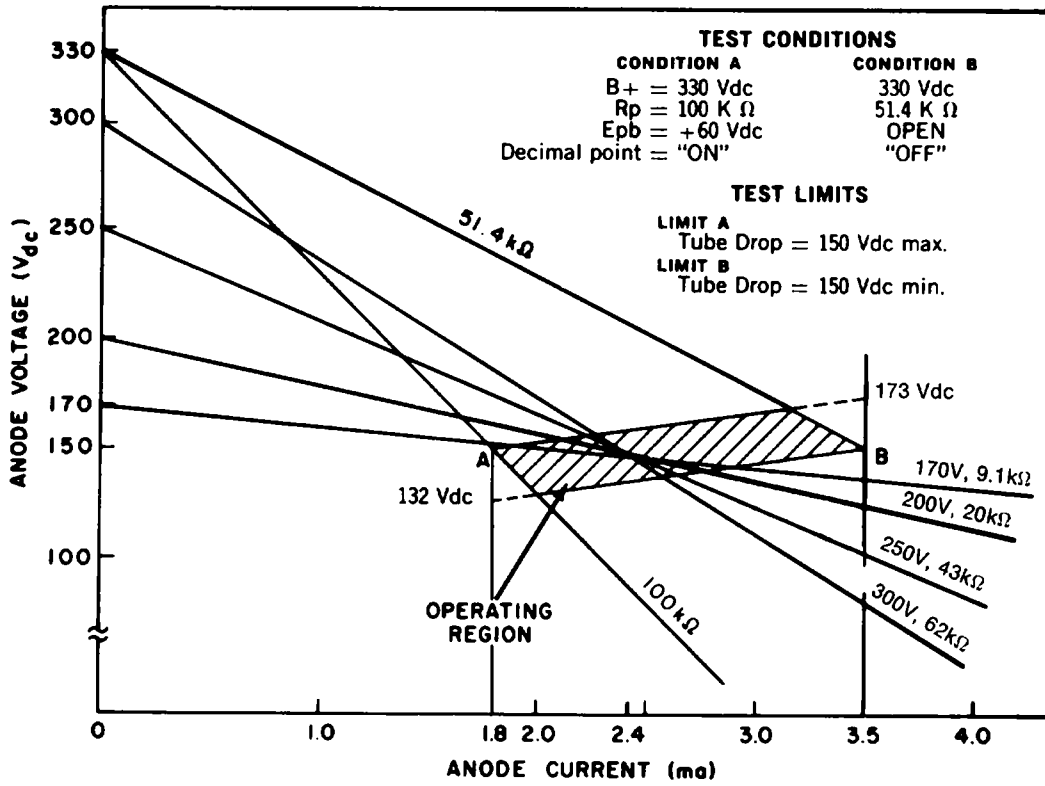

Figure 6. TUBE CHARACTERISTICS (NOTE 7)

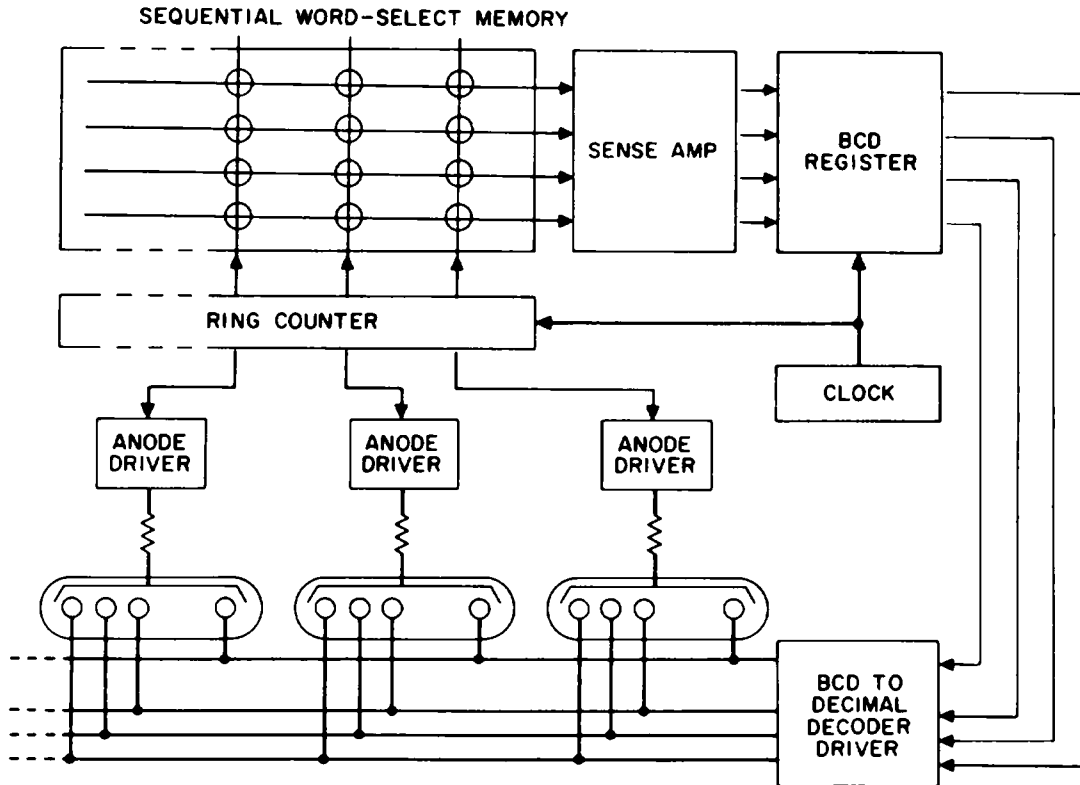

Figure 7. BLOCK DIAGRAM
TYPICAL TIME SHARING APPLICATION (NOTE 8)