

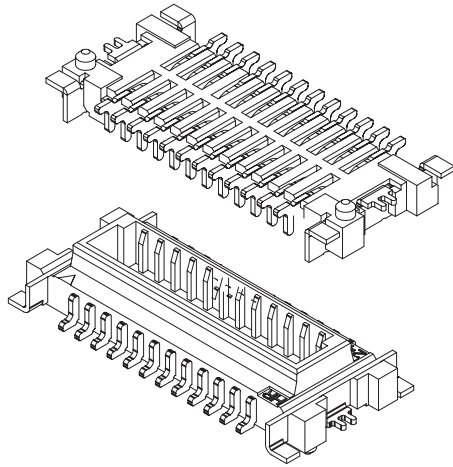

Specifications

- Current rating: 0.5A AC,DC
- Voltage rating: 50V AC,DC
- Temperature range: -25°C ~ +85°C
- Contact resistance: 30mΩ Max.
- Insulation resistance: 100MΩ Min.
- Withstanding voltage: 250V AC/minute
- *Contact H.R for details*



Assembly layout

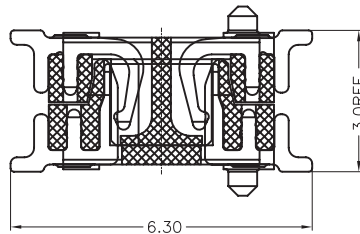

Ordering code

① B0802 ② HF ③ SF ④ 2X ⑤ 12P

- ① Series No.
- ② Connector type: HF=Female
- ③ Mounting type: SF=SMT with boss
- ④ 2X=Dual row
- ⑤ No. of circuits

① B0802 ② HM ③ SF ④ 2X ⑤ 12P

- ① Series No.
- ② Connector type: HM=Male
- ③ Mounting type: SF=SMT with boss
- ④ 2X=Dual row
- ⑤ No. of circuits



B0802 SERIES

0.80mm pitch board to board connector

B0802HF-SF

0.80mm pitch board to board connector SMT

Reference Informations:

- *Material: Pin: Phosphor Bronze/Gold-flash
Solder Tabs: Brass/Matte Tin-Plated
Housing: LCP,UL94V-0
- *Mates with H.R B0802HM serie Housing

	B0802HF-SF-2XNP						
	N	L	X	G1	T	00	L
	①	②	③	④	⑤	⑥	⑦
	① N=Halogen Free						
	② Material: L=LCP						
	③ Color: N=Natural; B=Black						
	④ Plating code for contacts: G1=Gold-flash						
⑤ Plating code for forklock: T=Matte Tin-plated							
⑥ Option code: 00=Standard							
⑦ Packing code: L=Tape & Reel(With Mylar)							

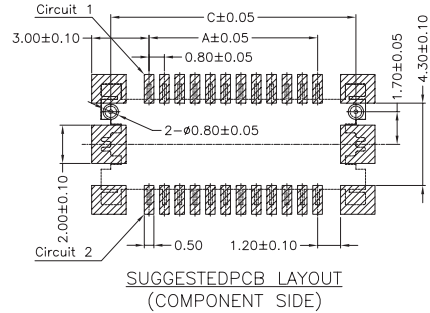
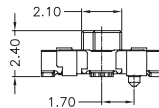
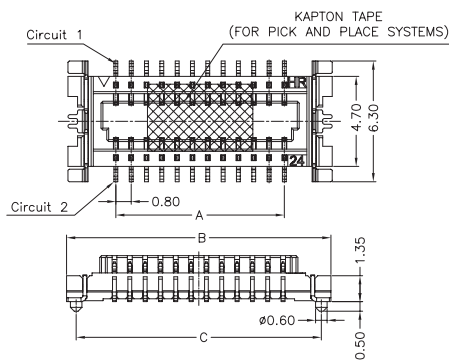
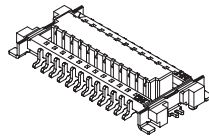

Ordering Information & Dimensions:

PART NO.	Dimensions		
	A	B	C
B0802HF-SF-2X05P	3.20	8.20	7.20
B0802HF-SF-2X06P	4.00	9.00	8.00
B0802HF-SF-2X07P	4.80	9.80	8.80
B0802HF-SF-2X08P	5.60	10.60	9.60
B0802HF-SF-2X10P	7.20	12.20	11.20
B0802HF-SF-2X12P	8.00	13.80	12.80
B0802HF-SF-2X13P	9.60	14.60	13.60
B0802HF-SF-2X15P	11.20	16.20	15.20
B0802HF-SF-2X17P	12.80	17.80	16.80
B0802HF-SF-2X18P	13.60	18.60	17.60
B0802HF-SF-2X20P	15.20	20.20	19.20
B0802HF-SF-2X25P	19.20	24.20	23.20
B0802HF-SF-2X30P	23.20	28.20	27.20
B0802HF-SF-2X40P	31.20	36.20	35.20

Unit:mm

A
B
C
F
ST
HRJ
DC

B0802HM-SF

0.80mm pitch board to board connector SMT

Reference Informations:

- *Material: Pin: Phosphor Bronze/Gold-flash
Solder Tabs: Brass/Matte Tin-Plated
Housing: LCP,UL94V-0
- *Mates with H.R B0802HF serie Housing

	B0802HM-SF-2XNP						
	N	L	X	G1	T	00	L
	①	②	③	④	⑤	⑥	⑦
	① N=Halogen Free						
	② Material: L=LCP						
	③ Color: N=Natural; B=Black						
	④ Plating code for contacts: G1=Gold-flash						
⑤ Plating code for forklock: T=Matte Tin-plated							
⑥ Option code: 00=Standard							
⑦ Packing code: L=Tape & Reel(With Cap)							

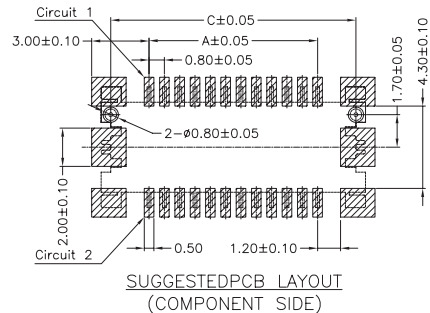
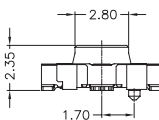
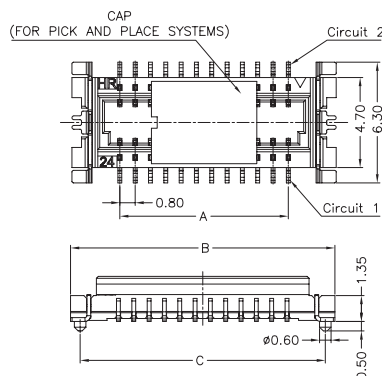
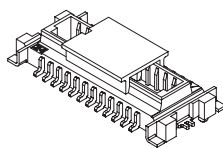

Ordering Information & Dimensions:

PART NO.	Dimensions		
	A	B	C
B0802HM-SF-2X05P	3.20	8.20	7.20
B0802HM-SF-2X06P	4.00	9.00	8.00
B0802HM-SF-2X07P	4.80	9.80	8.80
B0802HM-SF-2X08P	5.60	10.60	9.60
B0802HM-SF-2X10P	7.20	12.20	11.20
B0802HM-SF-2X12P	8.00	13.80	12.80
B0802HM-SF-2X13P	9.60	14.60	13.60
B0802HM-SF-2X15P	11.20	16.20	15.20
B0802HM-SF-2X17P	12.80	17.80	16.80
B0802HM-SF-2X18P	13.60	18.60	17.60
B0802HM-SF-2X20P	15.20	20.20	19.20
B0802HM-SF-2X25P	19.20	24.20	23.20
B0802HM-SF-2X30P	23.20	28.20	27.20
B0802HM-SF-2X40P	31.20	36.20	35.20

Unit:mm