

Planar Transformer

For Maxim MAX5069A
PWM Controller

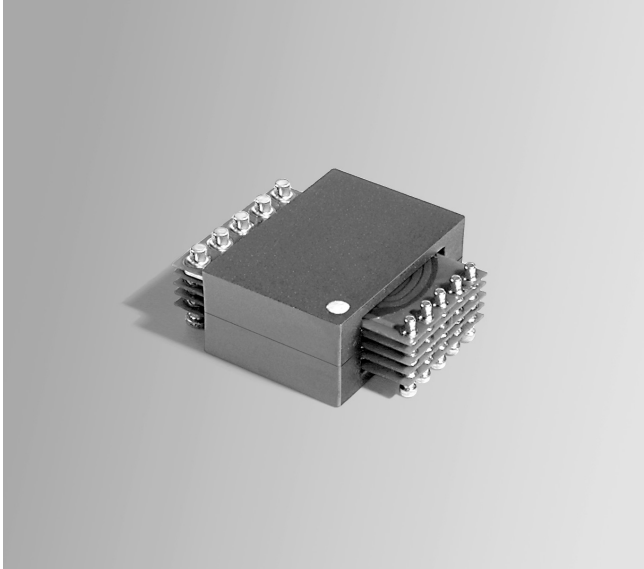

The B0860-C is approved by Maxim for use with their MAX5069A high-frequency, current-mode, pulse-width modulation (PWM) controller.

This planar transformer can be used in push-pull, half-bridge and full-bridge topologies. It is ideal for use in high-current, isolated or nonisolated power supply applications. It offers high efficiency in a low-profile package and features split primary and secondary windings, a separate auxiliary winding and 1500 Vdc primary to secondary isolation.

Coilcraft's **Planar Prototyping Kit C356** was used to design this transformer. No tooling or additional parts were required. To order the kit, contact Coilcraft or purchase on-line at <http://order.coilcraft.com>.

Free evaluation samples of B0860-C are available by contacting Coilcraft or by visiting www.coilcraft.com.

Part number ¹	Output power (W)	Input voltage range (V)	Output voltage nom (V)	Output current (A peak)	Primary inductance ² min (μ H)	Leakage inductance ³ max (μ H)	DCR max (mOhms)	Turns ratio ⁴	
								pri:sec	pri:aux
B0860-CL_	180	36 – 72	12	15	187.0	0.25	Pri: 38.0 Sec: 4.0 Aux: 120.0	10:4	10:3

1. When ordering, specify a **packaging** code:

B0860-CLD

Packaging: D = 13" machine ready reel. EIA-481 embossed plastic tape (200per full reel).

B = Less than full reel. In tape, but not machine ready. To have a leader and trailer added (\$25 charge), use code letter D instead.

2. Inductance measured on an Agilent/HP 4284 between pins 2 and 4 at 250 kHz, 0.1 Vrms, 0 Adc.

3. Leakage inductance measured between pins 2 and 4 at 250 kHz, 0.1 Vrms, 0 Adc with pins 6, 8 and 10 shorted.

4. Turns ratio is with the primary windings and secondary windings connected in series.

5. Storage and ambient operating temperature range: -40°C to $+85^{\circ}\text{C}$.

6. Electrical specifications at 25°C .

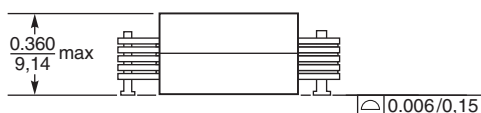
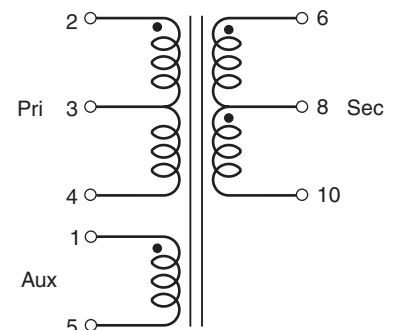
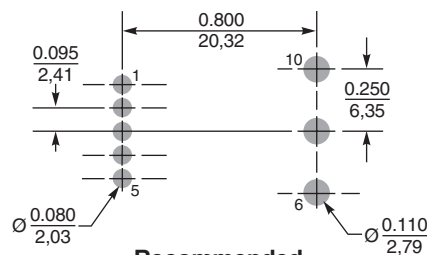
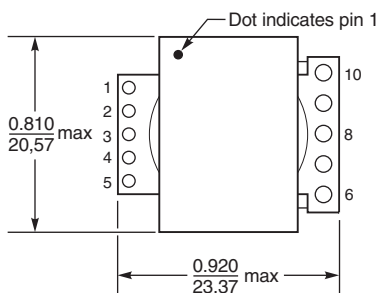

Weight: 11.8 g
Terminations: Matte tin over nickel over brass
Tape and reel: 200/13" reel 44 mm tape width