



# Product Specification

AU OPTRONICS CORPORATION

- ( V ) Preliminary Specifications
- ( ) Final Specifications

<b>Module</b>	<b>10.1" WUXGA 16:10 Color TFT-LCD with LED Backlight design</b>
<b>Model Name</b>	<b>B101UAN01.7_H/W 1A</b>
<b>Note</b>	<i>LED Backlight with driving circuit design</i>

<b>Customer</b>	<b>Date</b>
<b>Checked &amp; Approved by</b>	<b>Date</b>
<p>Note: This Specification is subject to change without notice.</p>	

<b>Approved by</b>	<b>Date</b>
Trista Chiang	2013/06/07
<b>Prepared by</b>	
Erica YT Lin	2013/06/07
<p><b>MPBU Marketing Division</b> <b>AU Optronics corporation</b></p>	



## Contents

<b>1. Handling Precautions</b> .....	<b>5</b>
<b>2. General Description</b> .....	<b>6</b>
2.1 General Specification.....	6
2.2 Optical Characteristics.....	7
<b>3. Functional Block Diagram</b> .....	<b>12</b>
<b>4. Absolute Maximum Ratings</b> .....	<b>13</b>
4.1 Absolute Ratings of TFT LCD Module .....	13
4.2 Absolute Ratings of Environment.....	13
<b>5. Electrical Characteristics</b> .....	<b>14</b>
5.1 TFT LCD Module .....	14
5.2 Backlight Unit.....	21
<b>6. Signal Interface Characteristic</b> .....	<b>23</b>
6.1 Pixel Format Image.....	23
6.2 The Input Data Format.....	24
6.3 Integration Interface Requirement .....	25
6.4 MIPI Interface Timing.....	27
6.5 Power ON/OFF Sequence .....	28
<b>7. Panel Reliability Test</b> .....	<b>29</b>
7.1 Vibration Test.....	29
7.2 Shock Test .....	29
7.3 Reliability Test.....	29
<b>8. Mechanical Characteristics</b> .....	<b>30</b>
8.1 LCM Outline Dimension.....	30
<b>9. Shipping and Package</b> .....	<b>32</b>
9.1 Shipping Label Format.....	32
9.2 Carton Package .....	32
9.3 Shipping Package of Palletizing Sequence .....	32
<b>10. Appendix</b> .....	<b>32</b>
10.1 EDID Description .....	32



# Product Specification

AU OPTRONICS CORPORATION

## Record of Revision

Version and Date	Page	Old description	New Description	Remark	
0.1_2013/01/24	All	First Edition for Customer			
0.2_2013/01/29	5		Display Mode: AHVA		
	12	LCD drive voltage 4.0V max	LCD drive voltage 4.5Vmax		
	13	IDD 320mA VDD 3.3V typ. & 3.6V max	IDD 316mA VDD 3.7V typ. & 4.2V max		
	25		Add 3V~4.2V in pin 1 & pin2 description and update pin assignment name (pin10~23)		
0.3_2013/03/11	29		Update 2D drawing		
	33~35		Add EDID		
0.4_2013/3/27	6		Update Temperature Range		
	28		Update RA test Item		
0.5_2013/04/08	20	LED Life time 15,000hrs	LED Life time 12,000hrs		
0.6_2013/04/26	5	1.5 max. (13 points)	1.53 max.(13 points)		
			Add efficiency condition		
		Thickness 5.35	2.45 (Panel side) 5.35 (PCBA side)		
	6	Luminance Uniformity (13P) 1.67	Luminance Uniformity (13P) 1.53		
			Update Chromaticity		
			CR=10	CR ≥ 10	
		20		Update Note 2	
	25		Pin assignment (Pin 28)		
	28	Thermal Shock Test 24 cycle	27 cycle		



# Product Specification

AU OPTRONICS CORPORATION

0.7 2013/05/02	5&6	Luminance Uniformity (13P) 1.53	Luminance Uniformity (13P) 1.42	
	12	Operating Temperature 50°C	Operating Temperature 60°C	
			Delete curve	
	20		Update condition description	
0.8 2013/06/07	34~36		Update EDID	

## 1. Handling Precautions

- 1) Since front polarizer is easily damaged, pay attention not to scratch it.
- 2) Be sure to turn off power supply when inserting or disconnecting from input connector.
- 3) Wipe off water drop immediately. Long contact with water may cause discoloration or spots.
- 4) When the panel surface is soiled, wipe it with absorbent cotton or other soft cloth.
- 5) Since the panel is made of glass, it may break or crack if dropped or bumped on hard surface.
- 6) Since CMOS LSI is used in this module, take care of static electricity and insure human earth when handling.
- 7) Do not open nor modify the Module Assembly.
- 8) Do not press the reflector sheet at the back of the module to any directions.
- 9) At the insertion or removal of the Signal Interface Connector, be sure not to rotate nor tilt the Interface Connector of the TFT Module.
- 11) After installation of the TFT Module into an enclosure (Notebook PC Bezel, for example), do not twist nor bend the TFT Module even momentary. At designing the enclosure, it should be taken into consideration that no bending/twisting forces are applied to the TFT Module from outside. Otherwise the TFT Module may be damaged.
- 12) Small amount of materials having no flammability grade is used in the LCD module. The LCD module should be supplied by power complied with requirements of Limited Power Source (IEC60950 or UL1950), or be applied exemption.
- 13) Disconnecting power supply before handling LCD modules, it can prevent electric shock, DO NOT TOUCH the electrode parts, cables, connectors and LED circuit part of TFT module that a LED light bar build in as a light source of back light unit. It can prevent electrostatic breakdown.

## 2. General Description

B101UAN01.7 is a Color Active Matrix Liquid Crystal Display composed of a TFT LCD panel, a driver circuit, and LED backlight system. The screen format is intended to support the 16:10 WUXGA, 1920(H) x1200(V) screen and 16.7M colors (RGB 6-bits + Hi-FRC) with LED backlight driving circuit. All input signals are MIPI interface compatible.

B101UAN01.7 is designed for a display unit of notebook style personal computer and industrial machine.

## 2.1 General Specification

The following items are characteristics summary on the table at 25 °C condition:

Items	Unit	Specifications			
Screen Diagonal	[mm]	256.42 (10.1W")			
Active Area	[mm]	216.81 (H) x 135.50 (V)			
Pixels H x V		1920 x 3(RGB) x 1200			
Pixel Pitch	[mm]	0.113 X 0.113			
Pixel Format		R.G.B. Vertical Stripe			
Display Mode		Normally Black (AHVA mode)			
White Luminance	[cd/m <sup>2</sup> ]	380 typ, 323 min			
Luminance Uniformity		1.25 max. (5 points) 1.42 max (13 points)			
Contrast Ratio		800:1 typ., 600:1 min.			
Response Time	[ms]	25 Tpy / 35 Max			
Nominal Input Voltage VDD	[Volt]	+3.3 typ.			
Power Consumption (max)	[Watt]	3.45W (VLED 3V min with LED driver IC) ( Eff. 78% with duty 100%)			
Weight	[Grams]	140 max.			
Physical Size (panel only)	[mm]		Min.	Typ.	Max.
		Length	227.42	227.72	228.02
		Width	147.5	147.8	148.1
		Thickness	---	---	2.45 (Panel side) 5.35 (PCBA side)



# Product Specification

AU OPTRONICS CORPORATION

Electrical Interface		MIPI
Surface Treatment		Glare
Support Color		16.7M colors ( RGB 6-bit + Hi-FRC )
Temperature Range Operating Storage (Non-Operating)	[°C] [°C]	-20 to +60 -30 to +70
RoHS Compliance		RoHS Compliance

## 2.2 Optical Characteristics

The optical characteristics are measured under stable conditions at 25°C (Room Temperature) :

Item	Symbol	Conditions	Min.	Typ.	Max.	Unit	Note
White Luminance		5 points average	323	380	---	cd/m <sup>2</sup>	1, 4, 5.
Viewing Angle	$\theta_R$ $\theta_L$	Horizontal (Right) CR $\geq$ 10 (Left)	80 80	89 89	---	degree	4, 9
	$\psi_H$ $\psi_L$	Vertical (Upper) CR $\geq$ 10 (Lower)	80 80	89 89	---		
Luminance Uniformity	$\delta_{5P}$	5 Points	---	---	1.25		1, 3, 4
Luminance Uniformity	$\delta_{13P}$	13 Points	---	---	1.42		2, 3, 4
Contrast Ratio	CR		600	800	---		4, 6
Cross talk	%		---	---	4		4, 7
Response Time	$T_{RT}$	Rising + Falling	---	25	35	msec	4, 8
Color / Chromaticity Coordinates	Red	Rx	0.563	0.593	0.623	CIE 1931	4
		Ry	0.311	0.341	0.371		
	Green	Gx	0.294	0.324	0.354		
		Gy	0.559	0.589	0.619		
	Blue	Bx	0.124	0.154	0.184		
		By	0.093	0.123	0.153		
	White	Wx	0.283	0.313	0.343		
		Wy	0.299	0.329	0.359		
NTSC	%		-	52	-		

**Note 1:** 5 points position (Ref: Active area)

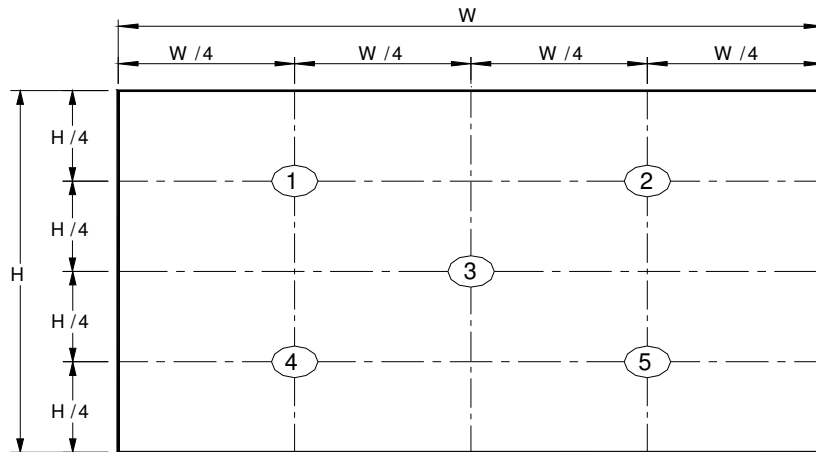

**Note 2:** 13 points position (Ref: Active area)

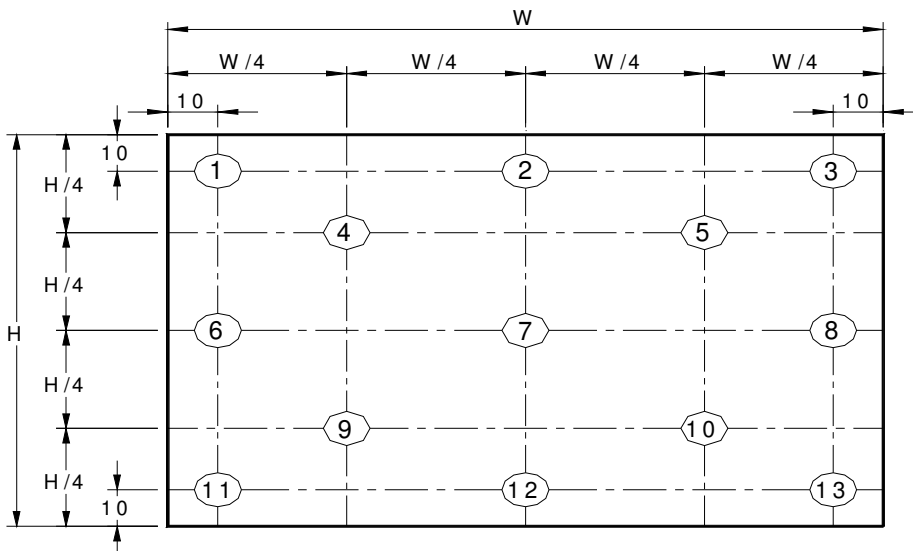

**Note 3:** The luminance uniformity of 5 or 13 points is defined by dividing the maximum luminance values by the minimum test point luminance

$$\delta_{w5} = \frac{\text{Maximum Brightness of five points}}{\text{Minimum Brightness of five points}}$$

$$\delta_{w13} = \frac{\text{Maximum Brightness of thirteen points}}{\text{Minimum Brightness of thirteen points}}$$



**Note 4:** Measurement method

The LCD module should be stabilized at given temperature for 30 minutes to avoid abrupt temperature change during measuring. In order to stabilize the luminance, the measurement should be executed after lighting Backlight for 30 minutes in a stable, windless and dark room, and it should be measured in the center of screen.

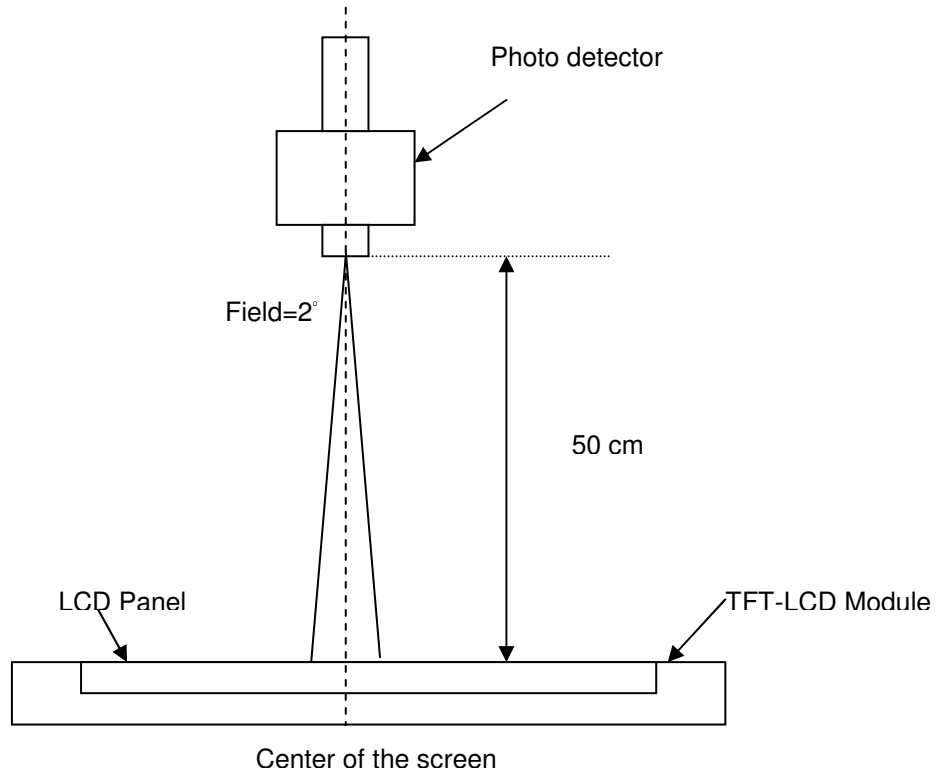

**Note 5 :** Definition of Average Luminance of White ( $Y_L$ ):

Measure the luminance of gray level 63 at 5 points ,  $Y_L = [L (1)+ L (2)+ L (3)+ L (4)+ L (5)] / 5$

$L (x)$  is corresponding to the luminance of the point X at Figure in Note (1).

**Note 6 :** Definition of contrast ratio:

Contrast ratio is calculated with the following formula.

$$\text{Contrast ratio (CR)} = \frac{\text{Brightness on the "White" state}}{\text{Brightness on the "Black" state}}$$

**Note 7 :** Definition of Cross Talk (CT)

$$CT = |Y_B - Y_A| / Y_A \times 100 (\%)$$

Where

$Y_A$  = Luminance of measured location without gray level 0 pattern ( $cd/m^2$ )

$Y_B$  = Luminance of measured location with gray level 0 pattern (cd/m<sup>2</sup>)

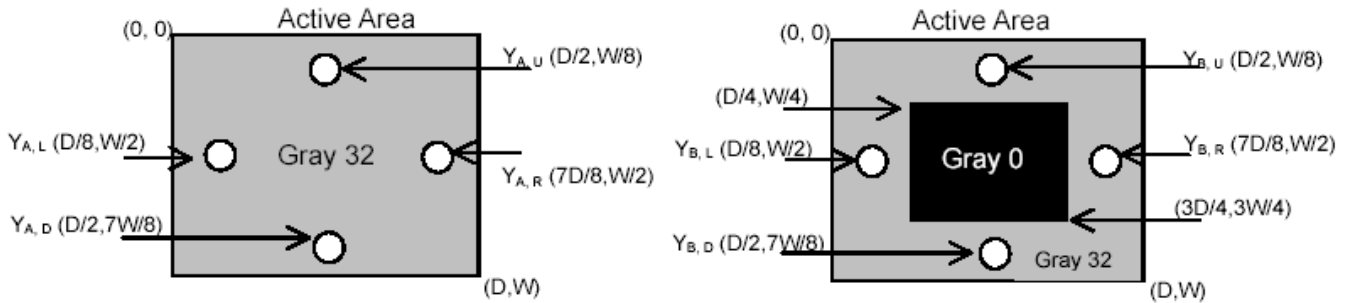

**Note 8:** Definition of response time:

The output signals of BM-7 or equivalent are measured when the input signals are changed from “Black” to “White” (falling time) and from “White” to “Black” (rising time), respectively. The response time interval between the 10% and 90% of amplitudes. Refer to figure as below.

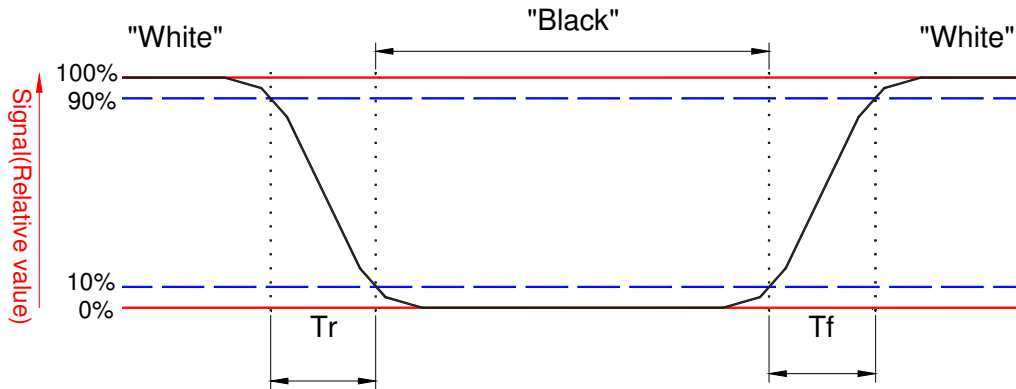

**Note 9.** Definition of viewing angle

Viewing angle is the measurement of contrast ratio  $\geq 10$ , at the screen center, over a  $180^\circ$  horizontal and  $180^\circ$  vertical range (off-normal viewing angles). The  $180^\circ$  viewing angle range is broken down as follows;  $90^\circ$  ( $\theta$ ) horizontal left and right and  $90^\circ$  ( $\Phi$ ) vertical, high (up) and low (down). The measurement direction is typically perpendicular to the display surface with the screen rotated about its center to develop the desired measurement viewing angle.

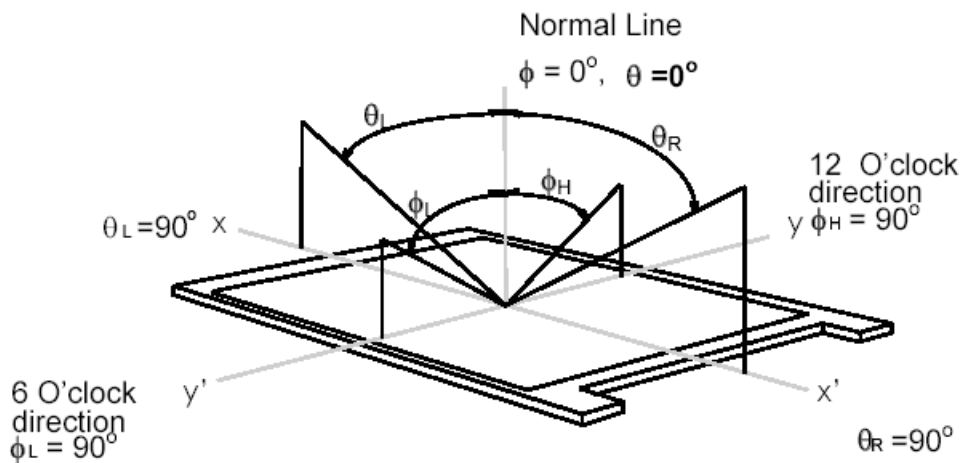

## 3. Functional Block Diagram

The following diagram shows the functional block of the 10.1 inches wide Color TFT/LCD 34 Pin one channel Module

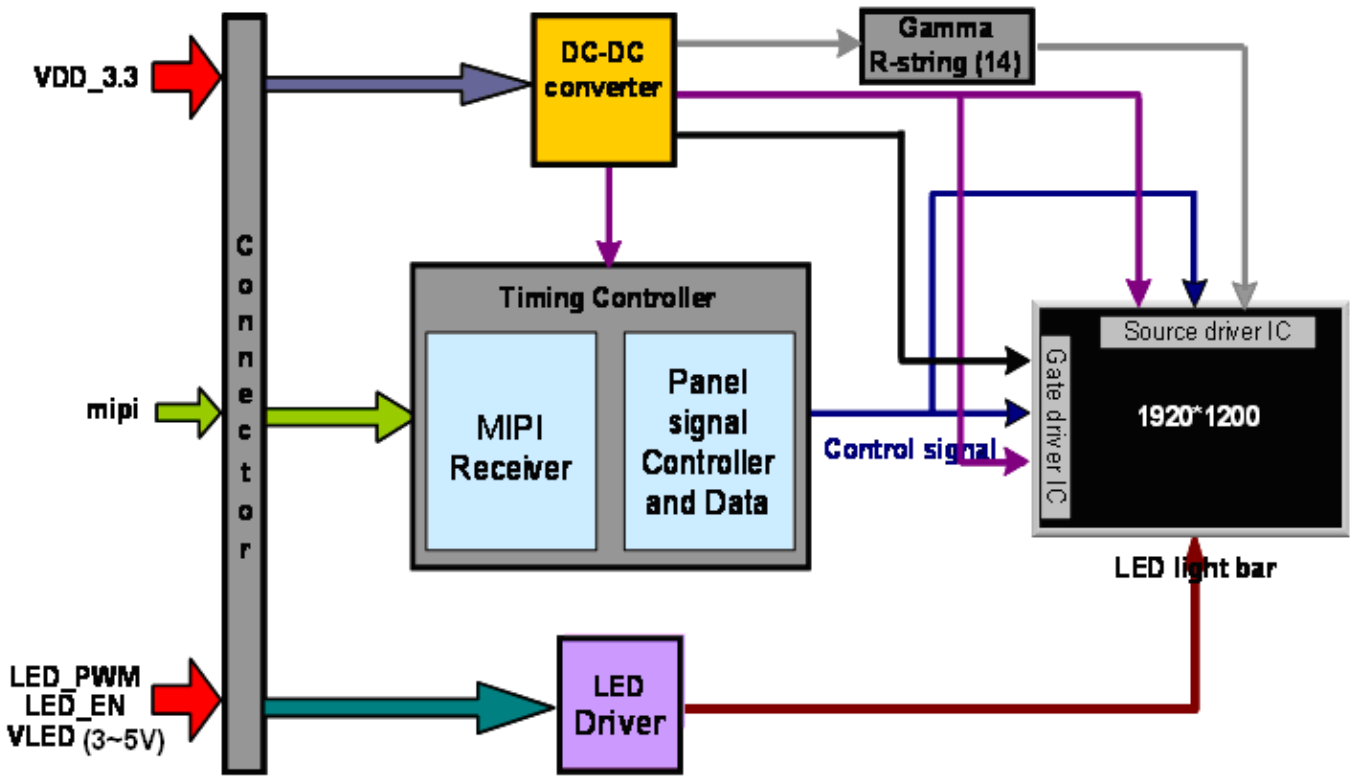



## 4. Absolute Maximum Ratings

An absolute maximum rating of the module is as following:

### 4.1 Absolute Ratings of TFT LCD Module

Item	Symbol	Min	Max	Unit	Conditions
Logic/LCD Drive Voltage	Vin	-0.3	+4.5	[Volt]	Note 1,2

### 4.2 Absolute Ratings of Environment

Item	Symbol	Min	Max	Unit	Conditions
Operating Temperature	TOP	0	60	[°C]	Note 4
Operation Humidity	HOP	5	95	[%RH]	Note 4
Storage Temperature	TST	-20	+60	[°C]	Note 4
Storage Humidity	HST	5	95	[%RH]	Note 4

Note 1: At Ta (25°C )

Note 2: Permanent damage to the device may occur if exceed maximum values

Note 3: LED specification refer to section 5.2

Note 4: For quality performance, please refer to AUO IIS (Incoming Inspection Standard).

## 5. Electrical Characteristics

### 5.1 TFT LCD Module

#### 5.1.1 Power Specification

Input power specifications are as follows;

The power specification are measured under 25°C and frame frequency under 60Hz

Symble	Parameter	Min	Typ	Max	Units	Note
VDD	Logic/LCD Drive Voltage	3.0	3.7	4.2	[Volt]	
PDD	VDD Power	-	-	0.95	[Watt]	Note 1
IDD	IDD Current	-	-	316	[mA]	Note 1
IRush	Inrush Current	-	-	2000	[mA]	Note 2
VDDrp	Allowable Logic/LCD Drive Ripple Voltage	-	-	100	[mV] p-p	

Note 1 : Maximum Measurement Condition : White Pattern at 3.7V driving voltage. ( $P_{max}=V_{3.7} \times I_{white}$ )

Note 2 : Measure Condition

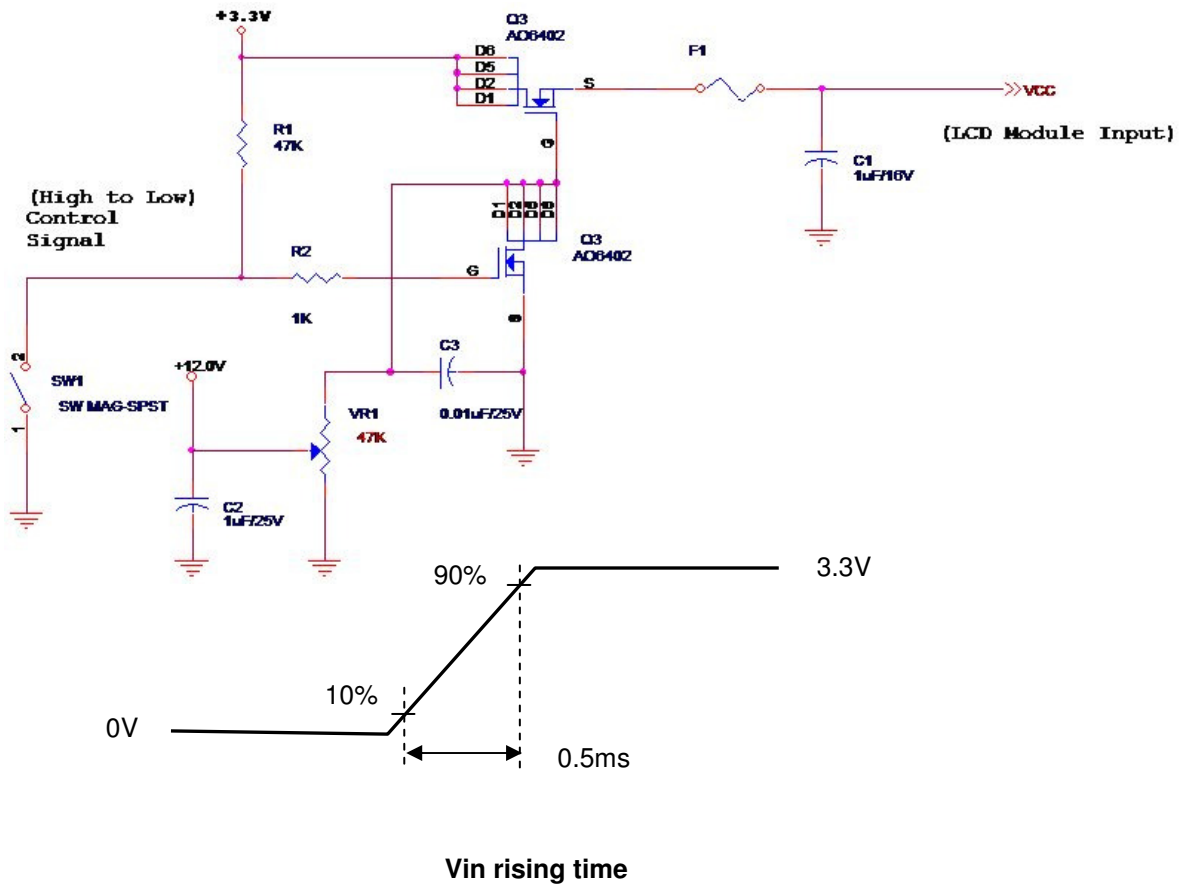

## 5.1.2 Signal Electrical Characteristics

Input signals shall be low or High-impedance state when VDD is off.

MIPI DC/AC Characteristics are as follows;

MIPI Receiver Differential Input (DC Characteristics)					
Symbol	Parameter	Min	Typ	Max	Unit
BR <sub>MIPI</sub>	Input data bit rate	200	-	1000	Mbps
V <sub>CMRX</sub>	Common-mode voltage(HS Rx mode)	70	-	330	mV
V <sub>IDTH</sub>	Differential input high threshold (HS Rx mode)	-	-	70	mV
V <sub>IDTL</sub>	Differential input low threshold (HS Rx mode)	-70	-	-	mV
V <sub>IDM</sub>	Differential input voltage range (HS Rx mode)	70	-	500	mV
V <sub>IHHS</sub>	Single-end input high voltage (HS Rx mode)	-	-	460	mV
V <sub>ILHS</sub>	Single-end input low voltage (HS Rx mode)	-40	-	-	mV
Z <sub>ID</sub>	Differential input impedance	80	100	125	Ω
V <sub>IHLP</sub>	Logic 1 input voltage (LP Rx mode)	880			mV
V <sub>ILLP</sub>	Logic 0 input voltage (LP Rx mode)			550	mV
V <sub>OH</sub>	Output high level (LP Tx mode)	1.08	1.2	1.32	V
V <sub>OL</sub>	Output low level (LP Tx mode)	-50		50	mV

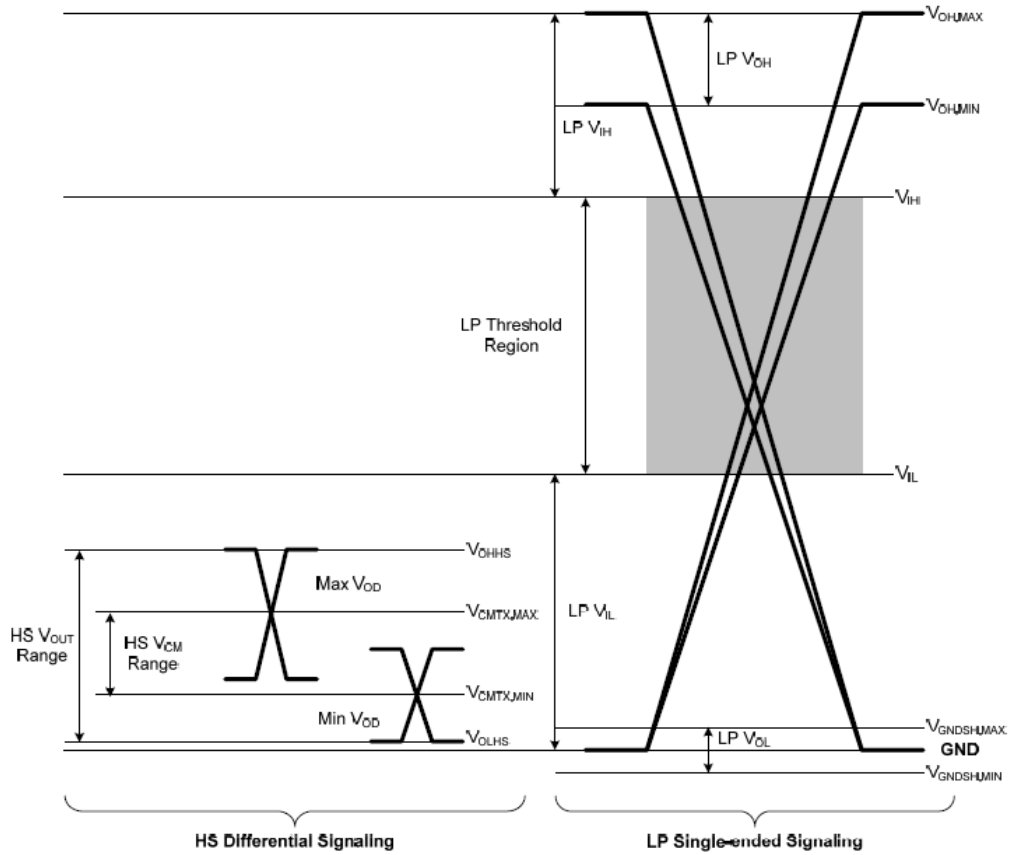

MIPI Receiver Differential Input (AC Characteristics)						
Symbol	Parameter	Conditions	Min	Typ	Max	Unit
$\Delta V_{CMRX(HF)}$	Common-mode interference beyond 450MHz		-	-	100	mV
$\Delta V_{CMRX(LF)}$	Common-mode interference 50MHz ~ 450MHz		-50	-	50	mV
$C_{CM}$	Common-mode termination		-	-	60	pF
$U_{INST}$	UI instantaneous		1		12.5	ns

HS RX Scheme



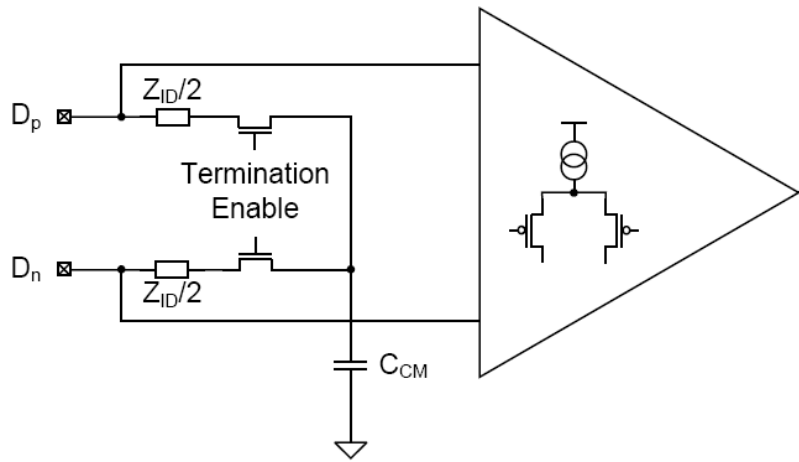

Symbol	Parameter	Min	Typ	Max	Unit	Notes
$T_{SKEW[TX]}$	Data to Clock Skew (mesured at transmitter)	-0.15		0.15	$U_{I_{INST}}$	1
$T_{SETUP[RX]}$	Data to Clock Setup Time (receiver)	0.15			$U_{I_{INST}}$	2
$T_{HOLD[RX]}$	Data to Clock Hold Time (receiver)	0.15			$U_{I_{INST}}$	2

Note:

1. Total silicon and package delay budget of  $0.3 \cdot U_{I_{INST}}$
2. Total setup and hold window for receiver of  $0.3 \cdot U_{I_{INST}}$

### High Speed Data Transmission: Data to Clock Timing

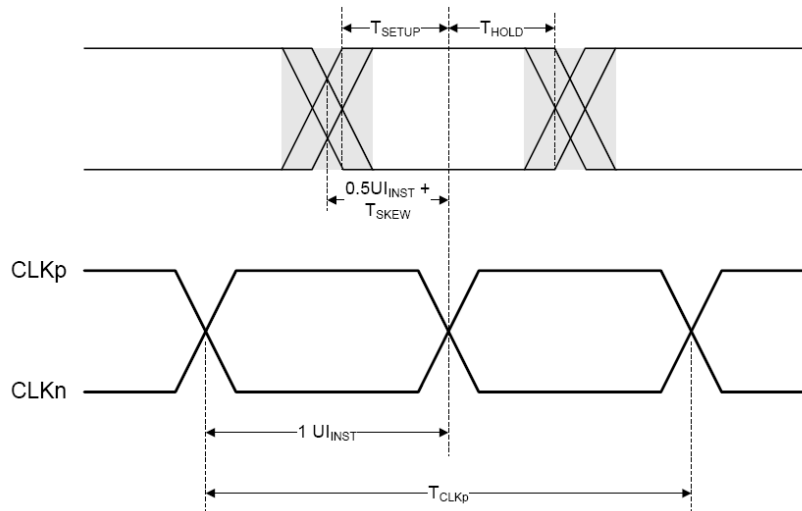

LP Receiver AC Specifications						
Symbol	Parameter	Conditions	Min	Typ	Max	Unit
$e_{SPIKE}$	Input pulse rejection		-	-	300	$V \cdot ps$
$T_{MIN-RX}$	Minimum pulse width response		50	-	-	ns

$V_{INT}$	Peak interference amplitude	-	-	200	mV
$f_{INT}$	Interference frequency	450	-	-	MHz

### Input Glitch Rejection of Low-Power Receivers

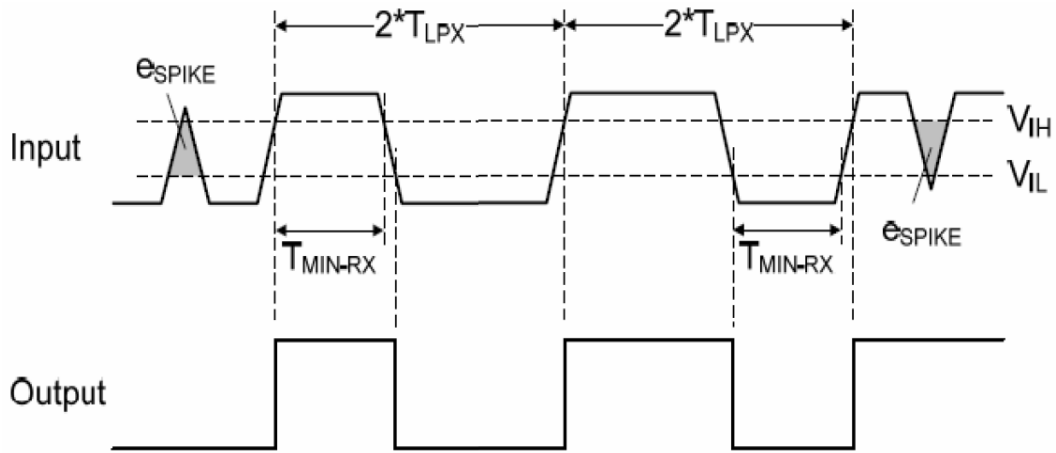

For MIPI data transmission from TX to TCON works properly in video mode, it is suggested that all of MIPI lanes status follow the scheme showed in below. When power is turned on, all lanes (include clock lane) are into LP-11 status first. When TX wants to start transmitting data to TCON, the clock lane is into HS and start toggling. Then data lanes are into HS and data are transmitted. After data transmissions are finished (ex. H-blanking, V-blanking), the data lanes are returned to LP-11, then clock lane, too. The transmission start from LP-11 and stop in LP-11 on all lanes (include clock lane) are the recommended proper operation sequence for MIPI video mode.

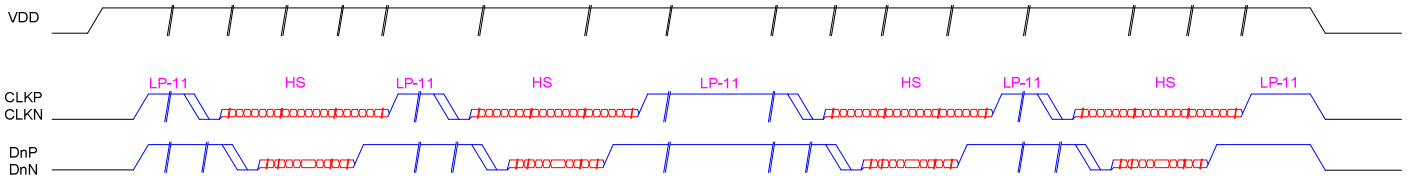

The timing definitions are listed in below,

Parameter	Description	Min	Typ	Max	Unit
TCLK-MISS	Timeout for receiver to detect absence of Clock transitions and disable the Clock Lane HS-RX.			60	ns
TCLK-POST	Time that the transmitter continues to send HS clock after the last associated Data Lane has transitioned to LP Mode. Interval is defined as the period from the end of THS-TRAIL to the beginning of TCLK-TRAIL.	60 ns + 52*UI			ns
TCLK-PRE	Time that the HS clock shall be driven by the transmitter prior to any associated Data Lane beginning the transition from LP to HS mode.	8			UI



# Product Specification

AU OPTRONICS CORPORATION

TCLK-PREPARE	Time that the transmitter drives the Clock Lane LP-00 Line state immediately before the HS-0 Line state starting the HS transmission.	38		95	ns
TCLK-SETTLE	Time interval during which the HS receiver shall ignore any Clock Lane HS transitions, starting from the beginning of TCLK-PREPARE.	95		300	ns
TCLK-TERM-EN	Time for the Clock Lane receiver to enable the HS line termination, starting from the time point when Dn crosses VIL,MAX.			38	ns
TCLK-TRAIL	Time that the transmitter drives the HS-0 state after the last payload clock bit of a HS transmission burst.	60			ns
TCLK-PREPARE + TCLK-ZERO	TCLK-PREPARE + time that the transmitter drives the HS-0 state prior to starting the Clock.	300			ns
TD-TERM-EN	Time for the Data Lane receiver to enable the HS line termination, starting from the time point when Dn crosses VIL,MAX.			35 ns + 4*UI	ns
TEOT	Transmitted time interval from the start of THS-TRAIL or TCLK-TRAIL, to the start of the LP-11 state following a HS burst.			105 ns + 12*UI	ns
THS-EXIT	Time that the transmitter drives LP-11 following a HS burst.	100			ns
THS-SYNC	HS Sync-Sequence '00011101' period		8		UI
THS-PREPARE	Time that the transmitter drives the Data Lane LP-00 Line state immediately before the HS-0 Line state starting the HS transmission	40 ns + 4*UI		85 ns + 6*UI	ns
THS-PREPARE + THS-ZERO	THS-PREPARE + time that the transmitter drives the HS-0 state prior to transmitting the Sync sequence.	145 ns + 10*UI			ns
THS-SETTLE	Time interval during which the HS receiver shall ignore any Data Lane HS transitions, starting from the beginning of THS-PREPARE.	85 ns + 6*UI		145 ns + 10*UI	ns
THS-SKIP	Time interval during which the HS-RX should ignore any transitions on the Data Lane, following a HS burst. The end point of the interval is defined as the beginning of the LP-11 state following the HS burst.	40		55 ns + 4*UI	ns
THS-TRAIL	Time that the transmitter drives the flipped differential state after last payload data bit of a HS transmission burst	60 ns + 4*UI			ns
TLPX	Transmitted length of any Low-Power state period	50			ns
Ratio TLPX	Ratio of TLPX(MASTER)/TLPX(SLAVE) between Master and Slave side	2/3		3/2	
TTA-GET	Time that the new transmitter drives the Bridge state (LP-00) after accepting control during a Link Turnaround.		5*TLPX		ns
TTA-GO	Time that the transmitter drives the Bridge state (LP-00) before releasing control during a Link Turnaround.		4*TLPX		ns
TTA-SURE	Time that the new transmitter waits after the LP-10 state before transmitting the Bridge state (LP-00) during a Link Turnaround.	TLPX		2*TLPX	ns

Note:

1. The minimum value depends on the bit rate. Implementations should ensure proper operation for all the supported bit rates.
2. TLPX is an internal state machine timing reference. Externally measured values may differ slightly from the specified values due to asymmetrical rise and fall times.

## High-Speed Data Transmission in Bursts

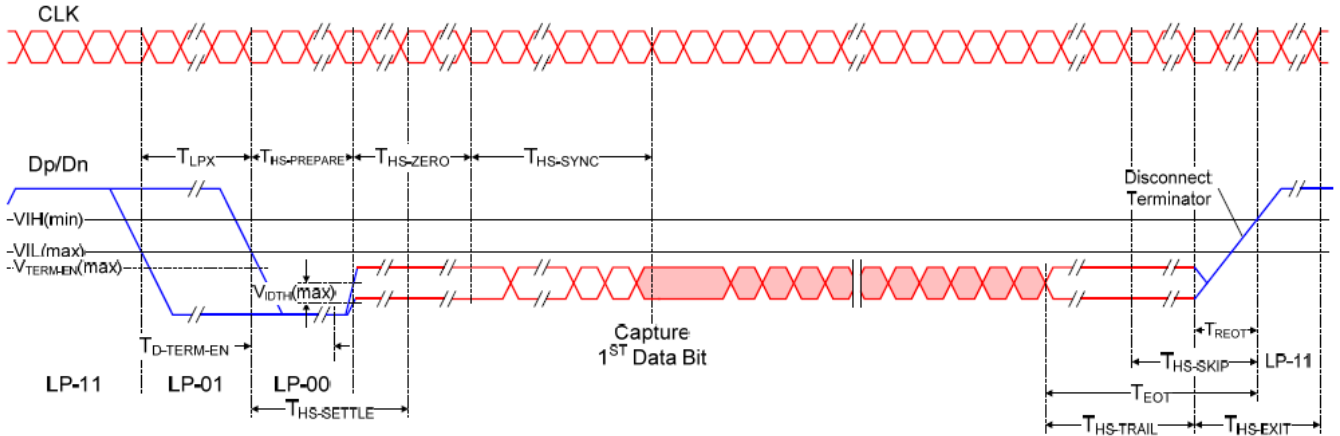

## Switching the Clock Lane between Clock Transmission and Low-Power Mode

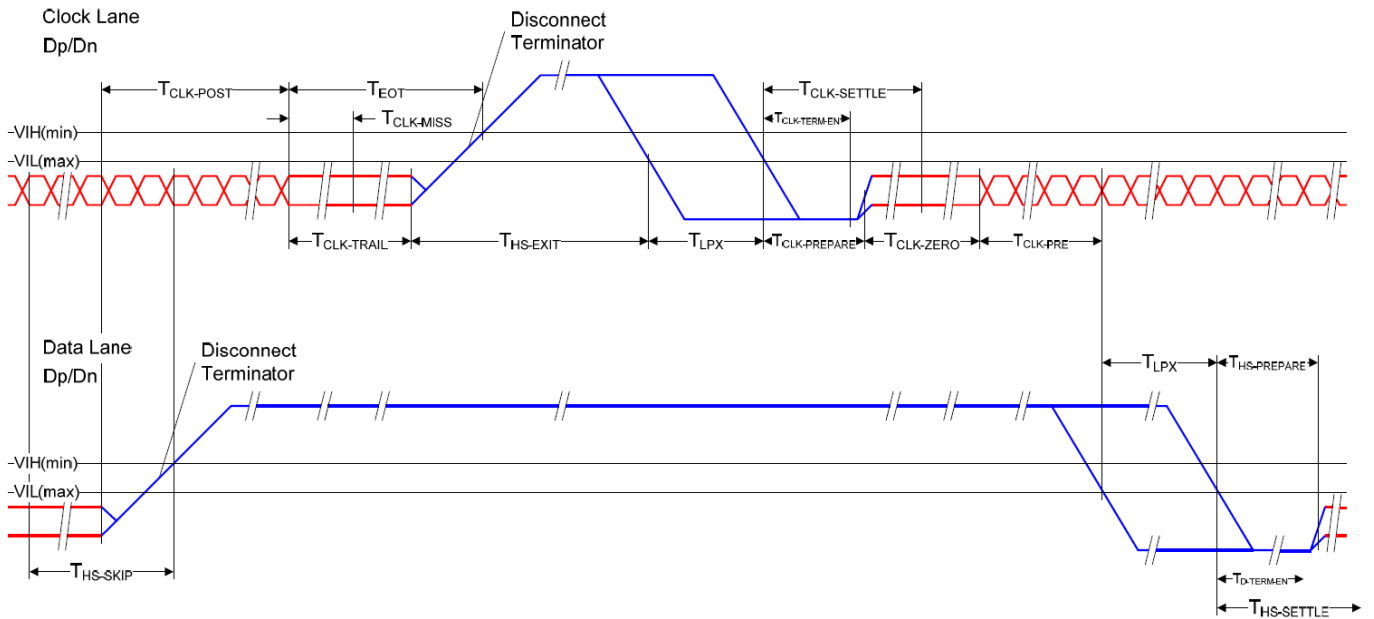

## Turnaround Procedure



## 5.2 Backlight Unit

### 5.2.1 LED characteristics

Parameter	Symbol	Min	Typ	Max	Units	Condition
Backlight Power Consumption	PLED	-	-	<b>2.5</b>	[Watt]	(Ta=25°C @380nits)
LED Life-Time	N/A	<b>12,000</b>	-	-	Hour	(Ta=25°C @380nit) Note1.
LED Forward Voltage	VF	<b>2.7</b>	<b>2.95</b>	<b>3.3</b>	[Volt]	(Ta=25°C)
LED Forward Voltage of every LED string	VF-string	-	<b>14.75</b>	<b>16.5</b>	[Volt]	(Ta=25°C) Note2.
LED Forward Current	IF	-	<b>21</b>	-	[mA]	(Ta=25°C)

**Note 1.** The LED life-time define as the estimated time to 50% degradation of initial luminous.

**Note 2.** LED Array 5 parallel \* 6 series

## 5.2.2 Backlight input signal characteristics

Parameter	Symbol	Min	Typ	Max	Units	Remark
LED Power Supply	VLED	3		5	[Volt]	Define as Connector Interface (Ta=25°C) Note1.
LED Enable Input High Level	VLED_EN	1.8	-	5.5	[Volt]	
LED Enable Input Low Level		-	-	0.8	[Volt]	
PWM Logic Input High Level	VPWM_EN	1.8	-	5.5	[Volt]	
PWM Logic Input Low Level		-	-	0.8	[Volt]	
PWM Input Frequency	FPWM	200	-	20K	Hz	
PWM Duty Ratio	Duty	5		100	%	

Note 1: The input high level voltage conversion to 2.5V by level shift circuit.

Note 2: The LED PWM Logic Input Low Level Voltage must have an output impedance close to 0 ohm in front of input connector.

## 5.2.3 Dynamic contrast ratio Characteristics

Parameter	Symbol	Min	Typ	Max	Units	Remark
DCR Mode Duty Index	Duty	<b>TBD</b>	-	<b>TBD</b>	%	Note 1
L0 Gray level	Power	-	<b>TBD</b>	-	Watt	Note 2
L63 Gray level	Power	-	<b>TBD</b>	-	Watt	

Note 1: The minimums dynamic contrast ratio is setting at darkness, and a maximum is setting at brightness.

Note 2: The power saving capability refer to original Backlight power consumption (P)

## 6. Signal Interface Characteristic

### 6.1 Pixel Format Image

Following figure shows the relationship of the input signals and LCD pixel format.

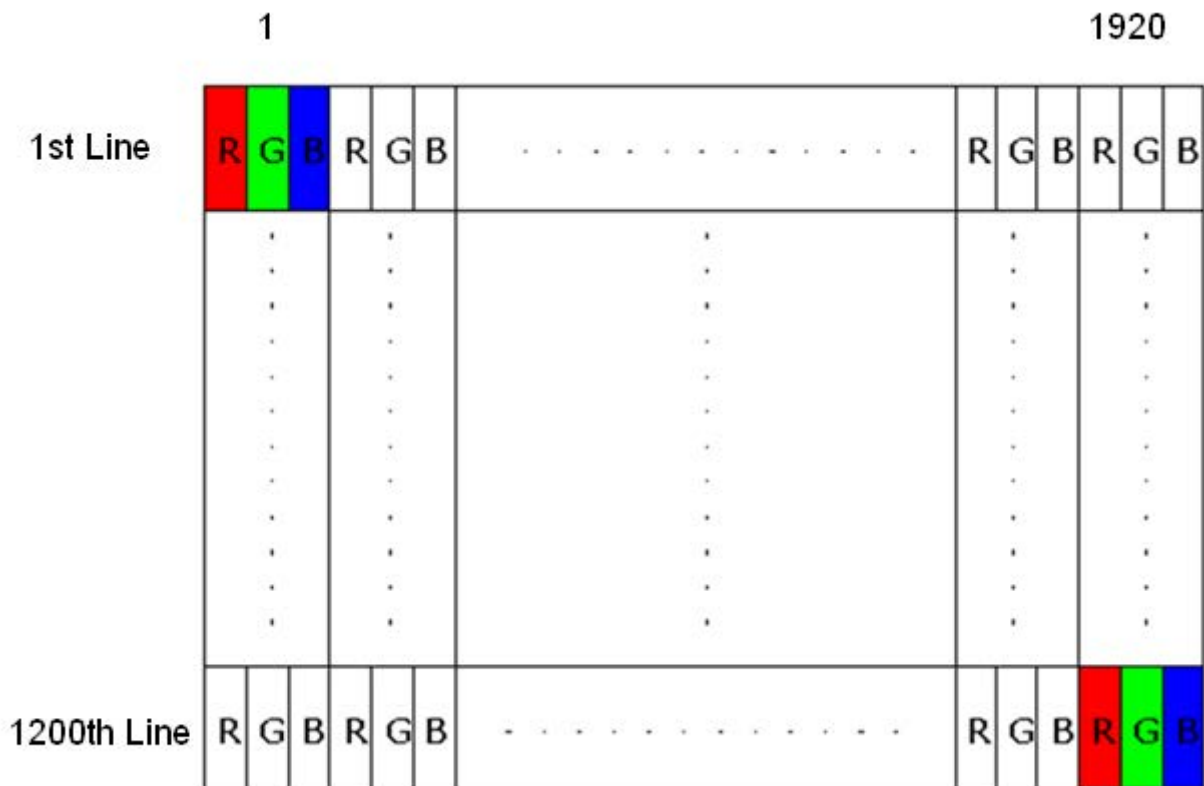

## 6.2 The Input Data Format

Input Pixel Stream Format (1920RGB in 4 Lanes with RGB 8-8-8 format)

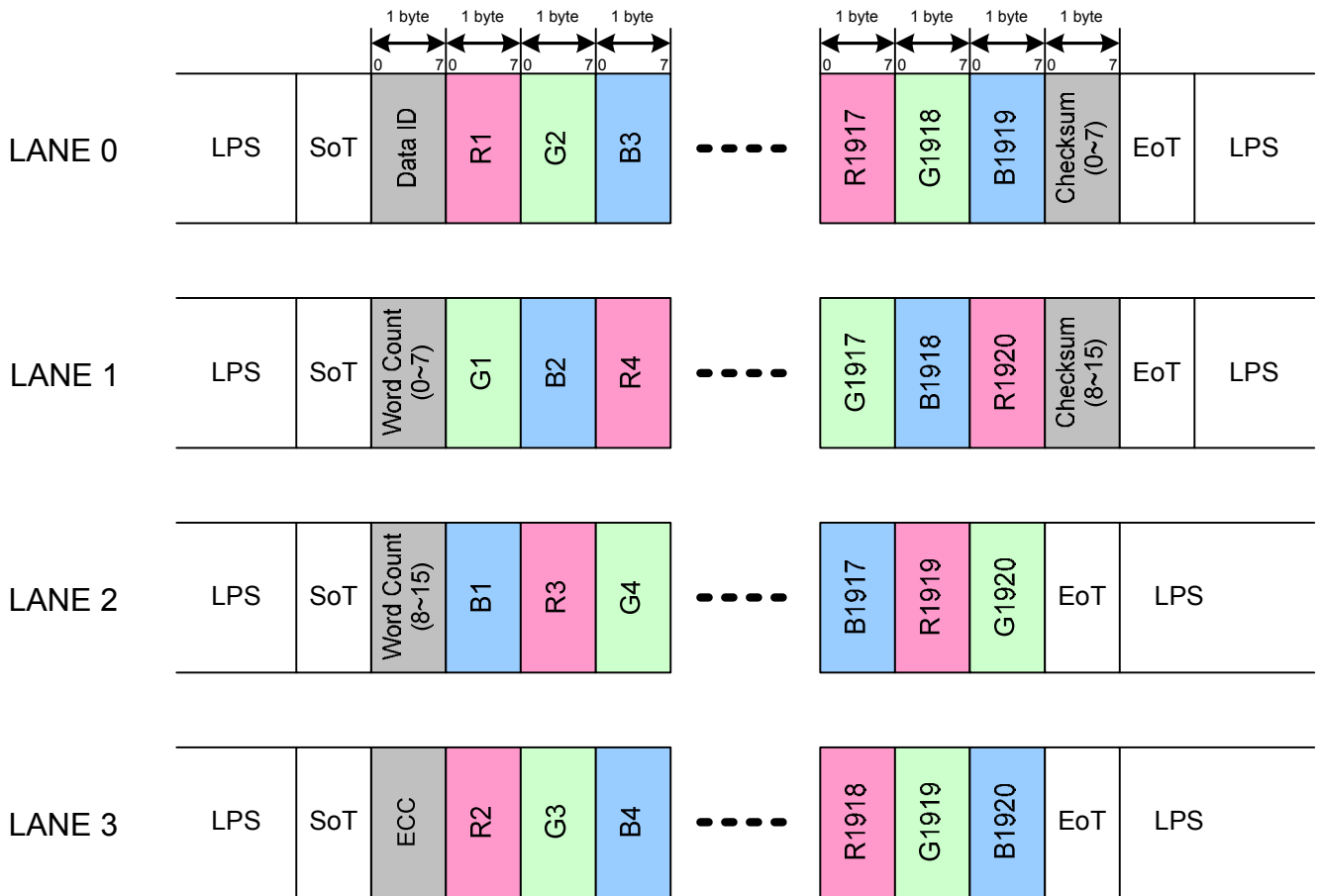

LPS : Low Power State  
 SoT : Start of Transmission  
 EoT : End of Transmission  
 ECC : Error-Correcting Code



## 6.3 Integration Interface Requirement

### 6.3.1 MIPI Connector Description

Physical interface is described as for the connector on module.

These connectors are capable of accommodating the following signals and will be following components.

<b>Connector Name / Designation</b>	<b>For Signal Connector</b>
Manufacturer	HIROSE
Type / Part Number	FH34SJ-34S-0.5SH(50)
Mating Housing/Part Number	FPC Cable

### 6.3.2 MIPI Pin Assignment

MIPI is a differential signal technology for LCD interface and high speed data transfer device.

No.	Pin Name	Description
1	VDD	DC-DC circuit supply voltage (3V~4.2V)
2	VDD	DC-DC circuit supply voltage (3V~4.2V)
3	NC	Not Connection
4	LED_EN	LED driver Enable Input (VIH=1.8V)
5	LED_PWM	Backlight LED driver PWM Input (VIH=1.8V)
6	EDID_SDA	EDID Data Input (VIH=1.8V)
7	EDID_SCL	EDID Clock Input (VIH=1.8V)
8	NC	Not Connection
9	GND	Ground
10	DSI_D2P/Rx-IN2P	MIPI data pair 2 positive signal
11	DSI_D2N/Rx-IN2N	MIPI data pair 2 negative signal
12	GND	Ground
13	DSI_D1P/Rx-IN1P	MIPI data pair 1 positive signal
14	DSI_D1N/Rx-IN1N	MIPI data pair 1 negative signal
15	GND	Ground
16	DSI_CLKP/Rx-CLKP	MIPI Clock positive signal
17	DSI_CLKN/Rx-CLKN	MIPI Clock negative signal
18	GND	Ground
19	DSI_D0P/Rx-IN0P	MIPI data pair 0 positive signal
20	DSI_D0N/Rx-IN0N	MIPI data pair 0 negative signal
21	GND	Ground
22	DSI_D3P/Rx-IN3P	MIPI data pair 3 positive signal
23	DSI_D3N/Rx-IN3N	MIPI data pair 3 negative signal
24	GND	Ground
25	GND	Ground
26	GND	Ground
27	GND	Ground
28	ID	ASUS ID Pin (only ASUS use ; AUO internal floating)
29	Aging	Aging Mode Power Supply (AUO only)
30	NC	Not Connection
31	LED+	LED Power Supply (3V - 5V)
32	LED+	LED Power Supply (3V - 5V)
33	LED+	LED Power Supply (3V - 5V)
34	LED+	LED Power Supply (3V - 5V)

## 6.4 MIPI Interface Timing

### 6.4.1 Timing Characteristics

Basically, interface timings should match the 1920x1200 /60Hz manufacturing guide line timing.

Parameter	Symbol	Min.	Typ.	Max.	Unit	
Frame Rate	---	---	60	---	Hz	
Clock frequency	$1/T_{\text{Clock}}$	146.74	148.35	149.96	MHz	
Vertical Section	Period	$T_V$	1206	1212	1218	$T_{\text{Line}}$
	Active	$T_{VD}$	1200			
	Blanking	$T_{VB}$	6	12	18	
Horizontal Section	Period	$T_H$	2028	2040	2052	$T_{\text{Clock}}$
	Active	$T_{HD}$	1920			
	Blanking	$T_{HB}$	108	120	132	

Note : 1. DE mode only

### 6.4.2 Timing diagram

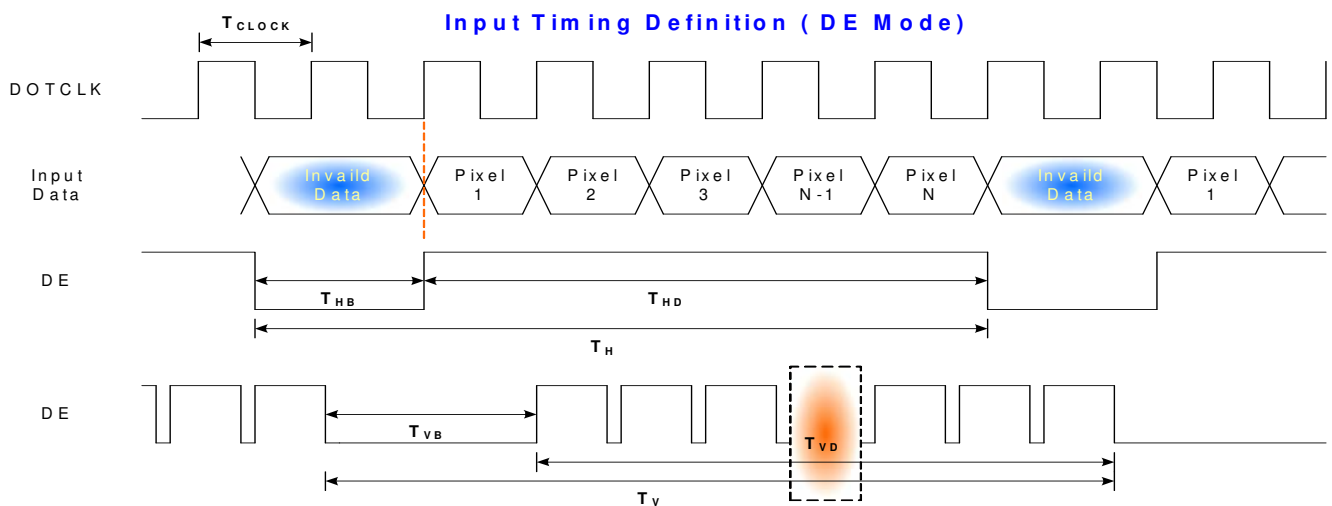

## 6.5 Power ON/OFF Sequence

Power on/off sequence is as follows. Interface signals and LED on/off sequence are also shown in the chart.

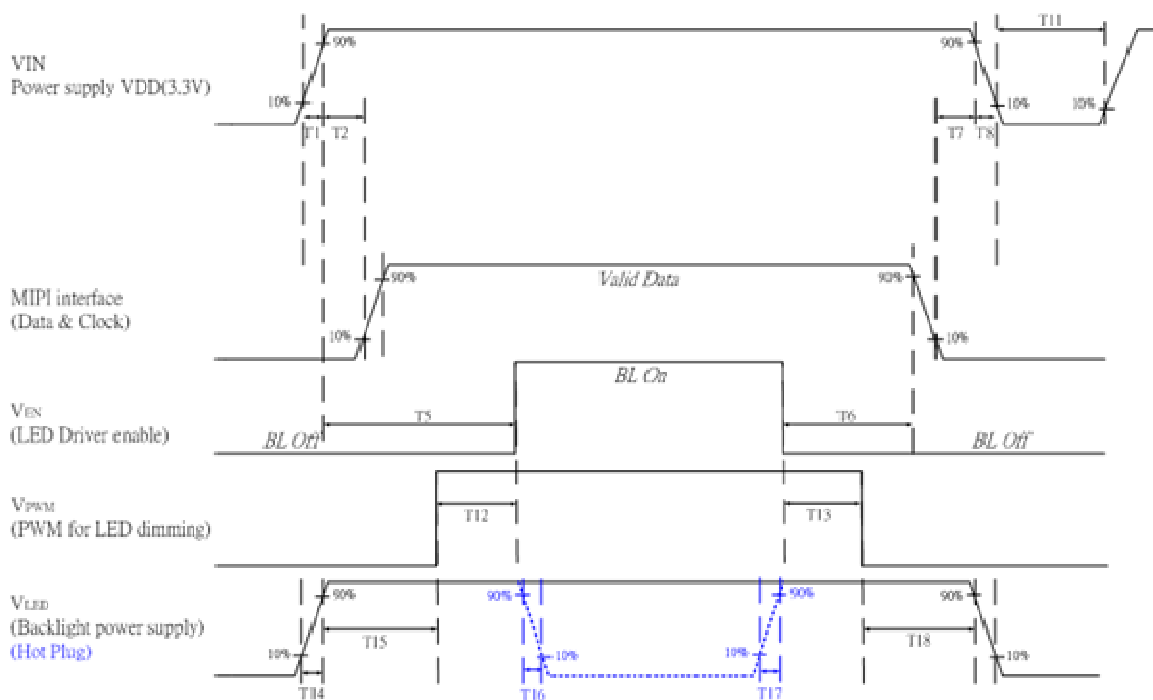

Power Sequence Timing			
Parameter	Value		Units
	Min.	Max.	
T1	0.5	10	ms
T2	0	50	
T5	200	-	
T6	200	-	
T7	0	50	
T8	0	10	
T11	500	-	
T12	10	-	
T13	10	-	
T14	0.5	10	
T15	10	-	
T16	1*	-	
T17	1*	-	
T18	10	-	

Note: LED\_PWM must be pull low(GND) when it is not pull high.

## 7. Panel Reliability Test

### 7.1 Vibration Test

**Test Spec:**

- Test method: Non-Operation
- Acceleration: 1.5 G
- Frequency: 10 - 500Hz Random
- Sweep: 30 Minutes each Axis (X, Y, Z)

### 7.2 Shock Test

**Test Spec:**

- Test method: Non-Operation
- Acceleration: 220 G , Half sine wave
- Active time: 2 ms
- Pulse: X,Y,Z .one time for each side

### 7.3 Reliability Test

Items	Required Condition	Note
Temperature Humidity Bias	Ta= 40°C , 95%RH, 240h	
High Temperature Operation	Ta= 60°C , Dry, 240h	
Low Temperature Operation	Ta= -20°C , 240h	
High Temperature Storage	Ta= 70°C , 240h	
Low Temperature Storage	Ta= -30°C , 240h	
Thermal Shock Test	Ta=-30°C to 70°C , Duration at 30 min, 27 cycles	
ESD	Contact : ±8 KV Air : ±15 KV	Note 1

**Note1:** According to EN 61000-4-2 , ESD class B: Some performance degradation allowed. No data lost  
. Self-recoverable. No hardware failures.

**Remark:** MTBF (Excluding the LED): 30,000 hours with a confidence level 90%

## 8. Mechanical Characteristics

### 8.1 LCM Outline Dimension

#### 8.1.1 Standard Front View

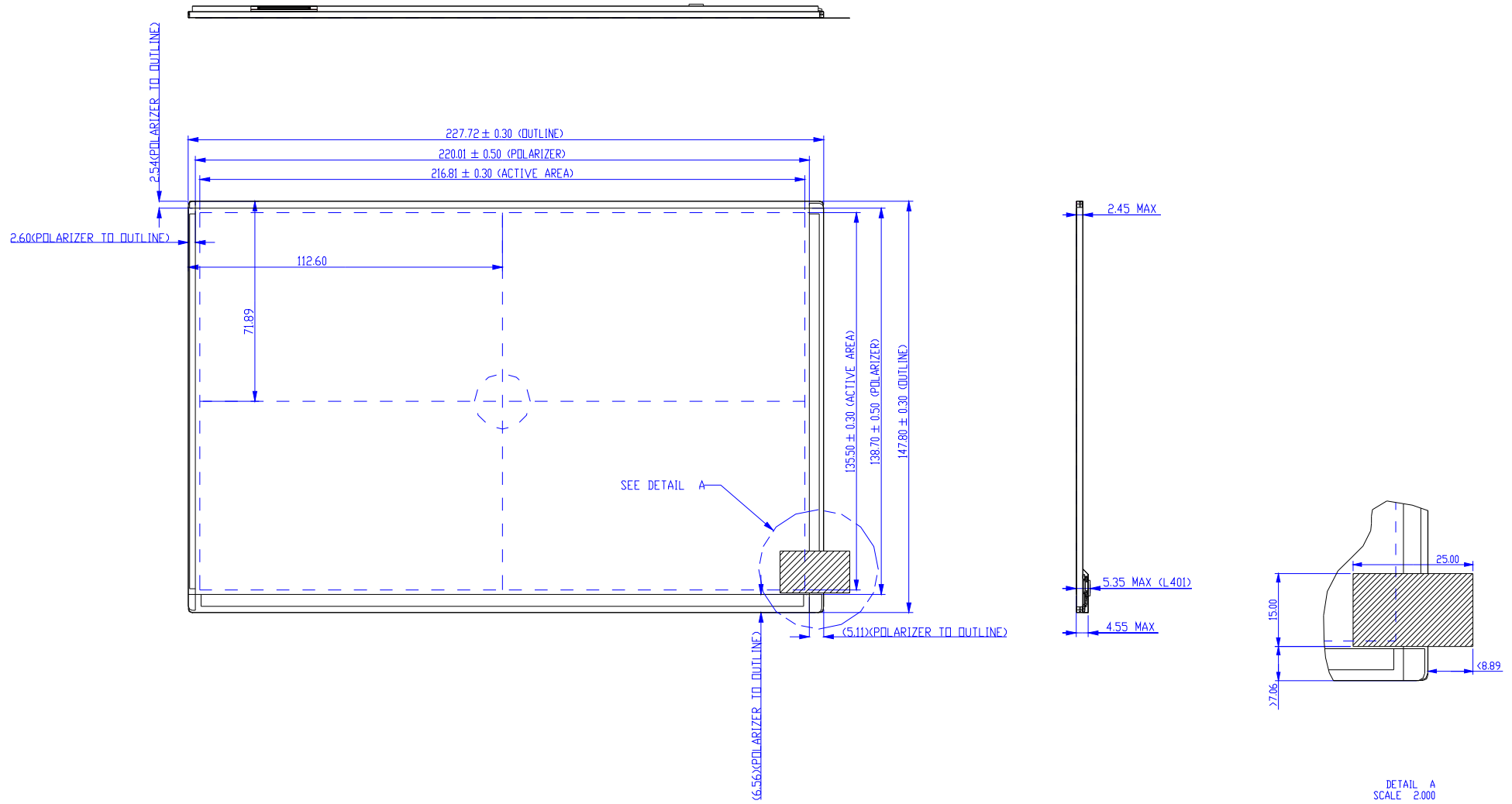

## 8.1.2 Standard Rear View

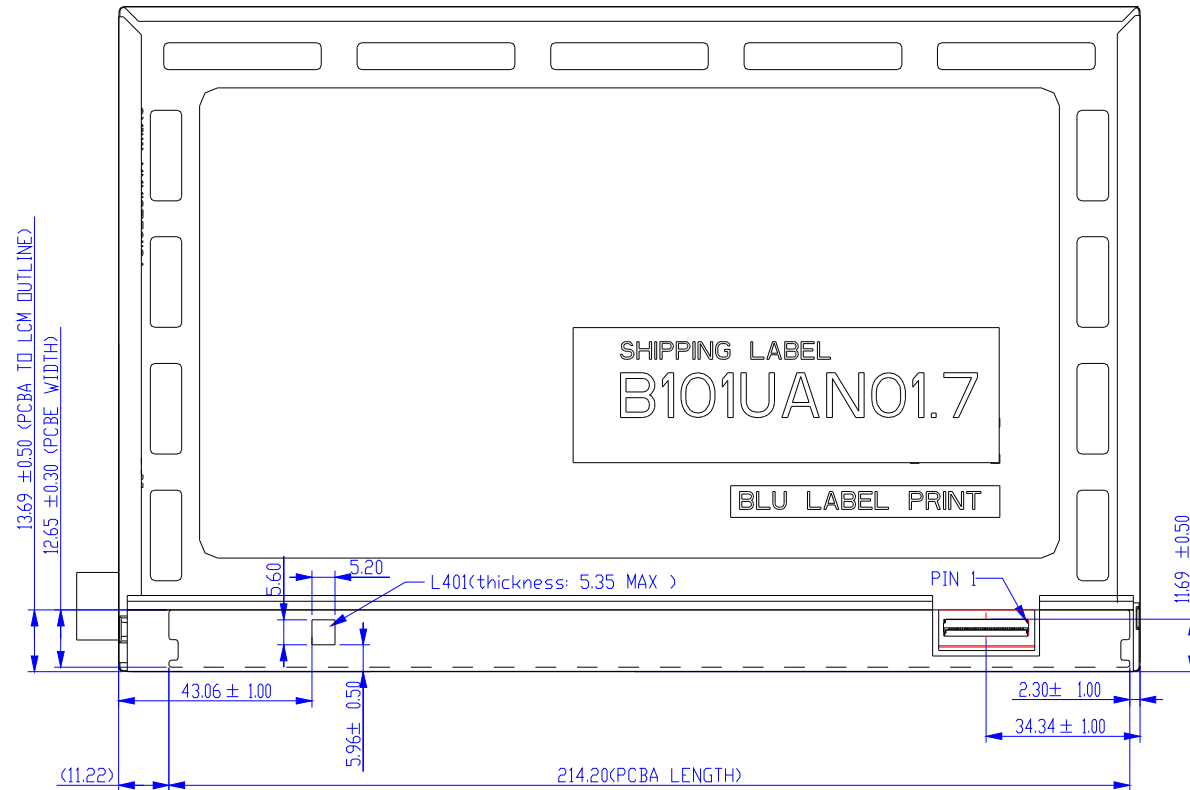

## 9. Shipping and Package

### 9.1 Shipping Label Format

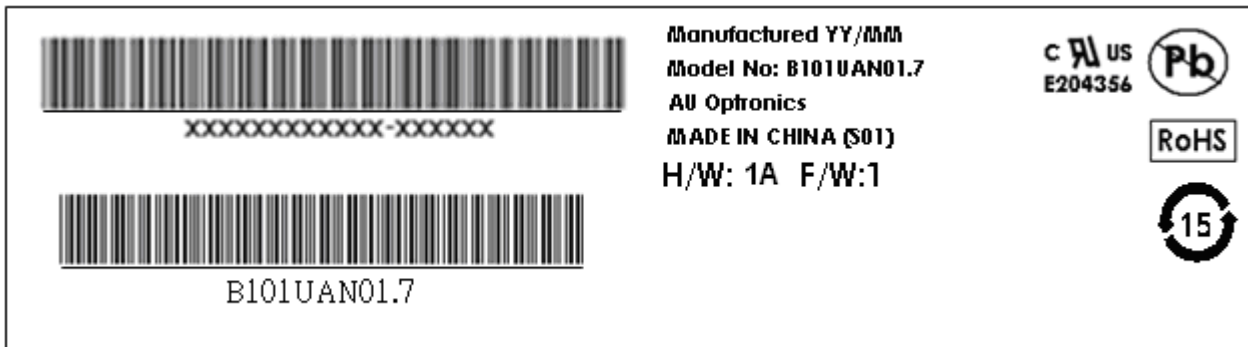



## 9.2 Carton Package

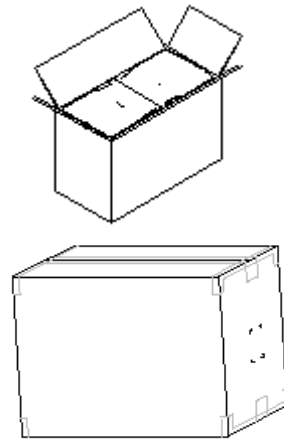

## 9.3 Shipping Package of Palletizing Sequence

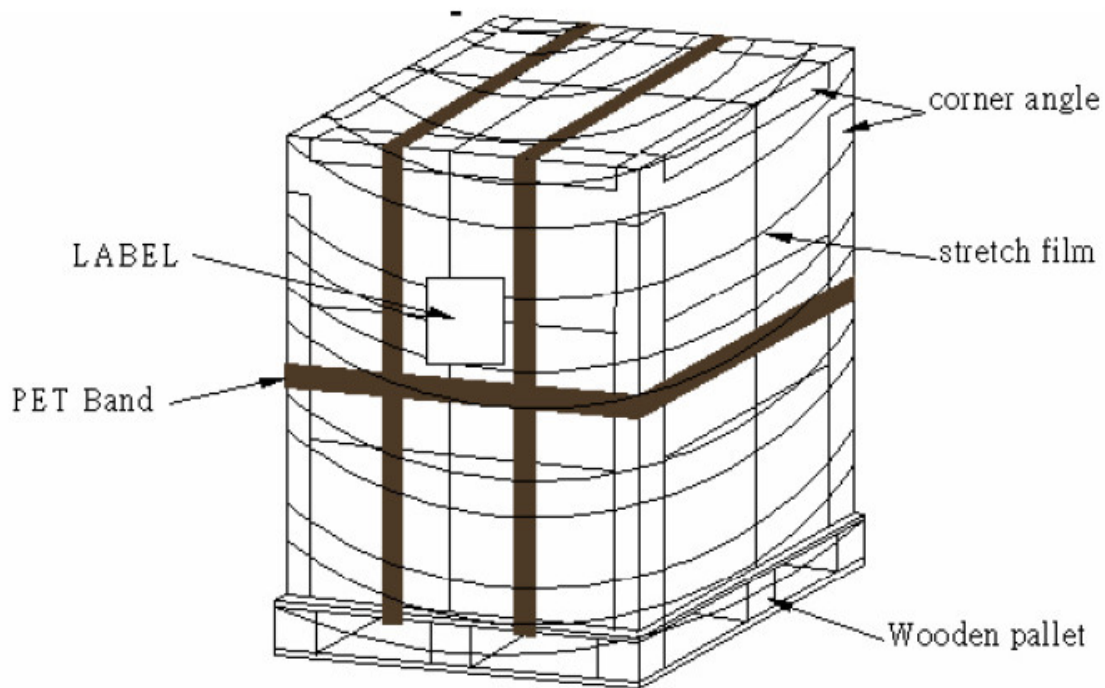

## 10. Appendix

### 10.1 EDID Description

Address	FUNCTION	Value	Value	Value	Note
HEX		HEX	BIN	DEC	
00	Header	00	00000000	0	
01		FF	11111111	255	
02		FF	11111111	255	
03		FF	11111111	255	
04		FF	11111111	255	
05		FF	11111111	255	
06		FF	11111111	255	
07		00	00000000	0	
08	EISA Manuf. Code LSB	06	00000110	6	
09	Compressed ASCII	AF	10101111	175	
0A	Product Code	D8	11011000	216	
0B	hex, LSB first	17	00010111	23	
0C	32-bit ser #	00	00000000	0	
0D		00	00000000	0	
0E		00	00000000	0	
0F		00	00000000	0	
10	Week of manufacture	16	00010110	22	
11	Year of manufacture	17	00010111	23	
12	EDID Structure Ver.	01	00000001	1	
13	EDID revision #	04	00000100	4	
14	<b>Video input def.</b> ( <i>digital I/P, non-TMDS, CRGB</i> )	A0	10100000	160	
15	<b>Max H image size</b> ( <i>rounded to cm</i> )	16	00010110	22	
16	<b>Max V image size</b> ( <i>rounded to cm</i> )	0E	00001110	14	
17	<b>Display Gamma</b> ( <i>=(gamma*100)-100</i> )	78	01111000	120	
18	<b>Feature support</b> ( <i>no DPMS, Active OFF, RGB, tmg Blk#1</i> )	02	00000010	2	
19	Red/green low bits ( <b>Lower 2:2:2:2 bits</b> )	D3	11010011	211	
1A	Blue/white low bits ( <b>Lower 2:2:2:2 bits</b> )	A5	10100101	165	
1B	Red x ( <b>Upper 8 bits</b> )	97	10010111	151	
1C	Red y/ highER 8 bits	57	01010111	87	
1D	Green x	53	01010011	83	
1E	Green y	96	10010110	150	
1F	Blue x	27	00100111	39	
20	Blue y	1F	00011111	31	
21	White x	50	01010000	80	
22	White y	54	01010100	84	
23	Established timing 1	00	00000000	0	
24	Established timing 2	00	00000000	0	
25	Established timing 3	00	00000000	0	
26	Standard timing #1	01	00000001	1	
27		01	00000001	1	
28	Standard timing #2	01	00000001	1	
29		01	00000001	1	
2A	Standard timing #3	01	00000001	1	
2B		01	00000001	1	

2C	Standard timing #4	01	00000001	1	
2D		01	00000001	1	
2E	Standard timing #5	01	00000001	1	
2F		01	00000001	1	
30	Standard timing #6	01	00000001	1	
31		01	00000001	1	
32	Standard timing #7	01	00000001	1	
33		01	00000001	1	
34	Standard timing #8	01	00000001	1	
35		01	00000001	1	
36	Pixel Clock/10000 LSB	F3	11110011	243	
37	Pixel Clock/10000 USB	39	00111001	57	
38	Horz active <b>Lower 8bits</b>	80	10000000	128	
39	Horz blanking <b>Lower 8bits</b>	78	01111000	120	
3A	HorzAct:HorzBlnk <b>Upper 4:4 bits</b>	70	01110000	112	
3B	Vertical Active <b>Lower 8bits</b>	B0	10110000	176	
3C	Vertical Blanking <b>Lower 8bits</b>	0C	00001100	12	
3D	Vert Act : Vertical Blanking <b>(upper 4:4 bit)</b>	40	01000000	64	
3E	HorzSync. Offset	28	00101000	40	
3F	HorzSync.Width	28	00101000	40	
40	VertSync.Offset : VertSync.Width	44	01000100	68	
41	Horz&Vert Sync Offset/Width <b>Upper 2bits</b>	00	00000000	0	
42	Horizontal Image Size <b>Lower 8bits</b>	D8	11011000	216	
43	Vertical Image Size <b>Lower 8bits</b>	87	10000111	135	
44	Horizontal & Vertical Image Size <b>(upper 4:4 bits)</b>	00	00000000	0	
45	Horizontal Border <i>(zero for internal LCD)</i>	00	00000000	0	
46	Vertical Border <i>(zero for internal LCD)</i>	00	00000000	0	
47	Signal <i>(non-intr, norm, no stero, sep sync, neg pol)</i>	18	00011000	24	
48	Detailed timing/monitor	00	00000000	0	
49	descriptor #2	00	00000000	0	
4A		00	00000000	0	
4B		0F	00001111	15	
4C		00	00000000	0	
4D		00	00000000	0	
4E		00	00000000	0	
4F		00	00000000	0	
50		00	00000000	0	
51		00	00000000	0	
52		00	00000000	0	
53		00	00000000	0	
54		00	00000000	0	
55		00	00000000	0	
56		00	00000000	0	
57		00	00000000	0	
58		00	00000000	0	
59		20	00100000	32	
5A	Detailed timing/monitor	00	00000000	0	
5B	descriptor #3	00	00000000	0	
5C		00	00000000	0	

5D		FE	11111110	254	
5E		00	00000000	0	
5F	Manufacture	41	01000001	65	A
60	Manufacture	55	01010101	85	U
61	Manufacture	4F	01001111	79	O
62		0A	00001010	10	
63		20	00100000	32	
64		20	00100000	32	
65		20	00100000	32	
66		20	00100000	32	
67		20	00100000	32	
68		20	00100000	32	
69		20	00100000	32	
6A		20	00100000	32	
6B		20	00100000	32	
6C	Detailed timing/monitor	00	00000000	0	
6D	descriptor #4	00	00000000	0	
6E		00	00000000	0	
6F		FE	11111110	254	
70		00	00000000	0	
71	Manufacture P/N	42	01000010	66	B
72	Manufacture P/N	31	00110001	49	1
73	Manufacture P/N	30	00110000	48	0
74	Manufacture P/N	31	00110001	49	1
75	Manufacture P/N	55	01010101	85	U
76	Manufacture P/N	41	01000001	65	A
77	Manufacture P/N	4E	01001110	78	N
78	Manufacture P/N	30	00110000	48	0
79	Manufacture P/N	31	00110001	49	1
7A	Manufacture P/N	2E	00101110	46	.
7B	Manufacture P/N	37	00110111	55	7
7C		20	00100000	32	
7D		0A	00001010	10	
7E	Extension Flag	00	00000000	0	
7F	Checksum	2C	00101100	44	
SUM				6656	
SUM to					
HEX				1A00	