

Silicon PNP Power Transistors

2SB1064

DESCRIPTION

- With TO-220 package
- Complement to type 2SD1505
- Low collector saturation voltage

APPLICATIONS

- Designed for use in low frequency power amplifier applications

PINNING

PIN	DESCRIPTION
1	Emitter
2	Collector;connected to mounting base
3	Base

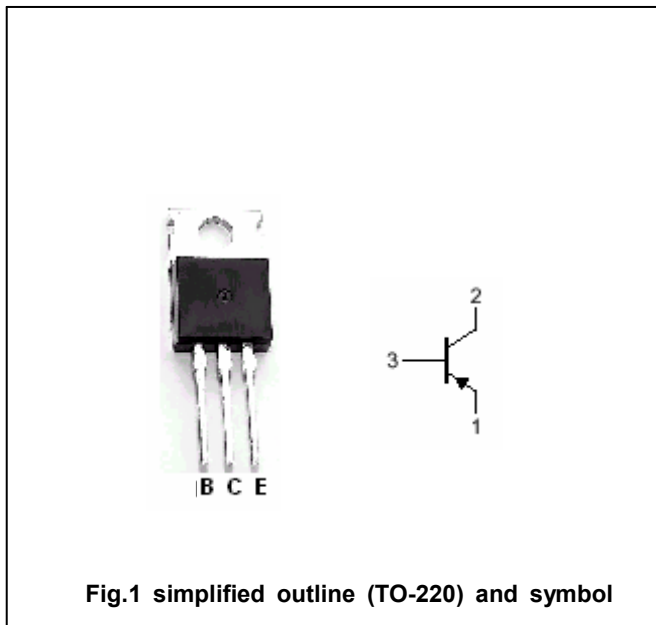

Absolute maximum ratings(Ta=25°C)

SYMBOL	PARAMETER	CONDITIONS	VALUE	UNIT
V <sub>CBO</sub>	Collector-base voltage	Open emitter	-60	V
V <sub>CEO</sub>	Collector-emitter voltage	Open base	-50	V
V <sub>EBO</sub>	Emitter-base voltage	Open collector	-5	V
I <sub>C</sub>	Collector current		-3	A
I <sub>CM</sub>	Collector current-peak		-4.5	A
I <sub>B</sub>	Base current		-0.5	A
P <sub>C</sub>	Collector power dissipation	T <sub>C</sub> =25°C	30	W
T <sub>j</sub>	Junction temperature		150	°C
T <sub>stg</sub>	Storage temperature		-55~150	°C

## Silicon PNP Power Transistors

## 2SB1064

## CHARACTERISTICS

T<sub>j</sub>=25 °C unless otherwise specified

SYMBOL	PARAMETER	CONDITIONS	MIN	TYP.	MAX	UNIT
V <sub>(BR)CEO</sub>	Collector-emitter breakdown voltage	I <sub>C</sub> =-1mA, I <sub>B</sub> =0	-50			V
V <sub>(BR)CBO</sub>	Collector-base breakdown voltage	I <sub>C</sub> =-50μA, I <sub>E</sub> =0	-60			V
V <sub>(BR)EBO</sub>	Emitter-base breakdown voltage	I <sub>E</sub> =-50μA, I <sub>C</sub> =0	-5			V
V <sub>CEsat</sub>	Collector-emitter saturation voltage	I <sub>C</sub> =-2A; I <sub>B</sub> =-0.2A			-1.0	V
V <sub>BEsat</sub>	Base-emitter saturation voltage	I <sub>C</sub> =-2A; I <sub>B</sub> =-0.2A			-1.5	V
I <sub>CBO</sub>	Collector cut-off current	V <sub>CB</sub> =-40V; I <sub>E</sub> =0			-1.0	μA
I <sub>EBO</sub>	Emitter cut-off current	V <sub>EB</sub> =-4V; I <sub>C</sub> =0			-1.0	μA
h <sub>FE</sub>	DC current gain	I <sub>C</sub> =-0.5A; V <sub>CE</sub> =-3V	60		320	
C <sub>OB</sub>	Output capacitance	I <sub>E</sub> =0; V <sub>CB</sub> =-10V, f=1MHz		50		pF
f <sub>T</sub>	Transition frequency	I <sub>C</sub> =-0.5A; V <sub>CE</sub> =-5V		70		MHz

Silicon PNP Power Transistors

2SB1064

PACKAGE OUTLINE

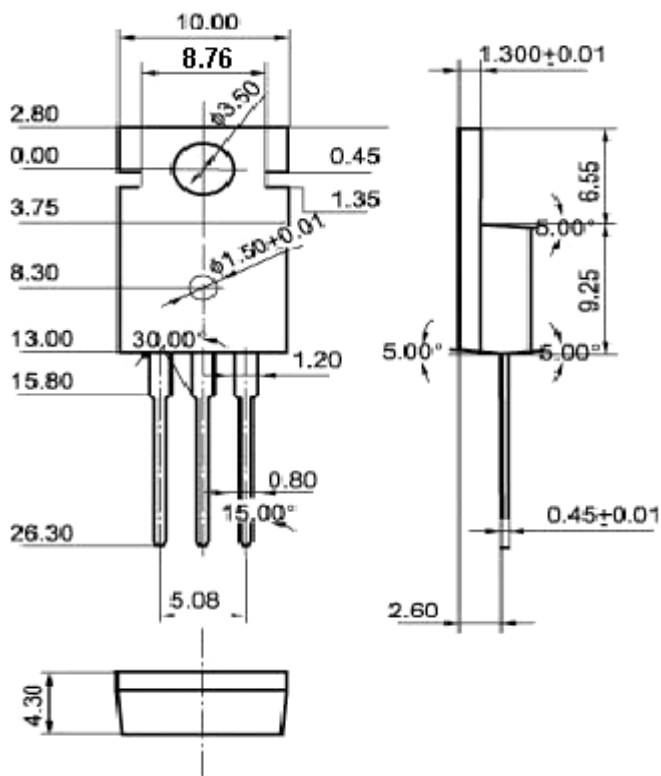

Fig.2 Outline dimensions(unindicated tolerance:±0.10 mm)