



## Product Specification

AU OPTRONICS CORPORATION

- ( ) Preliminary Specifications
- (V) Final Specifications

<b>Module</b>	12.1" WXGA Color TFT-LCD
<b>Model Name</b>	B121EW03 V6 (HW 0A/1A)

<b>Customer</b>	<b>Date</b>
<b>Checked &amp; Approved by</b>	<b>Date</b>
_____	_____
Note: This Specification is subject to change without notice.	

<b>Approved by</b>	<b>Date</b>
<u>Kendra Wang</u>	<u>05/16/2008</u>
<b>Prepared by</b>	<b>Date</b>
<u>Emerson Huang</u>	<u>05/16/2008</u>
<b>NBBU Marketing Division / AU Optronics corporation</b>	



## Product Specification

AU OPTRONICS CORPORATION

### Contents

1. Handling Precautions .....	4
2. General Description .....	5
2.1 General Specification .....	5
2.2 Optical Characteristics .....	6
3. Functional Block Diagram .....	11
4. Absolute Maximum Ratings.....	12
4.1 Absolute Ratings of TFT LCD Module.....	12
4.2 Absolute Ratings of Backlight Unit.....	12
4.3 Absolute Ratings of Environment .....	12
5. Electrical characteristics .....	13
5.1 TFT LCD Module.....	13
5.2 Backlight Unit .....	15
6. Signal Characteristic .....	17
6.1 Pixel Format Image .....	17
6.2 The input data format .....	18
6.3 Signal Description/Pin Assignment.....	19
6.4 Interface Timing .....	22
7. Connector Description.....	25
7.1 TFT LCD Module.....	25
7.2 Backlight Unit .....	25
7.3 Signal for Lamp connector .....	25
8. Dynamic Test .....	26
8.1 Vibration Test .....	26
8.2 Shock Test Spec:.....	26
9. Reliability.....	27
10. Mechanical Characteristics.....	28
10.1 LCM Outline Dimension.....	28
10.2 Screw Hole Depth and Center Position.....	30
11. Shipping and Package .....	31
11.1 Shipping Label Format .....	31
11.2 Carton package .....	32
11.3 Shipping package of palletizing sequence.....	32
12. Appendix: EDID description .....	33



## Product Specification

AU OPTRONICS CORPORATION

### Record of Revision

Version and Date	Page	Old description	New Description	Remark
0.1 2007/9/17	All	First Edition		
0.2 2007/10/3	29-30	LCM drawings	Updated LCM drawings	
0.3 2008/01/10	5,6	210 typ. (5 points average) 178 min. (5 points average)	200 typ. (5 points average) 170 min. (5 points average)	
0.3 2008/01/10	33-35	Non EDID	Add EDID	
0.3 2008/01/10	1	Preliminary spec	Final spec	
1.0 2008/03/31	29	Label position change		
1.1 2008/05/16	31	Add green mark on label		



## Product Specification

AU OPTRONICS CORPORATION

### 1. Handling Precautions

- 1) Since front polarizer is easily damaged, pay attention not to scratch it.
- 2) Be sure to turn off power supply when inserting or disconnecting from input connector.
- 3) Wipe off water drop immediately. Long contact with water may cause discoloration or spots.
- 4) When the panel surface is soiled, wipe it with absorbent cotton or other soft cloth.
- 5) Since the panel is made of glass, it may break or crack if dropped or bumped on hard surface.
- 6) Since CMOS LSI is used in this module, take care of static electricity and insure human earth when handling.
- 7) Do not open nor modify the Module Assembly.
- 8) Do not press the reflector sheet at the back of the module to any directions.
- 9) In case if a Module has to be put back into the packing container slot after once it was taken out from the container, do not press the center of the CCFL Reflector edge. Instead, press at the far ends of the CCFL Reflector edge softly. Otherwise the TFT Module may be damaged.
- 10) At the insertion or removal of the Signal Interface Connector, be sure not to rotate nor tilt the Interface Connector of the TFT Module.
- 11) After installation of the TFT Module into an enclosure (Notebook PC Bezel, for example), do not twist nor bend the TFT Module even momentary. At designing the enclosure, it should be taken into consideration that no bending/twisting forces are applied to the TFT Module from outside. Otherwise the TFT Module may be damaged.
- 12) Cold cathode fluorescent lamp (CCFL) in LCD contains a small amount of mercury. Please follow local ordinances or regulations for disposal.
- 13) Small amount of materials having no flammability grade is used in the LCD module. The LCD module should be supplied by power complied with requirements of Limited Power Source (IEC60950 or UL1950), or be applied exemption.
- 14) The LCD module is designed so that the CCFL in it is supplied by Limited Current Circuit (IEC60950 or UL1950). Do not connect the CCFL in Hazardous Voltage Circuit.



## Product Specification

AU OPTRONICS CORPORATION

### 2. General Description

B121EW03 V6 is a Color Active Matrix Liquid Crystal Display composed of a TFT LCD panel, a driver circuit, and backlight system. The screen format is intended to support the WXGA (1280(H) x 800(V)) screen and 262k colors (RGB 6-bits data driver) without backlight inverter. All input signals are LVDS interface compatible.

B121EW03 V6 is designed for a display unit of notebook style personal computer and industrial machine.

### 2.1 General Specification

The following items are characteristics summary on the table at 25

 condition:

Items	Unit	Specifications												
Screen Diagonal	[mm]	307.9 (12.1W")												
Active Area	[mm]	261.1 X 163.2												
Pixels H x V		1280x3(RGB) x 800												
Pixel Pitch	[mm]	0.204X0.204												
Pixel Format		R.G.B. Vertical Stripe												
Display Mode		Normally White												
White Luminance (ICCF <sub>L</sub> =6.0mA) Note: ICCFL is lamp current	[cd/m <sup>2</sup> ]	200 typ. (5 points average) 170 min. (5 points average) (Note1)												
Luminance Uniformity		1.25 max. (5 points)												
Contrast Ratio		400 typ												
Response Time	[ms]	16 typ / 25 Max												
Nominal Input Voltage VDD	[Volt]	+3.3 typ.												
Power Consumption	[Watt]	4.5 max.												
Weight	[Grams]	290 max.												
Physical Size	[mm]L	<table border="1"> <thead> <tr> <th></th> <th>W</th> <th>T</th> </tr> </thead> <tbody> <tr> <td>Max276.32</td> <td>178.5</td> <td>5.5</td> </tr> <tr> <td>Typical275.82</td> <td>178.0</td> <td>-</td> </tr> <tr> <td>Min275.32</td> <td>177.5</td> <td>-</td> </tr> </tbody> </table>		W	T	Max276.32	178.5	5.5	Typical275.82	178.0	-	Min275.32	177.5	-
	W	T												
Max276.32	178.5	5.5												
Typical275.82	178.0	-												
Min275.32	177.5	-												
Electrical Interface		1 channel LVDS												
Surface Treatment		Anit-glare, Hardness 3H,												



## Product Specification

AU OPTRONICS CORPORATION

Support Color		262K colors ( RGB 6-bit )
Temperature Range Operating Storage (Non-Operating)	[°C] [°C]	0 to +50 -20 to +60
RoHS Compliance		RoHS Compliance

### 2.2 Optical Characteristics

The optical characteristics are measured under stable conditions at 25 °C (Room Temperature) :

Item	Unit	Conditions	Min.	Typ.	Max.	Note
<b>White Luminance</b> ICCF <sub>L</sub> =6.0mA	[cd/m <sup>2</sup> ]	<b>5 points average</b>	<b>170</b>	<b>200</b>	-	1, 4, 5.
<b>Viewing Angle</b>	[degree]	<b>Horizontal</b>	-	<b>40</b>	-	8
	[degree]	<b>(Right)</b>	-	<b>40</b>	-	
	[degree]	<b>CR = 10 (Left)</b>	-	<b>40</b>	-	
	[degree]	<b>Vertical</b>	-	<b>20</b>	-	
	[degree]	<b>(Upper)</b>	-	<b>40</b>	-	
	[degree]	<b>CR = 10 (Lower)</b>	-	<b>40</b>	-	
<b>Luminance Uniformity</b>		<b>5 Points</b>	-	-	<b>1.25</b>	1
<b>CR: Contrast Ratio</b>			<b>300</b>	<b>400</b>	-	6
<b>Cross talk</b>	%				<b>4</b>	7
<b>Response Time</b>	[msec]	<b>Rising</b>	-	-	-	8
	[msec]	<b>Falling</b>	-	-	-	
	[msec]	<b>Rising + Falling</b>	-	<b>16</b>	<b>25</b>	2,8
<b>Chromaticity of color Coordinates</b> (CIE 1931)		<b>Red x</b>	<b>0.550</b>	<b>0.580</b>	<b>0.610</b>	
		<b>Red y</b>	<b>0.310</b>	<b>0.340</b>	<b>0.370</b>	
		<b>Green x</b>	<b>0.280</b>	<b>0.310</b>	<b>0.340</b>	
		<b>Green y</b>	<b>0.520</b>	<b>0.550</b>	<b>0.580</b>	
		<b>Blue x</b>	<b>0.125</b>	<b>0.155</b>	<b>0.185</b>	
		<b>Blue y</b>	<b>0.115</b>	<b>0.145</b>	<b>0.175</b>	
		<b>White x</b>	<b>0.283</b>	<b>0.313</b>	<b>0.343</b>	
		<b>White y</b>	<b>0.299</b>	<b>0.329</b>	<b>0.359</b>	
<b>NTSC</b>	%	<b>CIE 1931</b>	-	<b>45</b>	-	



# Product Specification

AU OPTRONICS CORPORATION

Note 1: 5 points position (Ref: Active area)

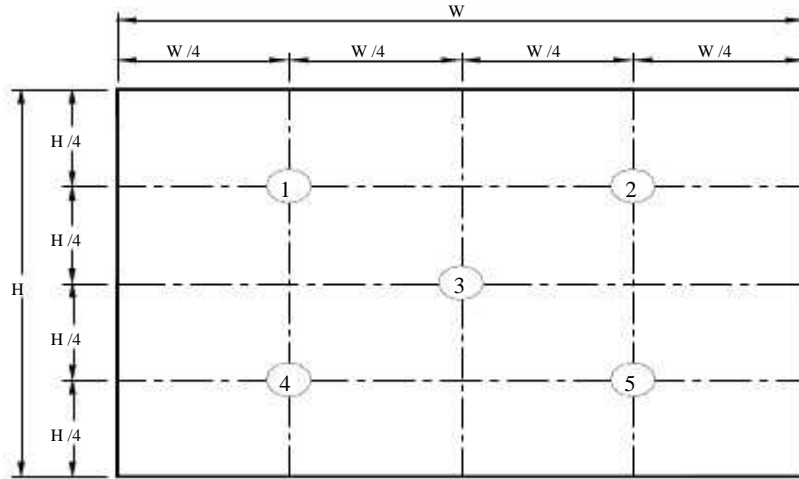

Note 2: 13 points position (Ref: Active area)

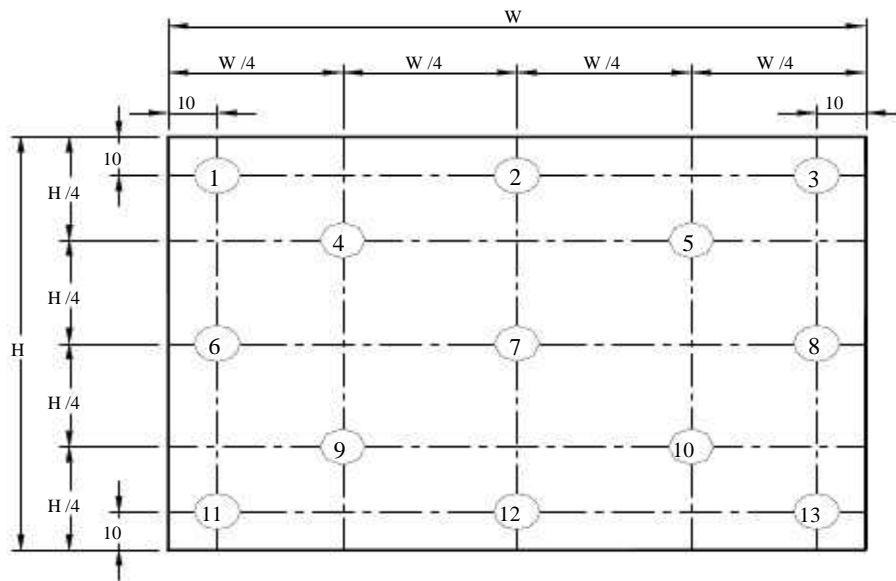

Note 3: The luminance uniformity of 5 or 13 points is defined by dividing the maximum luminance values by the minimum test point luminance

$$M_{w5} = \frac{\text{Maximum Brightness of five points}}{\text{Minimum Brightness of five points}}$$

$$M_{w13} = \frac{\text{Maximum Brightness of thirteen points}}{\text{Minimum Brightness of thirteen points}}$$

Note 4: Measurement method



## Product Specification

AU OPTRONICS CORPORATION

The LCD module should be stabilized at given temperature for 30 minutes to avoid abrupt temperature change during measuring. In order to stabilize the luminance, the measurement should be executed after lighting Backlight for 30 minutes in a stable, windless and dark room.

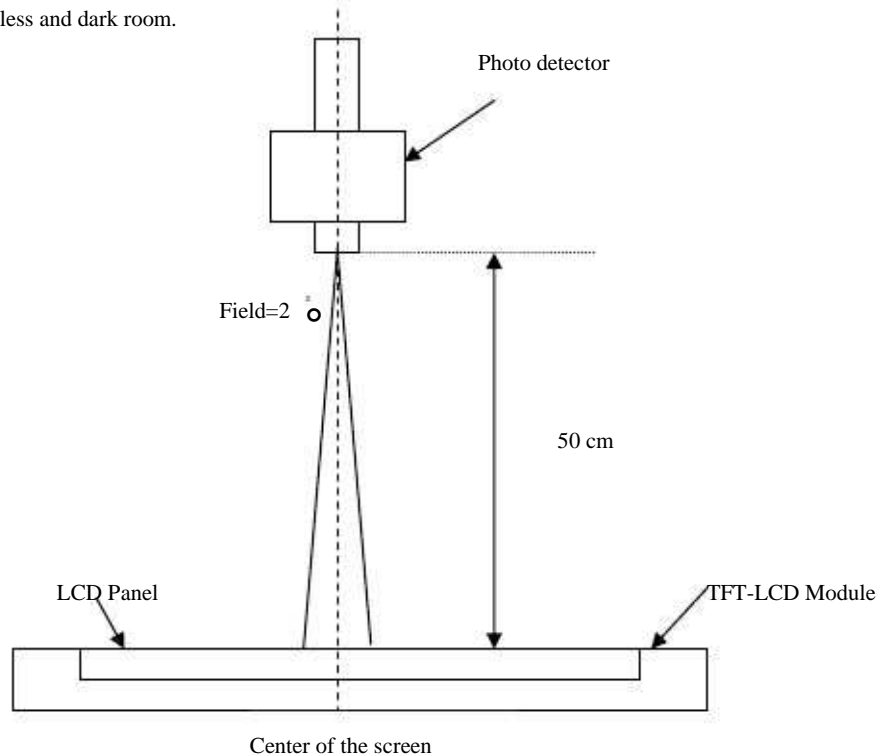

Note 5 : Definition of Average Luminance of White ( $Y_L$ ):

Measure the luminance of gray level 63 at 5 points

$$Y_L = [L(1) + L(2) + L(3) + L(4) + L(5)] / 5$$

$L(x)$  is corresponding to the luminance of the point X at Figure in Note (1).

Note 6 : Definition of contrast ratio:

Contrast ratio is calculated with the following formula.

$$\text{Contrast ratio (CR)} = \frac{\text{Brightness on the "White" state}}{\text{Brightness on the "Black" state}}$$

Note 7 : Definition of Cross Talk (CT)

$$CT = |Y_B - Y_A| / Y_A \times 100 (\%)$$

Where

$Y_A$  = Luminance of measured location without gray level 0 pattern (cd/m<sup>2</sup>)





## Product Specification

AU OPTRONICS CORPORATION

$Y_B$  = Luminance of measured location with gray level 0 pattern (cd/m<sup>2</sup>)

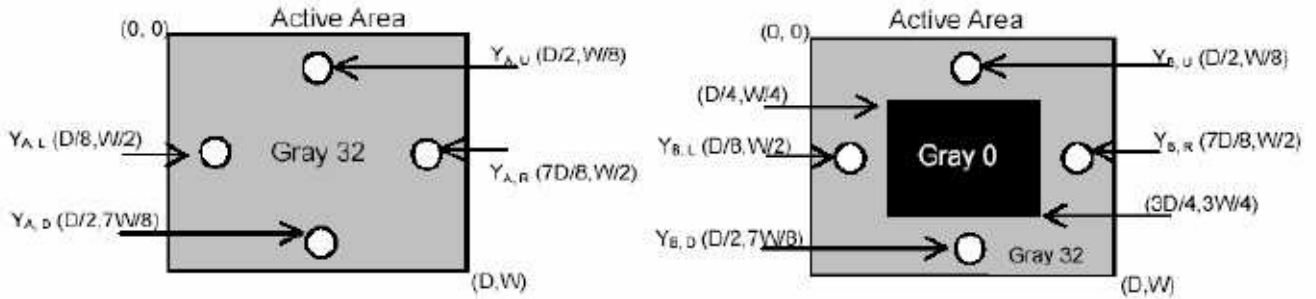

Note 8: Definition of response time:

The output signals of BM-7 or equivalent are measured when the input signals are changed from “Black” to “White” (falling time) and from “White” to “Black” (rising time), respectively. The response time interval between the 10% and 90% of amplitudes. Refer to figure as below.

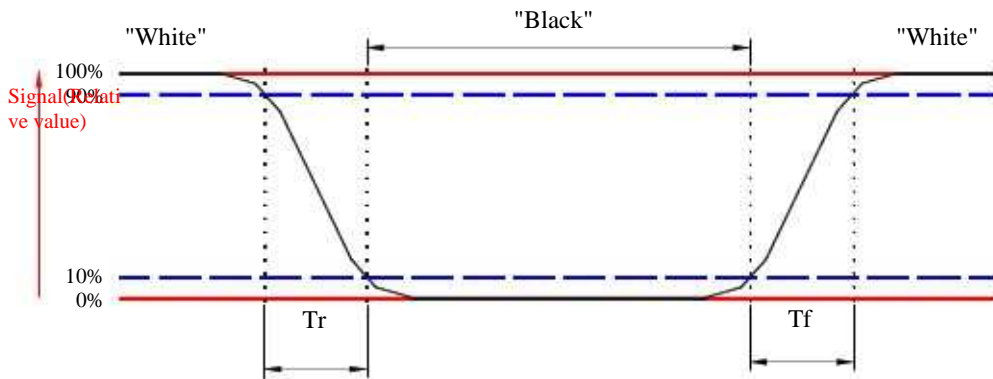



## Product Specification

AU OPTRONICS CORPORATION

### Note 8. Definition of viewing angle

Viewing angle is the measurement of contrast ratio  $\geq 10$ , at the screen center, over a 180° horizontal and 180° vertical range (off-normal viewing angles). The 180° viewing angle range is broken down as follows; 90° ( $\theta$ ) horizontal left and right and 90° ( $\Phi$ ) vertical, high (up) and low (down). The measurement direction is typically perpendicular to the display surface with the screen rotated about its center to develop the desired measurement viewing angle.

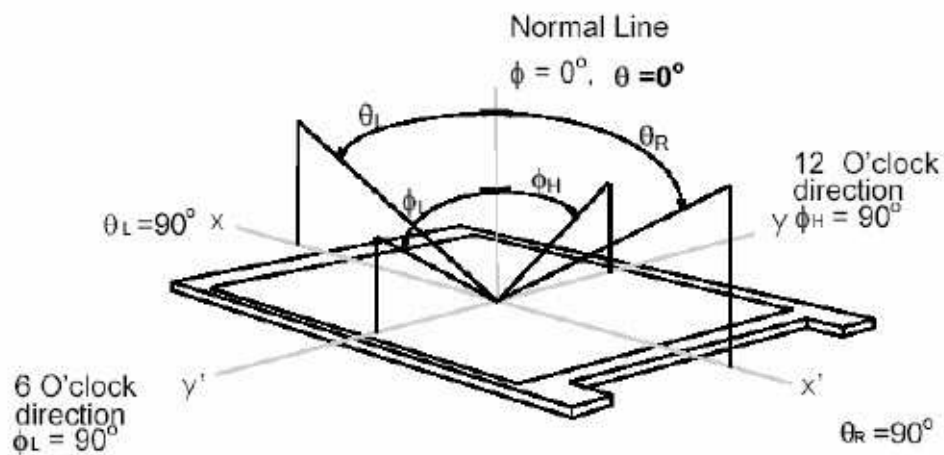



## Product Specification

AU OPTRONICS CORPORATION

### 3. Functional Block Diagram

The following diagram shows the functional block of the 12.1 inches wide Color TFT/LCD Module:

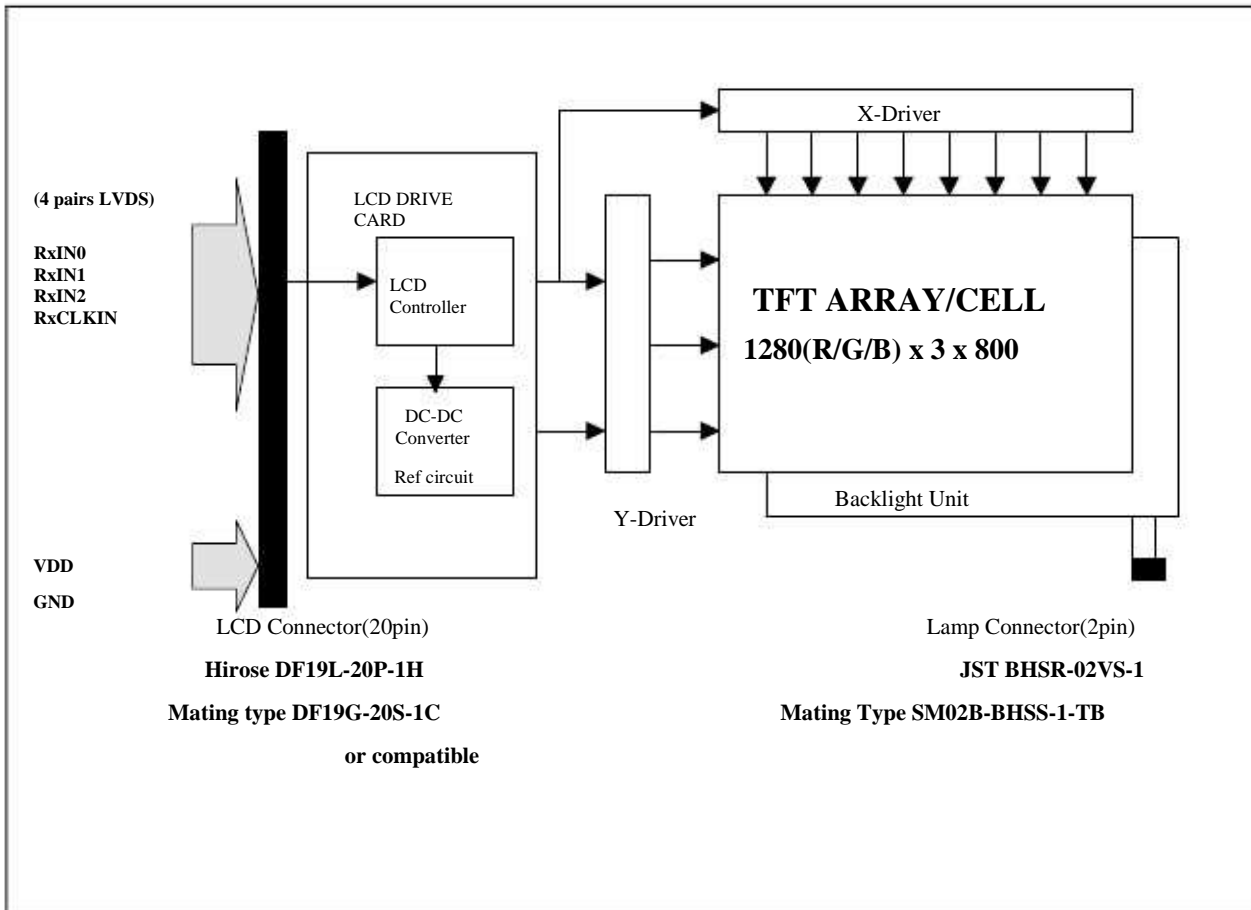



# Product Specification

AU OPTRONICS CORPORATION

## 4. Absolute Maximum Ratings

An absolute maximum rating of the module is as following:

### 4.1 Absolute Ratings of TFT LCD Module

Item	Symbol	Min	Max	Unit	Conditions
Logic/LCD Drive Voltage	Vin	-0.3	+4.0	[Volt]	Note 1,2

### 4.2 Absolute Ratings of Backlight Unit

Item	Symbol	Min	Max	Unit	Conditions
CCFL Current	ICCFL	3.0	7.0	[mA] rms	Note 1,2

### 4.3 Absolute Ratings of Environment

Item	Symbol	Min	Max	Unit	Conditions
Operating Temperature	TOP	0	+50	[°C]	Note 3
Operation Humidity	HOP	5	95	[%RH]	Note 3
Storage Temperature	TST	-20	+60	[°C]	Note 3
Storage Humidity	HST	5	95	[%RH]	Note 3

Note 1: At Ta (25 °C)

Note 2: Permanent damage to the device may occur if exceed maximum values

Note 3: For quality performance, please refer to AUO IIS (Incoming Inspection Standard).

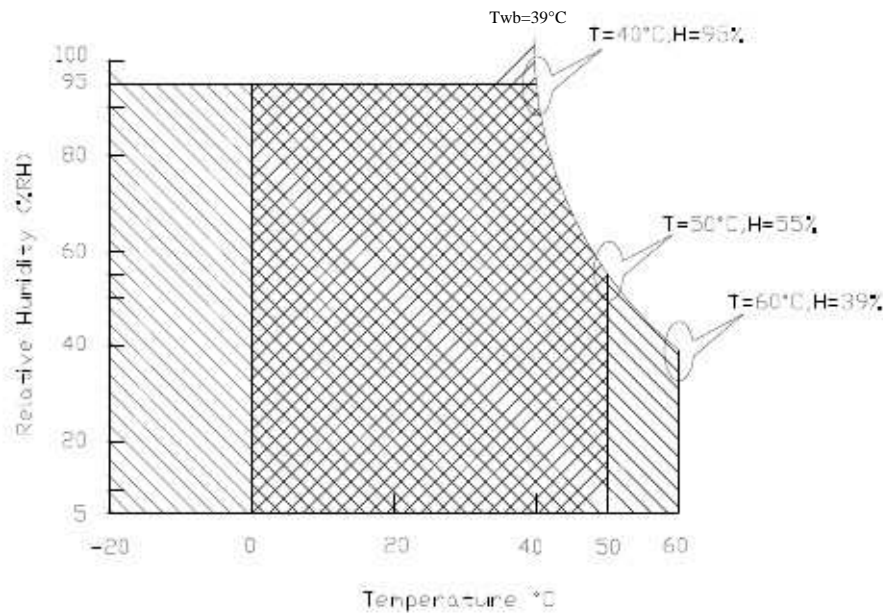

Operating Range



Storage Range

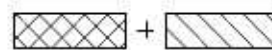



## Product Specification

AU OPTRONICS CORPORATION

### 5. Electrical characteristics

#### 5.1 TFT LCD Module

##### 5.1.1 Power Specification

Input power specifications are as follows;

Symble	Parameter	Min	Typ	Max	Units	Note
VDD	Logic/LCD Drive Voltage	3.0	3.3	3.6	[Volt]	
PDD	VDD Power	-	-	0.8	[Watt]	Note 1/2
IDD	IDD Current	-	222	242	[mA]	Note 1/2
IRush	Inrush Current	-	-	2000	[mA]	Note 3
VDDrp	Allowable Logic/LCD Drive Ripple Voltage	-	-	100	[mV] p-p	

Note 1 : Maximum Measurement Condition

Black Pattern

Note 2 : Typical Measurement Condition: Mosaic Pattern

Note 3 : Measure Condition

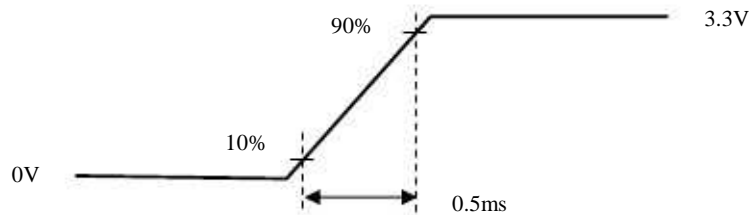
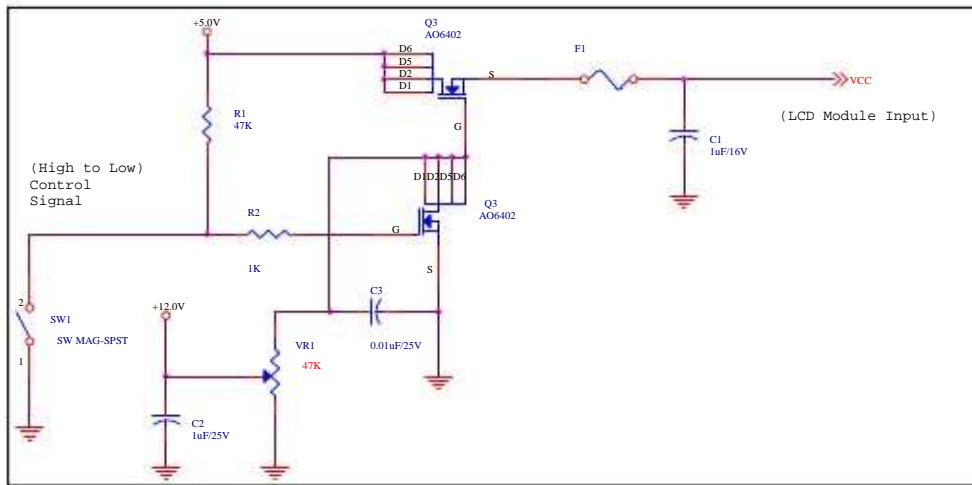

Vin rising time



## Product Specification

AU OPTRONICS CORPORATION

### 5.1.2 Signal Electrical Characteristics

Input signals shall be low or High-impedance state when VDD is off.

It is recommended to refer the specifications of THC63LVDF84A (Thine Electronics Inc.) in detail.

Signal electrical characteristics are as follows;

Parameter	Condition	Min	Max	Unit
V <sub>th</sub>	Differential Input High Threshold (V <sub>cm</sub> =+1.2V)	-	100	[mV]
V <sub>tl</sub>	Differential Input Low Threshold (V <sub>cm</sub> =+1.2V)	-100	-	[mV]
V <sub>cm</sub>	Differential Input Common Mode Voltage	0.4	VCC-1.1	[V]

Note: LVDS Signal Waveform

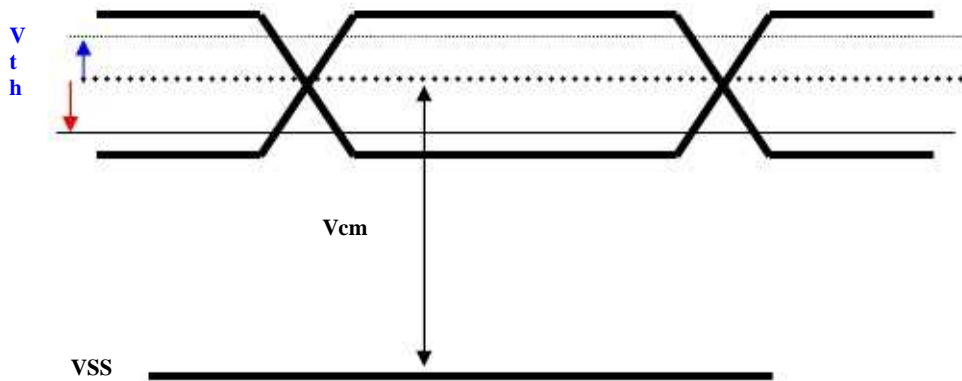



## Product Specification

AU OPTRONICS CORPORATION

### 5.2 Backlight Unit

CCFL Parameter guideline for CCFL Inverter selection (Ref. Remark 1)

Parameter	Min	Typ	Max	Units	Condition
CCFL current(I <sub>CCFL</sub> )	2.0	6.0	7.0	[mA] rms	(Ta=25 ) Note 1
CCFL Frequency(F <sub>CCFL</sub> )	45	62	70	[KHz]	(Ta=25 ) Note 2,3
CCFL startup Voltage(V <sub>s</sub> )			1750	[Volt] rms	(Ta= 0 ) Note 4
CCFL startup Voltage(V <sub>s</sub> )			1460	[Volt] rms	(Ta= 25 ) Note 4
CCFL Voltage (Reference) (V <sub>CCFL</sub> )	522	580	638	[Volt] rms	(Ta=25 ) Note 5
CCFL Power consumption (P <sub>CCFL</sub> )	-	3.5	4.5	[Watt]	(Ta=25 ) Note 5
CCFL Life-Time	12,000	-	-	Hour	(Ta=25 ) Note 7

To optimun TFT LCD performance, the LAMP inverter PWM Frequesncy define as:210 +/-5 Hz

**Remark 1:** Typ are AUO recommended Design Points.

- 1-1 All of characteristics listed are measured under the condition using the AUO Test inverter.
- 1-2 In case of using an inverter other than listed, it is recommended to check the inverter carefully.  
Sometimes, interfering noise stripes appear on the screen, and substandard luminance or flicker at low power may happen.
- 1-3 In designing an inverter, it is suggested to check safety circuit very carefully. Impedance of CCFL, for instance, becomes more than 1 [M ohm] when CCFL is damaged.
- 1-4 Generally, CCFL has some amount of delay time after applying starting voltage. It is recommended to keep on applying starting voltage for **1 [Sec]** until discharge.
- 1-5 CCFL discharge frequency must be carefully chosen so as not to produce interfering noise stripes on the screen.
- 1-6 Reducing CCFL current increases CCFL discharge voltage and generally increases CCFL discharge frequency. So all the parameters of an inverter should be carefully designed so as not to produce too much leakage current from high-voltage output of the inverter.

**Note 1:** It should be employed the inverter which has “Duty Dimming”, if ICCFL is less than 4mA.



## Product Specification

AU OPTRONICS CORPORATION

**Note 2:** CCFL discharge frequency should be carefully determined to avoid interference between inverter and TFT LCD.

**Note 3:** The frequency range will not affect to lamp life and reliability characteristics.

**Note 4:** The output voltage of inverter should be able to give out a power after ballast capacitor, the generating capacity have to be larger than a lamp startup voltage, otherwise backlight may has blinking for a moment after turns on or can not be turned on.

**Note 5:** Calculator value for reference ( $IC_{CFL} \times V_{CCFL} = P_{CCFL}$ )

**Note 6:** Requirements for a system inverter design, which is intended to have a better display performance, a better power efficiency and a more reliable lamp, are following.

It shall help increase the lamp lifetime and reduce leakage current.

- The asymmetry rate of the inverter waveform should be less than 10%.
- The distortion rate of the waveform should be within  $\sqrt{2} \pm 10\%$ .

\* Inverter output waveform had better be more similar to ideal sine wave.

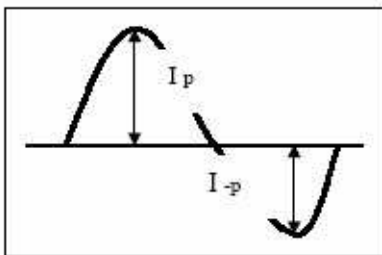

\* Asymmetry rate:

$$\frac{|I_p - I_{-p}|}{I_{rms}} * 100\%$$

\* Distortion rate

$$I_p \text{ (or } I_{-p}) / I_{rms}$$

**Note 7:** It is an edge-type BLU with single CCFL, the life-time define as the brightness decay to 50% of original value and under normal operation.





# Product Specification

AU OPTRONICS CORPORATION

## 6. Signal Characteristic

### 6.1 Pixel Format Image

Following figure shows the relationship of the input signals and LCD pixel format.

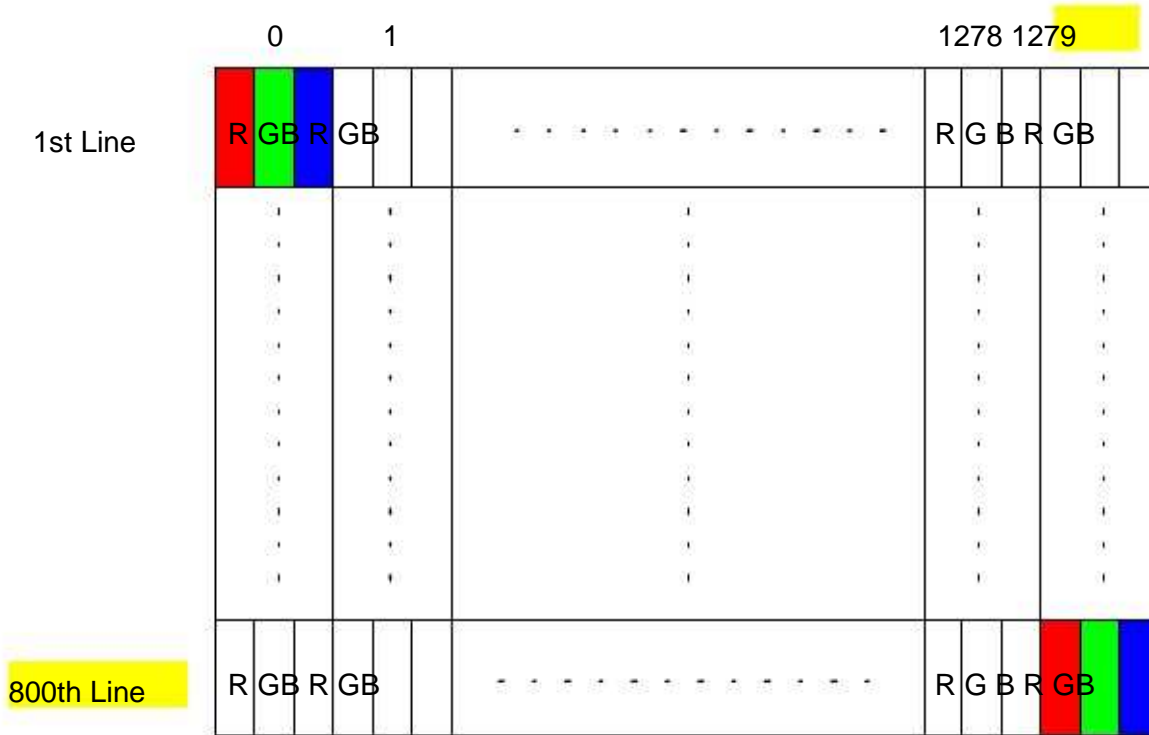



## Product Specification

AU OPTRONICS CORPORATION

### 6.2 The input data format

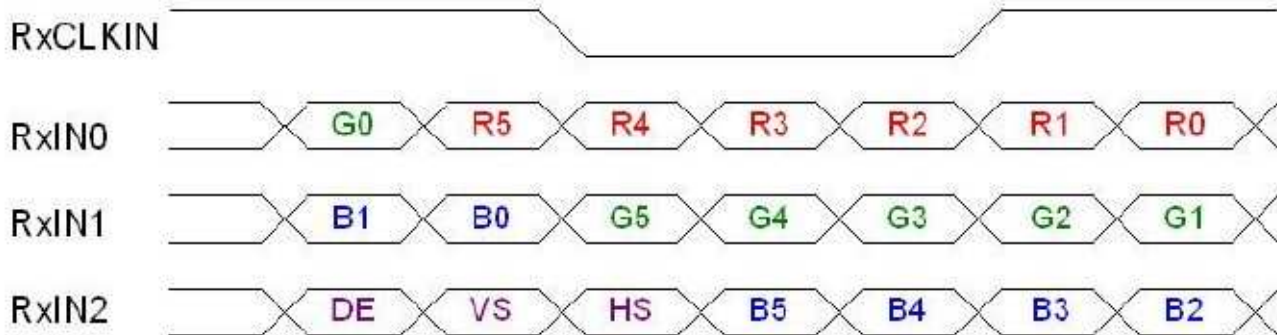

Signal Name	Description	
R5 R4 R3 R2 R1 R0	Red Data 5 (MSB) Red Data 4 Red Data 3 Red Data 2 Red Data 1 Red Data 0 (LSB)	Red-pixel Data Each red pixel's brightness data consists of these 6 bits pixel data.
G5 G4 G3 G2 G1 G0	Green Data 5 (MSB) Green Data 4 Green Data 3 Green Data 2 Green Data 1 Green Data 0 (LSB)	Green-pixel Data Each green pixel's brightness data consists of these 6 bits pixel data.
B5 B4 B3 B2 B1 B0	Blue Data 5 (MSB) Blue Data 4 Blue Data 3 Blue Data 2 Blue Data 1 Blue Data 0 (LSB)	Blue-pixel Data Each blue pixel's brightness data consists of these 6 bits pixel data.
RxCLKIN	Data Clock	The typical frequency is 71.1 MHZ.. The signal is used to strobe the pixel data and DE signals. All pixel data shall be valid at the falling edge when the DE signal is high.
DE	Display Timing	This signal is strobed at the falling edge of RxCLKIN. When the signal is high, the pixel data shall be valid to be displayed. The signal is synchronized to RxCLKIN .
VS	Vertical Sync	The signal is synchronized to RxCLKIN .
HS	Horizontal Sync	

Note: Output signals from any system shall be low or High-impedance state when VDD is off.



## Product Specification

AU OPTRONICS CORPORATION

### 6.3 Signal Description/Pin Assignment

LVDS is a differential signal technology for LCD interface and high speed data transfer device.

Pin#	Signal Name	Pin#	Signal Name
1	GND	2	VDD
3	VDD	4	VDD <sub>EDID</sub>
5	AGING	6	CLK <sub>EDID</sub>
7	DATA <sub>EDID</sub>	8	RxIN0N
9	RxIN0P	10	GND
11	RxIN1N	12	RxIN1P
13	GND	14	RxIN2N
15	RxIN2P	16	GND
17	RxCLKINN	18	RxCLKINP
19	GND	20	GND



# Product Specification

AU OPTRONICS CORPORATION

Note1: Start from right side

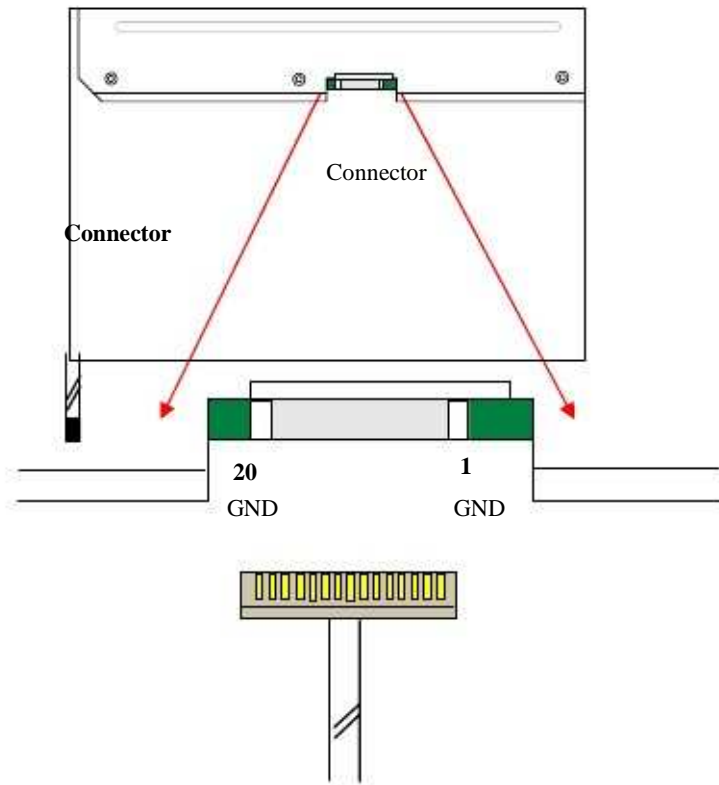

Note2: Input signals shall be low or High-impedance state when VDD is off.



## Product Specification

AU OPTRONICS CORPORATION

internal circuit of LVDS inputs are as following.

The module uses a 100ohm resistor between positive and negative data lines of each receiver input

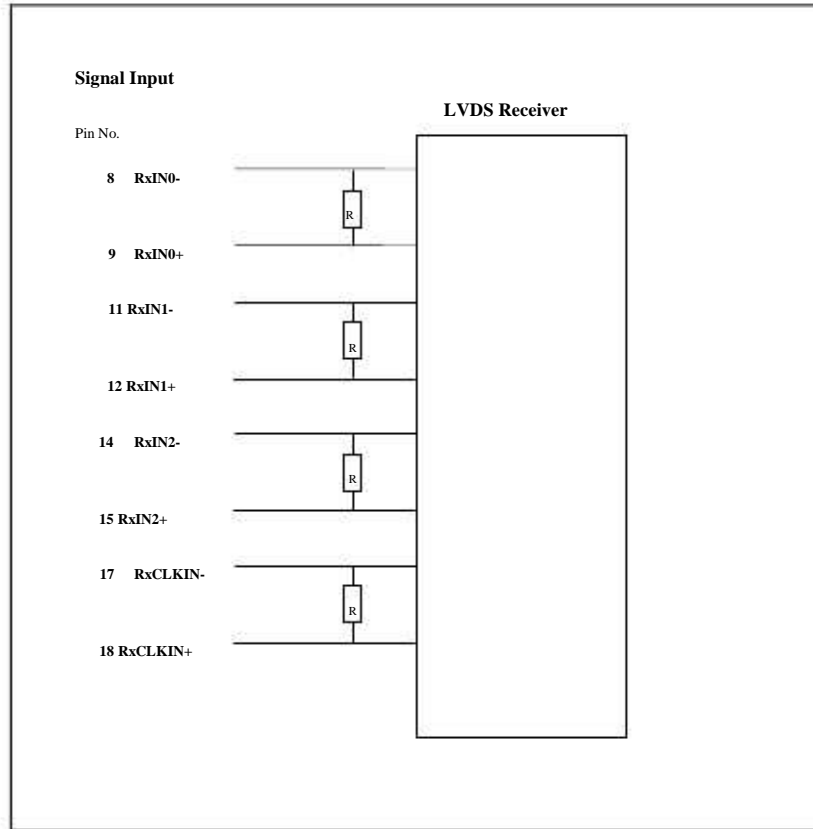



## Product Specification

AU OPTRONICS CORPORATION

### 6.4 Interface Timing

#### 6.4.1 Timing Characteristics

Basically, interface timings should match the 1280x800 /60Hz manufacturing guide line timing.

Parameter	Symbol	Min.	Typ.	Max.	Unit	
Frame Rate	-	-	60	-	Hz	
Clock frequency	1/ T <sub>clock</sub>	-	71.1	-	MHz	
Vertical Section	Period	T <sub>V</sub>	-	823	-	T <sub>Line</sub>
	Active	T <sub>VD</sub>	-	800	-	
	Blanking	T <sub>VB</sub>	-	23	-	
Horizontal Section	Period	T <sub>H</sub>	-	1440	-	T <sub>clock</sub>
	Active	T <sub>HD</sub>	-	1280	-	
	Blanking	T <sub>HB</sub>	-	160	-	

Note : DE mode only



# Product Specification

AU OPTRONICS CORPORATION

## 6.4.2 Timing diagram

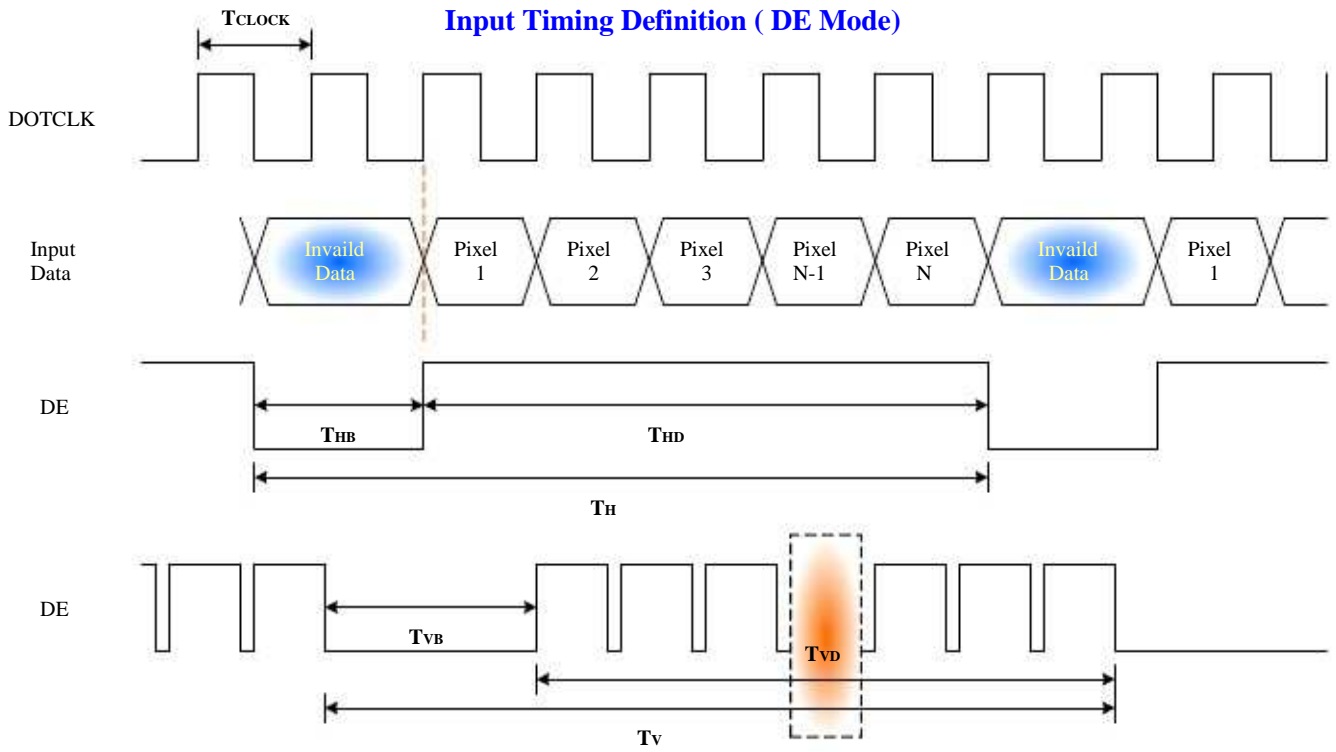



## Product Specification

AU OPTRONICS CORPORATION

### 6.5 Power ON/OFF Sequence

VDD power and lamp on/off sequence is as follows. Interface signals are also shown in the chart. Signals from any system shall be Hi-Z state or low level when VDD is off.

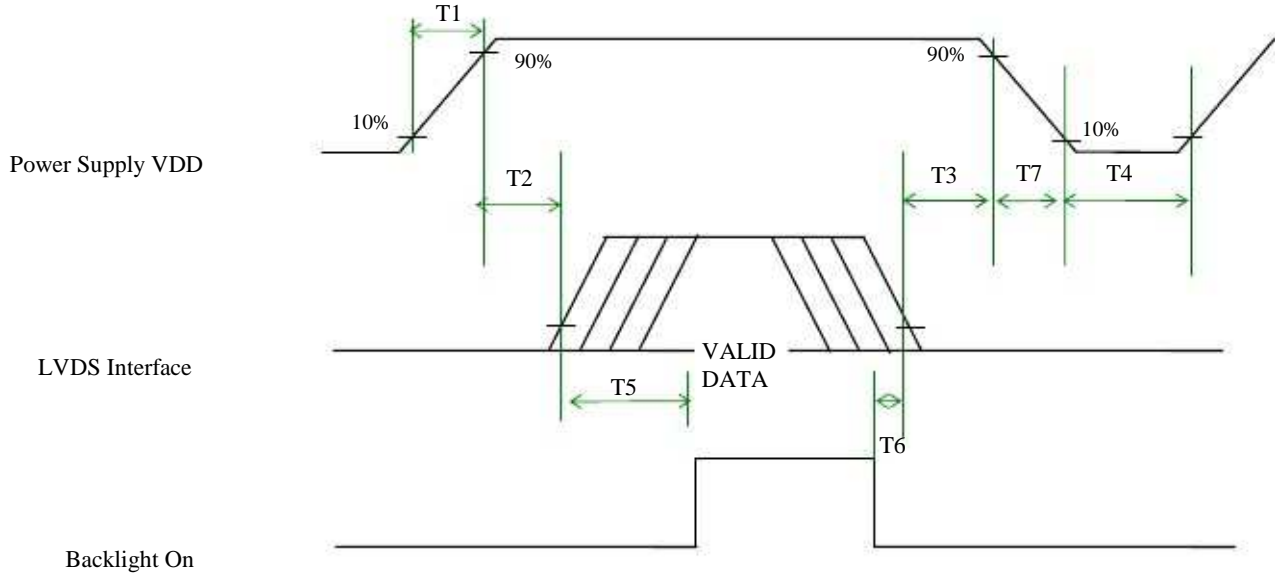

#### Power Sequence Timing

Parameter	Value			Units
	Min.	Typ.	Max.	
T1	0.5	-	10	(ms)
T2	0	-	50	(ms)
T3	0	-	50	(ms)
T4	400	-	-	(ms)
T5	200	-	-	(ms)
T6	200	-	-	(ms)
T7	0	-	10	(ms)





## Product Specification

AU OPTRONICS CORPORATION

### 7. Connector Description

Physical interface is described as for the connector on module.

These connectors are capable of accommodating the following signals and will be following components.

#### 7.1 TFT LCD Module

Connector Name / Designation	For Signal Connector
Manufacturer	Hirose
Type / Part Number	DF19LA-20P-1H
Mating Housing/Part Number	MSB24013P20A or compatible

#### 7.2 Backlight Unit

Physical interface is described as for the connector on module.

These connectors are capable of accommodating the following signals and will be following components.

Connector Name / Designation	For Lamp Connector
Manufacturer	JST
Type / Part Number	BHSR-02VS-1
Mating Type / Part Number	SM02B-BHSS-1-TB

#### 7.3 Signal for Lamp connector

Pin #	Cable color	Signal Name
1	Pink	Lamp High Voltage
2	White	Lamp Low Voltage



## Product Specification

AU OPTRONICS CORPORATION

### 8. Dynamic Test

#### 8.1 Vibration Test

**Test condition:**

Acceleration: 1.5 G  
Frequency: 10 - 500Hz Random  
Sweep: 30 Minutes each Axis (X, Y, Z)

#### 8.2 Shock Test Spec:

**Test condition:**

Acceleration: 220 G , Half sine wave  
Active time: 2 ms  
Pulse: +/-X, +/-Y, +/-Z , one time for each side

**Remark:**

1. Ambient condition is 25 ± 5 , Relative humidity : 40% ~ 70%
2. Non-packaged and Non-operation 



## Product Specification

AU OPTRONICS CORPORATION

### 9. Reliability

Items	Required Condition	Note
Temperature Humidity Bias	Ta= 40□, 90%RH, 300h□	
High Temperature Operation	Ta= 50□, Dry, 300h□	
Low Temperature Operation	Ta= 0□, 300h□	
High Temperature Storage	Ta= 60□, 35%RH, 300h□	
Low Temperature Storage	Ta= -20□, 50%RH, 300h□	
Thermal Shock Test	Ta=-20□ to 60□, Duration at 30 min, 100 cycles□□	
ESD	Contact : ±8 KV Air : ±15 KV	Note 1

**Note1:** According to EN 61000-4-2 , ESD class B: Some performance degradation allowed. No data lost

. Self-recoverable. No hardware failures.

**Remark:** MTBF (Excluding the CCFL): 30,000 hours with a confidence level 90%



# Product Specification

AU OPTRONICS CORPORATION

## 10. Mechanical Characteristics

### 10.1 LCM Outline Dimension

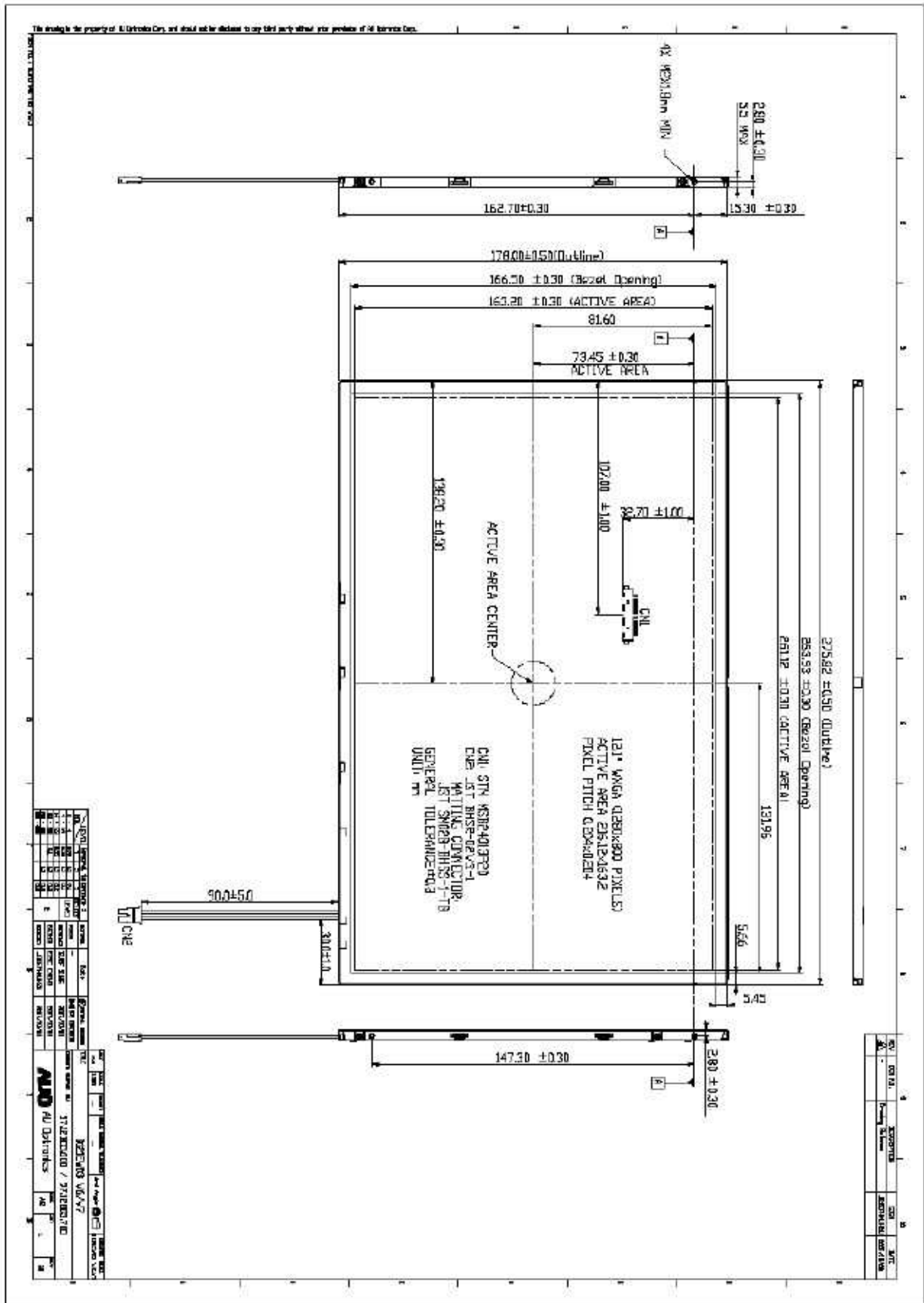



# Product Specification

AU OPTRONICS CORPORATION

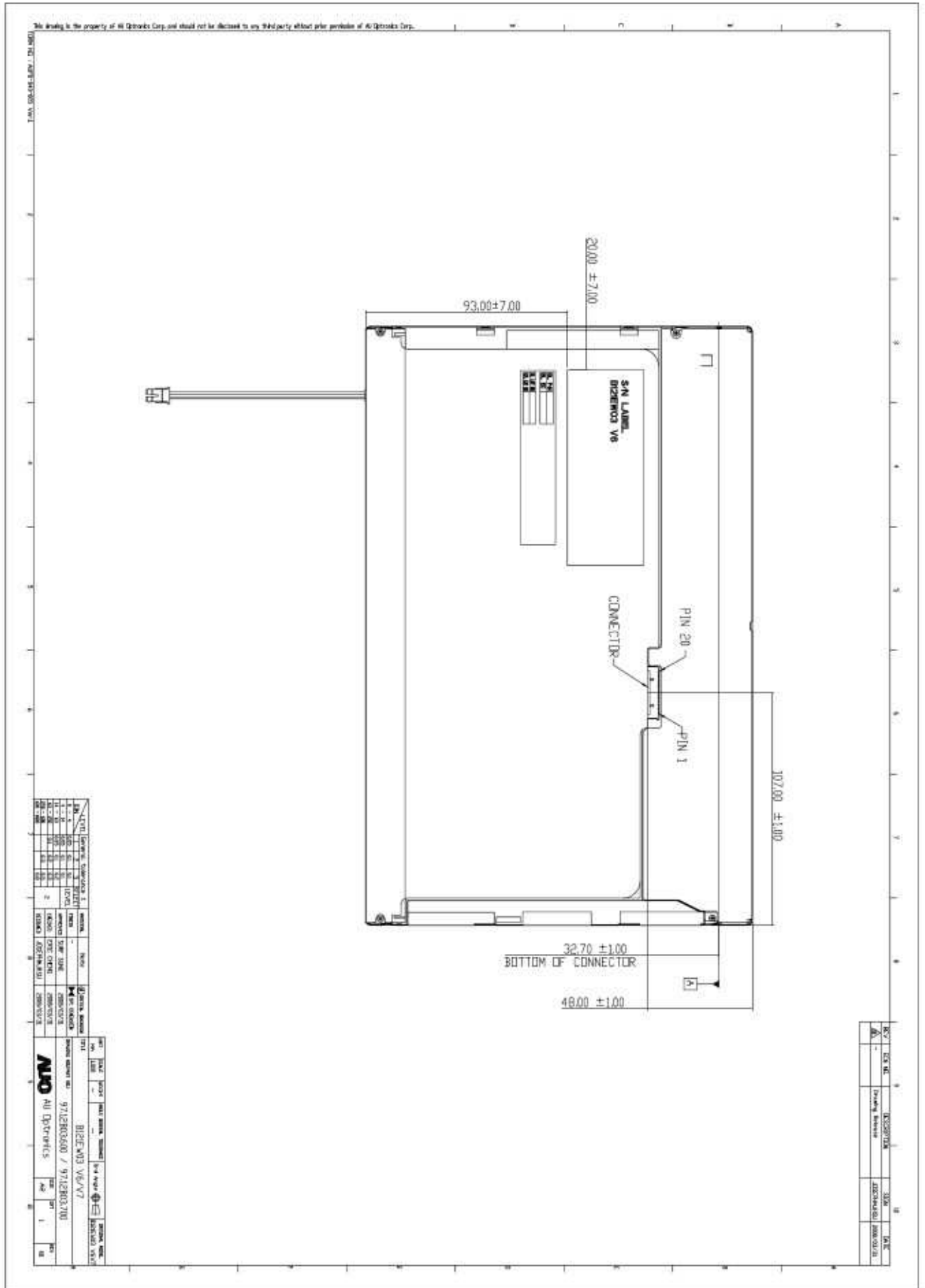



## Product Specification

AU OPTRONICS CORPORATION

### 10.2 Screw Hole Depth and Center Position

Screw hole minimum depth, from side surface = 1.80 mm (Ref. drawing)

Screw hole center location, from front surface =  $2.8 \pm 0.2$ mm (Ref. drawing)

Screw Torque: Maximum 2.2 kgf-cm

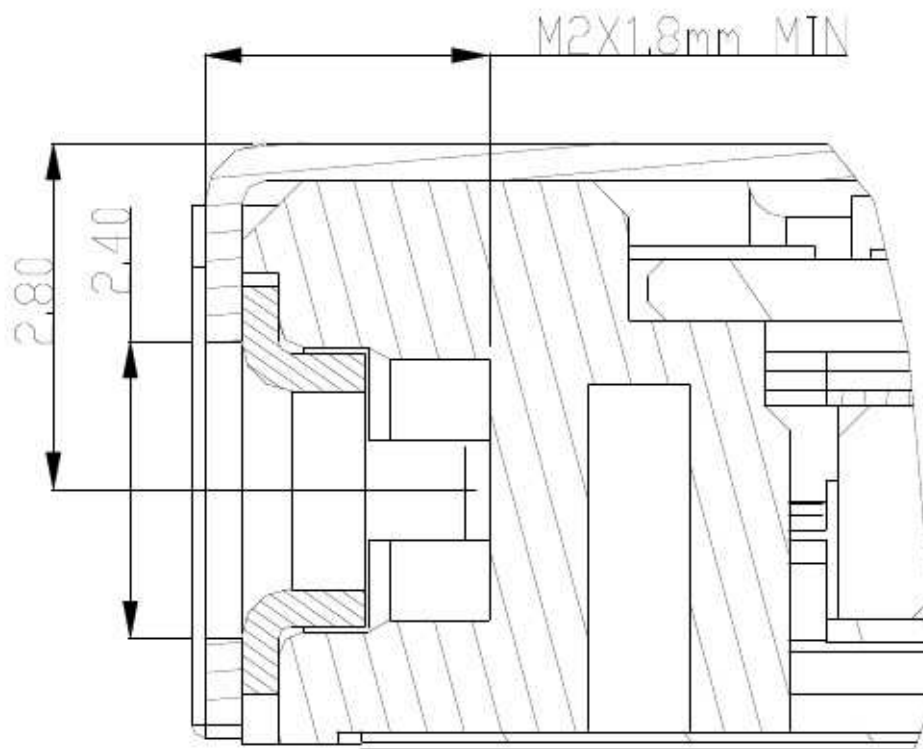



# Product Specification

AU OPTRONICS CORPORATION

## 11. Shipping and Package

### 11.1 Shipping Label Format

 =XXXXXXXXXXXX-XXXXX=	Manufactured <b>MMWW</b> Model No: <b>B121EW03</b> AU Optronics	<b>V.6</b> <b>1AXXG</b>	 XXXXXX	
 CT:XXXXXXXXXX	<b>HW: 1A FW:1</b>			



## Product Specification

AU OPTRONICS CORPORATION

### 11.2 Carton package

The outside dimension of carton is 455 (L)mm x 380 (W)mm x 355 (H)mm

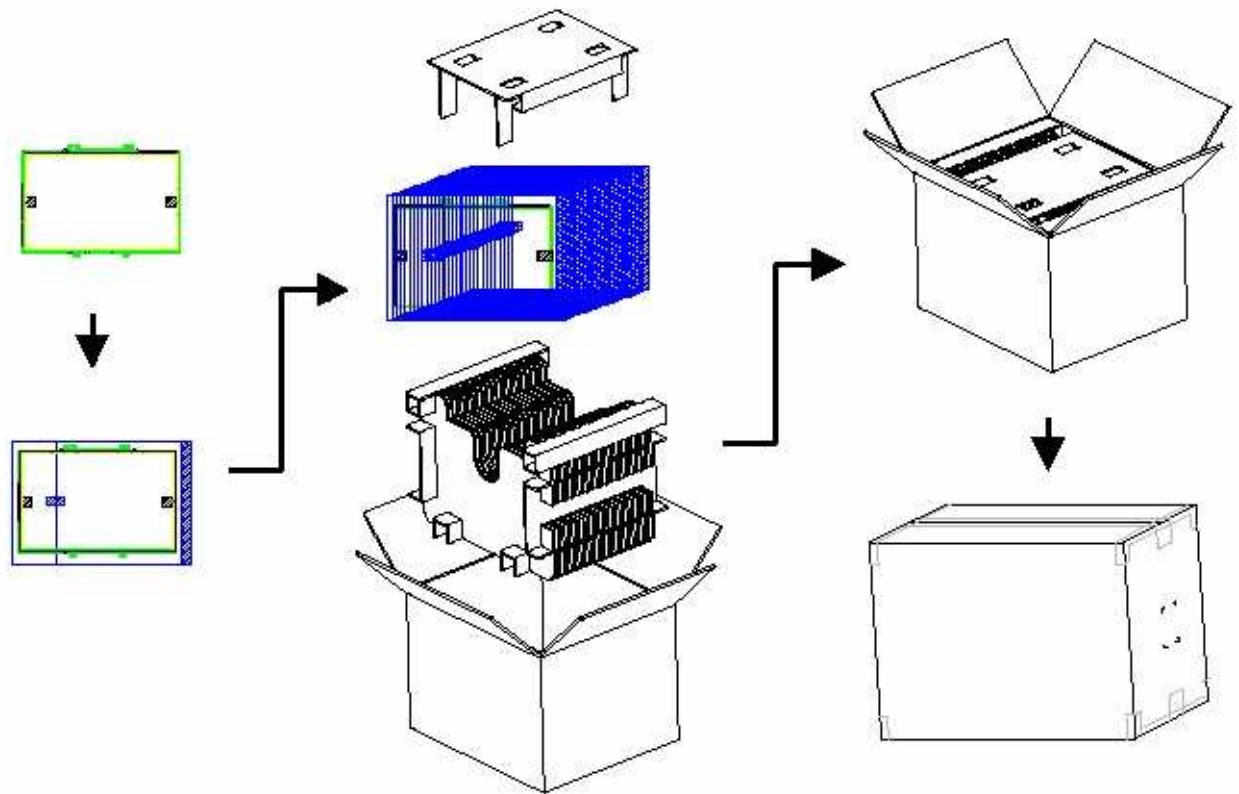

### 11.3 Shipping package of palletizing sequence

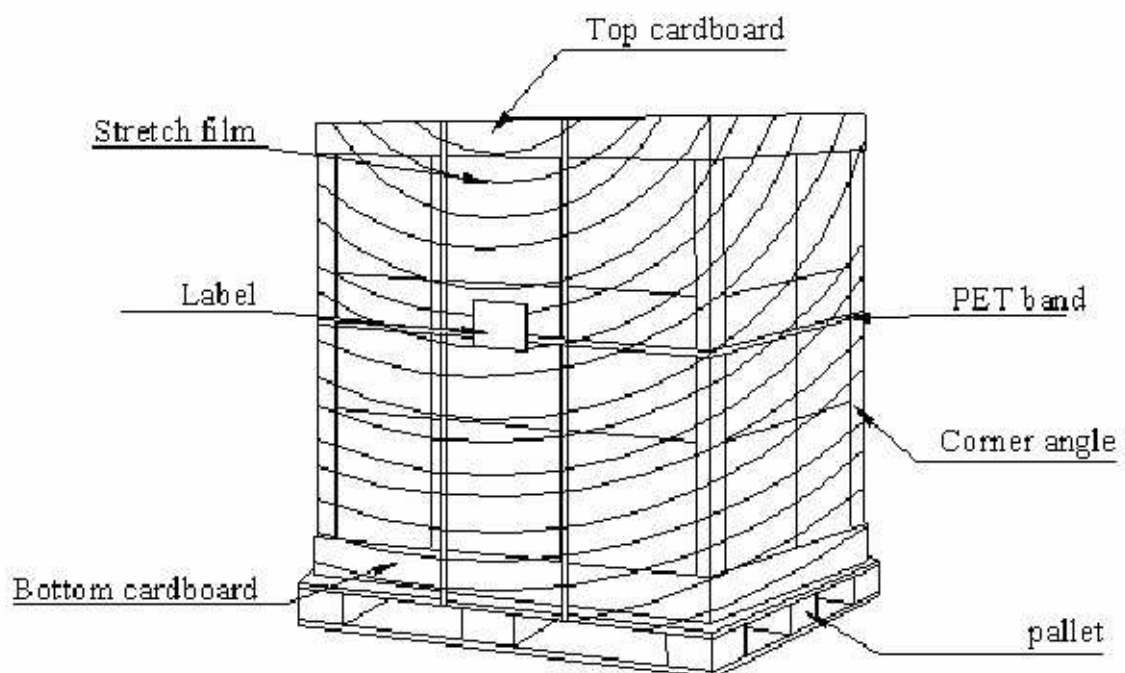





## Product Specification

AU OPTRONICS CORPORATION

### 12. Appendix: EDID description

Address	FUNCTION	Value	Value	Value
HEX		HEX	BIN	DEC
00	Header	00	00000000	0
01		FF	11111111	255
02		FF	11111111	255
03		FF	11111111	255
04		FF	11111111	255
05		FF	11111111	255
06		FF	11111111	255
07		00	00000000	0
08	EISA Manuf. Code LSB	06	00000110	6
09	Compressed ASCII	AF	10101111	175
0A	Product Code	14	00010100	20
0B	Serial BSL, xeh	36	00110110	54
0C	EDID Vendor ID	00	00000000	0
0D	32-bit ser #	00	00000000	0
0E		00	00000000	0
0F		00	00000000	0
10	Week of manufacture	01	00000001	1
11	Year of manufacture	11	00010001	17
12	EDID Structure Ver.	01	00000001	1
13	EDID revision #	03	00000011	3
14	<b>Video input def.</b> (digital I/P, non-TMDS, CRGB)	80	10000000	128
15	<b>Max H image size</b> (rounded to cm)	1A	00011010	26
16	<b>Max V image size</b> (rounded to cm)	10	00010000	16
17	<b>Display Gamma</b> $(=(\text{gamma} \times 100) - 100)$	78	01111000	120
18	<b>Feature support</b> (no DPMS, Active OFF, RGB, tmg Blk#1)	0A	00001010	10
19	Red/green low bits ( <b>Lower 2:2:2:2 bits</b> )	87	10000111	135
1A	Blue/white low bits ( <b>Lower 2:2:2:2 bits</b> )	F5	11110101	245
1B	Red x ( <b>Upper 8 bits</b> )	94	10010100	148
1C	Red y/ highER 8 bits	57	01010111	87
1D	Green x	4F	01001111	79
1E	Green y	8C	10001100	140
1F	Blue x	27	00100111	39
20	Blue y	27	00100111	39
21	White x	50	01010000	80
22	White y	54	01010100	84
23	Established timing 1	00	00000000	0
24	Established timing 2	00	00000000	0
25	Established timing 3	00	00000000	0
26	Standard timing #1	01	00000001	1
27		01	00000001	1
28	Standard timing #2	01	00000001	1
29		01	00000001	1
2A	Standard timing #3	01	00000001	1
2B		01	00000001	1



## Product Specification

AU OPTRONICS CORPORATION

2C	Standard timing #4	01	00000001	1
2D		01	00000001	1
2E	Standard timing #5	01	00000001	1
2F		01	00000001	1
30	Standard timing #6	01	00000001	1
31		01	00000001	1
32	Standard timing #7	01	00000001	1
33		01	00000001	1
34	Standard timing #8	01	00000001	1
35		01	00000001	1
36	Pixel Clock/10000 LSB	C7	11000111	199
37	Pixel Clock/10000 USB	1B	00011011	27
38	Horz active <b>Lower 8bits</b>	00	00000000	0
39	Horz blanking <b>Lower 8bits</b>	A0	10100000	160
3A	HorzAct:HorzBlnk <b>Upper 4:4 bits</b>	50	01010000	80
3B	Vertical Active <b>Lower 8bits</b>	20	00100000	32
3C	Vertical Blanking <b>Lower 8bits</b>	17	00010111	23
3D	Vert Act : Vertical Blanking <b>(upper 4:4 bit)</b>	30	00110000	48
3E	HorzSync. Offset	30	00110000	48
3F	HorzSync.Width	20	00100000	32
40	VertSync.Offset : VertSync.Width	36	00110110	54
41	Horz&Vert Sync Offset/Width <b>Upper 2bits</b>	00	00000000	0
42	Horizontal Image Size <b>Lower 8bits</b>	05	00000101	5
43	Vertical Image Size <b>Lower 8bits</b>	A3	10100011	163
44	Horizontal & Vertical Image Size <b>(upper 4:4 bits)</b>	10	00010000	16
45	Horizontal Border (zero for internal LCD)	00	00000000	0
46	Vertical Border (zero for internal LCD)	00	00000000	0
47	Signal (non-intr, norm, no stereo, sep sync, neg pol)	18	00011000	24
48	Detailed timing/monitor	00	00000000	0
49	descriptor #2	00	00000000	0
4A		00	00000000	0
4B		0F	00001111	15
4C		00	00000000	0
4D		00	00000000	0
4E		00	00000000	0
4F		00	00000000	0
50		00	00000000	0
51		00	00000000	0
52		00	00000000	0
53		00	00000000	0
54		00	00000000	0
55		00	00000000	0
56		00	00000000	0
57		00	00000000	0
58		00	00000000	0
59		20	00100000	32
5A	Detailed timing/monitor	00	00000000	0



## Product Specification

AU OPTRONICS CORPORATION

5B	descriptor #3	00	00000000	0
5C		00	00000000	0
5D		FE	11111110	254
5E		00	00000000	0
5F	Manufacture	41	01000001	65
60	Manufacture	55	01010101	85
61	Manufacture	4F	01001111	79
62		0A	00001010	10
63		20	00100000	32
64		20	00100000	32
65		20	00100000	32
66		20	00100000	32
67		20	00100000	32
68		20	00100000	32
69		20	00100000	32
6A		20	00100000	32
6B		20	00100000	32
6C	Detailed timing/monitor	00	00000000	0
6D	descriptor #4	00	00000000	0
6E		00	00000000	0
6F		FE	11111110	254
70		00	00000000	0
71	Manufacture P/N	42	01000010	66
72	Manufacture P/N	31	00110001	49
73	Manufacture P/N	32	00110010	50
74	Manufacture P/N	31	00110001	49
75	Manufacture P/N	45	01000101	69
76	Manufacture P/N	57	01010111	87
77	Manufacture P/N	30	00110000	48
78	Manufacture P/N	33	00110011	51
79	Manufacture P/N	20	00100000	32
7A	Manufacture P/N	56	01010110	86
7B	Manufacture P/N	36	00110110	54
7C		20	00100000	32
7D		0A	00001010	10
7E	Extension Flag	00	00000000	0
7F	Checksum	D	00001101	13