



Product Specification

B121EW10 V0

() Preliminary Specifications

() Final Specifications

Module	12.1" WXGA Color TFT-LCD
Model Name	B121EW10 V0 (97.12B10.000/001)

Customer	Date
_____	_____
Checked & Approved by	
_____	_____
Note: This Specification is subject to change without notice.	

Approved by	Date
Ivy Lee	2009/2/25
Prepared by	
Emily Chen	2009/2/25
NBBU Marketing Division / AU Optronics corporation	

Contents

1. Handling Precautions	4
2. General Description	5
2.1 General Specification.....	5
2.2 Optical Characteristics.....	6
3. Functional Block Diagram	11
4. Absolute Maximum Ratings	12
4.1 Absolute Ratings of TFT LCD Module	12
4.2 Absolute Ratings of Backlight Unit.....	12
4.3 Absolute Ratings of Environment.....	12
5. Electrical characteristics	13
5.1 TFT LCD Module	13
5.2 Backlight Unit.....	14
6. Signal Characteristic	16
6.1 Pixel Format Image.....	16
6.2 The input data format.....	17
6.3 Signal Description/Pin Assignment	18
6.4 Interface Timing	21
6.5 Power ON/OFF Sequence.....	22
7. Connector Description	23
8. Vibration and Shock Test	24
8.1 Vibration Test	24
8.2 Shock Test Spec:	24
9. Reliability	25
10. Mechanical Characteristics	26
11. Shipping and Package	28
11.1 Shipping Label Format.....	28
11.2. Carton package.....	30
11.3 Shipping package of palletizing.....	30
12. Appendix: EDID description	31



Product Specification

B121EW10 V0

Record of Revision

Version and Date	Page	Old description	New Description	Remark
0.1 2009/2/25	All	First Edition for Customer		

www.yslcd.com.tw

1. Handling Precautions

- 1) Since front polarizer is easily damaged, pay attention not to scratch it.
- 2) Be sure to turn off power supply when inserting or disconnecting from input connector.
- 3) Wipe off water drop immediately. Long contact with water may cause discoloration or spots.
- 4) When the panel surface is soiled, wipe it with absorbent cotton or other soft cloth.
- 5) Since the panel is made of glass, it may break or crack if dropped or bumped on hard surface.
- 6) Since CMOS LSI is used in this module, take care of static electricity and insure human earth when handling.
- 7) Do not open nor modify the Module Assembly.
- 8) Do not press the reflector sheet at the back of the module to any directions.
- 9) In case if a Module has to be put back into the packing container slot after once it was taken out from the container, do not press the center of the LED Reflector edge. Instead, press at the far ends of the CFL Reflector edge softly. Otherwise the TFT Module may be damaged.
- 10) At the insertion or removal of the Signal Interface Connector, be sure not to rotate nor tilt the Interface Connector of the TFT Module.
- 11) After installation of the TFT Module into an enclosure (Notebook PC Bezel, for example), do not twist nor bend the TFT Module even momentary. At designing the enclosure, it should be taken into consideration that no bending/twisting forces are applied to the TFT Module from outside. Otherwise the TFT Module may be damaged.
- 12) Small amount of materials having no flammability grade is used in the LCD module. The LCD module should be supplied by power complied with requirements of Limited Power Source (IEC60950 or UL1950), or be applied exemption.
- 13) Disconnecting power supply before handling LCD modules, it can prevent electric shock, DO NOT TOUCH the electrode parts, cables, connectors and LED circuit part of TFT module that a LED light bar build in as a light source of back light unit. It can prevent electrostatic breakdown.

2. General Description

B121EW10 V0 is a Color Active Matrix Liquid Crystal Display composed of a TFT LCD panel, a driver circuit, and LED backlight system. The screen format is intended to support the WXGA (1280(H) x 800(V)) screen and 262k colors (RGB 6-bits data driver) with LED backlight driving circuit. All input signals are LVDS interface compatible.

2.1 General Specification

The following items are characteristics summary on the table at 25 °C condition:

Items	Unit	Specifications			
Screen Diagonal	[mm]	307.9 (12.1 W")			
Active Area	[mm]	261.12 (H) x 163.2 (V)			
Pixels H x V		1280x3(RGB) x 800			
Pixel Pitch	[mm]	0.204			
Pixel Arrangement		R.G.B. Vertical Stripe			
Display Mode		Normally White			
White Luminance (ILED=20.0mA) Note: ILED is lamp current	[cd/m ²]	450 Typ. (5 points average) 380 Min. (5 points average) (Note1)			
Luminance Uniformity		1.25 max. (5 points)			
Contrast Ratio		600:1 Typ., 500:1 Min.			
Optical Rise Time/Fall Time	[msec]	16 Typ., 25 Max.			
Nominal Input Voltage VDD	[Volt]	+3.3 Typ.			
Power Consumption	[Watt]	5.5 Max. (Including logic and BLU power, with LED circuit loss) @ 20.0 mA			
Weight (w/o Inverter)	[Grams]	240g Max.			
Physical Size	[mm]		L	W	T
		Max	294.1	182.9	5.1
		Typ	293.6	182.4	-
		min	293.1	181.9	-
Electrical Interface		1 channel LVDS			
Surface Treatment		Anti-galre, 3H			
Support Color		262K colors (RGB 6-bit)			
Temperature Range Operating Storage (Non-Operating)	[°C] [°C]	0 to +50 -20 to +60			
RoHS Compliance		RoHS Compliance			

2.2 Optical Characteristics

The optical characteristics are measured under stable conditions at 25°C (Room Temperature):

Item	Unit	Conditions	Min.	Typ.	Max.	Note
White Luminance ILED=20.0mA	[cd/m ²]	5 points average	380	450	-	1, 4, 5.
Viewing Angle	[degree] [degree]	Horizontal (Right) CR = 10 (Left)	70	80	-	8
			70	80	-	
	Vertical (Upper) CR = 10 (Lower)	70	80	-		
		70	80	-		
Luminance Uniformity		5 Points			1.25	1
Luminance Uniformity		13 Points			1.80	2
CR: Contrast Ratio			500	600	-	6
Cross talk	%				1.4	7
Response Time	[msec]	Rising	-	9	-	8
	[msec]	Falling	-	7	-	
	[msec]	Rising + Falling		16	25	
Color / Chromaticity Coordinates (CIE 1931)		Red x	0.565	0.595	0.625	2,8
		Red y	0.315	0.345	0.375	
		Green x	0.305	0.335	0.365	
		Green y	0.55	0.58	0.61	
		Blue x	0.125	0.155	0.185	
		Blue y	0.105	0.135	0.165	
		White x	0.283	0.313	0.343	
		White y	0.299	0.329	0.359	
NTSC	[%]	CIE 1931	-	45	-	

Note 1: 5 points position (Display area: 261.12 (H) x 163.2 (V) mm)

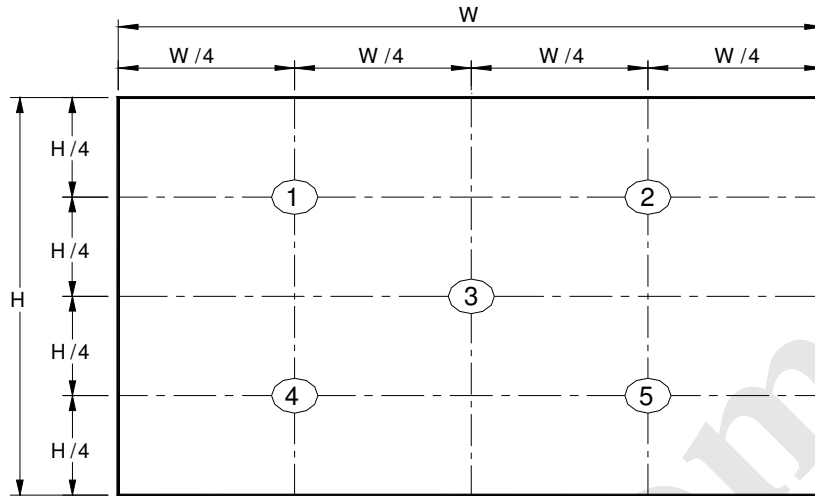

Note 2: 13 points position

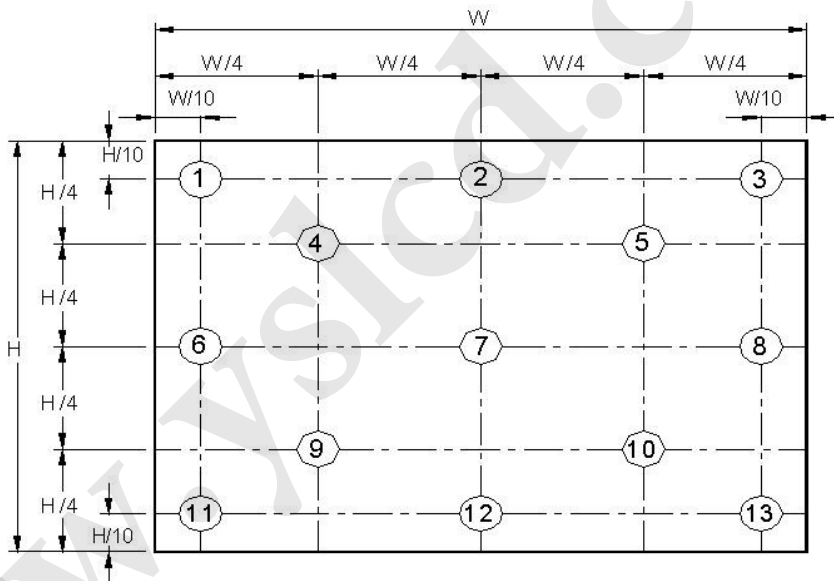

Note 3: The luminance uniformity of 5 and 13 points is defined by dividing the maximum luminance values by the minimum test point luminance

$$\delta_{w5} = \frac{\text{Maximum Brightness of five points}}{\text{Minimum Brightness of five points}}$$

$$\delta_{w13} = \frac{\text{Maximum Brightness of thirteen points}}{\text{Minimum Brightness of thirteen points}}$$

Note 4: Measurement method

The LCD module should be stabilized at given temperature for 30 minutes to avoid abrupt temperature change during measuring. In order to stabilize the luminance, the measurement should be executed after lighting Backlight for 30 minutes in a stable, windless and dark room, and it should be measured in the center of screen

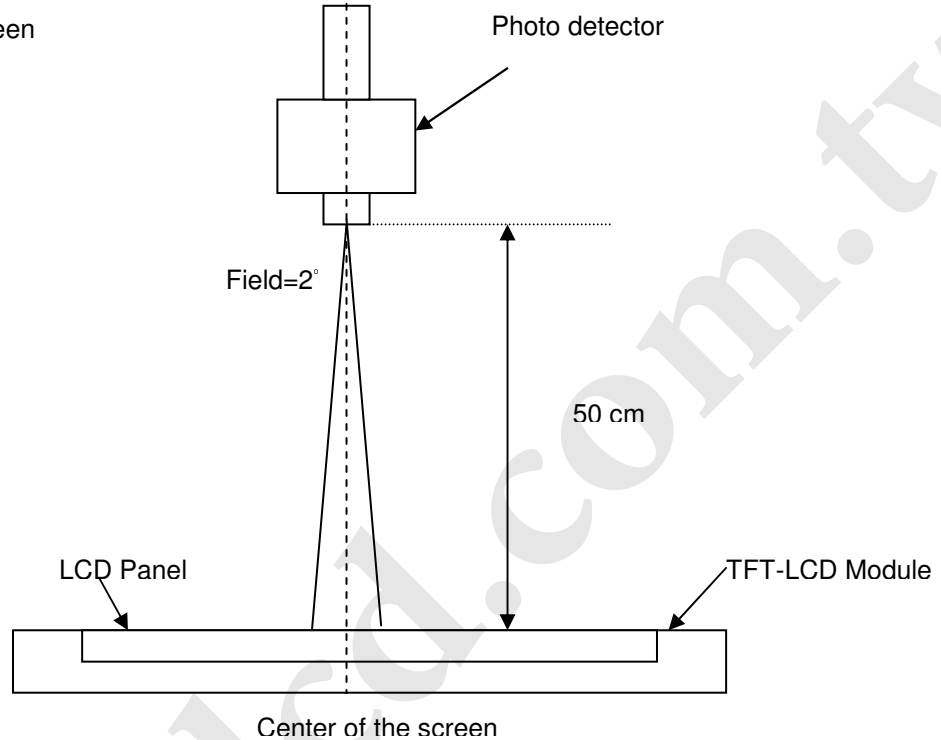

Note 5: Definition of Average Luminance of White (Y_L):

Measure the luminance of gray level 63 at 5 points , $Y_L = [L (1)+ L (2)+ L (3)+ L (4)+ L (5)] / 5$
 $L (x)$ is corresponding to the luminance of the point X at Figure in Note (1).

Note 6: Definition of contrast ratio:

Contrast ratio is calculated with the following formula.

$$\text{Contrast ratio (CR)} = \frac{\text{Brightness on the "White" state}}{\text{Brightness on the "Black" state}}$$

Note 7: Definition of Cross Talk (CT)

$$CT = |Y_B - Y_A| / Y_A \times 100 (\%)$$

Where

Y_A = Luminance of measured location without gray level 0 pattern (cd/m²)

Y_B = Luminance of measured location with gray level 0 pattern (cd/m²)

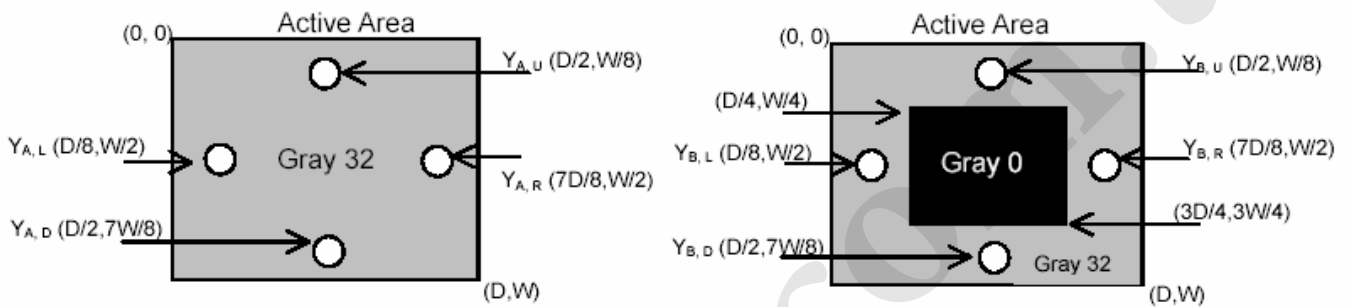

Note 8: Definition of response time:

The output signals of BM-7 or equivalent are measured when the input signals are changed from “Black” to “White” (falling time) and from “White” to “Black” (rising time), respectively. The response time interval between the 10% and 90% of amplitudes. Refer to figure as below.

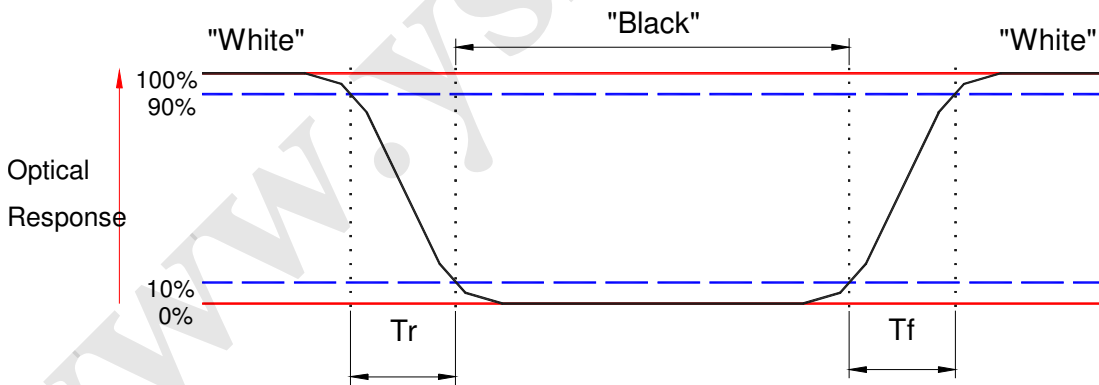

Note 9: Definition of viewing angle

Viewing angle is the measurement of contrast ratio ≥ 10 , at the screen center, over a 180° horizontal and 180° vertical range (off-normal viewing angles). The 180° viewing angle range is broken down as follows; 90° (θ) horizontal left and right and 90° (Φ) vertical, high (up) and low (down). The measurement direction is typically perpendicular to the display surface with the screen rotated about its center to develop the desired measurement viewing angle.

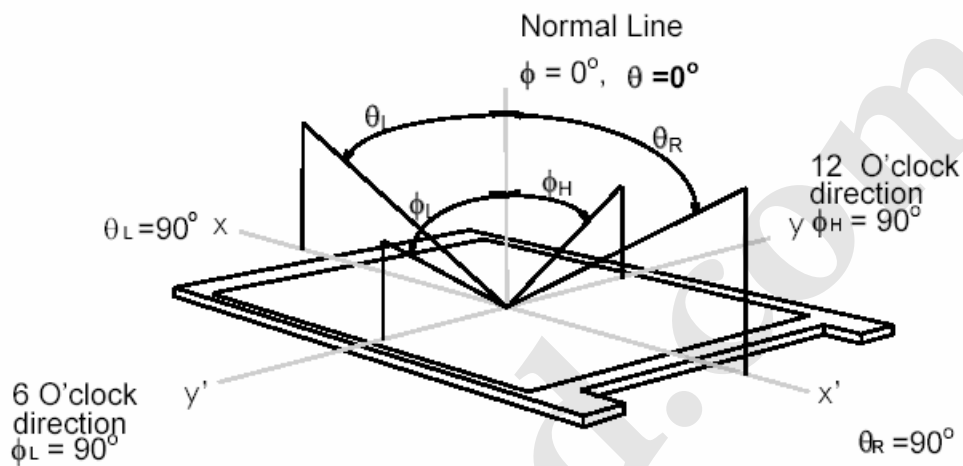

3. Functional Block Diagram

The following diagram shows the functional block of the 12.1 inches wide Color TFT/LCD Module:

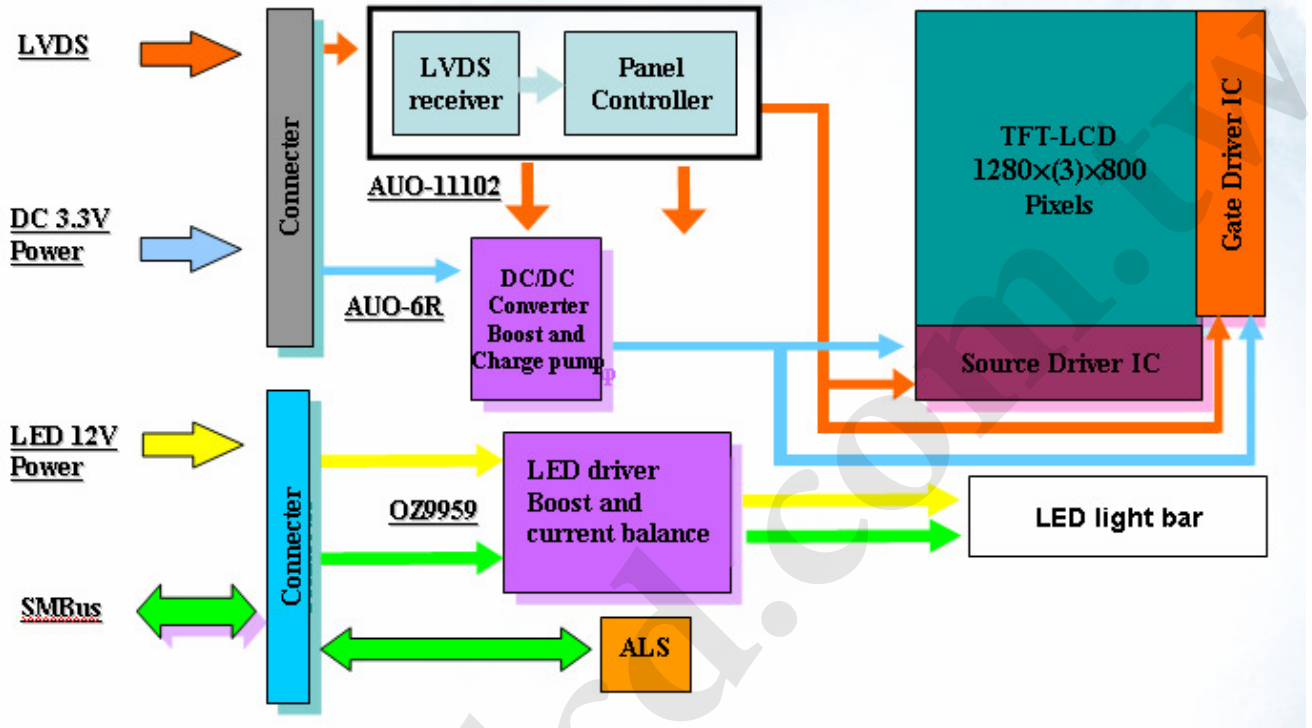

4. Absolute Maximum Ratings

Absolute maximum ratings of the module are as following:

4.1 Absolute Ratings of TFT LCD Module

Item	Symbol	Min	Max	Unit	Conditions
Logic/LCD Drive Voltage	VDD	-0.3	+4.0	[Volt]	Note 1,2

4.2 Absolute Ratings of Backlight Unit

Item	Symbol	Min	Max	Unit	Conditions
LED Current	ILED	-	20.0	[mA] rms	Note 1,2

4.3 Absolute Ratings of Environment

Item	Symbol	Min	Max	Unit	Conditions
Operating Temperature	TOP	0	+50	[°C]	Note 3
Operation Humidity	HOP	5	95	[%RH]	Note 3
Storage Temperature	TST	-20	+60	[°C]	Note 3
Storage Humidity	HST	5	95	[%RH]	Note 3

Note 1: At Ta (25°C)

Note 2: Permanent damage to the device may occur if exceed maximum values

Note 3: For quality performance, please refer to AUO IIS(Incoming Inspection Standard).

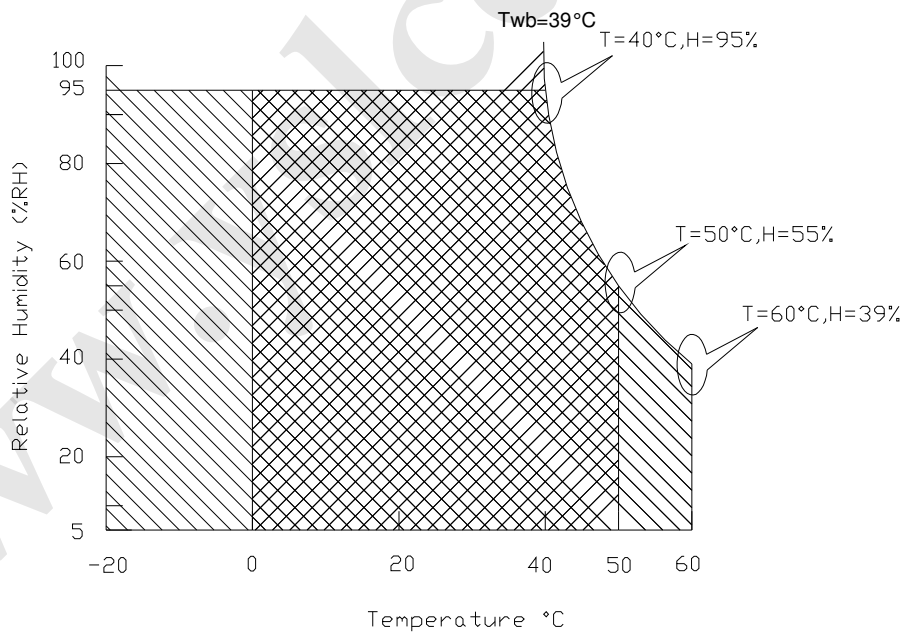

Operating Range



Storage Range

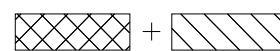

5. Electrical characteristics

5.1 TFT LCD Module

5.1.1 Power Specification

Input power specifications are as follows;

Symble	Parameter	Min	Typ	Max	Units	Note
VDD	Logic/LCD Drive Voltage	3.0	3.3	3.6	[Volt]	
PDD	VDD Power		1.3	1.5	[Watt]	Note 1
IDD	IDD Current		400	420	[mA]	Note 1
IRush	Inrush Current			1800	[mA]	Note 2
VDDrp	Allowable Logic/LCD Drive Ripple Voltage			500	[mV] p-p	
VDDns	Allowable Logic/LCD Drive Ripple Noise			100	[mV] p-p	

Note 1: Maximum Measurement Condition : Black Pattern

Note 2: Measure Condition

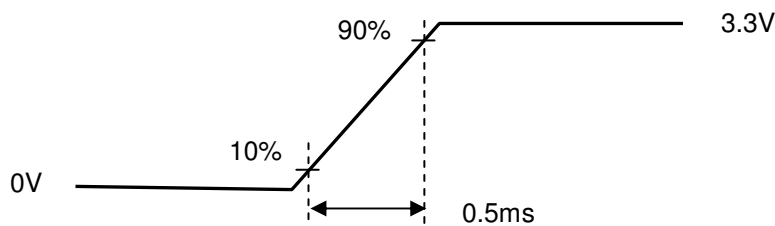
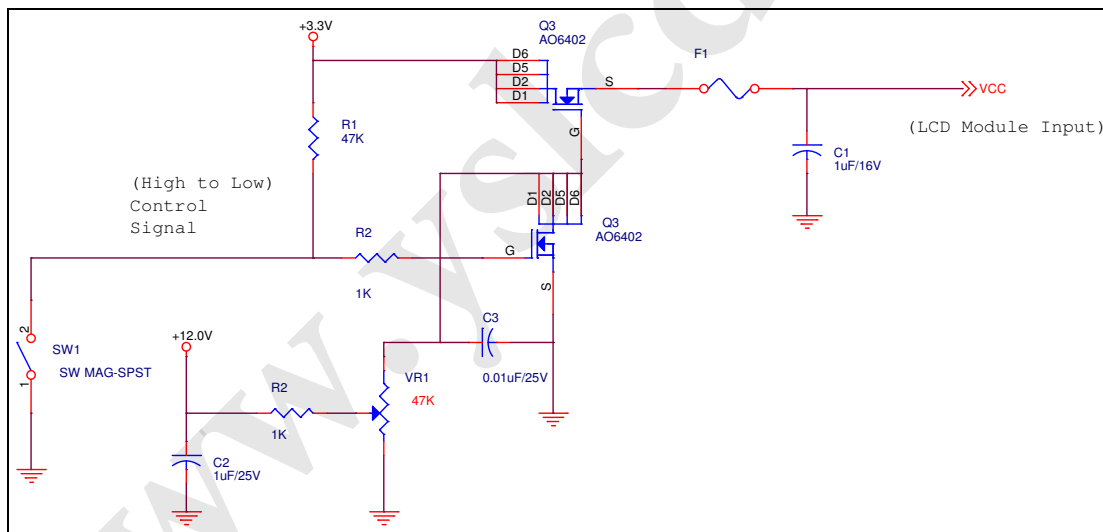

Vin rising time

5.1.2 Signal Electrical Characteristics

Input signals shall be low or High-impedance state when VDD is off.

Signal electrical characteristics are as follows;

Parameter	Condition	Min	Max	Unit
Vth	Differential Input High Threshold (Vcm=+1.2V)		100	[mV]
Vtl	Differential Input Low Threshold (Vcm=+1.2V)	-100		[mV]
Vcm	Differential Input Common Mode Voltage	0.3	2.2	[V]

Note: LVDS Differential Voltage

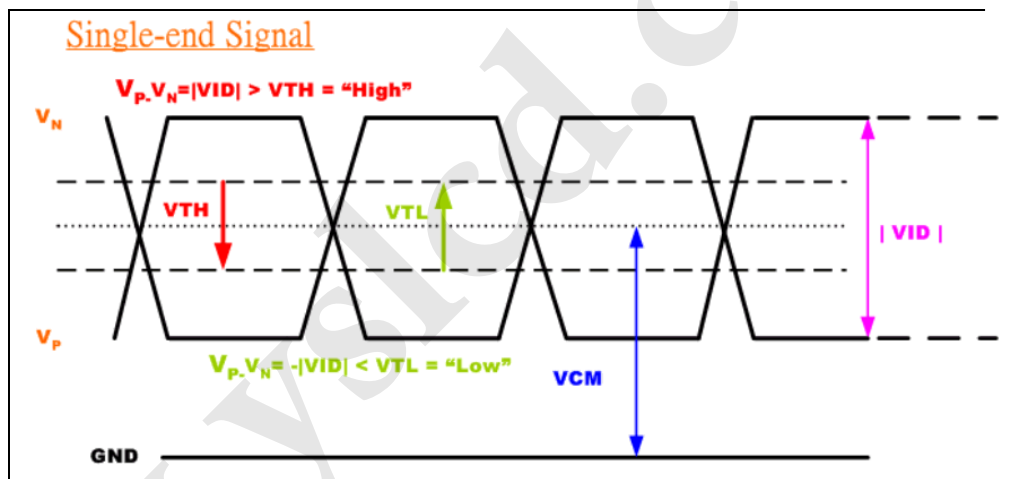

5.2 Backlight Unit

Parameter guideline for LED Inverter

Parameter	Min	Typ	Max	Units	Condition
White Luminance 5 points average	6100	6800	-	[cd/m ²]	(Ta=25°C)
LED current(I _{LED})	18.8	20.0	21.2	[mA] rms	(Ta=25°C)
LED Frequency(F _{LED})	-	800	-	[KHz]	(Ta=25°C)
LED Voltage (Reference) (V _{LED})	3.0	3.2	3.3	[Volt] rms	(Ta=25°C)
LED Power consumption (P _{LED}) @ 20.0 mA	-	3.6	4.0	[Watt]	(Ta=25°C) (Including circuit driving loss)

LED Parameter guideline for LED driving selection (Ref. Remark 1)

Parameter	Symbol	Min	Typ	Max	Units	Condition
LED Forward Voltage	V _F	3.00	3.20	3.40	[Volt]	(Ta=25°C)
LED Forward Current	I _F		20	35	[mA]	(Ta=25°C)
LED Power consumption	P _{LED}		3.61		[Watt]	(Ta=25°C) Note 1
LED Life-Time	N/A	10,000	-	-	Hour	(Ta=25°C) I _F =20 mA Note 2
Output PWM frequency	F _{PWM}	270	300	330	Hz	
Duty ratio	--	20	--	100	%	

Note 1: Calculator value for reference $I_F \times V_F = P$

Note 2: The LED life-time define as the estimated time to 50% degradation of initial lu

6. Signal Characteristic

6.1 Pixel Format Image

Following figure shows the relationship of the input signals and LCD pixel format.

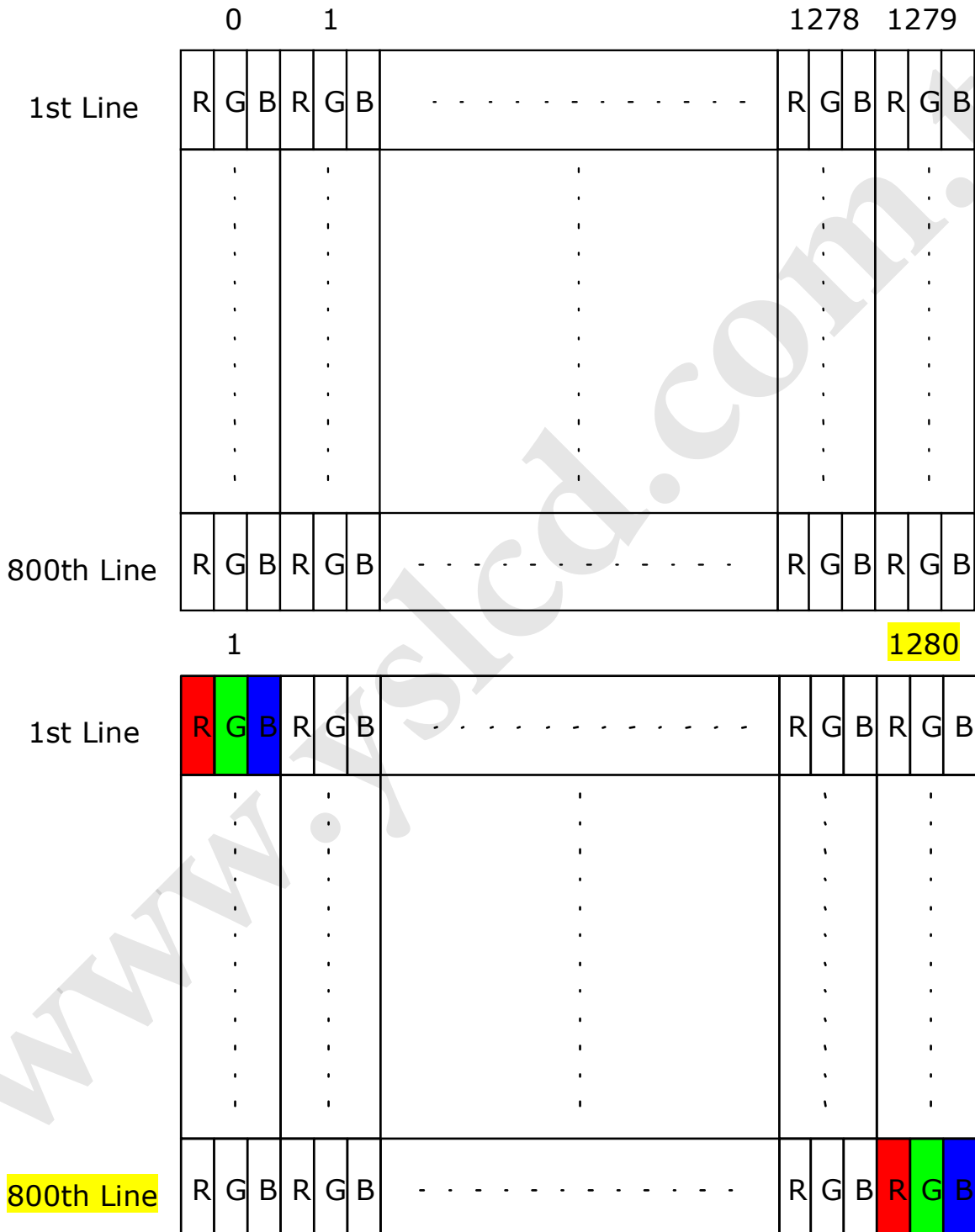

6.2 The input data format

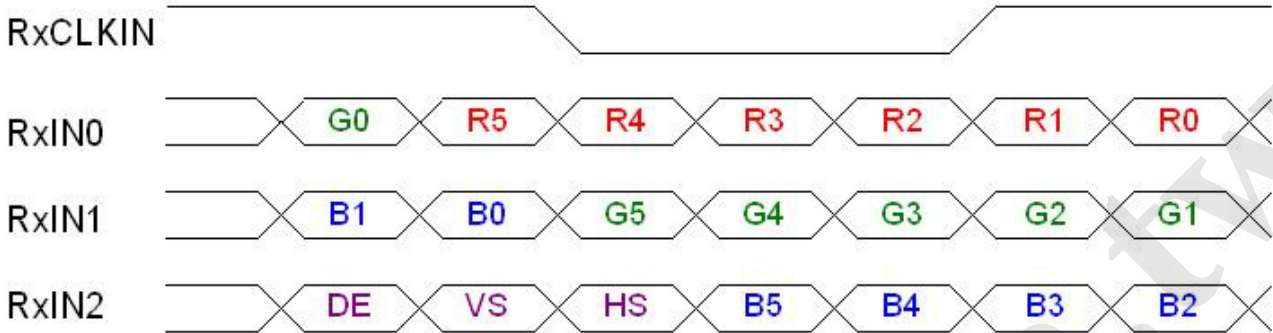

Signal Name	Description	
+RED5 (R5) +RED4 (R4) +RED3 (R3) +RED2 (R2) +RED1 (R1) +RED0 (R0)	Red Data 5 (MSB) Red Data 4 Red Data 3 Red Data 2 Red Data 1 Red Data 0 (LSB) (Red-pixel Data)	Red-pixel Data Each red pixel's brightness data consists of these 6 bits pixel data.
+GREEN 5 (G5) +GREEN 4 (G4) +GREEN 3 (G3) +GREEN 2 (G2) +GREEN 1 (G1) +GREEN 0 (G0)	Green Data 5 (MSB) Green Data 4 Green Data 3 Green Data 2 Green Data 1 Green Data 0 (LSB) (Green-pixel Data)	Green-pixel Data Each green pixel's brightness data consists of these 6 bits pixel data.
+BLUE 5 (B5) +BLUE 4 (B4) +BLUE 3 (B3) +BLUE 2 (B2) +BLUE 1 (B1) +BLUE 0 (B0)	Blue Data 5 (MSB) Blue Data 4 Blue Data 3 Blue Data 2 Blue Data 1 Blue Data 0 (LSB) (Blue-pixel Data)	Blue-pixel Data Each blue pixel's brightness data consists of these 6 bits pixel data.
-DTCLK	Data Clock	The typical frequency is 71.1 MHz. The signal is used to strobe the pixel data and DSPTMG signals. All pixel data shall be valid at the falling edge when the DSPTMG signal is high.
DSPTMG (DE)	Display Timing	This signal is stored at the falling edge of -DTCLK. When the signal is high, the pixel data shall be valid to be displayed.
VSYNC (VS)	Vertical Sync	The signal is synchronized to -DTCLK .
HSYNC (HS)	Horizontal Sync	The signal is synchronized to -DTCLK .

Note: Output signals from any system shall be low or High-impedance state when VDD is off.

6.3 Signal Description/Pin Assignment

LVDS (CN1) is a differential signal technology for LCD interface and high speed data transfer device.

Pin	Signal Name	Pin	Signal Name
1	KSO18	2	BAT2_LED
3	BAT2_LED	4	BREATH_PWRLED
5	KSI0	6	KSI1
7	DCP_SW	8	POWER_SD
9	GND	10	AUD_DMIC_CLK_G
11	AUC_DMIC_IN0	12	GND
13	LCD_ACLK+_MCH	14	LCD_ACLK-_MCH
15	GND	16	LCD_A2+_MCH
17	LCD_A2-_MCH	18	GND
19	LCD_A1+_MCH	20	LCD_A1-_MCH
21	GND	22	LCD_A0+_MCH
23	LCD_A0-_MCH	24	GND
25	LDDC_DATA_MCH	26	LDDC_CLK_MCH
27	LCD_TST	28	3V3_RUN
29	LCDVDD	30	LCDVDD

LED driving connector (CN2) provides the interface between system and LCD for control and power of LED BLU.

Pin	Signal Name	Pin	Signal Name
1	LCD_SMBCLK_LCD	2	LCD_SMBDAT_LCD
3	GND	4	BT_LED
5	LED_WLAN_OUT	6	HDD_LED
7	GND	8	KSI7
9	FP_RESET	10	3V3_ALW
11	3V3_RUN	12	3V3_Ntrig
13	3V3_Ntrig	14	KSI6
15	KSI5	16	KSI4
17	GND	18	USBP3_D-
19	USBP3_D+	20	GND
21	USBP5_D-	22	USBP5_D+
23	INVERTER_CBL_DET	24	GND
25	BIA_PWM_R	26	NC
27	GFX_PWR_SRC	28	GFX_PWR_SRC
29	GFX_PWR_SRC	30	GFX_PWR_SRC

Note1: Start from right side

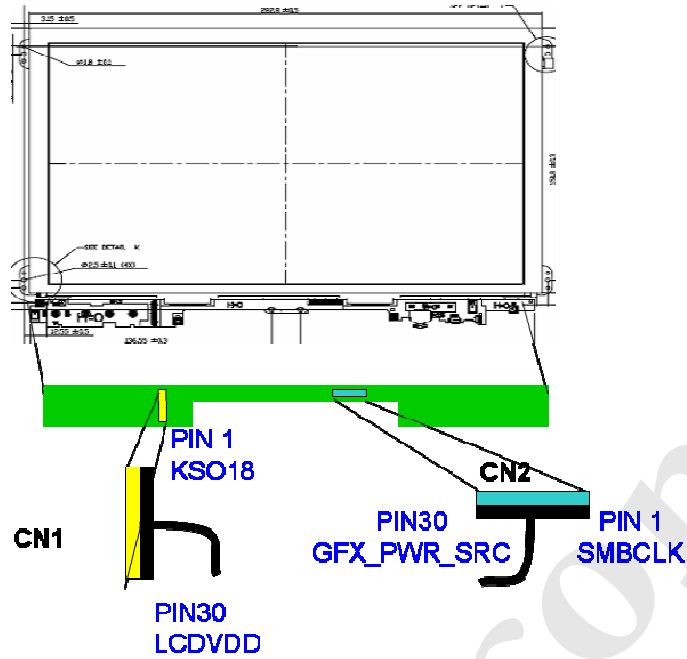

Note2: Input signals shall be low or High-impedance state when VDD is off.
Internal circuit of LVDS inputs are as following.

The module uses a 100ohm resistor between positive and negative data lines of each receiver input

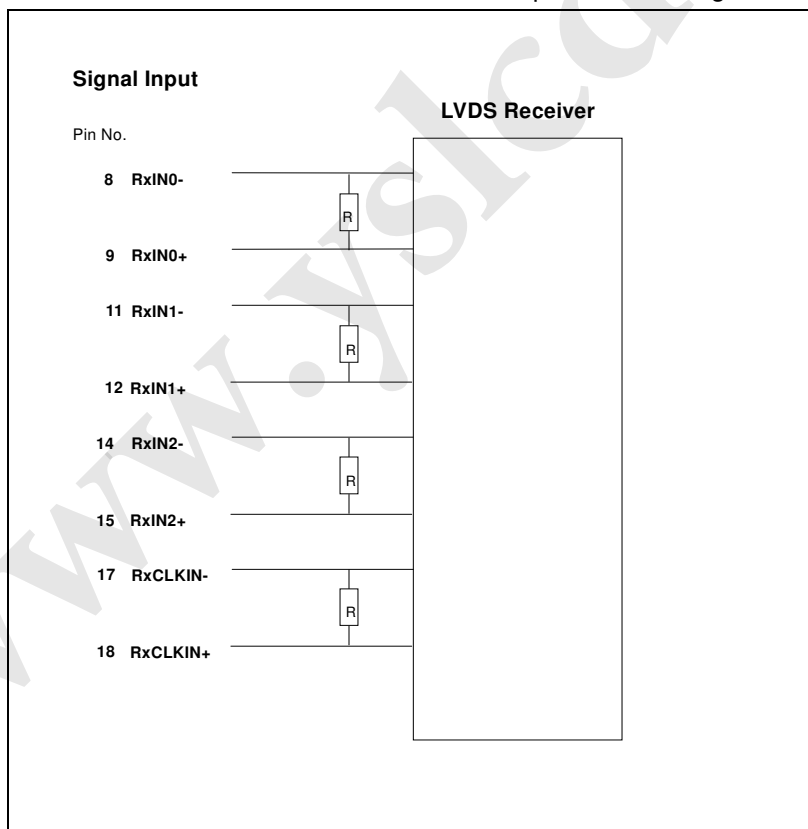

6.4 Interface Timing

6.4.1 Timing Characteristics

Basically, interface timings should match the 1280x800 /60Hz manufacturing guide line timing.

Parameter	Symbol	Min.	Typ.	Max.	Unit	
Frame Rate	-		60	-	Hz	
Clock frequency	$1/T_{Clock}$		71.1		MHz	
Vertical Section	Period	T_V	803	823	1023	T_{Line}
	Active	T_{VD}	800	800	800	
	Blanking	T_{VB}	3	23	223	
Horizontal Section	Period	T_H	1303	1440	2047	T_{Clock}
	Active	T_{HD}	1280	1280	1280	
	Blanking	T_{HB}	23	160	767	

Note: DE mode only

6.4.2 Timing diagram

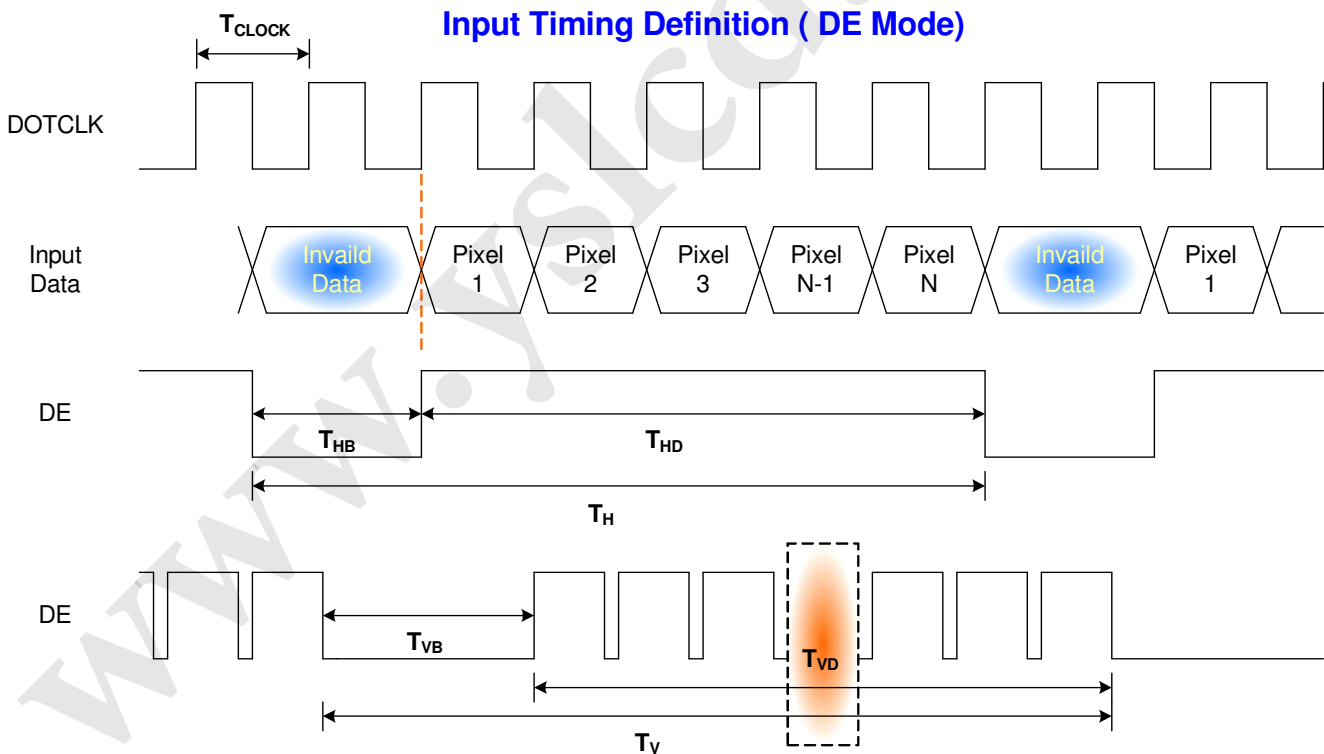

6.5 Power ON/OFF Sequence

VDD power and lamp on/off sequence is as follows. Interface signals are also shown in the chart. Signals from any system shall be Hi-Z state or low level when VDD is off.

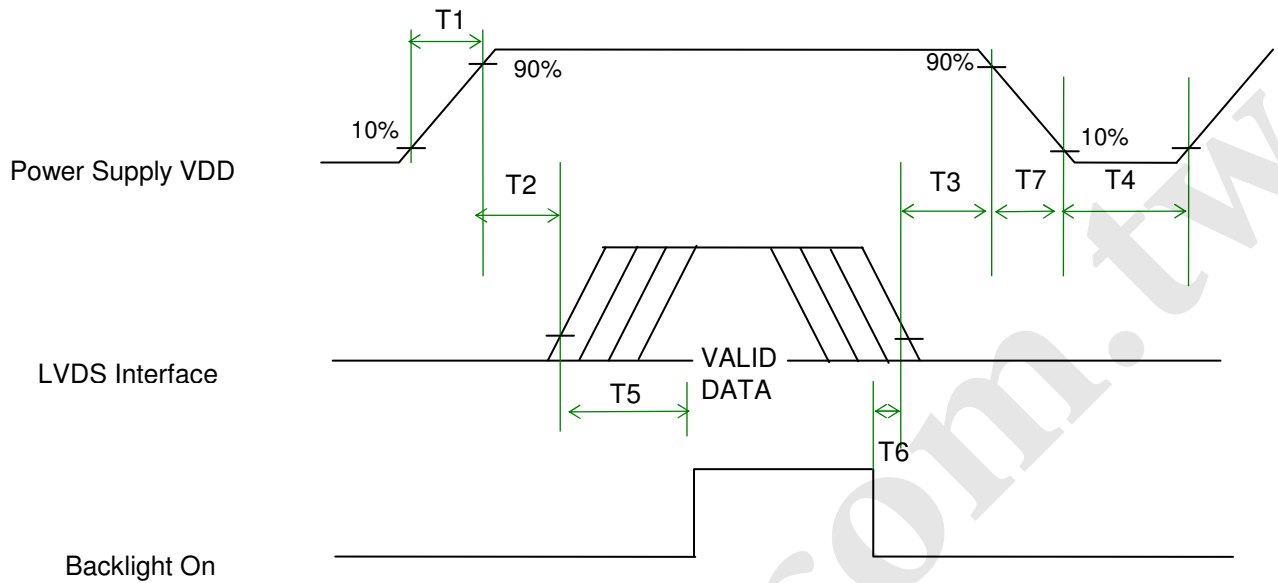

Power Sequence Timing

Parameter	Value			Units
	Min.	Typ.	Max.	
T1	0.5	-	10	(ms)
T2	0	-	50	(ms)
T3	0	-	50	(ms)
T4	400	-	-	(ms)
T5	200	-	-	(ms)
T6	200	-	-	(ms)
T7	0	-	10	(ms)

LED on/off sequence is as follows. Interface signals are also shown in the chart.

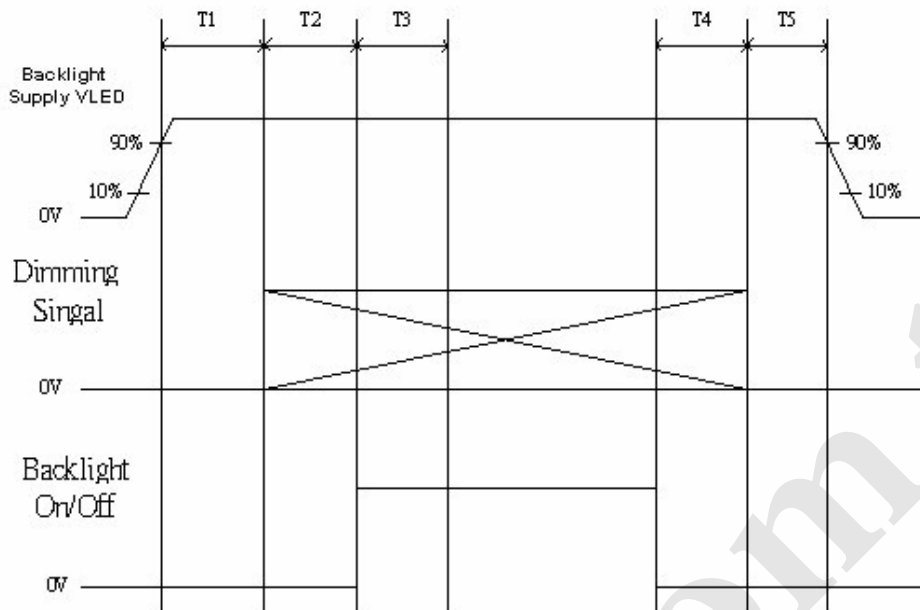

Symbol	Values			Unit
	Min	Typ	Max	
T1	10	---	---	ms
T2	10	---	---	
T3	50	---	---	
T4	0	---	---	
T5	10	---	---	

Note: The duty of LED dimming signal should be more than 20% in T2 and T3.

7. Connector Description

Physical interface is described as for the connector on module.

These connectors are capable of accommodating the following signals and will be following components.

Connector Name / Designation	LVDS (CN1)/ LED BLU (CN2)
Manufacturer	JAE
Type / Part Number	JAE FI-J30S-VF15N
Mating Housing/Part Number	JAE FI-J30C3
Mating Contact/Part Number	JAE FI-J30C3

CN401 connects PCB to LED stripe, respectively. The mating ends of these connectors are FPC.

Connector Name / Designation	PCBA to LED stripe (CN401)
Manufacturer	SIN SHENG TERMINAL & MACHINE INC.
Type / Part Number	MS24022P10

8. Vibration and Shock Test

8.1 Vibration Test

Test Spec:

- Test method: Non-Operation
- Acceleration: 1.5G , sine wave
- Frequency: 10 - 500Hz Random
- Sweep: 0.5 octave/minute in each of three mutually perpendicular axes.

8.2 Shock Test Spec:

Test Spec:

- Test method: Non-Operation
- Acceleration: 180 G , Half sine wave
- Active time: 2 ms
- Pulse: Half sine wave

9. Reliability

Subject	Description
Operating High Temperature	+50°C ,Dynamic ,250hr ,Humidity 20%
Operating Low Temperature	0°C ,Dynamic ,250hr ,Humidity 20%
Storage High Temperature	+65°C ,Non_Operating ,250hr ,Humidity 20%
Storage Low Temperature	-20°C ,Non_Operating ,250hr
High Temp &High Humidity	+40°C ,Dynamic ,Humidity 95% ,250hr
Temperature Cycling Non-Operating	-40°C to +65°C ,Ramp< 20°C /min, Duration at Temp. = 30 min, Test Cycles =50
Altitude	Op(0~14000 ft) Non-op (0~40000ft)
MTBF	200K hrs
Storage Shock	180g's, 2.0 ms, Half Sine Wave ± 3 Axis (+X, -X, +Y, -Y, +Z, -Z) 1Shocks per Direction
Storage Vibration	1.5 Grms, 30 min/side, PSD Spectrum Break Points, 26 Hz G2/Hz=0.316, 50 Hz G2/Hz=0.007, 222 Hz G2/Hz=0.0018, 500Hz G2/Hz=0.0001
ESD	Contact : ±8 KV Air : ±15 KV

Note1: According to EN61000-4-2, ESD class B: Some performance degradation allowed. No data lost. Self-recoverable. No hardware failures.

Note2: MTBF (Excluding the LED): 20,000 hours with a confidence level 90%.

10. Mechanical Characteristics

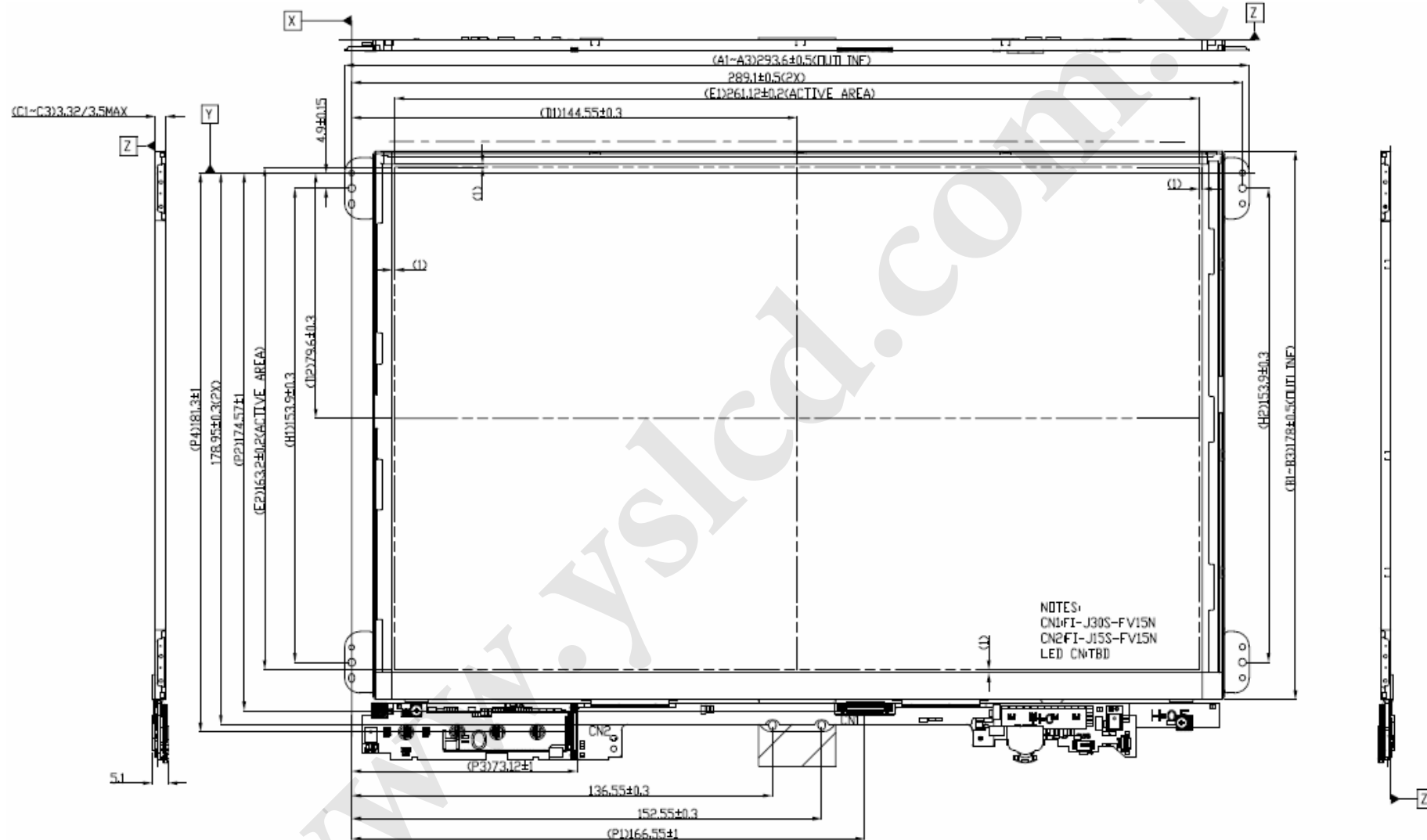



Product Specification

B121EW10 V0

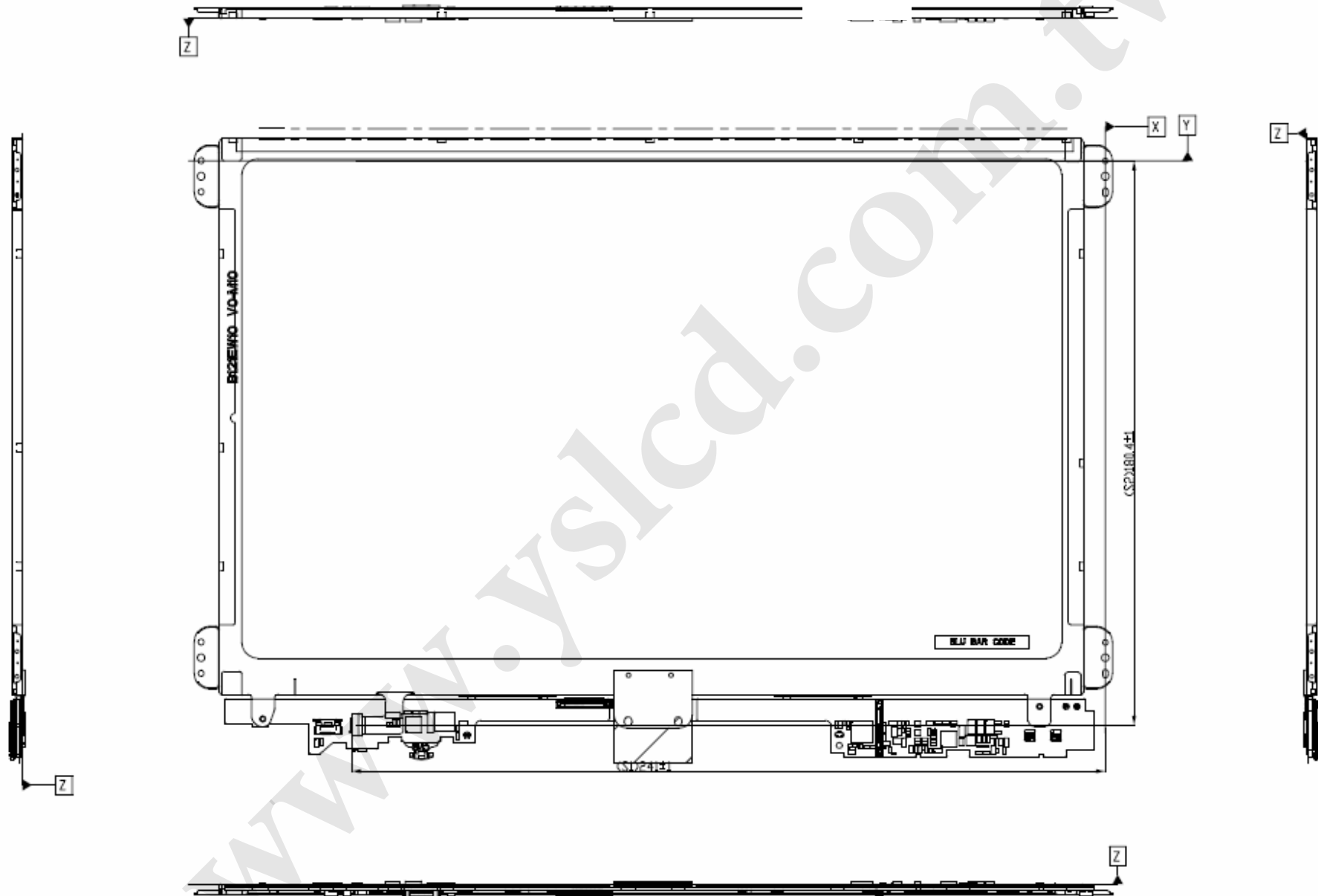

11. Shipping and Package

11.1 Shipping Label Format

AUO LCD S/N Label: This label records the model name, firmware/ hardware version, manufacture date, and serial number of the LCD in AUO.

•AUO PN: 97.12B10.000



•AUO PN: 97.12B10.001

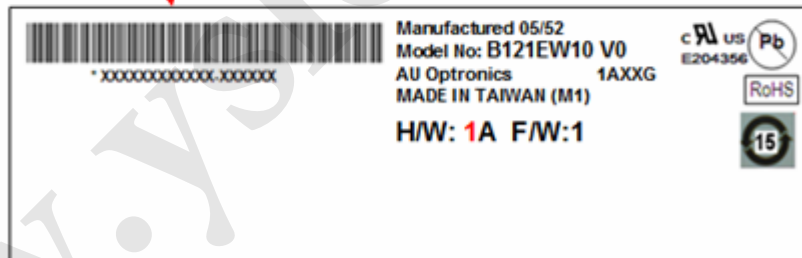



Product Specification

B121EW10 V0

Carton label: This label is pasted on the carton to identify the quantity in each carton, Dell part number, and manufacture date.

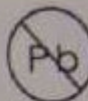
AU Optronics QTY : 20 RoHS 

MODEL NO : B121EW10 V0

PART NO : 97.12B10.000

CUSTOMER NO :

CARTON NO : 

MADE IN TAIWAN *****ZS0307 - 0822500037*

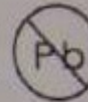
AU Optronics QTY : 20 RoHS 

MODEL NO : B121EW10 V0

PART NO : 97.12B10.001

CUSTOMER NO :

CARTON NO : 

MADE IN TAIWAN *****ZS0307 - 0822500037*

11.2. Carton package

The outside dimension of carton is 423(L)mm* 374(W)mm* 335(H)mm, carton and cushion weight are 1800g.

Maximum quantity of each carton is 20 pcs LCD.

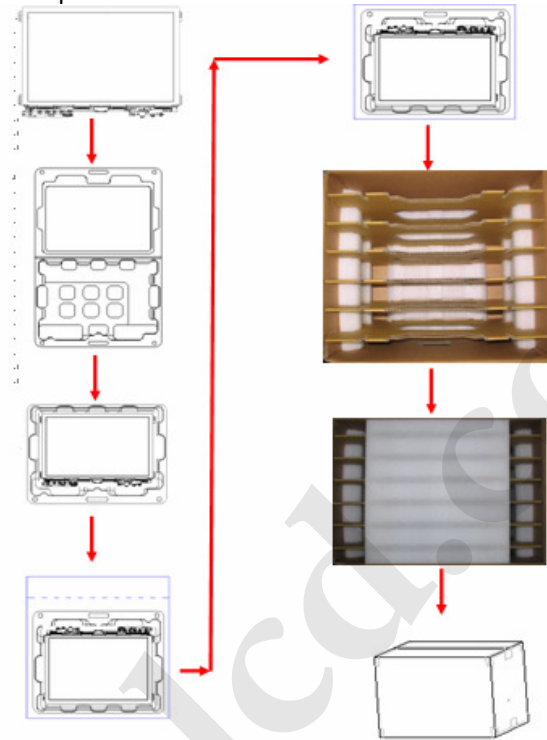

11.3 Shipping package of palletizing

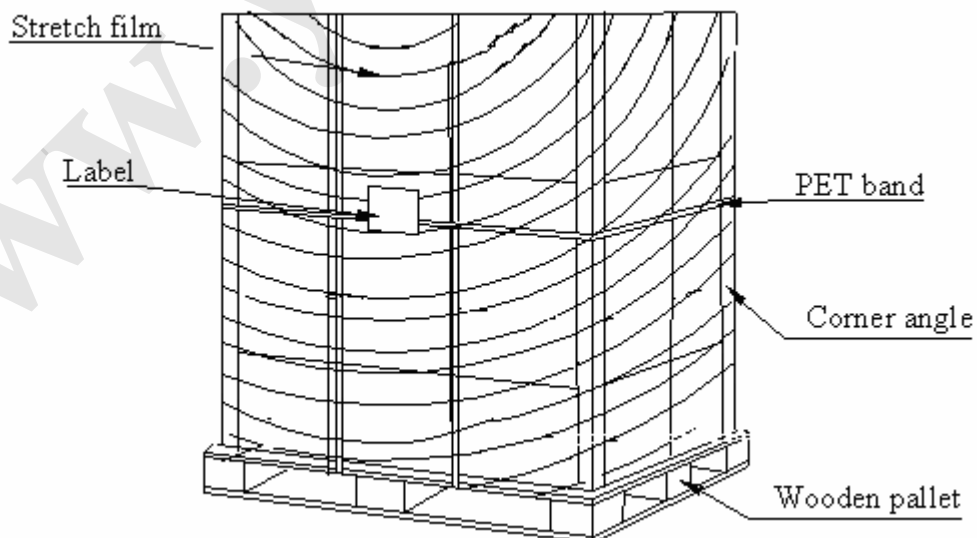



12. Appendix: EDID description

Byte (hex)	Field Name and Comments	Value (hex)	Value (binary)	Value (DEC)
0	Header	00	00000000	0
1	Header	FF	11111111	255
2	Header	FF	11111111	255
3	Header	FF	11111111	255
4	Header	FF	11111111	255
5	Header	FF	11111111	255
6	Header	FF	11111111	255
7	Header	00	00000000	0
8	EISA manufacture code = 3 Character ID	06	00000110	6
9	EISA manufacture code (Compressed ASCII)	AF	10101111	175
0A	Panel Supplier Reserved – Product Code	14	00010100	20
0B	Panel Supplier Reserved – Product Code	A1	10100001	161
0C	LCD module Serial No - Preferred but Optional (“0” if not used)	00	00000000	0
0D	LCD module Serial No - Preferred but Optional (“0” if not used)	00	00000000	0
0E	LCD module Serial No - Preferred but Optional (“0” if not used)	00	00000000	0
0F	LCD module Serial No - Preferred but Optional (“0” if not used)	00	00000000	0
10	Week of manufacture	01	00000001	1
11	Year of manufacture	12	00010010	18
12	EDID structure version # = 1	01	00000001	1
13	EDID revision # = 3	03	00000011	3
14	Video I/P definition = Digital I/P (80h)	90	10010000	144
15	Max H image size = cm(Rounded to cm)	1A	00011010	26
16	Max V image size = ?? cm(Rounded to cm)	10	00010000	16
17	Display gamma = (gamma ×100)-100 = Example: (2.2×100) – 100 = 120	78	01111000	120
18	Feature support (no DPMS, Active off, RGB, timing BLK 1)	0A	00001010	10
19	Red/Green Low bit (RxRy/GxGy)	50	01010000	80
1A	Blue/White Low bit (BxBY/WxWy)	C5	11000101	197
1B	Red X Rx =	98	10011000	152
1C	Red Y Ry =	58	01011000	88
1D	Green X Rx =	52	01010010	82
1E	Green Y Ry =	8E	10001110	142



Product Specification

B121EW10 V0

1F	Blue X	Rx =	27	00100111	39
20	Blue Y	Ry =	25	00100101	37
21	White X	Rx =	50	01010000	80
22	White Y	Ry =	54	01010100	84
23	Established timings 1 (00h if not used)		00	00000000	0
24	Established timings 2 (00h if not used)		00	00000000	0
25	Manufacturer's timings (00h if not used)		00	00000000	0
26	Standard timing ID1 (01h if not used)		01	00000001	1
27	Standard timing ID1 (01h if not used)		01	00000001	1
28	Standard timing ID2 (01h if not used)		01	00000001	1
29	Standard timing ID2 (01h if not used)		01	00000001	1
2A	Standard timing ID3 (01h if not used)		01	00000001	1
2B	Standard timing ID3 (01h if not used)		01	00000001	1
2C	Standard timing ID4 (01h if not used)		01	00000001	1
2D	Standard timing ID4 (01h if not used)		01	00000001	1
2E	Standard timing ID5 (01h if not used)		01	00000001	1
2F	Standard timing ID5 (01h if not used)		01	00000001	1
30	Standard timing ID6 (01h if not used)		01	00000001	1
31	Standard timing ID6 (01h if not used)		01	00000001	1
32	Standard timing ID7 (01h if not used)		01	00000001	1
33	Standard timing ID7 (01h if not used)		01	00000001	1
34	Standard timing ID8 (01h if not used)		01	00000001	1
35	Standard timing ID8 (01h if not used)		01	00000001	1
36	Pixel Clock/10,000 (LSB)		EA	11101010	234
37	Pixel Clock/10,000 (MSB)		1A	00011010	26
38	Horizontal Active = pixels (lower 8 bits)		00	00000000	0
39	Horizontal Blanking (Thbp) = 320 pixels (lower 8 bits)		7E	01111110	126
3A	Horizontal Active/Horizontal blanking (Thbp) (upper4:4 bits)		50	01010000	80
3B	Vertical Active = lines		20	00100000	32
3C	Vertical Blanking (Tvbp) = lines (DE Blanking typ. for DE only panels)		10	00010000	16
3D	Vertical Active : Vertical Blanking (Tvbp) (upper4:4 bits)		30	00110000	48
3E	Horizontal Sync, Offset (Thfp) = pixels		30	00110000	48
3F	Horizontal Sync, Pulse Width = pixels		20	00100000	32



Product Specification

B121EW10 V0

40	Vertical Sync, Offset (Tvfp) =lines Sync Width = lines	36	00110110	54
41	Horizontal Vertical Sync Offset/Width upper 2 bits	00	00000000	0
42	Horizontal Image Size =mm	05	00000101	5
43	Vertical image Size = mm	A3	10100011	163
44	Horizontal Image Size / Vertical image size	10	00010000	16
45	Horizontal Border = 0 (Zero for Notebook LCD)	00	00000000	0
46	Vertical Border = 0 (Zero for Notebook LCD)	00	00000000	0
47	if display uses standard blanking (HSyncPolarity = POS, VSyncPolarity = NEG) , for DVD compliance.	1A	00011010	26
48	Pixel Clock/10,000 (LSB)	EA	11101010	234
49	Pixel Clock/10,000 (MSB)	1A	00011010	26
4A	Horizontal Active = xxxx pixels (lower 8 bits)	00	00000000	0
4B	Horizontal Blanking (Thbp) = xxxx pixels (lower 8 bits)	7E	01111110	126
4C	Horizontal Active/Horizontal blanking (Thbp) (upper4:4 bits)	50	01010000	80
4D	Vertical Active = xxxx lines	20	00100000	32
4E	Vertical Blanking (Tvbp) = xxxx lines (DE Blanking typ. for DE only panels)	10	00010000	16
4F	Vertical Active : Vertical Blanking (Tvbp) (upper4:4 bits)	30	00110000	48
50	Horizontal Sync, Offset (Thfp) = xxxx pixels	30	00110000	48
51	Horizontal Sync, Pulse Width = xxxx pixels	20	00100000	32
52	Vertical Sync, Offset (Tvfp) = xx lines Sync Width = xx lines	36	00110110	54
53	Horizontal Vertical Sync Offset/Width upper 2 bits	00	00000000	0
54	Horizontal Image Size =xxx mm	05	00000101	5
55	Vertical image Size = xxx mm	A3	10100011	163
56	Horizontal Image Size / Vertical image size	10	00010000	16
57	Horizontal Border = 0 (Zero for Notebook LCD)	00	00000000	0
58	Vertical Border = 0 (Zero for Notebook LCD)	00	00000000	0
59	if display uses standard blanking (HSyncPolarity = POS, VSyncPolarity = NEG) , for DVD compliance.	1A	00011010	26
5A	Flag	00	00000000	0
5B	Flag	00	00000000	0
5C	Flag	00	00000000	0
5D	Dummy Descriptor	FE	11111110	254



Product Specification

B121EW10 V0

5E	Flag	00	00000000	0
5F	Dell P/N 1 st Character	59	01011001	89
60	Dell P/N 2 nd Character	37	00110111	55
61	Dell P/N 3 rd Character	34	00110100	52
62	Dell P/N 4 th Character	37	00110111	55
63	Dell P/N 5 th Character	44	01000100	68
64	EEDID Revision =	80	10000000	128
65	Manufacturer P/N	42	01000010	66
66	Manufacturer P/N	31	00110001	49
67	Manufacturer P/N	32	00110010	50
68	Manufacturer P/N	31	00110001	49
69	Manufacturer P/N	45	01000101	69
6A	Manufacturer P/N	57	01010111	87
6B	Manufacturer P/N (If <13 char, then terminate with ASCII code 0Ah, set remaining char = 20h)	30	00110000	48
6C	Flag	00	00000000	0
6D	Flag	00	00000000	0
6E	Flag	00	00000000	0
6F	Data Type Tag:	00	00000000	0
70	Flag	00	00000000	0
71	SMBUS Value = 00nits	00	00000000	0
72	SMBUS Value = 00nits	00	00000000	0
73	SMBUS Value = 00nits	00	00000000	0
74	SMBUS Value = 00 nits	00	00000000	0
75	SMBUS Value = 00nits	00	00000000	0
76	SMBUS Value = 00 nits	00	00000000	0
77	SMBUS Value = 00 nits	00	00000000	0
78	SMBUS Value = 00nits	00	00000000	0
79	Bit[1:0] 00: reserved, 01: single LVDS, 10: dual LVDS, 11: reserved Bit[2] 0: No RTC support, 1: RTC support Bit[7:3] Reserved	01	00000001	1
7A	Bit[0] 0: No BIST support, 1: BIST support Bit[7:1] Reserved	01	00000001	1
7B	(If <13 char, then terminate with ASCII code 0Ah, set remaining char = 20h)	0A	00001010	10



Product Specification

B121EW10 V0

7C	(If <13 char, then terminate with ASCII code 0Ah, set remaining char = 20h)	20	00100000	32
7D	(If <13 char, then terminate with ASCII code 0Ah, set remaining char = 20h)	20	00100000	32
7E	Extension flag (# of optional 128 EDID extension blocks to follow, Typ = 0)	00	00000000	0
7F	Checksum (The 1-byte sum of all 128 bytes in this EDID block shall = 0)	A5	10100101	165