



# Product Specification

B121EW10 V1

(  ) Preliminary Specifications

(  ) Final Specifications

<b>Module</b>	12.1" WXGA Color TFT-LCD with Digitizer
<b>Model Name</b>	B121EW10 V1 (Dell P/N: Y747D)

Customer	Date
_____	_____
<b>Checked &amp; Approved by</b>	
_____	_____
Note: This Specification is subject to change without notice.	

Approved by	Date
Howard Lee	2008/05/16
<b>Prepared by</b>	
Kay CY Wang	2008/05/15
NBBU Marketing Division / AU Optronics corporation	



## Contents

<b>1. Handling Precautions</b> .....	<b>4</b>
<b>2. General Description</b> .....	<b>5</b>
2.1 General Specification.....	5
2.2 Optical Characteristics .....	6
<b>3. Functional Block Diagram</b> .....	<b>11</b>
<b>4. Absolute Maximum Ratings</b> .....	<b>12</b>
4.1 Absolute Ratings of TFT LCD Module .....	12
4.2 Absolute Ratings of Backlight Unit.....	12
4.3 Absolute Ratings of Environment.....	12
<b>5. Electrical characteristics</b> .....	<b>13</b>
5.1 TFT LCD Module .....	13
5.2 Backlight Unit.....	15
<b>6. Signal Characteristic</b> .....	<b>16</b>
6.1 Pixel Format Image.....	16
6.2 The input data format.....	17
6.3 Signal Description/Pin Assignment .....	18
6.4 Interface Timing .....	21
6.5 Power ON/OFF Sequence.....	22
<b>7. Digitizer Specification</b> .....	<b>23</b>
<b>8. Connector Description</b> .....	<b>25</b>
<b>9. Vibration and Shock Test</b> .....	<b>26</b>
9.1 Vibration Test .....	26
9.2 Shock Test Spec: .....	26
<b>10. Reliability</b> .....	<b>27</b>
<b>11. Mechanical Characteristics</b> .....	<b>28</b>
<b>12. Shipping and Package</b> .....	<b>30</b>
12.1 Shipping Label Format.....	30
12.2. Carton package .....	31
12.3 Shipping package of palletizing .....	31
<b>13. Appendix: EDID description</b> .....	<b>32</b>



# Product Specification

---

B121EW10 V1

## Record of Revision

Version and Date	Page	Old description	New Description	Remark
0.1 2008/05/15	All	First Edition for Customer		

### 1. Handling Precautions

- 1) Since front polarizer is easily damaged, pay attention not to scratch it.
- 2) Be sure to turn off power supply when inserting or disconnecting from input connector.
- 3) Wipe off water drop immediately. Long contact with water may cause discoloration or spots.
- 4) When the panel surface is soiled, wipe it with absorbent cotton or other soft cloth.
- 5) Since the panel is made of glass, it may break or crack if dropped or bumped on hard surface.
- 6) Since CMOS LSI is used in this module, take care of static electricity and insure human earth when handling.
- 7) Do not open nor modify the Module Assembly.
- 8) Do not press the reflector sheet at the back of the module to any directions.
- 9) In case if a Module has to be put back into the packing container slot after once it was taken out from the container, do not press the center of the LED Reflector edge. Instead, press at the far ends of the CFL Reflector edge softly. Otherwise the TFT Module may be damaged.
- 10) At the insertion or removal of the Signal Interface Connector, be sure not to rotate nor tilt the Interface Connector of the TFT Module.
- 11) After installation of the TFT Module into an enclosure (Notebook PC Bezel, for example), do not twist nor bend the TFT Module even momentary. At designing the enclosure, it should be taken into consideration that no bending/twisting forces are applied to the TFT Module from outside. Otherwise the TFT Module may be damaged.
- 12) Small amount of materials having no flammability grade is used in the LCD module. The LCD module should be supplied by power complied with requirements of Limited Power Source (IEC60950 or UL1950), or be applied exemption.
- 13) Disconnecting power supply before handling LCD modules, it can prevent electric shock, DO NOT TOUCH the electrode parts, cables, connectors and LED circuit part of TFT module that a LED light bar build in as a light source of back light unit. It can prevent electrostatic breakdown.

## 2. General Description

B121EW10 V1 is a Color Active Matrix Liquid Crystal Display composed of a TFT LCD panel, a driver circuit, LED backlight system, and a digitizer unit. The screen format is intended to support the WXGA (1280(H) x 800(V)) screen and 262k colors (RGB 6-bits data driver) with LED backlight driving circuit. All input signals are LVDS interface compatible.

B121EW10 V1 is designed for a display unit of tablet style personal computer and industrial machine.

### 2.1 General Specification

The following items are characteristics summary on the table at 25 °C condition:

Items	Unit	Specifications			
Screen Diagonal	[mm]	307.9 (12.1 W")			
Active Area	[mm]	261.12 (H) x 163.2 (V)			
Pixels H x V		1280x3(RGB) x 800			
Pixel Pitch	[mm]	0.204			
Pixel Arrangement		R.G.B. Vertical Stripe			
Display Mode		Normally White			
White Luminance (ILED=20.0mA) Note: ILED is lamp current	[cd/m <sup>2</sup> ]	450 Typ. (5 points average) 380 Min. (5 points average) (Note1)			
Luminance Uniformity		1.25 max. (5 points)			
Contrast Ratio		600:1 Typ.,500:1 Min.			
Optical Rise Time/Fall Time	[msec]	16 Typ., 25 Max.			
Nominal Input Voltage VDD	[Volt]	+3.3 Typ.			
Power Consumption	[Watt]	5.5 Max. (Including logic and BLU power,with LED circuit loss) @ 20.0 mA			
Weight (w/o Inverter)	[Grams]	450g Max.			
Physical Size	[mm]		L	W	T
		Max	294.1	180.4	6.05
		Typ	293.6	180.1	-
		min	293.1	179.8	-
Electrical Interface		1 channel LVDS			
Surface Treatment		Anti-galre, 3H			
Support Color		262K colors ( RGB 6-bit )			
Temperature Range Operating Storage (Non-Operating)	[°C] [°C]	0 to +50 -20 to +60			
RoHS Compliance		RoHS Compliance			

### 2.2 Optical Characteristics

The optical characteristics are measured under stable conditions at 25°C (Room Temperature):

Item	Unit	Conditions	Min.	Typ.	Max.	Note
White Luminance ILED=20.0mA	[cd/m <sup>2</sup> ]	5 points average	380	450	-	1, 4, 5.
Viewing Angle	[degree] [degree]	Horizontal (Right) CR = 10 (Left)	70	80	-	8
			70	80	-	
	Vertical (Upper) CR = 10 (Lower)	70	80	-		
		70	80	-		
Luminance Uniformity		5 Points			1.25	1
Luminance Uniformity		13 Points			1.80	2
CR: Contrast Ratio			500	600	-	6
Cross talk	%				1.4	7
Response Time	[msec]	Rising	-	15	20	8
	[msec]	Falling	-	10	15	
	[msec]	Rising + Falling		25	35	
Color / Chromaticity Coordinates  (CIE 1931)		<b>Red x</b>	0.565	0.595	0.625	2,8
		<b>Red y</b>	0.315	0.345	0.375	
		<b>Green x</b>	0.290	0.320	0.350	
		<b>Green y</b>	0.525	0.555	0.585	
		<b>Blue x</b>	0.125	0.155	0.185	
		<b>Blue y</b>	0.115	0.145	0.175	
		<b>White x</b>	0.283	0.313	0.343	
		<b>White y</b>	0.299	0.329	0.359	
NTSC	[%]	CIE 1931	-	45	-	

**Note 1:** 5 points position (Display area: 261.12 (H) x 163.2 (V) mm)

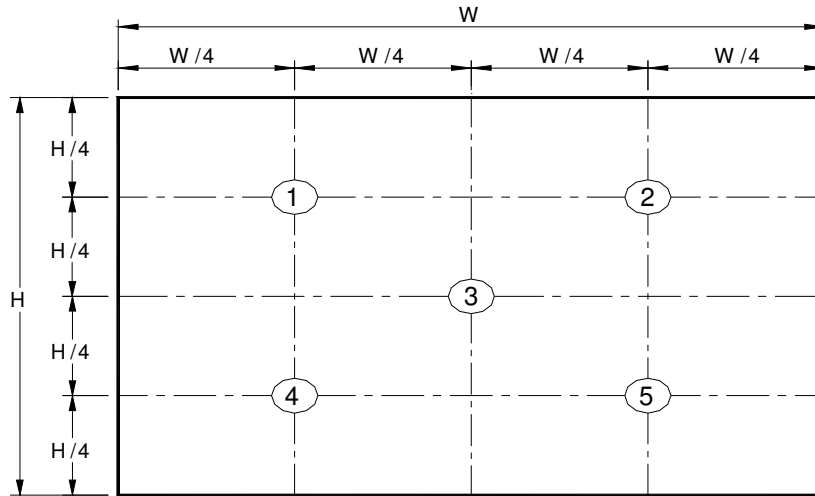

**Note 2:** 13 points position

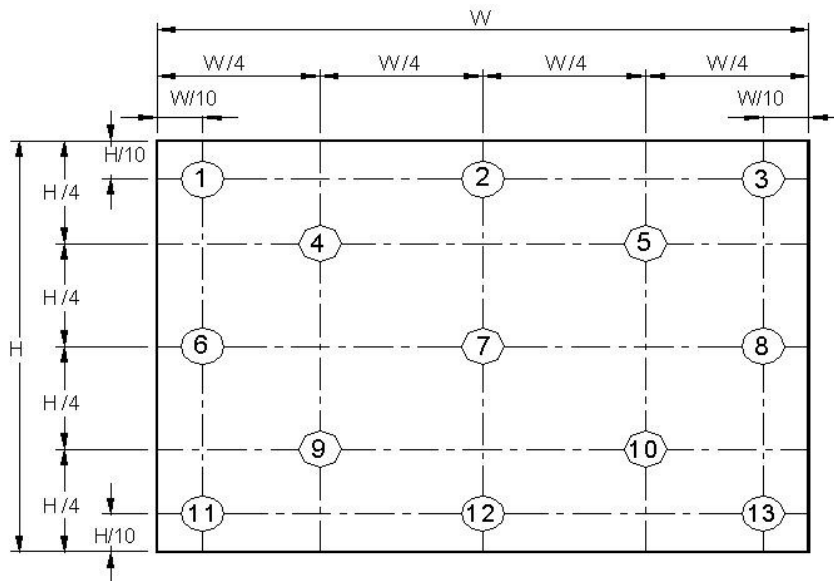

**Note 3:** The luminance uniformity of 5 and 13 points is defined by dividing the maximum luminance values by the minimum test point luminance

$$\delta_{w5} = \frac{\text{Maximum Brightness of five points}}{\text{Minimum Brightness of five points}}$$

$$\delta_{w13} = \frac{\text{Maximum Brightness of thirteen points}}{\text{Minimum Brightness of thirteen points}}$$

**Note 4:** Measurement method

The LCD module should be stabilized at given temperature for 30 minutes to avoid abrupt temperature change during measuring. In order to stabilize the luminance, the measurement should be executed after lighting Backlight for 30 minutes in a stable, windless and dark room, and it should be measured in the center of screen

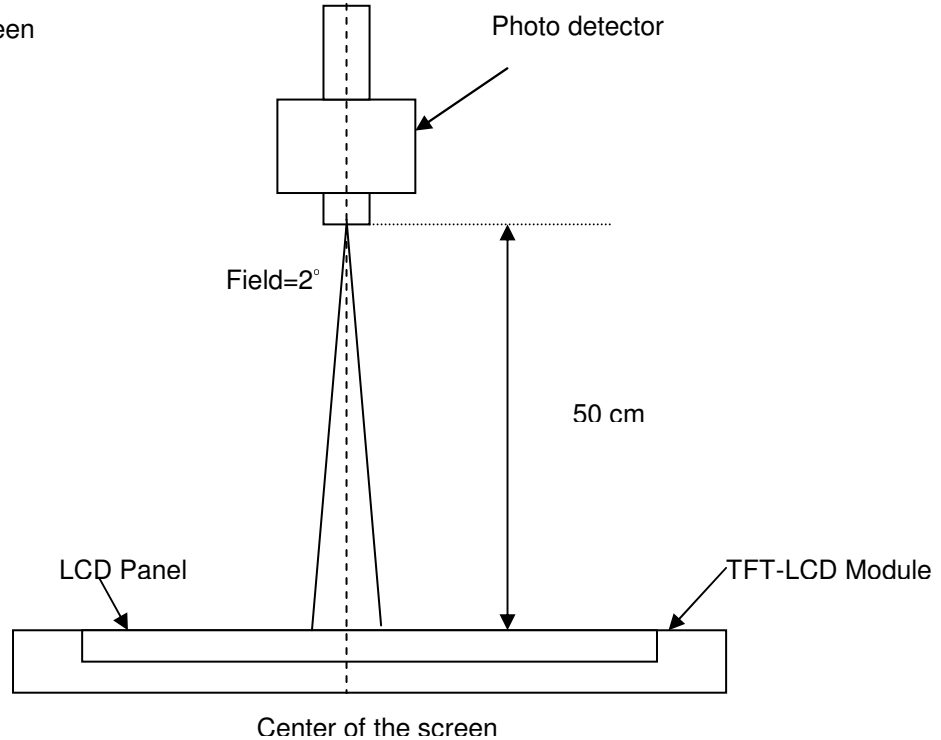

**Note 5:** Definition of Average Luminance of White ( $Y_L$ ):

Measure the luminance of gray level 63 at 5 points ,  $Y_L = [L (1)+ L (2)+ L (3)+ L (4)+ L (5)] / 5$   
 $L (x)$  is corresponding to the luminance of the point X at Figure in Note (1).

**Note 6:** Definition of contrast ratio:

Contrast ratio is calculated with the following formula.

$$\text{Contrast ratio (CR)} = \frac{\text{Brightness on the "White" state}}{\text{Brightness on the "Black" state}}$$



**Note 7:** Definition of Cross Talk (CT)

$$CT = |Y_B - Y_A| / Y_A \times 100 (\%)$$

Where

$Y_A$  = Luminance of measured location without gray level 0 pattern (cd/m<sup>2</sup>)

$Y_B$  = Luminance of measured location with gray level 0 pattern (cd/m<sup>2</sup>)

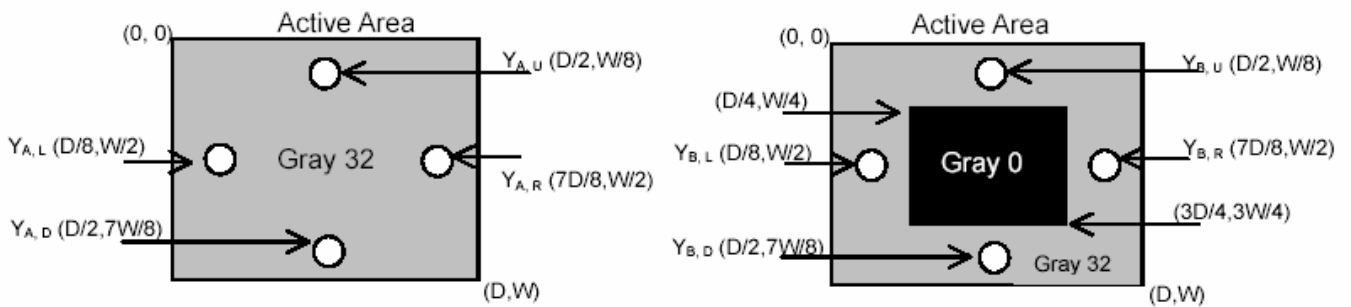

**Note 8:** Definition of response time:

The output signals of BM-7 or equivalent are measured when the input signals are changed from “Black” to “White” (falling time) and from “White” to “Black” (rising time), respectively. The response time interval between the 10% and 90% of amplitudes. Refer to figure as below.

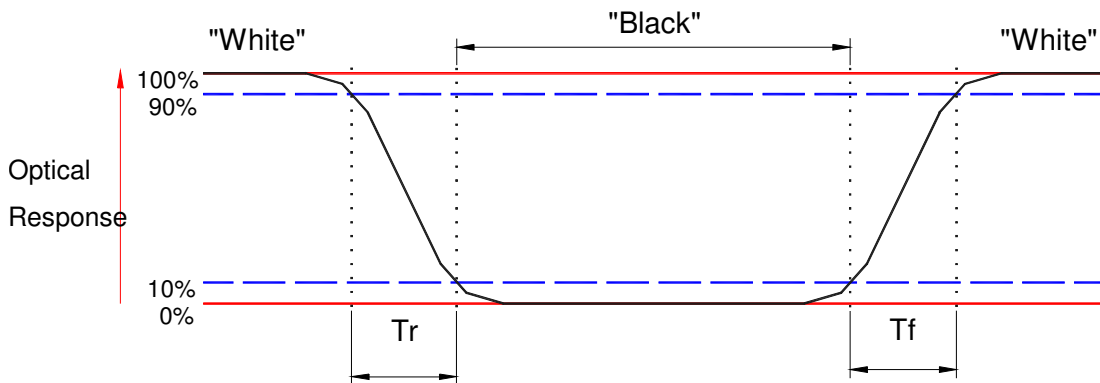

**Note 9:** Definition of viewing angle

Viewing angle is the measurement of contrast ratio  $\geq 10$ , at the screen center, over a  $180^\circ$  horizontal and  $180^\circ$  vertical range (off-normal viewing angles). The  $180^\circ$  viewing angle range is broken down as follows;  $90^\circ$  ( $\theta$ ) horizontal left and right and  $90^\circ$  ( $\Phi$ ) vertical, high (up) and low (down). The measurement direction is typically perpendicular to the display surface with the screen rotated about its center to develop the desired measurement viewing angle.

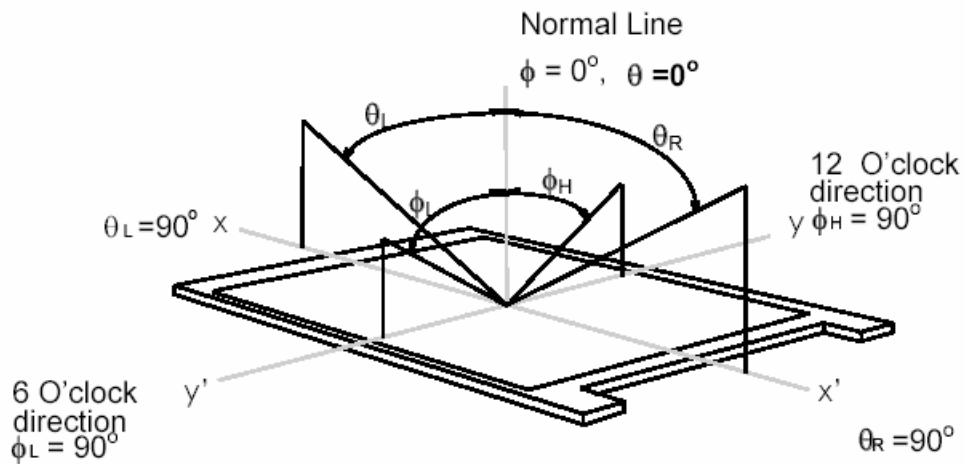

## 3. Functional Block Diagram

The following diagram shows the functional block of the 12.1 inches wide Color TFT/LCD Module with touch panel:

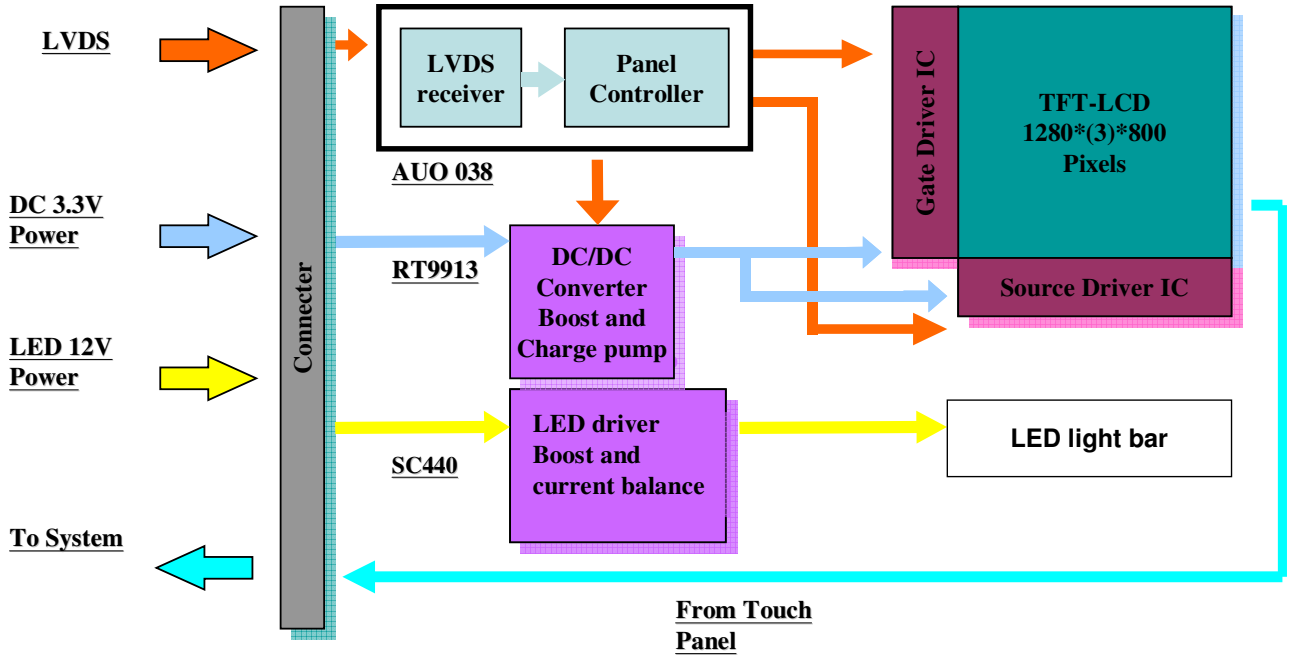

## 4. Absolute Maximum Ratings

Absolute maximum ratings of the module are as following:

### 4.1 Absolute Ratings of TFT LCD Module

Item	Symbol	Min	Max	Unit	Conditions
Logic/LCD Drive Voltage	VDD	-0.3	+4.0	[Volt]	Note 1,2

### 4.2 Absolute Ratings of Backlight Unit

Item	Symbol	Min	Max	Unit	Conditions
LED Current	ILED	-	20.0	[mA] rms	Note 1,2

### 4.3 Absolute Ratings of Environment

Item	Symbol	Min	Max	Unit	Conditions
Operating Temperature	TOP	0	+50	[°C]	Note 3
Operation Humidity	HOP	5	95	[%RH]	Note 3
Storage Temperature	TST	-20	+60	[°C]	Note 3
Storage Humidity	HST	5	95	[%RH]	Note 3

**Note 1:** At Ta (25°C)

**Note 2:** Permanent damage to the device may occur if exceed maximum values

**Note 3:** For quality performance, please refer to AUO IIS(Incoming Inspection Standard).

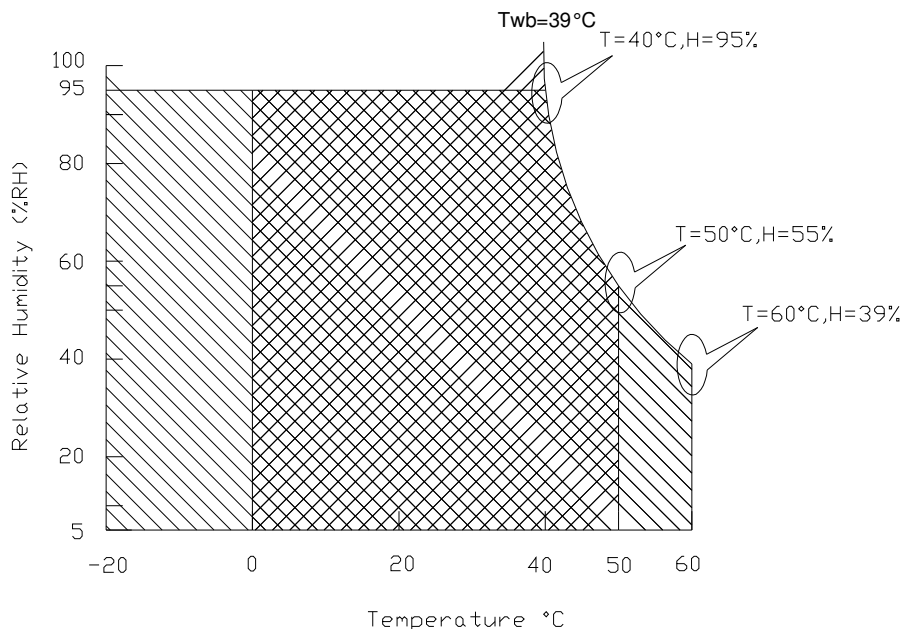

Operating Range



Storage Range

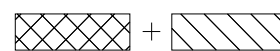

## 5. Electrical characteristics

### 5.1 TFT LCD Module

#### 5.1.1 Power Specification

Input power specifications are as follows;

Symble	Parameter	Min	Typ	Max	Units	Note
VDD	Logic/LCD Drive Voltage	3.0	3.3	3.6	[Volt]	
PDD	VDD Power		1.3	1.5	[Watt]	Note 1
IDD	IDD Current		400	420	[mA]	Note 1
IRush	Inrush Current			1800	[mA]	Note 2
VDDrp	Allowable Logic/LCD Drive Ripple Voltage			500	[mV] p-p	
VDDns	Allowable Logic/LCD Drive Ripple Noise			100	[mV] p-p	

**Note 1:** Maximum Measurement Condition : Black Pattern

**Note 2:** Measure Condition

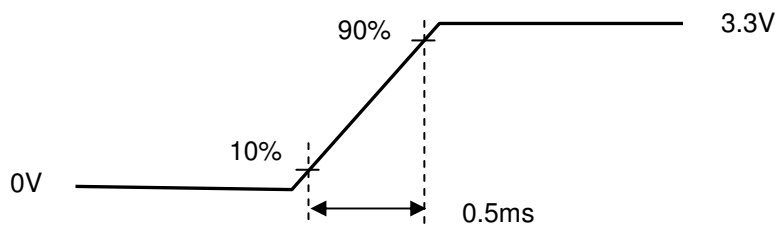
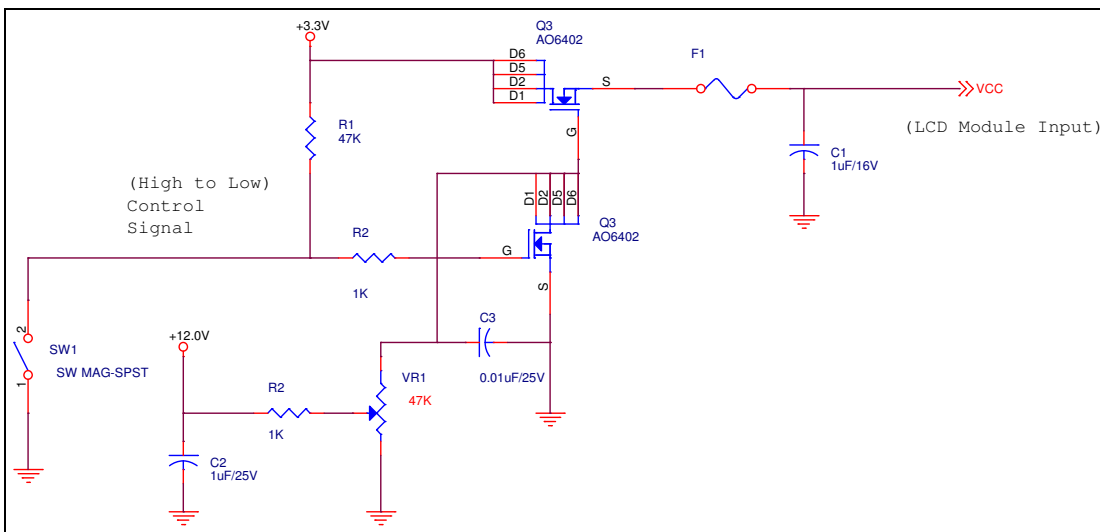

Vin rising time

### 5.1.2 Signal Electrical Characteristics

Input signals shall be low or High-impedance state when VDD is off.

Signal electrical characteristics are as follows;

Parameter	Condition	Min	Max	Unit
V <sub>th</sub>	Differential Input High Threshold (V <sub>cm</sub> =+1.2V)		100	[mV]
V <sub>tl</sub>	Differential Input Low Threshold (V <sub>cm</sub> =+1.2V)	-100		[mV]
V <sub>cm</sub>	Differential Input Common Mode Voltage	0.3	2.2	[V]

**Note:** LVDS Differential Voltage

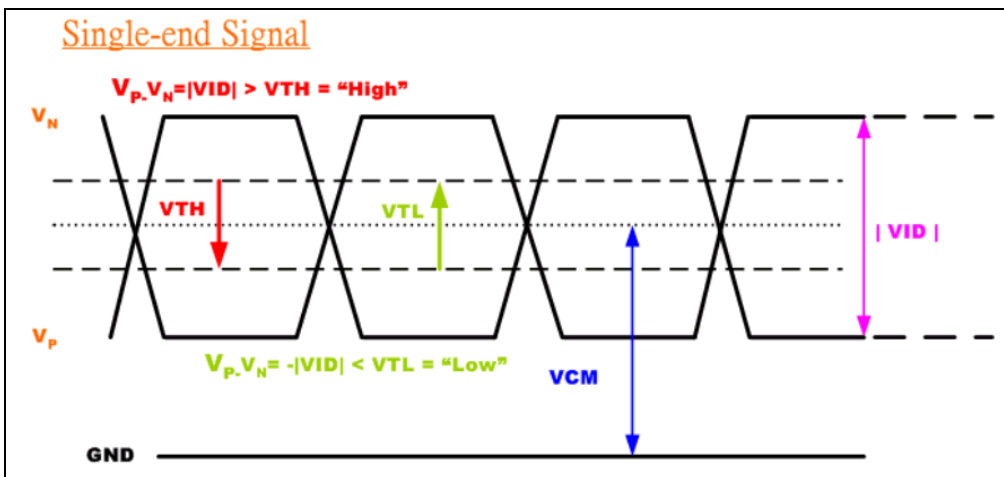

### 5.2 Backlight Unit

Parameter guideline for LED Inverter

Parameter	Min	Typ	Max	Units	Condition
White Luminance 5 points average	200	220	-	[cd/m <sup>2</sup> ]	(Ta=25°C)
LED current(I <sub>LED</sub> )	18.8	20.0	21.2	[mA] rms	(Ta=25°C)
LED Frequency(F <sub>LED</sub> )	-	800	-	[KHz]	(Ta=25°C)
LED Voltage (Reference) (V <sub>LED</sub> )	3.0	3.2	3.3	[Volt] rms	(Ta=25°C)
LED Power consumption (P <sub>LED</sub> ) @ 20.0 mA	-	3.6	4.0	[Watt]	(Ta=25°C) (Including circuit driving loss)

New???

LED Parameter guideline for LED driving selection (Ref. Remark 1)

Parameter	Symbol	Min	Typ	Max	Units	Condition
LED Forward Voltage	V <sub>F</sub>	2.95	3.15	3.35	[Volt]	(Ta=25°C)
LED Forward Current	I <sub>F</sub>		20	30	[mA]	(Ta=25°C)
LED Power consumption	P <sub>LED</sub>		3.78		[Watt]	(Ta=25°C) Note 1
LED Life-Time	N/A	10,000	-	-	Hour	(Ta=25°C) I <sub>F</sub> =20 mA Note 2
Output PWM frequency	F <sub>PWM</sub>	180	200	220	Hz	
Duty ratio	--	20	--	100	%	

**Note 1:** Calculator value for reference  $I_F \times V_F = P$

**Note 2:** The LED life-time define as the estimated time to 50% degradation of initial lu

## 6. Signal Characteristic

### 6.1 Pixel Format Image

Following figure shows the relationship of the input signals and LCD pixel format.

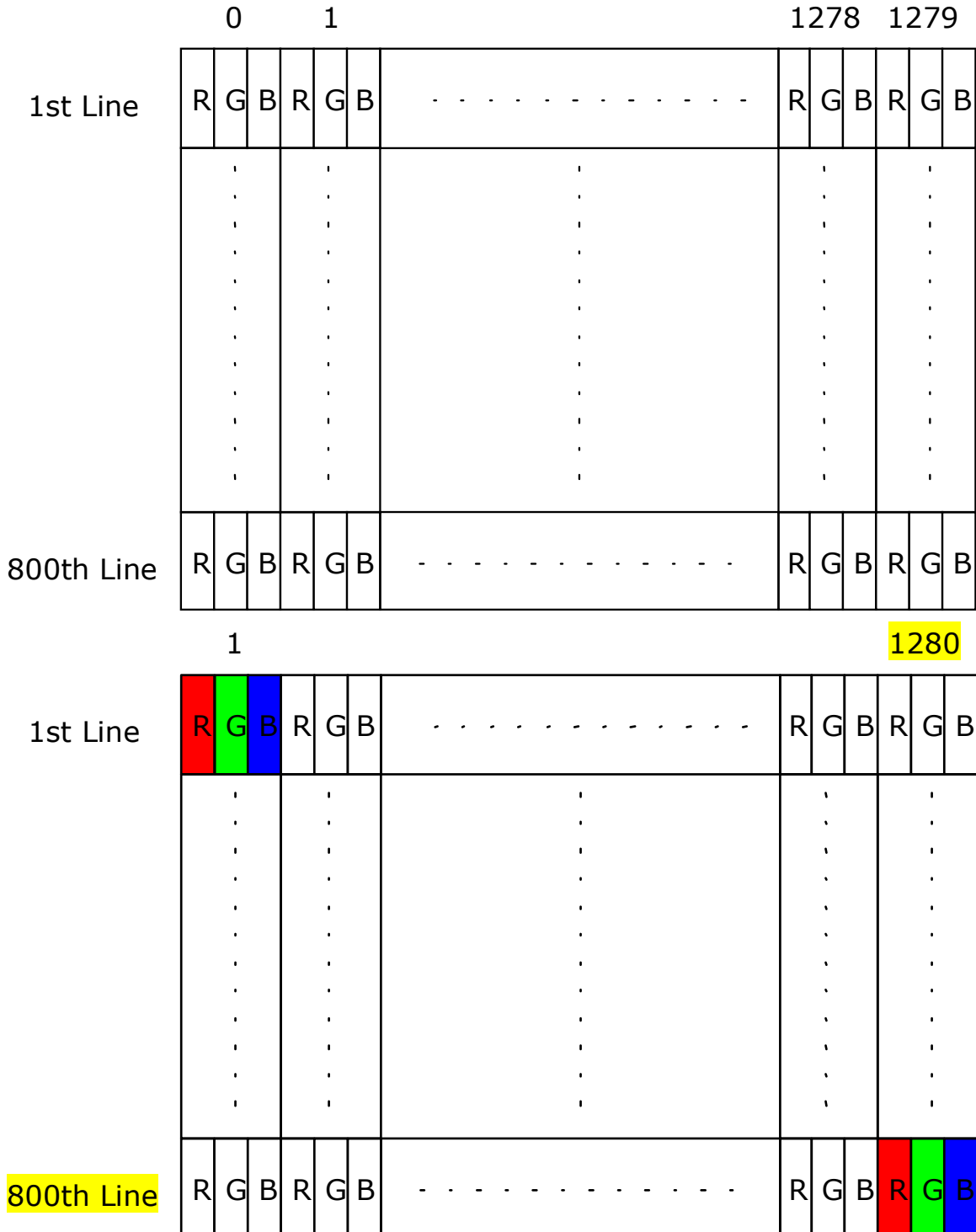



### 6.2 The input data format

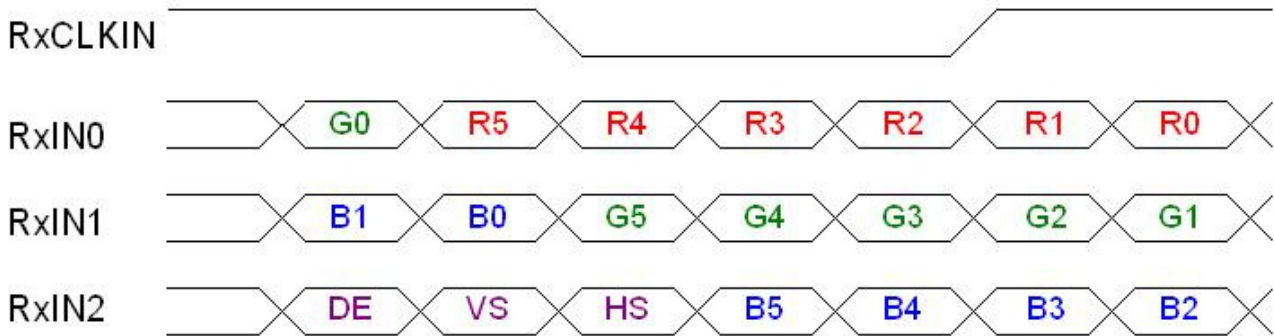

Signal Name	Description	
+RED5 (R5) +RED4 (R4) +RED3 (R3) +RED2 (R2) +RED1 (R1) +RED0 (R0)	Red Data 5 (MSB) Red Data 4 Red Data 3 Red Data 2 Red Data 1 Red Data 0 (LSB) <b>(Red-pixel Data)</b>	Red-pixel Data Each red pixel's brightness data consists of these 6 bits pixel data.
+GREEN 5 (G5) +GREEN 4 (G4) +GREEN 3 (G3) +GREEN 2 (G2) +GREEN 1 (G1) +GREEN 0 (G0)	Green Data 5 (MSB) Green Data 4 Green Data 3 Green Data 2 Green Data 1 Green Data 0 (LSB) <b>(Green-pixel Data)</b>	Green-pixel Data Each green pixel's brightness data consists of these 6 bits pixel data.
+BLUE 5 (B5) +BLUE 4 (B4) +BLUE 3 (B3) +BLUE 2 (B2) +BLUE 1 (B1) +BLUE 0 (B0)	Blue Data 5 (MSB) Blue Data 4 Blue Data 3 Blue Data 2 Blue Data 1 Blue Data 0 (LSB) <b>(Blue-pixel Data)</b>	Blue-pixel Data Each blue pixel's brightness data consists of these 6 bits pixel data.
-DTCLK	<b>Data Clock</b>	The typical frequency is 71.1 MHz. The signal is used to strobe the pixel data and DSPTMG signals. All pixel data shall be valid at the falling edge when the DSPTMG signal is high.
DSPTMG (DE)	<b>Display Timing</b>	This signal is stored at the falling edge of -DTCLK. When the signal is high, the pixel data shall be valid to be displayed.
VSYNC (VS)	<b>Vertical Sync</b>	The signal is synchronized to -DTCLK .
HSYNC (HS)	<b>Horizontal Sync</b>	The signal is synchronized to -DTCLK .

Note: Output signals from any system shall be low or High-impedance state when VDD is off.

### 6.3 Signal Description/Pin Assignment

LVDS (CN1) is a differential signal technology for LCD interface and high speed data transfer device.

Pin	Signal Name	Pin	Signal Name
1	KSO18	2	BAT2_LED
3	BAT2_LED	4	BREATH_PWRLED
5	KSI0	6	KSI1
7	DCP_SW	8	POWER_SD
9	GND	10	AUD_DMIC_CLK_G
11	AUC_DMIC_IN0	12	GND
13	LCD_ACLK+_MCH	14	LCD_ACLK-_MCH
15	GND	16	LCD_A2+_MCH
17	LCD_A2-_MCH	18	GND
19	LCD_A1+_MCH	20	LCD_A1-_MCH
21	GND	22	LCD_A0+_MCH
23	LCD_A0-_MCH	24	GND
25	LDDC_DATA_MCH	26	LDDC_CLK_MCH
27	LCD_TST	28	3V3_RUN
29	LCDVDD	30	LCDVDD

LED driving connector (CN2) provides the interface between system and LCD for control and power of LED BLU.

Pin	Signal Name	Pin	Signal Name
1	LCD_SMBCLK_LCD	2	LCD_SMBDAT_LCD
3	GND	4	BT_LED
5	LED_WLAN_OUT	6	HDD_LED
7	GND	8	KSI7
9	FP_RESET	10	3V3_ALW
11	3V3_RUN	12	3V3_Ntrig
X 13	3V3_Ntrig	14	KSI6
15	KSI5	16	KSI4
17	GND	18	USBP3_D-
19	USBP3_D+	20	GND
21	USBP5_D-	22	USBP5_D+
23	INVERTER_CBL_DET	24	GND
25	BIA_PWM_R	26	NC
27	GFX_PWR_SRC	28	GFX_PWR_SRC
29	GFX_PWR_SRC	30	GFX_PWR_SRC



# Product Specification

---

## B121EW10 V1

Pin assignment for CN3.

Pin	Signal Name
1	NC
2	GND
3	GND
4	USB+
5	USB-
6	GND
7	GND
8	GND
9	NC
10	3.3V
11	3.3V
12	3.3V

Pin assignment for CN4.

Pin	Signal Name
1	USB5_D-
2	USB5_D+
3	FP_RESET
4	+3.3V RUN
5	NC
6	GND

**Note1:** Start from right side

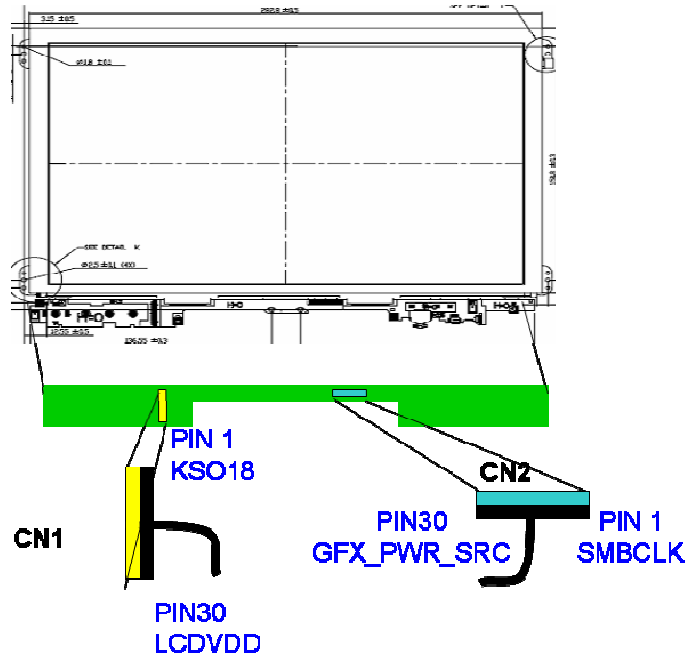

**Note2:** Input signals shall be low or High-impedance state when VDD is off.  
Internal circuit of LVDS inputs are as following.

The module uses a 100ohm resistor between positive and negative data lines of each receiver input

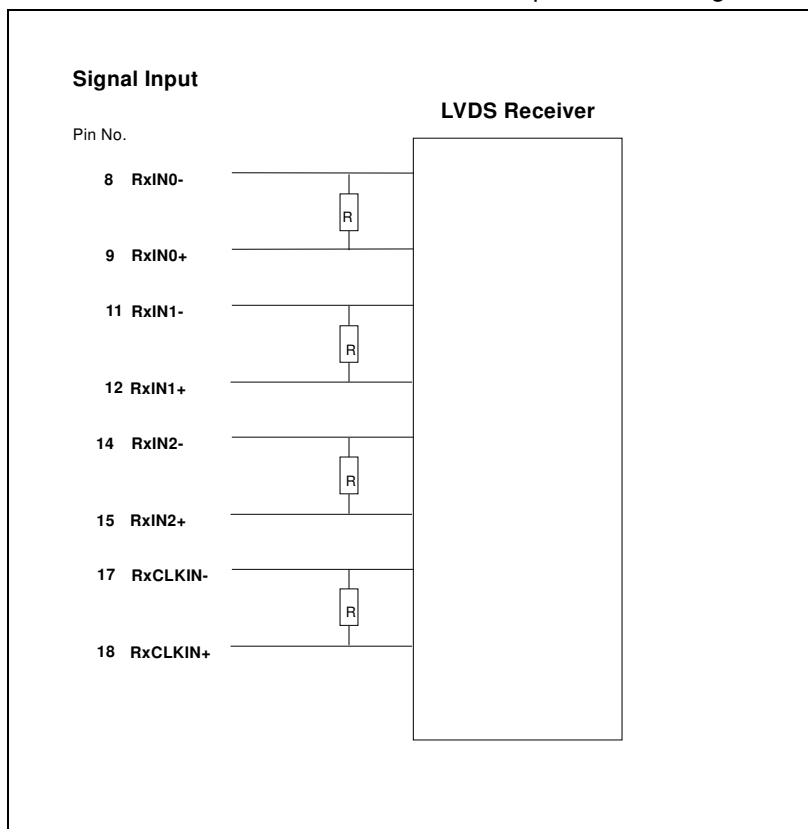

## 6.4 Interface Timing

### 6.4.1 Timing Characteristics

Basically, interface timings should match the 1280x800 /60Hz manufacturing guide line timing.

Parameter	Symbol	Min.	Typ.	Max.	Unit	
Frame Rate	-		60	-	Hz	
Clock frequency	$1/T_{Clock}$		71.1		MHz	
Vertical Section	Period	$T_V$	803	823	1023	$T_{Line}$
	Active	$T_{VD}$	800	800	800	
	Blanking	$T_{VB}$	3	23	223	
Horizontal Section	Period	$T_H$	1303	1440	2047	$T_{Clock}$
	Active	$T_{HD}$	1280	1280	1280	
	Blanking	$T_{HB}$	23	160	767	

**Note:** DE mode only

### 6.4.2 Timing diagram

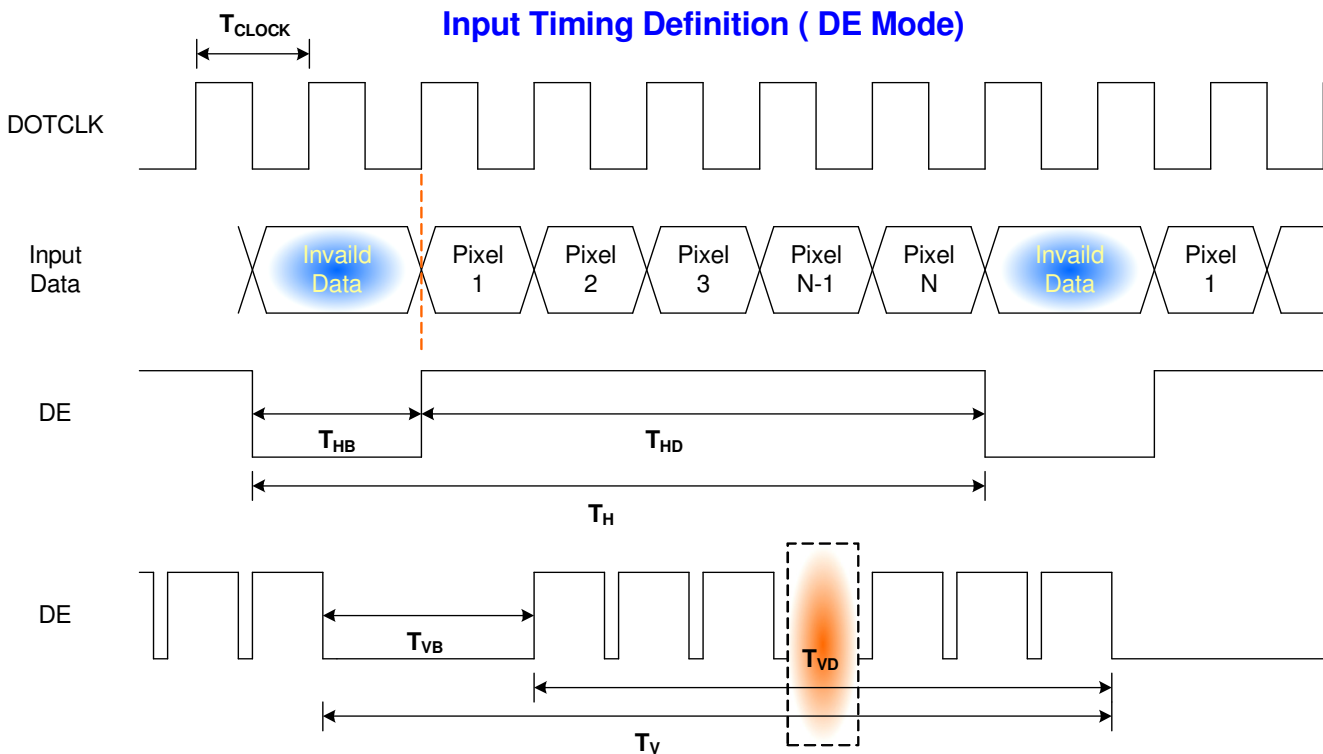

### 6.5 Power ON/OFF Sequence

VDD power and lamp on/off sequence is as follows. Interface signals are also shown in the chart. Signals from any system shall be Hi-Z state or low level when VDD is off.

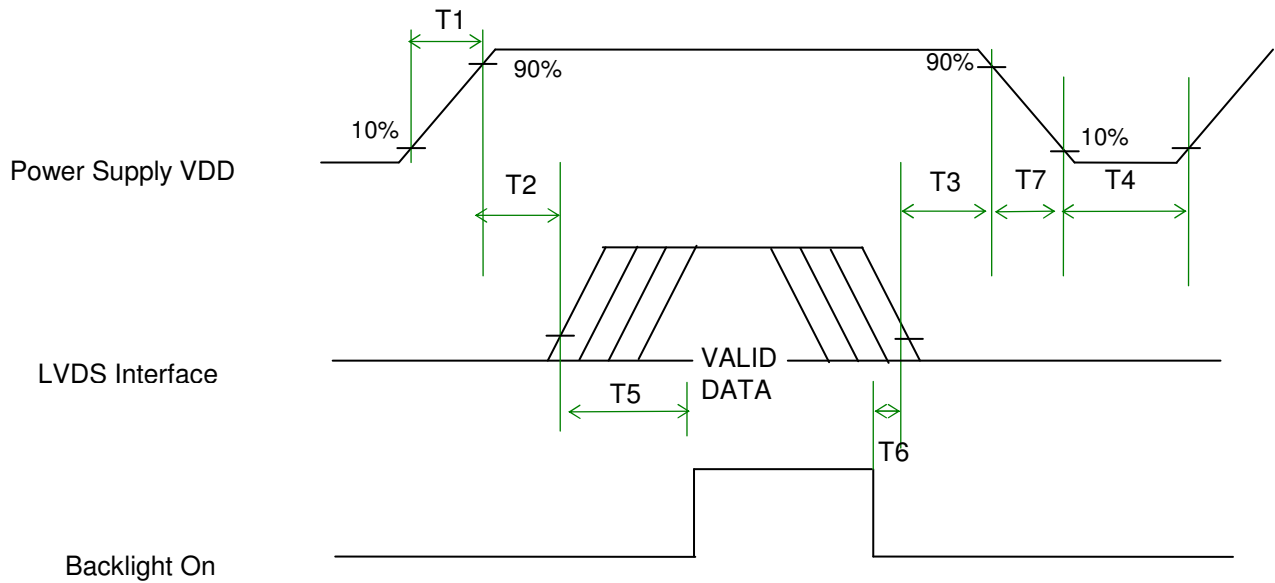

### Power Sequence Timing

Parameter	Value			Units
	Min.	Typ.	Max.	
T1	0.5	-	10	(ms)
T2	0	-	50	(ms)
T3	0	-	50	(ms)
T4	400	-	-	(ms)
T5	200	-	-	(ms)
T6	200	-	-	(ms)
T7	0	-	10	(ms)

**LED on/off sequence is as follows. Interface signals are also shown in the chart.**

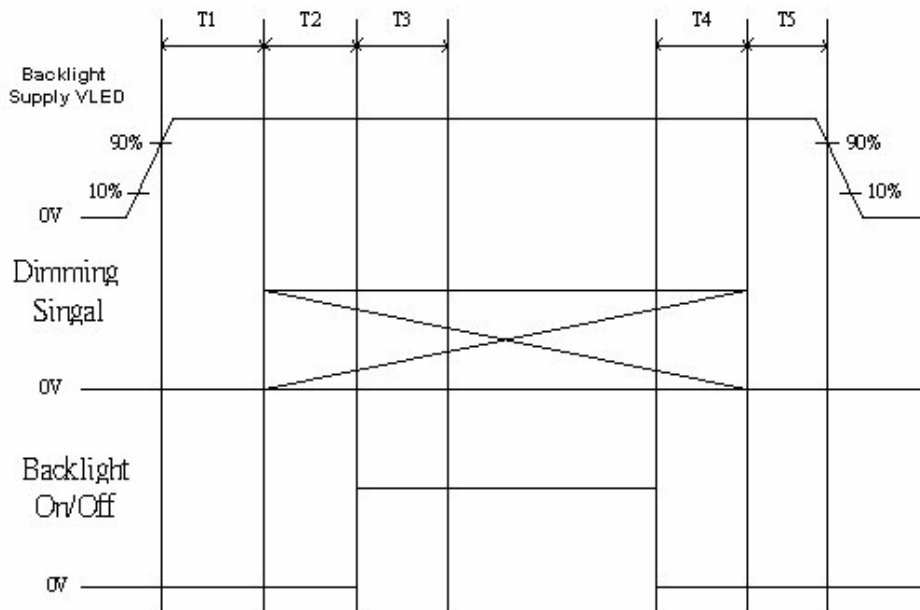

Symbol	Values			Unit
	Min	Typ	Max	
<b>T1</b>	10	---	---	ms
<b>T2</b>	10	---	---	
<b>T3</b>	50	---	---	
<b>T4</b>	0	---	---	
<b>T5</b>	10	---	---	

Note: The duty of LED dimming signal should be more than 20% in T2 and T3.

### 7. Digitizer Specification

This section defines the performance specification of N-trig Dual Mode Digitizer in standard room condition, 25±2°C, 50-60% RH, sea-level, and non-condensing. N-trig device Id is NTR001 with strengthen glass (SG). Operation system of customer must be Microsoft WHQL certificated Windows XP or Windows Vista. The interface between Digitizer and customer system is USB 2.0 full speed, 12 Mbps compliant.

Subject	Unit	Description	Note
Resolution	dpi	1000	
Position report rate	PPS	133	
Coordinate accuracy (average)	mm	±0.4	1
Coordination jitter (max.)	mm	±0.4	1
Light transmittance	%	92±4	2
Light reflection	%	≤7	3
Haze	%	7±3	
Surface hardness	--	3H min	4
Operation voltage	V	3.3±0.15	
Operation current	mA	500 (Max)	
Power consumption	mW	470 (typ.)	

**Note 1:** Vertical held pen at contact with Digitizer surface.

**Note 2:** Transmittance is measured by using BYK Gardner haze-gard plus.

**Note 3:** Reflection is measured at 550nm.

**Note 4:** Surface hardness measurement method follows JIS K5400.

#### 7.1.1 Operation mode

Mode	Description
Pen	Only pen input is possible. Completely palm rejection.
Touch	Only finger touch commands are allowed. Pen is ignored.
Auto	Pen in-range has automatic overriding priority which switches to pen mode and turns on palm rejection. A double-tap finger gesture turns the digitizer from Pen state to Touch state.
Dual	Dual mode activates both Touch and Pen state concurrently. This mode is applicable and activated in Windows Vista only.





### 7.1.2 Touch

Subject	Unit	Description
Technology	--	Digital Capacitive, input by finger only
Contact	--	Single point of contact
Actuation force	--	No force required
Minimum actuation diameter	Mm	4
Functions	--	Click, right click (via Press and Hold)
Palm rejection	--	Active while using the pen

### 7.1.3 Stylus

Stylus, a pen-like tool to activate Pen Function of digitizer, is not included in this specification. By using assigned model of Stylus, DS01-P091000B0, this digitizer can support function of Hover, Click, side switch button, i.e. right-click or eraser.

## 8. Connector Description

Physical interface is described as for the connector on module.

These connectors are capable of accommodating the following signals and will be following components.

<b>Connector Name / Designation</b>	<b>LVDS (CN1)/ LED BLU (CN2)</b>
Manufacturer	JAE
Type / Part Number	JAE FI-J30S-VF15N
Mating Housing/Part Number	JAE FI-J30C3
Mating Contact/Part Number	JAE FI-J30C3

CN3, CN4, and CN401 connect PCB to Digitizer, Bio-feature sensor, and LED stripe, respectively. The mating ends of these connectors are FPC.

<b>Connector Name / Designation</b>	<b>Digitizer (CN3)</b>
Manufacturer	Molex
Type / Part Number	54550-1271

<b>Connector Name / Designation</b>	<b>Bio-Feature sensor (CN4)</b>
Manufacturer	Molex
Type / Part Number	51441-0672

<b>Connector Name / Designation</b>	<b>PCBA to LED stripe (CN401)</b>
Manufacturer	Hirose
Type / Part Number	FH19SC-8S-0.5SH(05)

## 9. Vibration and Shock Test

### 9.1 Vibration Test

**Test Spec:**

- Test method: Non-Operation
- Acceleration: 1.5G , sine wave
- Frequency: 10 - 500Hz Random
- Sweep: 0.5 octave/minute in each of three mutually perpendicular axes.

### 9.2 Shock Test Spec:

**Test Spec:**

- Test method: Non-Operation
- Acceleration: 180 G , Half sine wave
- Active time: 2 ms
- Pulse: Half sine wave

### 10. Reliability

Subject	Description
Operating High Temperature	+50°C ,Dynamic ,250hr ,Humidity 20%
Operating Low Temperature	0°C ,Dynamic ,250hr ,Humidity 20%
Storage High Temperature	+65°C ,Non_Operating ,250hr ,Humidity 20%
Storage Low Temperature	-20°C ,Non_Operating ,250hr
High Temp &High Humidity	+40°C ,Dynamic ,Humidity 95% ,250hr
Temperature Cycling Non-Operating	-40°C to +65°C ,Ramp< 20°C /min, Duration at Temp. = 30 min, Test Cycles =50
Altitude	Op(0~14000 ft) Non-op (0~40000ft)
MTBF	200K hrs
Storage Shock	180g's, 2.0 ms, Half Sine Wave ± 3 Axis ( +X, -X, +Y, -Y, +Z, -Z) 1Shocks per Direction
Storage Vibration	1.5 Grms, 30 min/side, PSD Spectrum Break Points, 26 Hz G2/Hz=0.316, 50 Hz G2/Hz=0.007, 222 Hz G2/Hz=0.0018, 500Hz G2/Hz=0.0001
ESD	Contact : ±8 KV Air : ±15 KV

**Note1:** According to EN61000-4-2, ESD class B: Some performance degradation allowed. No data lost. Self-recoverable. No hardware failures.

**Note2:** MTBF (Excluding the LED): 20,000 hours with a confidence level 90%.

## 11. Mechanical Characteristics

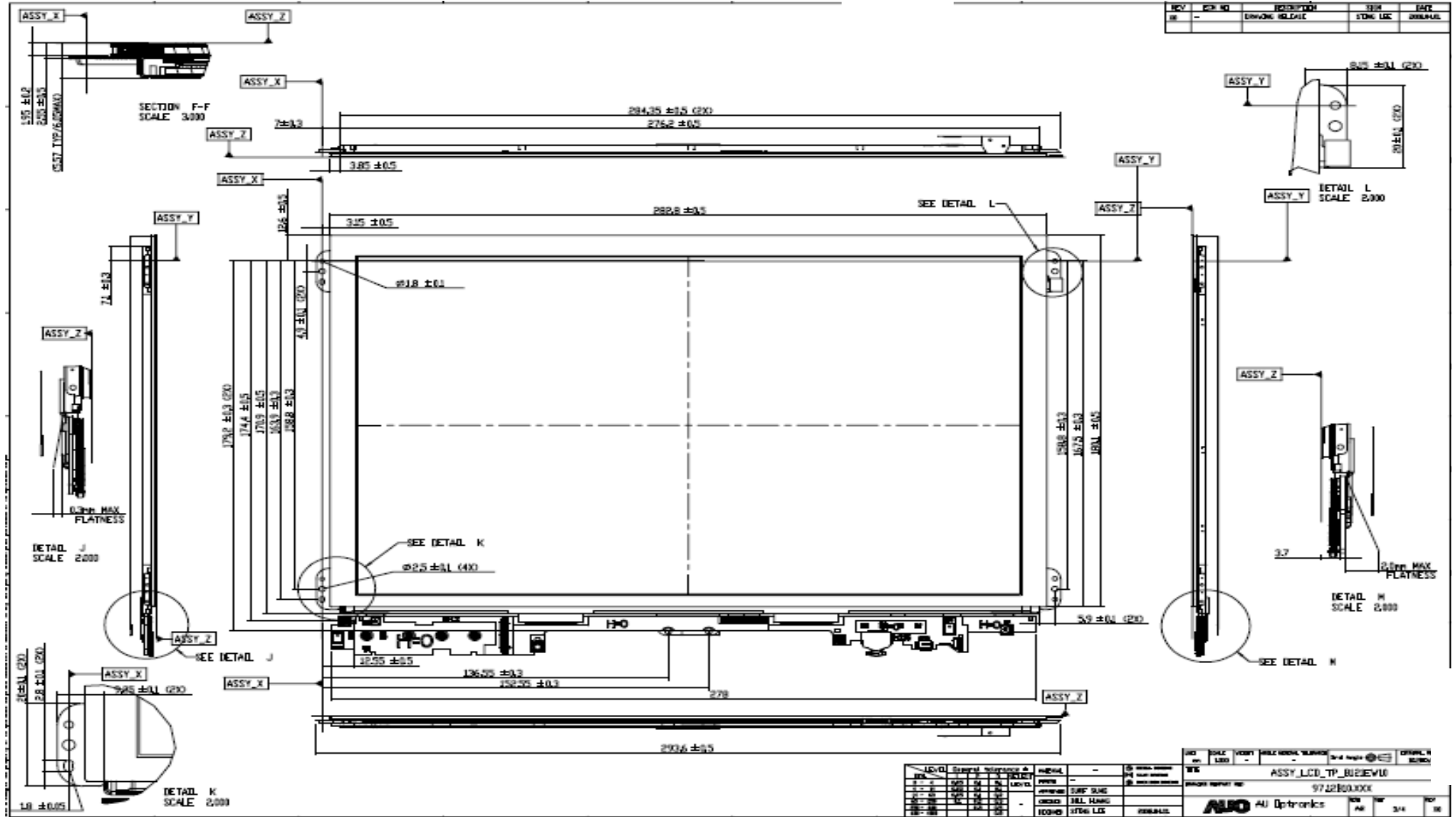

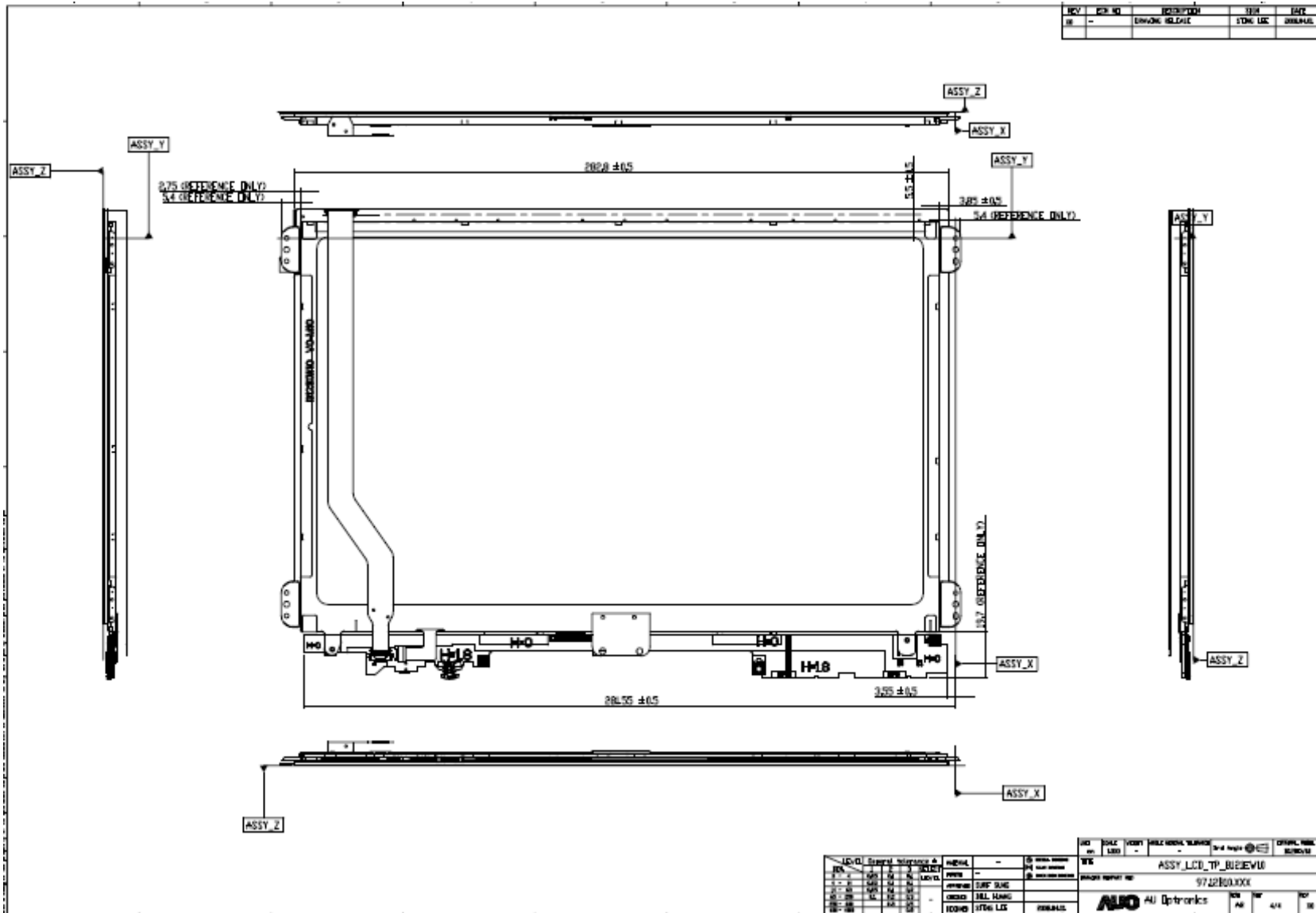

REV	REV. NO.	DESCRIPTION	DATE	BY
01	-	ISSUING RELEASE	1706 LXC	0000000

REV	REV. NO.	DESCRIPTION	DATE	BY
01	-	ISSUING RELEASE	1706 LXC	0000000

NO.	SOLE	UNIT	DATE	REVISION	DATE	BY
01	01	01	1706	01	1706	01

NO.	SOLE	UNIT	DATE	REVISION	DATE	BY
01	01	01	1706	01	1706	01

NO.	SOLE	UNIT	DATE	REVISION	DATE	BY
01	01	01	1706	01	1706	01

NO.	SOLE	UNIT	DATE	REVISION	DATE	BY
01	01	01	1706	01	1706	01

## 12. Shipping and Package

### 12.1 Shipping Label Format

AUO LCD S/N Label: This label records the model name, firmware/ hardware version, manufacture date, and serial number of the LCD in AUO.



Revision Code (YYY) Tabel:

Build Name(s):	PPID Revision Code(s):
Sub System Test (SST) Working Sample (WS) ENG 2	X00, X01, X02, ..., X0n
Product Test (PT) Engineering Sample (ES) ENG 3	X10, X11, X12, ..., X1n
System Test (ST) Customer Sample (CS) ENG 4	X20, X21, X22, ... X2n
X-Build (XB) Mass Production (MP) ENG 5	A00, A01, A02, ... A0n

Carton label: This label is pasted on the carton to identify the quantity in each carton, Dell part number, and manufacture date.



## 12.2. Carton package

The outside dimension of carton is 423(L)mm\* 374(W)mm\* 335(H)mm, carton and cushion weight are 1800g. Maximum quantity of each carton is 20 pcs LCD.



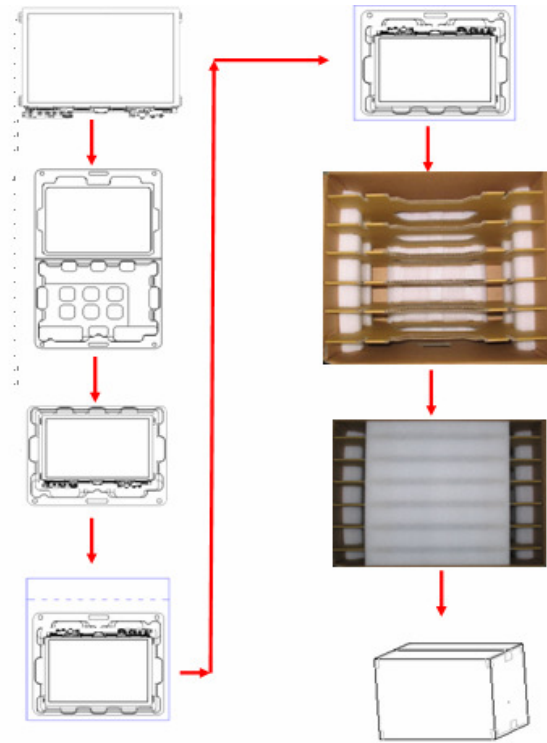

## 12.3 Shipping package of palletizing

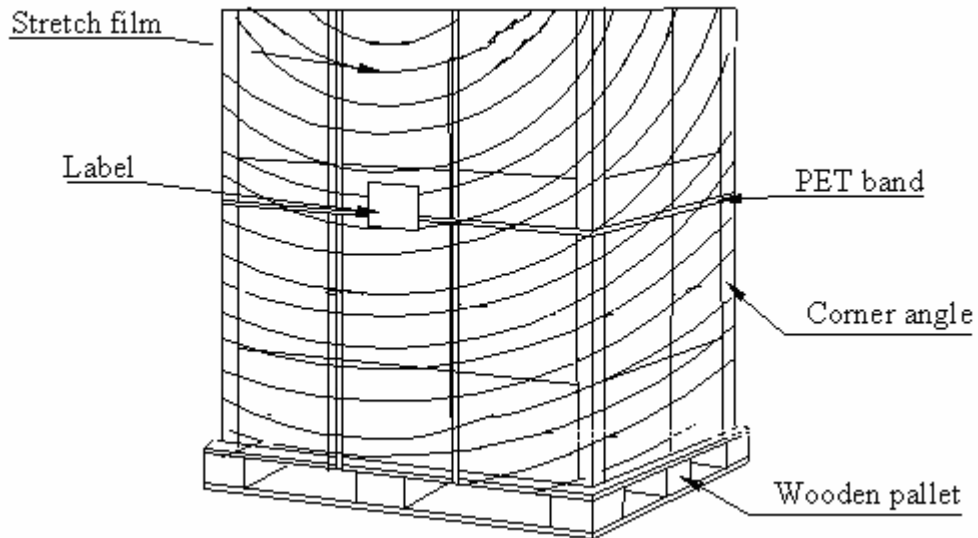



## 13. Appendix: EDID description