

<b>B40S ... B500S</b> <b>SMD Single Phase Bridge Rectifier</b> <b>SMD Einphasen-Brückengleichrichter</b>	<b>I<sub>FAV</sub> = 1.0 A</b> <b>V<sub>F</sub> &lt; 1.1 V</b> <b>T<sub>jmax</sub> = 150°C</b>	<b>V<sub>RRM</sub> = 80...1000 V</b> <b>I<sub>FSM</sub> = 45/50 A</b> <b>t<sub>tr</sub> ~ 1500 ns</b>
--	--	---

Version 2019-01-04

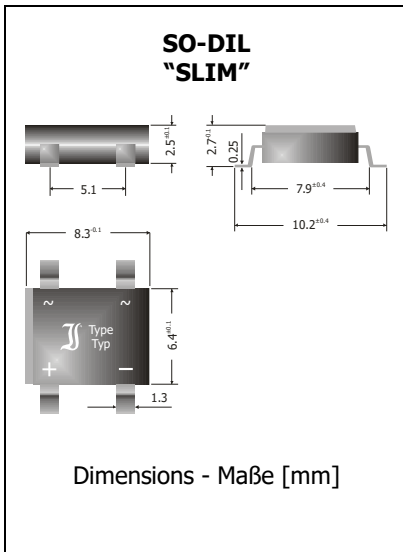

**Typical Applications**  
 50/60 Hz Mains Rectification,  
 Power Supplies  
 Commercial grade <sup>1)</sup>

**Features**  
 UL recognized, File E175067  
 Slim Profile 2.5 mm  
 Compliant to RoHS, REACH,  
 Conflict Minerals <sup>1)</sup>

**Mechanical Data <sup>1)</sup>**

Taped and reeled	1500 / 13 <sup>''</sup>
Weight approx.	0.4 g
Case material	UL 94V-0
Solder & assembly conditions	260°C/10s MSL = 1



**Typische Anwendungen**  
 50/60 Hz Netzgleichrichtung,  
 Stromversorgungen  
 Standardausführung <sup>1)</sup>

**Besonderheiten**  
 UL-anerkannt, Liste E175067  
 Schlanke Bauhöhe 2.5 mm  
 Konform zu RoHS, REACH,  
 Konfliktmineralien <sup>1)</sup>

**Mechanische Daten <sup>1)</sup>**

Gegurtet auf Rolle
Gewicht ca.
Gehäusematerial
Löt- und Einbaubedingungen

**Maximum ratings <sup>2)</sup>**

**Grenzwerte <sup>2)</sup>**

Type Typ	Part No. Artikel-Nr.	Max. alternating input voltage Max. Eingangswchelspannung V <sub>VRMS</sub> [V] <sup>3)</sup>	Repetitive peak reverse voltage Periodische Spitzensperrspannung V <sub>RRM</sub> [V] <sup>4)</sup>
B40S	B40S-SLIM	40	80
B80S	B80S-SLIM	80	160
B125S	B125S-SLIM	125	250
B250S	B250S-SLIM	250	600
B380S	B380S-SLIM	380	800
B500S	B500S-SLIM	500	1000

Max. rectified output current Dauergrenzstrom am Brückenausgang	R-load C-load	T <sub>A</sub> = 50°C	I <sub>FAV</sub>	1.0 A <sup>5)</sup> 0.8 A <sup>5)</sup>
Repetitive peak forward current Periodischer Spitzenstrom		f > 15 Hz	I <sub>FRM</sub>	9A <sup>5)</sup>
Peak forward surge current Stoßstrom in Fluss-Richtung	Half sine-wave Sinus-Halbwellen	50 Hz (10 ms) 60 Hz (8.3 ms)	I <sub>FSM</sub>	45 A 50 A
Rating for fusing Grenzlastintegral		t < 10 ms	i <sup>2</sup> t	10.1 A <sup>2</sup> s
Operating junction temperature – Sperrschichttemperatur Storage temperature – Lagerungstemperatur			T <sub>j</sub> T <sub>s</sub>	-50...+150°C -50...+150°C

1 Please note the [detailed information on our website](#) or at the beginning of the data book  
 Bitte beachten Sie die [detaillierten Hinweise auf unserer Internetseite](#) bzw. am Anfang des Datenbuches  
 2 T<sub>A</sub> = 25°C unless otherwise specified – T<sub>A</sub> = 25°C wenn nicht anders angegeben  
 3 Eventual superimposed voltage peaks must not exceed V<sub>RRM</sub> – Evtl. überlagerte Spannungsspitzen dürfen V<sub>RRM</sub> nicht überschreiten  
 4 Valid per Diode – Gültig pro Diode  
 5 Mounted on P.C. Board with 13 x 13 mm<sup>2</sup> copper pads – Montage auf Leiterplatte mit 13 x 13 mm<sup>2</sup> Kupferbelag (Löt pads)

**Characteristics**

**Kenwerte**

Forward voltage Durchlass-Spannung	$T_j = 25^\circ\text{C}$	$I_F = 1\text{ A}$	$V_F$	$< 1.1\text{ V}^{1)}$
Leakage current Sperrstrom	$T_j = 25^\circ\text{C}$	$V_R = V_{RRM}$	$I_R$	$< 5\ \mu\text{A}^{1)}$
Reverse recovery time Sperrverzug	$I_F = 0.5\text{ A}$ through/über $I_R = 1\text{ A}$ to $I_R = 0.25\text{ A}$		$t_{rr}$	typ. $1500\text{ ns}^{1)}$
Typical junction capacitance – Typische Sperrschichtkapazität		$V_R = 4\text{ V}$	$C_j$	$25\text{ pF}^{1)}$
Typical thermal resistance junction to ambient (per device) Typischer Wärmewiderstand Sperrschicht – Umgebung (pro Bauteil)			$R_{thA}$	$40\text{ K/W}^{2)}$
Typical thermal resistance junction to terminal (per device) Typischer Wärmewiderstand Sperrschicht – Anschluss (pro Bauteil)			$R_{thT}$	$15\text{ K/W}$

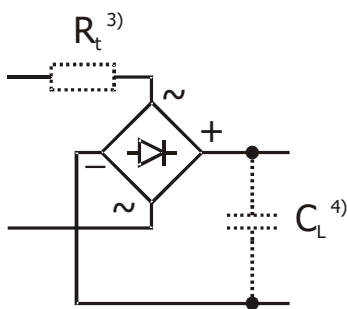

Type Typ	Recomm. protective resistance Empf. Schutzwiderstand $R_t [\Omega]^{3)}$	Admiss. load capacitor at $R_t$ Zul. Ladekondensator mit $R_t$ $C_L [\mu\text{F}]^{4)}$
B40S	1.7	2900
B80S	3.5	1400
B125S	5.5	900
B250S	13.3	350
B380S	17.7	280
B500S	22.2	220

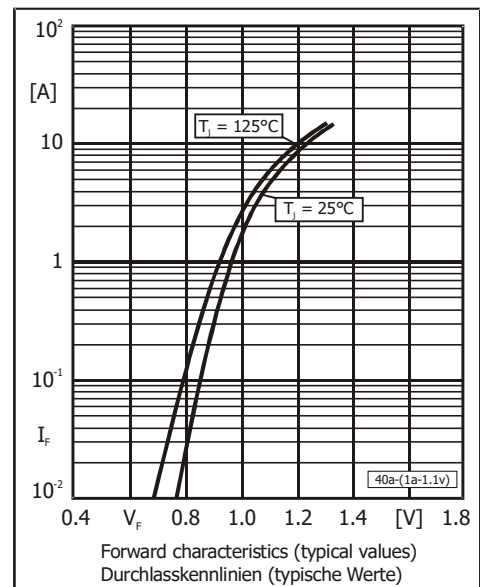
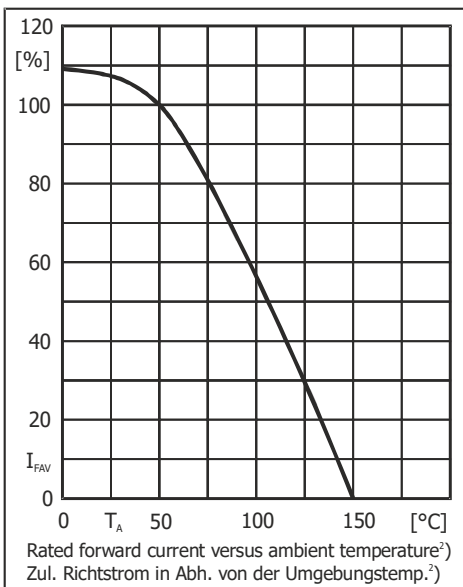

**Disclaimer:** See data book page 2 or [website](#)  
**Haftungsausschluss:** Siehe Datenbuch Seite 2 oder [Internet](#)

- 1 Valid per Diode – Gültig pro Diode
- 2 Mounted on P.C. Board with 13 x 13 mm<sup>2</sup> copper pads – Montage auf Leiterplatte mit 13 x 13 mm<sup>2</sup> Kupferbelag (Löt pads)
- 3  $R_t = V_{RRM} / I_{FSM}$   $R_t$  is the equivalent resistance of any protective element which ensures that  $I_{FSM}$  is not exceeded  
 $R_t$  ist der Ersatzwiderstand eines jeglichen Schutzelementes, welches ein Überschreiten von  $I_{FSM}$  verhindert
- 4  $C_L = 5\text{ ms} / R_t$  If the  $R_t C_L$  time constant is less than a quarter of the 50Hz mains period,  $C_L$  can be charged completely in a single half wave of the mains. Hence,  $I_{FSM}$  occurs as a single pulse only!  
Falls die  $R_t C_L$  Zeitkonstante kleiner ist als  $1/4$  der 50Hz-Netzperiode, kann  $C_L$  innerhalb einer einzigen Netzhalbwellen komplett geladen werden.  $I_{FSM}$  tritt dann nur als Einzelpuls auf!