



Product Specification

AU OPTRONICS CORPORATION

() Preliminary Specifications

(V) Final Specifications

Module	13.1" FHD 16:9 Color TFT-LCD with LED Backlight design
Model Name	B131HW02 V0 (H/W:0A)
Note	<i>LED Backlight with driving circuit design</i>

Customer	Date
Checked & Approved by	Date
<p>Note: This Specification is subject to change without notice.</p>	

Approved by	Date
<u>WesHsiang Lo</u>	<u>2011/11/04</u>
Prepared by	Date
<u>Michael WJ Sun</u>	<u>2011/11/04</u>
NBBU Marketing Division AU Optronics corporation	



Product Specification

AU OPTRONICS CORPORATION

Contents

1. Handling Precautions	4
2. General Description.....	5
2.1 General Specification	5
2.2 Optical Characteristics.....	6
3. Functional Block Diagram.....	11
4. Absolute Maximum Ratings	12
4.1 Absolute Ratings of TFT LCD Module.....	12
4.2 Absolute Ratings of Environment	12
5. Electrical Characteristics	13
5.1 TFT LCD Module	13
5.2 Backlight Unit.....	14
6. Signal Interface Characteristic	14
6.1 Pixel Format Image	14
6.2 Integration Interface Requirement	15
6.3 Interface Timing.....	17
6.4 Power ON/OFF Sequence	19
7. Panel Reliability Test.....	20
7.1 Reliability Test	20
8. Mechanical Characteristics	21
8.1 LCM Outline Dimension	21
9. Shipping and Package	23
9.1 Shipping Label Format	23
9.2 Carton Package.....	24
9.3 Shipping Package of Palletizing Sequence	25
10. Appendix.....	26
10.1 EDID Description	26



Product Specification

AU OPTRONICS CORPORATION

Record of Revision

Version and Date	Page	Old description	New Description	Remark
0.1 2010/09/01	All	First Edition for Customer		
0.2 2010/10/18	26	Old EDID setting	New EDID setting	Revised
1.0 2010/12/17	All	N/A	Final Spec	
1.1 2011/08/30	5	Glass Thickness: 0.5mm	Glass Thickness: 0.21mm*2=0.42mm	Revised
1.2 2011/11/04	12		Max Current capacity = 4.0A	
1.2 2011/11/04	12		Max LED input reverse voltage = 5V	
1.2 2011/11/04	12		Max LED input forward current = 30mA	



Product Specification

AU OPTRONICS CORPORATION

1. Handling Precautions

- 1) Since front polarizer is easily damaged, pay attention not to scratch it.
- 2) Be sure to turn off power supply when inserting or disconnecting from input connector.
- 3) Wipe off water drop immediately. Long contact with water may cause discoloration or spots.
- 4) When the panel surface is soiled, wipe it with absorbent cotton or other soft cloth.
- 5) Since the panel is made of glass, it may break or crack if dropped or bumped on hard surface.
- 6) Since CMOS LSI is used in this module, take care of static electricity and insure human earth when handling.
- 7) Do not open nor modify the Module Assembly.
- 8) Do not press the reflector sheet at the back of the module to any directions.
- 9) At the insertion or removal of the Signal Interface Connector, be sure not to rotate nor tilt the Interface Connector of the TFT Module.
- 11) After installation of the TFT Module into an enclosure (Notebook PC Bezel, for example), do not twist nor bend the TFT Module even momentarily. At designing the enclosure, it should be taken into consideration that no bending/twisting forces are applied to the TFT Module from outside. Otherwise the TFT Module may be damaged.
- 12) Small amount of materials having no flammability grade is used in the LCD module. The LCD module should be supplied by power complied with requirements of Limited Power Source (IEC60950 or UL1950), or be applied exemption.
- 13) Disconnecting power supply before handling LCD modules, it can prevent electric shock, DO NOT TOUCH the electrode parts, cables, connectors and LED circuit part of TFT module that a LED light bar build in as a light source of back light unit. It can prevent electrostatic breakdown.



Product Specification

AU OPTRONICS CORPORATION

2. General Description

B131HW02 V0 is a Color Active Matrix Liquid Crystal Display composed of a TFT LCD panel, a driver circuit, and LED backlight system. The screen format is intended to support the 16:9 HD, 1920(H) x1080(V) screen and 16.7M colors (RGB 24-bits data driver) with LED backlight driving circuit. All input signals are display port interface compatible.

B131HW02 V0 is designed for a display unit of notebook style personal computer and industrial machine.

2.1 General Specification

The following items are characteristics summary on the table at 25 °C condition:

Items	Unit	Specifications			
Screen Diagonal	[mm]	331.76			
Active Area	[mm]	289.152X162.648			
Pixels H x V		1920x3(RGB) x 1080			
Pixel Pitch	[mm]	0.1506X0.1506			
Pixel Format		R.G.B. Vertical Stripe			
Display Mode		Normally White			
White Luminance (ILED=19mA) (Note: ILED is LED current)	[cd/m ²]	300 typ. (5 points average, gamma correction off) 210 min. (5 points average, gamma correction off)			
Luminance Uniformity		1.82 max. (9 points)			
Contrast Ratio		500 typ			
Response Time	[ms]	16 typ/ 30 Max (gamma correction off)			
Nominal Input Voltage VDD	[Volt]	+2.5 typ.			
Power Consumption	[Watt]	4.65 typ. (Include Logic and Blu power)			
Weight	[Grams]	158 typ.			
Physical Size Include bracket & PCBA	[mm]		Min.	Typ.	Max.
		Length	298.6	299.1	299.6
		Width	183.8	184.3	184.8
		Thickness		2.35	2.99
Electrical Interface		eDP 2Lane			
Glass Thickness	[mm]	0.21mm*2=0.42mm			
Surface Treatment		Anti-Glare, Hardness 4H,			



Product Specification

AU OPTRONICS CORPORATION

Support Color		16.7M colors (RGB 24-bit)
Temperature Range Operating	[°C]	0 to +50
Storage (Non-Operating)	[°C]	-20 to +60
RoHS Compliance		RoHS Compliance

2.2 Optical Characteristics

The optical characteristics are measured under stable conditions at 25°C (Room Temperature) :

Item	Symbol	Conditions	Min.	Typ.	Max.	Unit	Note
White Luminance I _{LED} =19mA		5 points average	210	300	-	cd/m ²	1, 4, 5.
Viewing Angle	θ_R	Horizontal (Right) CR = 10 (Left)	40	55	-	degree	4, 9
	θ_L		40	55	-		
	ϕ_H	Vertical (Upper) CR = 10 (Lower)	30	50	-		
	ϕ_L		40	55	-		
Luminance Uniformity	δ_{9P}	9 Points	-	-	1.82		2, 3, 4
Contrast Ratio	CR		300	500	-		4, 6
Cross talk	%				TBD		4, 7
Response Time	T_r	Rising	-	3	6	msec	4, 8
	T_f	Falling	-	13	24		
	T_{RT}	Rising + Falling	-	16	30		
Color / Chromaticity Coordinates	Red	Rx	CIE 1931	0.639	0.685	0.731	4
		Ry		0.283	0.338	0.394	
	Green	Gx		0.184	0.230	0.276	
		Gy		0.642	0.697	0.753	
	Blue	Bx		0.109	0.155	0.201	
		By		0.020	0.076	0.131	
	White	Wx		0.268	0.311	0.353	
		Wy		0.278	0.332	0.387	
Adobe	%		-	96	-		



Product Specification

AU OPTRONICS CORPORATION

Note 1: 5 points position (Ref: Active area)

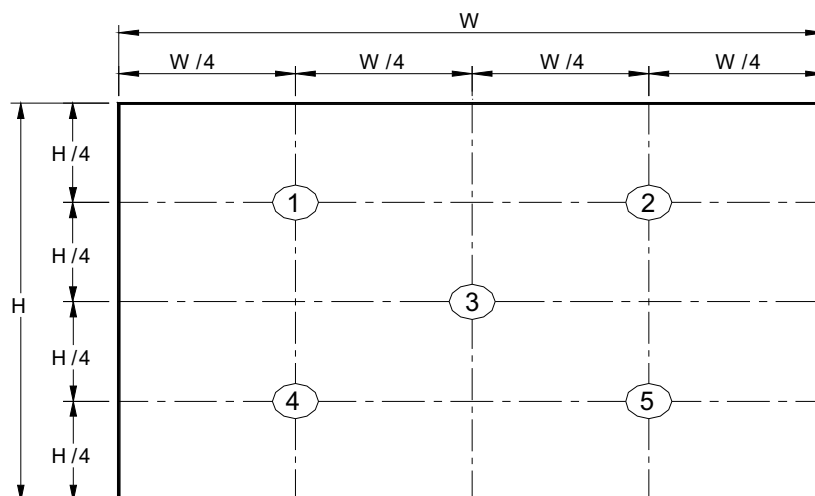

Note 2: 9 points position (Ref: Active area)

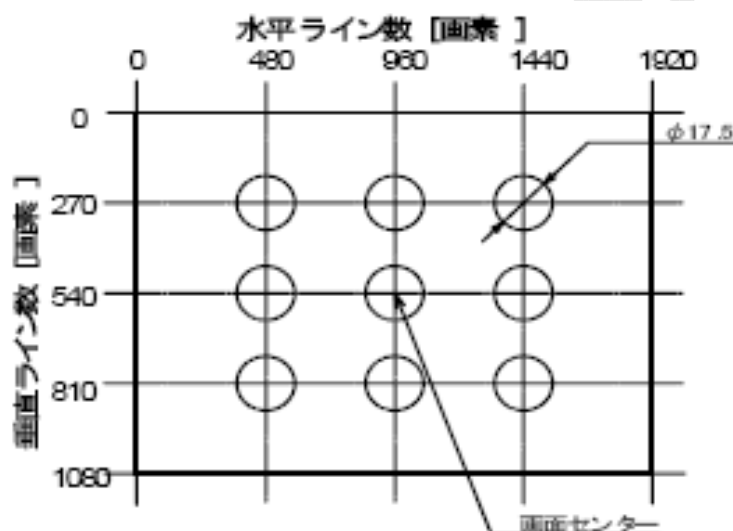

Note 3: The luminance uniformity of 5 or 9 points is defined by dividing the maximum luminance values by the minimum test point luminance

$$\delta_{w5} = \frac{\text{Maximum Brightness of five points}}{\text{Minimum Brightness of five points}}$$

$$\delta_{w9} = \frac{\text{Maximum Brightness of thirteen points}}{\text{Minimum Brightness of thirteen points}}$$

Note 4: Measurement method

The LCD module should be stabilized at given temperature for 30 minutes to avoid abrupt temperature change during measuring. In order to stabilize the luminance, the measurement should be executed after lighting Backlight for 60 minutes in a stable, windless and dark room, and it should be measured in the center



Product Specification

AU OPTRONICS CORPORATION

of screen.

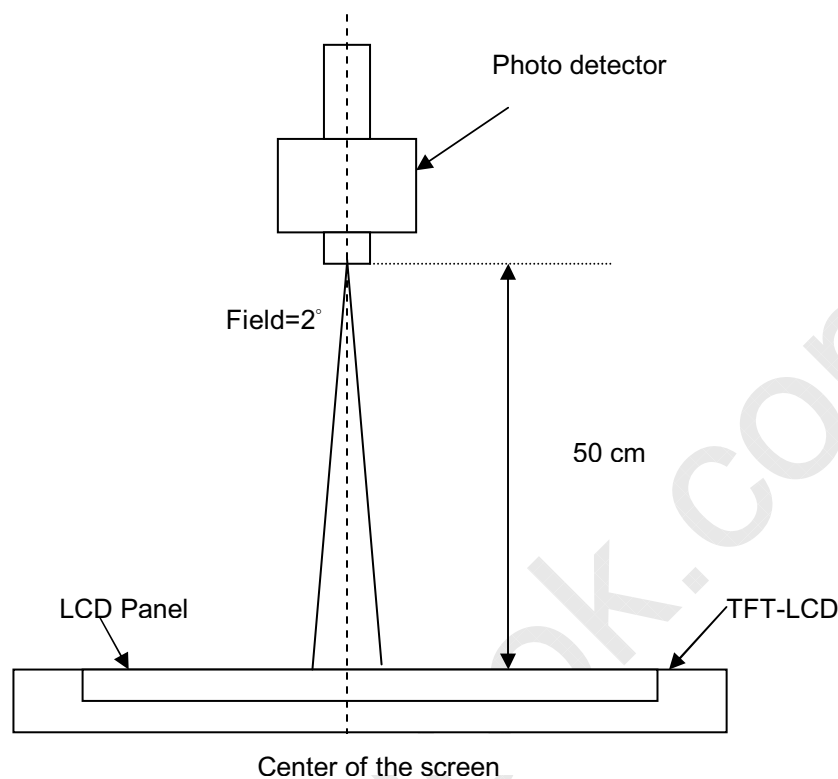

Note 5 : Definition of Average Luminance of White (Y_L):

Measure the luminance of gray level 63 at 5 points , $Y_L = [L (1)+ L (2)+ L (3)+ L (4)+ L (5)] / 5$

$L (x)$ is corresponding to the luminance of the point X at Figure in Note (1).

Note 6 : Definition of contrast ratio:

Contrast ratio is calculated with the following formula.

$$\text{Contrast ratio (CR)} = \frac{\text{Brightness on the "White" state}}{\text{Brightness on the "Black" state}}$$

Note 7 : Definition of Cross Talk (CT)

$$CT = | Y_B - Y_A | / Y_A \times 100 (\%)$$

Where

Y_A = Luminance of measured location without gray level 0 pattern (cd/m²)

Y_B = Luminance of measured location with gray level 0 pattern (cd/m²)



Product Specification

AU OPTRONICS CORPORATION

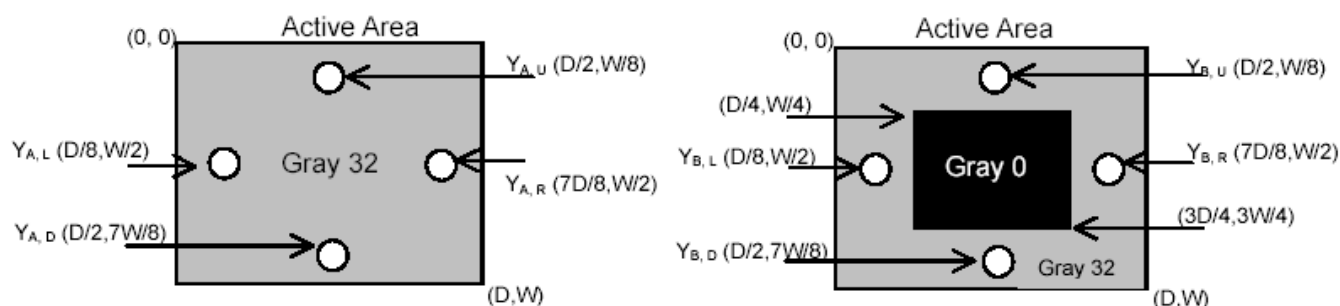

Note 8: Definition of response time:

The output signals of BM-7 or equivalent are measured when the input signals are changed from "Black" to "White" (falling time) and from "White" to "Black" (rising time), respectively. The response time interval between the 10% and 90% of amplitudes. Refer to figure as below.

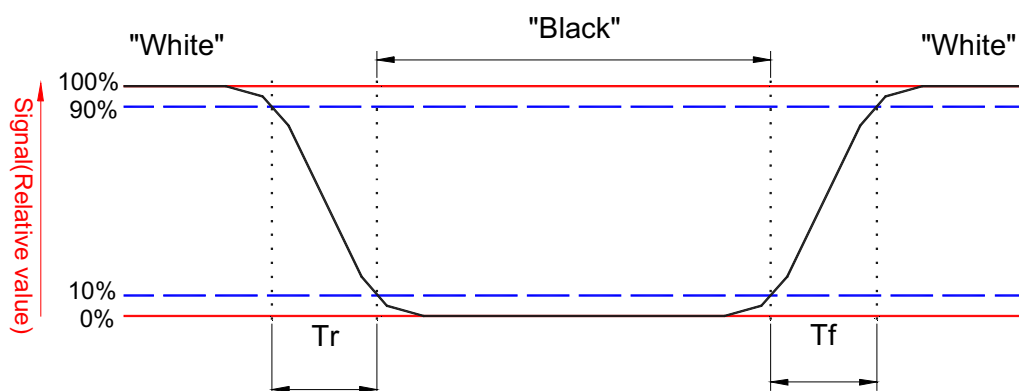



Product Specification

AU OPTRONICS CORPORATION

Note 9. Definition of viewing angle

Viewing angle is the measurement of contrast ratio ≥ 10 , at the screen center, over a 180° horizontal and 180° vertical range (off-normal viewing angles). The 180° viewing angle range is broken down as follows; 90° (θ) horizontal left and right and 90° (ϕ) vertical, high (up) and low (down). The measurement direction is typically perpendicular to the display surface with the screen rotated about its center to develop the desired measurement viewing angle.

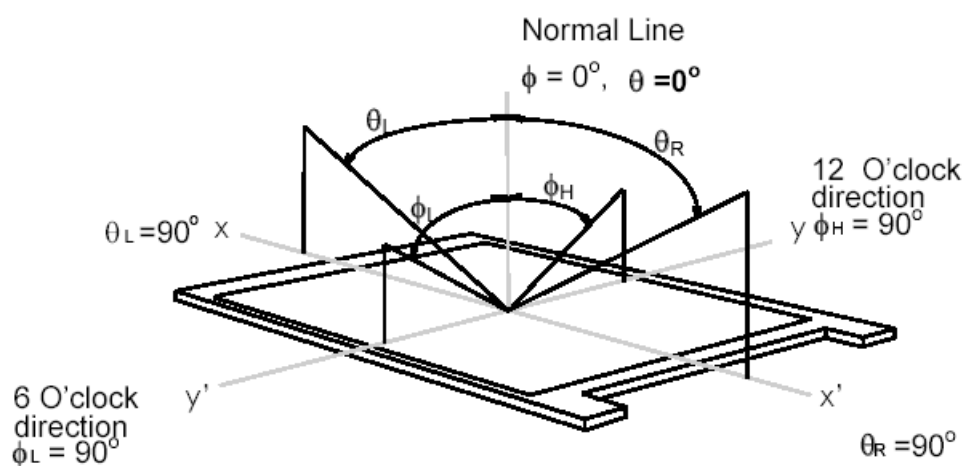



Product Specification

AU OPTRONICS CORPORATION

3. Functional Block Diagram

The following diagram shows the functional block of the 13.1 inches wide Color TFT/LCD.

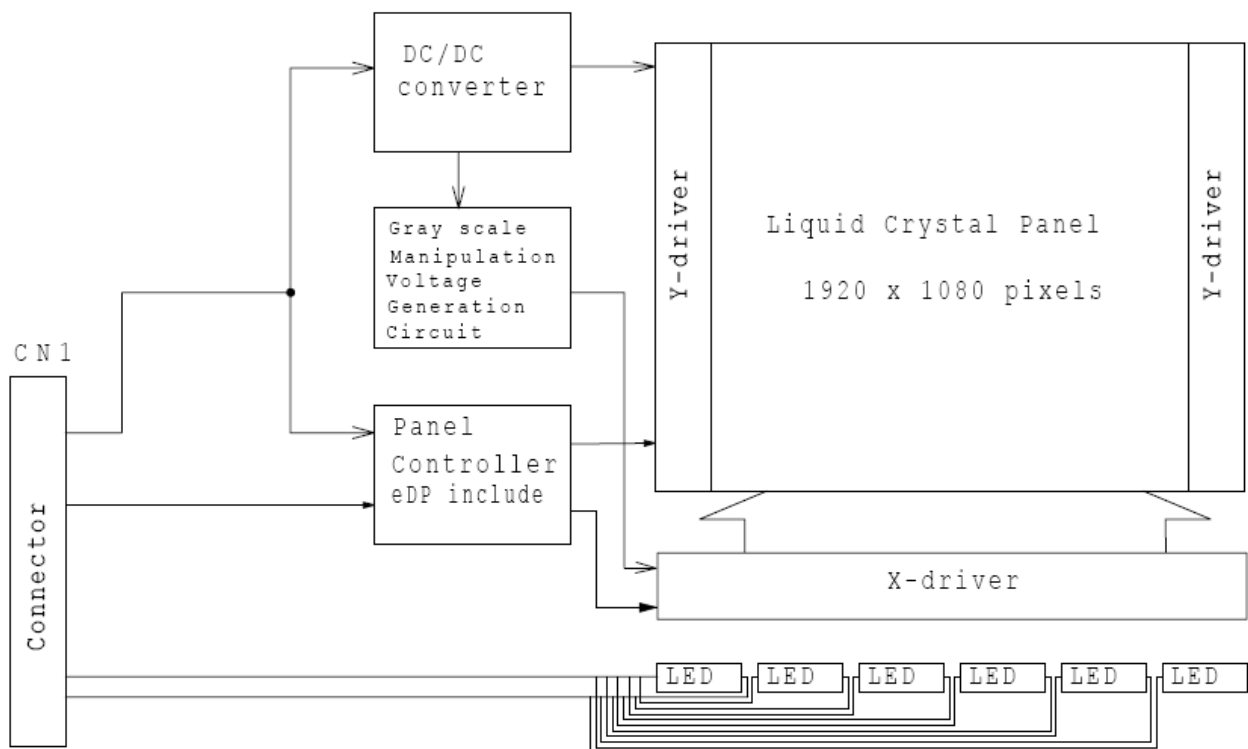



Product Specification

AU OPTRONICS CORPORATION

4. Absolute Maximum Ratings

An absolute maximum rating of the module is as following:

4.1 Absolute Ratings of TFT LCD Module

Item	Symbol	Min	Max	Unit	Conditions
Logic/LCD Drive	V _{in}	-0.3	+3.0	[Volt]	Note 1,2
Current capacity	IDD		4.0	[A]	
LED input reverse	V _{LED}		5	[Volt]	Note 1
LED input forward	I _{LED}		30	[mA]	Note 1

4.2 Absolute Ratings of Environment

Item	Symbol	Min	Max	Unit	Conditions
Operating Temperature	TOP	0	+50	[°C]	Note 4
Operation Humidity	HOP	10	90	[%RH]	Note 4
Storage Temperature	TST	-20	+60	[°C]	Note 4
Storage Humidity	HST	10	90	[%RH]	Note 4

Note 1: At Ta (25°C)

Note 2: Permanent damage to the device may occur if exceed maximum values

Note 3: LED specification refer to section 5.2

Note 4: For quality performance, please refer to IIS (Incoming Inspection Standard).

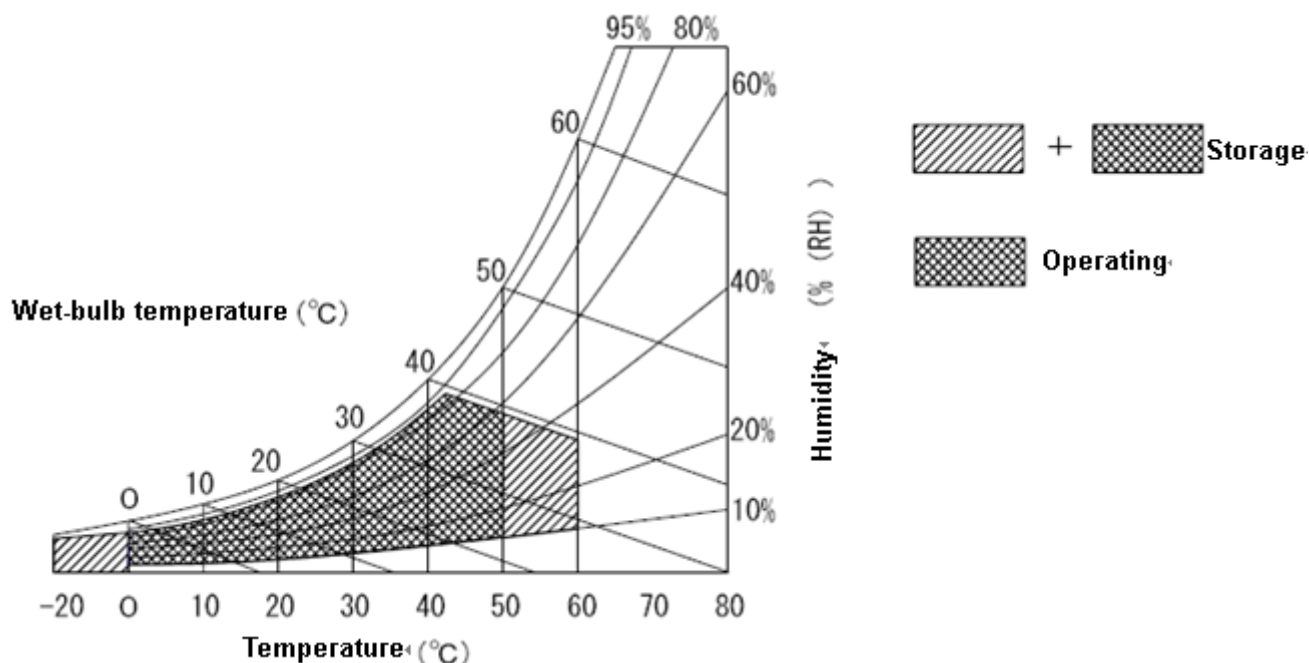



Product Specification

AU OPTRONICS CORPORATION

5. Electrical Characteristics

5.1 TFT LCD Module

5.1.1 Power Specification

Input power specifications are as follows;

The power specification are measured under 25°C and frame frequency under 60Hz

Symble	Parameter	Min	Typ	Max	Units	Note
VDD	Logic/LCD Drive Voltage	2.35	2.5	2.7	[Volt]	
PDD	VDD Power	-	1.13	1.38	[Watt]	Note 1
IDD	IDD Current	-	450	550	[mA]	Note 1

Note 1 : Display pattern

Item	Color
1.	White
2	Yellow
3	Purple
4	Red
5	Light Blue
6	Green
7	Blue
8	Black

1	2	3	4	5	6	7	8
---	---	---	---	---	---	---	---



Product Specification

AU OPTRONICS CORPORATION

5.2 Backlight Unit

5.2.1 LED characteristics

Parameter guideline for LED driving is under stable conditions at 25°C (Room Temperature):

Parameter	Symbol	Min.	Typ.	Max.	Unit	Condition
LED Operation Current	IRLED			19	[mA]	
Light Bar Operation Voltage (for reference)	VLB	-	31	34	[Volt]	Note 1
BLU Power consumption (for reference)	PLED	-	-	4.56	[Watt]	(Ta=25°C), Note 2 Vin =12V
LED life Time (Typical)	N/A	10,000	-	-	Hour	(Ta=25°C), Note 3 IF=20 mA

Note 1 : The value showed in the table is one light bar's operation voltage.

Note 2: Calculator value for reference PLED = Vf (Normal Distribution) * If (Normal Distribution) / Efficiency

Note 3 : The LED life-time define as the estimated time to 50% degradation of initial luminous.

6. Signal Interface Characteristic

6.1 Pixel Format Image

Following figure shows the relationship of the input signals and LCD pixel format.

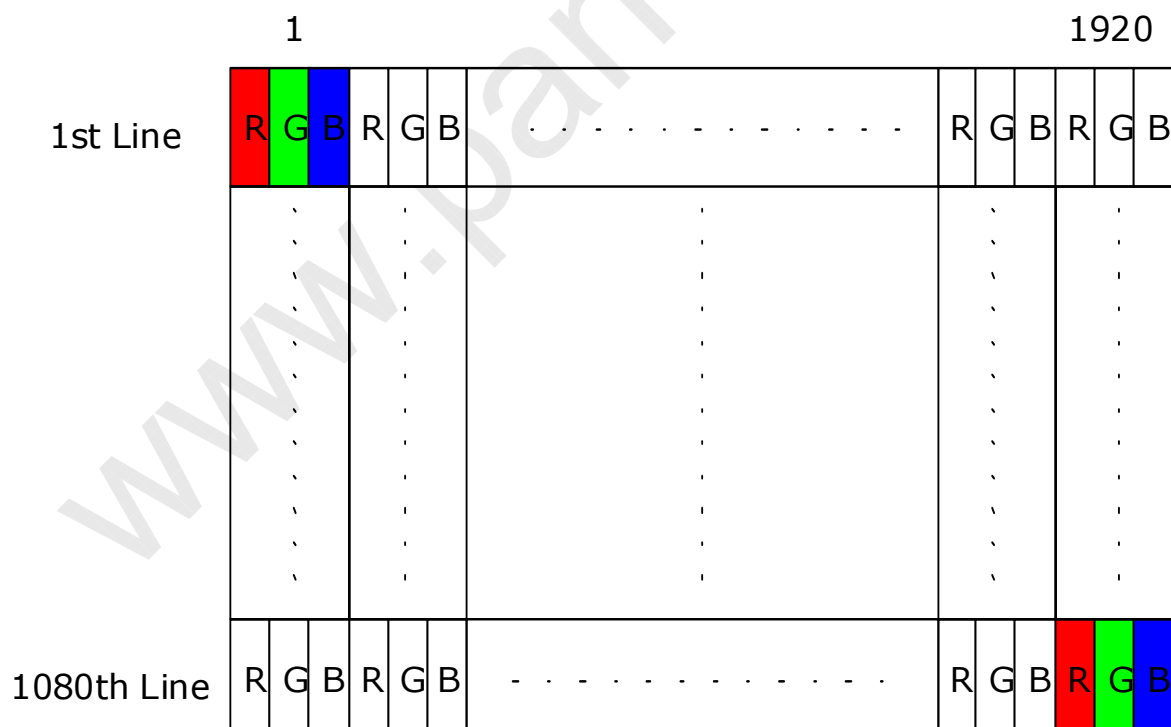



Product Specification

AU OPTRONICS CORPORATION

6.2 Integration Interface Requirement

6.2.1 Connector Description

Physical interface is described as for the connector on module.

These connectors are capable of accommodating the following signals and will be following components.

Connector Name / Designation	For Signal Connector
Manufacturer	I-PEX
Type / Part Number	20461-030E-12
Mating Housing/Part Number	20459-130T-10

6.2.2 Pin Assignment

CN1 INPUT SIGNAL (20461-030E-12 / I-PEX)

[Mating Connector :20459-130T-10 / I-PEX]

Terminal No.	Symbol	Function
1	HPD	HPD signal pin
2	NC	Non-Connection
3	Lane1-	Comp Signal Link Lane1
4	Lane1+	True Signal Link Lane1
5	Lane0-	Comp Signal Link Lane0
6	Lane0+	True Signal Link Lane0
7	AUX-	True Signal Auxiliary Ch.
8	AUX+	Comp Signal Auxiliary Ch.
9	NC	Non-Connection
10	NC	Non-Connection
11	NC	Non-Connection
12	NC	Non-Connection
13	VCD1	LED Cathode
14	VCD2	LED Cathode
15	VCD3	LED Cathode
16	VCD4	LED Cathode
17	VCD5	LED Cathode
18	VCD6	LED Cathode
19	NC	Non-Connection
20	NC	Non-Connection
21	NC	Non-Connection



Product Specification

AU OPTRONICS CORPORATION

22	V_{SS}	GND
23	V_{SS}	GND
24	V_{SS}	GND
25	V_{DD}	Power Supply, 2.5V
26	V_{DD}	Power Supply, 2.5V
27	V_{DD}	Power Supply, 2.5V
28	NC	Non-Connection
29	VAD	LED Anode
30	VAD	LED Anode

Note 1) Please refer to AC, DC timing specification of VESA DisplayPort Version 1.1a.

Note 2) Please connect GND pin to ground. Don't use it as no-connect nor connection with high impedance.

Note 3) Please connect NC to nothing. Don't connect it to ground nor to other signal input.



Product Specification

AU OPTRONICS CORPORATION

6.3 Interface Timing

6.3.1 Timing diagram

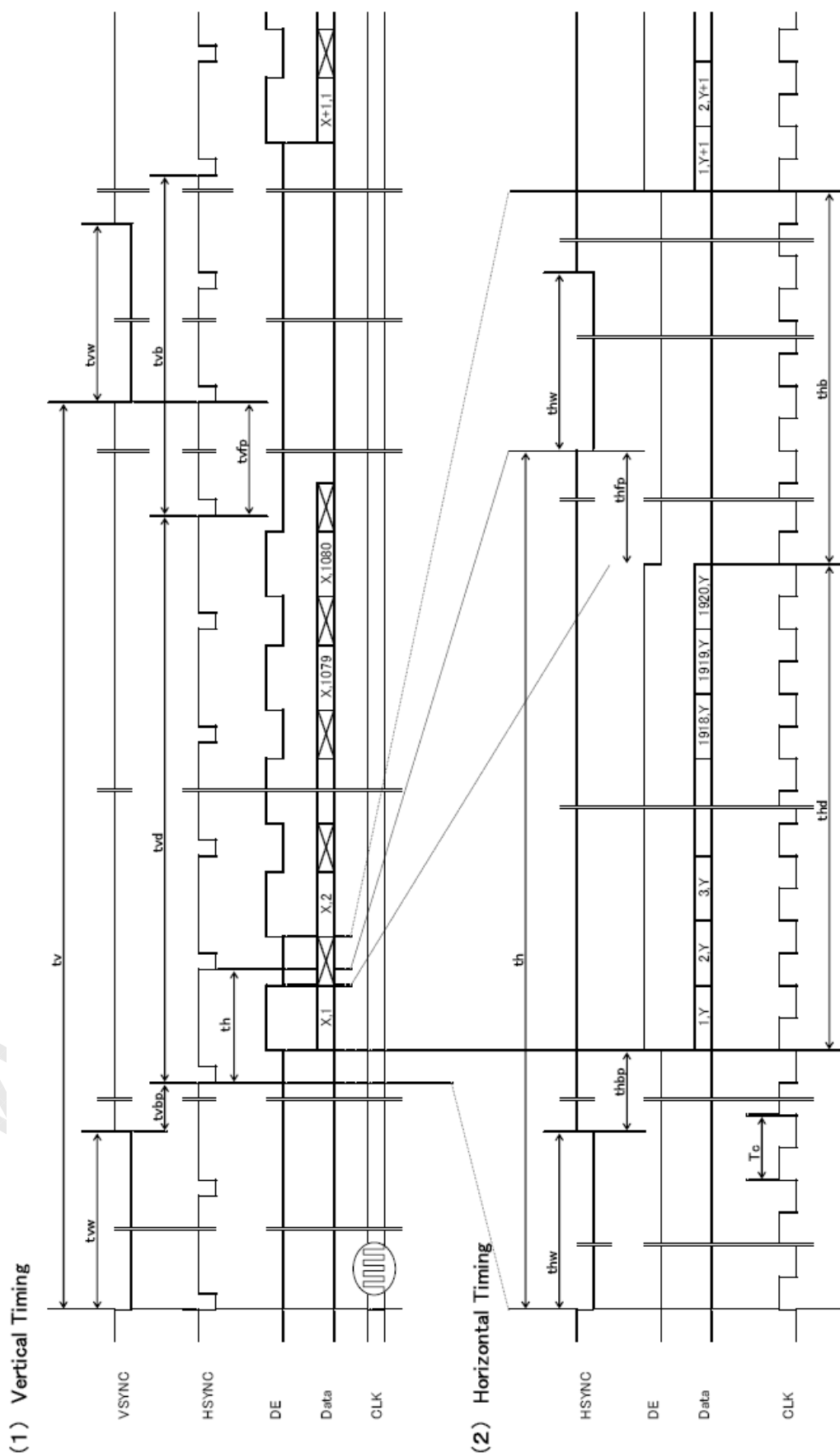



Product Specification

AU OPTRONICS CORPORATION

6.3.2 Timing Specifications

●60Hz

項目	記号	Min.	Typ.	Max.	単位
フレーム周期	tv	1092	1095	1100	th
		16.56	16.68	16.93	ms
垂直表示期間	tvd	1080	1080	1080	th
垂直ブランキング期間	tvb	12	15	20	th
1走査線時間	th	2450	2481	2502	tc
		15.16	15.24	15.39	μs
水平表示期間	thd	1920	1920	1920	tc
水平ブランキング期間	thb	530	561	582	tc
クロック周期	tc	159.2	162.84	165	MHz
		6.061	6.141	6.281	ns

●50Hz

項目	記号	Min.	Typ.	Max.	単位
フレーム周期	tv	1092	1095	1100	th
		19.66	20.00	20.87	ms
垂直表示期間	tvd	1080	1080	1080	th
垂直ブランキング期間	tvb	12	15	20	th
1走査線時間	th	2160	2169	2182	tc
		18.00	18.27	18.97	μs
水平表示期間	thd	1920	1920	1920	tc
水平ブランキング期間	thb	240	249	262	tc
クロック周期	tc	115	118.75	120	MHz
		8.333	8.421	8.696	ns

●40Hz

項目	記号	Min.	Typ.	Max.	単位
フレーム周期	tv	1092	1095	1100	th
		23.40	25.00	26.75	ms
垂直表示期間	tvd	1080	1080	1080	th
垂直ブランキング期間	tvb	12	15	20	th
1走査線時間	th	2250	2281	2310	tc
		21.43	22.83	24.32	μs
水平表示期間	thd	1920	1920	1920	tc
水平ブランキング期間	thb	330	361	390	tc
クロック周期	tc	95	99.91	105	MHz
		9.524	10.009	10.526	ns

項目	記号	Min.	Typ.	Max.	単位
垂直同期信号パルス幅	tvw	1			th
垂直フロントポーチ	tvfp	1			th
垂直バックポーチ	tvbp	2			th
水平同期信号パルス幅	thw	8			tc
水平フロントポーチ	thfp	8			tc
水平バックポーチ	thbp	8			tc
DEパルス幅	thd	1920	1920	1920	tc

※1 右の数式を満足する事。 $tvb = tvw + tvfp + tvbp$

※2 右の数式を満足する事。 $thb = thw + thfp + thbp$

注1) フレーム周期が遅くなりますと、フリッカ、点欠点など表示品位の低下を招く場合があります。

注2) Display port の AC, DC, タイミングについては VESA Display port Ver. 1.1a 参照ください。



Product Specification

AU OPTRONICS CORPORATION

6.4 Power ON/OFF Sequence

Power on/off sequence is as follows. Interface signals and LED on/off sequence are also shown in the chart. Signals from any system shall be Hi-Z state or low level when VDD is off

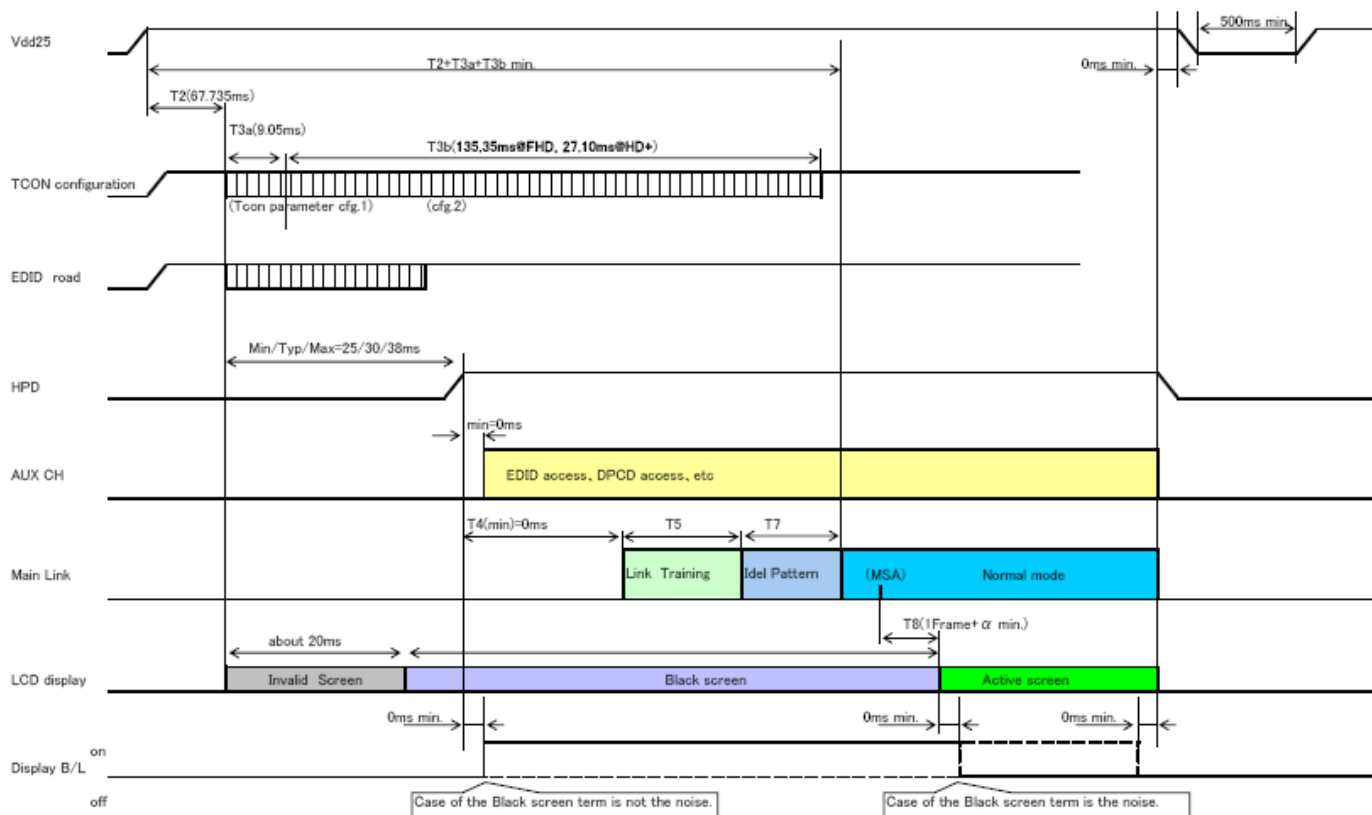



Product Specification

AU OPTRONICS CORPORATION

7. Panel Reliability Test

7.1 Reliability Test

This module is then tested in the following table.

However, this study will be conducted only one test item in the same module, multiple-item test module to perform the same

試験項目	試験条件		備考	結果
高温動作	5 0℃	計 4 8時間	動作 ³⁾	3p/3p OK
高温保存	6 5℃	計 4 8時間	非動作	3p/3p OK
高温高湿動作	4 5℃, 9 0%	計 4 8時間	動作 ³⁾	3p/3p OK
高温高湿保存	5 0℃, 9 0%	計 4 8時間	非動作	3p/3p OK
低温動作	0℃	計 4 8時間	動作 ³⁾	3p/3p OK
低温保存	- 3 0℃	計 4 8時間	非動作	3p/3p OK
温度急変	- 3 0℃ (2時間) ⇔ 6 5℃ (2時間)		1 2サイクル	非動作

注1) 試験はモジュールに結露の無い条件にて実施する。

注2) 試験後、常温常湿 (1 5℃~3 5℃, 4 5~6 5%(RH)) で2時間以上放置後、検査を実施する。

注3) 周囲温度 : T a 2 5 ± 5℃, 周囲湿度 : H a 6 5 ± 2 0%RH, 電源電圧 : V DD 2. 5 V; LED 入力順電流 : 1 9 mA

Product Specification

AU OPTRONICS CORPORATION



8. Mechanical Characteristics

8.1 LCM Outline Dimension

8.1.1 Standard Front View

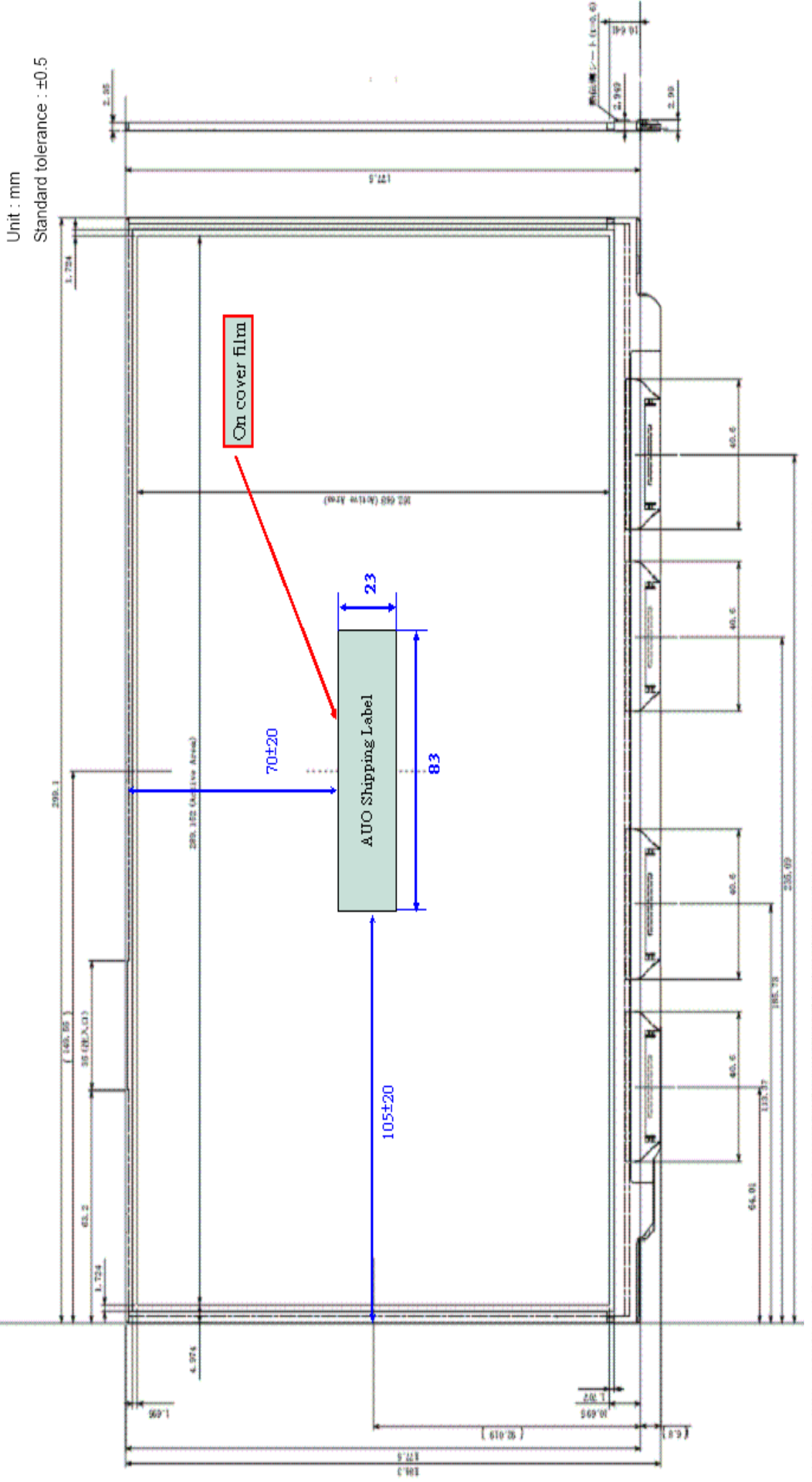



Product Specification

AU OPTRONICS CORPORATION

8.1.2 Standard Rear View

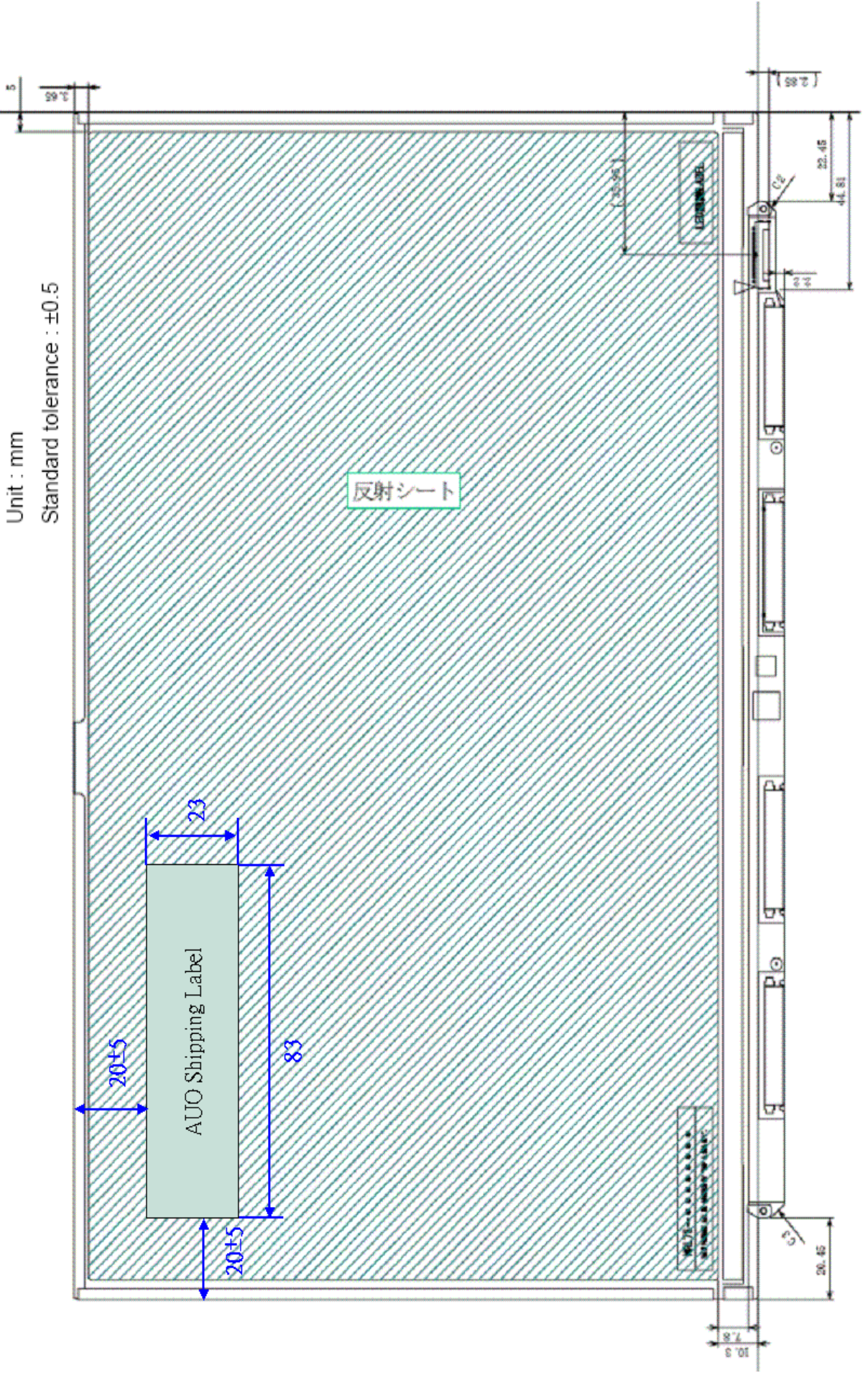



Product Specification

AU OPTRONICS CORPORATION

9. Shipping and Package

9.1 Shipping Label Format

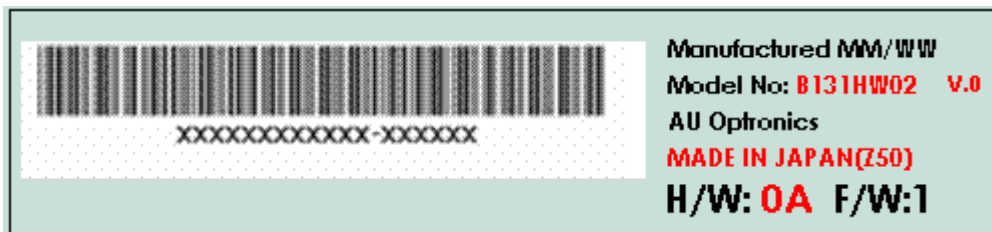

www.panelook.com



Product Specification

AU OPTRONICS CORPORATION

9.2 Carton Package

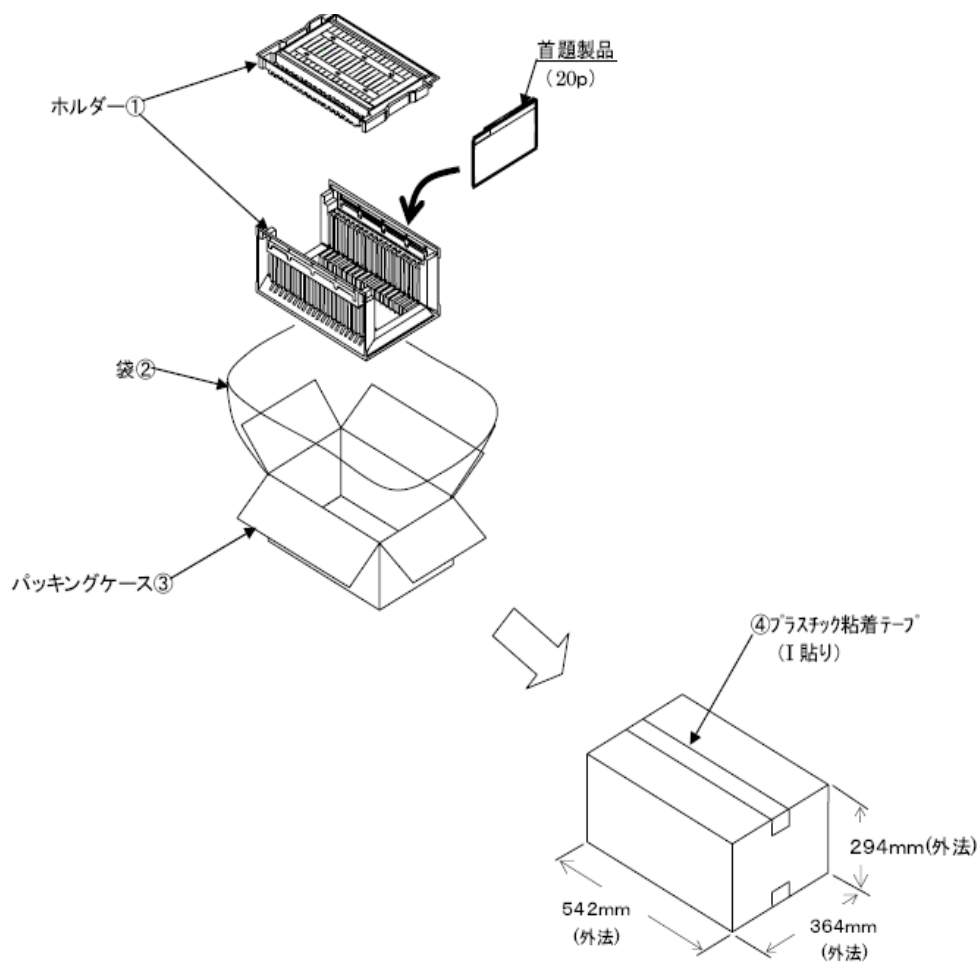



Product Specification

AU OPTRONICS CORPORATION

9.3 Shipping Package of Palletizing Sequence

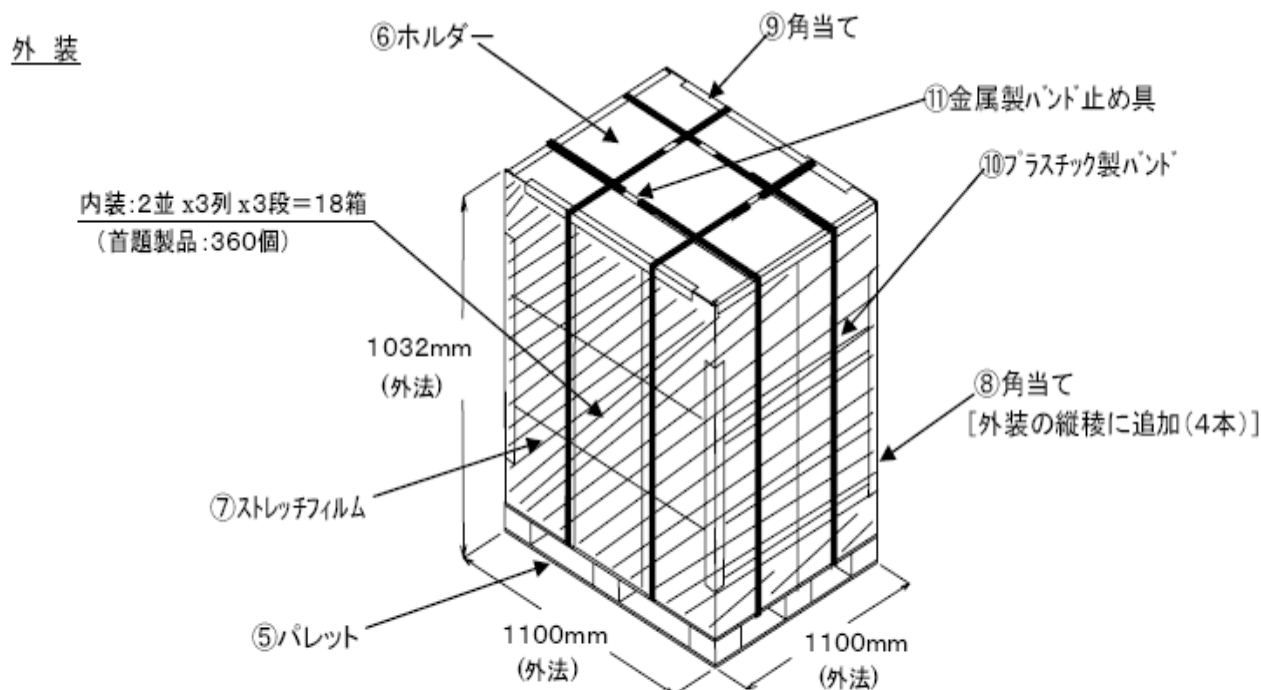

(注1)端数の場合は、下記の処置を行うこと。

- * 内装の積み段数を減らす。
- * 同じ段内で端数が生じた場合は、空の内装箱を詰め合わせる。

(注2)ストレッチフィルムの巻き方

- (1)巻き始めは粘着面を内側にしてフィルム端を図1の如く固定する。
- (2)巻き順は下側→上側→下側へ行く。
- (3)パレットの引っかかりは、フィルムを50mm以上でローピングする。
- (4)巻き数は下側2.5巻、中間、上側2巻とする。
- (5)巻きテンションはフィルム伸び率で約10%にする。
- (6)天面の引っかかり折り幅は200mm以上とする。
- (7)巻き終わりは、図2の如くフィルム端を固定する。
- (8)フィルムのつながぎはないこと。

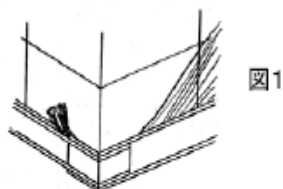



Product Specification

AU OPTRONICS CORPORATION

10. Appendix

10.1 EDID Description

Data No.	Data (Hex)	Data (Dec)	説明	実入力	2進数表示	10進数表示
0	00	0	固定入力(Header)			
1	FF	255				
2	FF	255				
3	FF	255				
4	FF	255				
5	FF	255				
6	FF	255				
7	00	0				
8	36	54	メーカーID	MS_	00110110	
9	7F	127	(ASCIIコードで入力)		01111111	
10	25	37	プロダクトID	0025		
11	00	0	(10, 11番地は逆転して使用される)			
12	01	1	シリアルNo. 未記入の場合は『01』入力	未記入		
13	01	1				
14	01	1				
15	01	1				
16	03	3	製造週(1-53週: 閏年は54週)	3週		3
17	14	20	製造年(製造年-1990)	2010年		20
18	01	1	EDID Version (Structure ①, ②)	1.4		1
19	04	4			①:18番地 ②:19番地	
20	A5	165	Video Input 情報		10100101	
21	1D	29	画面サイズ*(cm) (21番地:横 22番地:縦)	13.1inch		29
22	10	16		画面サイズ*	29cm/16cm	
23	78	120	階調: γ 値 (γ 値 \times 100-100)	$\gamma = 2.2$		120
24	02	2	サポート情報		00000010	
25	0F	15	色度: R,G,B,W 10進数を2進数(10桁)に変換。 その際、誤差は ± 0.0005 以下とする。 (例: 0.610 \rightarrow 1001110001) (0.6103516)	色度		00001111
26	15	21				00010101
27	9A	154			Rx=0.602	10011010
28	56	86			Ry=0.336	01010110
29	4B	75			Gx=0.296	01001011
30	8B	139			Gy=0.546	10001011
31	26	38			Bx=0.148	00100110
32	20	32			By=0.126	00100000
33	50	80			Wx=0.313	01010000
34	54	84			Wy=0.329	01010100
35	00	0	Establish Timing 受像可能な解像度には全てbitを立てる。 LCDは60Hzのみbitを立てるのが良い。	該当無し		00000000
36	00	0				00000000
37	00	0				00000000



Product Specification

AU OPTRONICS CORPORATION

Data No.	Data (Hex)	Data (Dec)	説明	実入力	2進数表示	10進数表示
38	D1	209	Standard Timing	1920		209
39	C0	192	・受像可能な代表的な全ての解像度を記入。	16.9 60Hz	11000000	
40	01	1	・2Byteのコードで1つの解像度を表示。			
41	01	1	・計8種類の解像度を記述出来る。			
42	01	1	・E-Timing(35-37番地)と重複しない事。			
43	01	1	・E-TimingとS-Timingのどちらかに			
44	01	1	最大解像度を記述する。			
45	01	1	・未使用部分には 01 01 を入れる。			
46	01	1				
47	01	1	#1:(水平解像度/8)-31 → 16進数			
48	01	1	#2:7-6Bit…アスペクト比			
49	01	1	16:10 → 0,0			
50	01	1	4:3 → 0,1			
51	01	1	5:4 → 1,0			
52	01	1	16:9 → 1,1			
53	01	1	5-0Bit…リフレッシュレート - 60			
54	9C	156	推奨タイミング(24番地のフラグを立てておく)			
55	3F	63	54,55番地:ピクセルクロック/10000	162.84MHz		16284
56	80	128	56番地:水平表示期間(pixels)/下位8bit(全12bit)	1920Pixels	10000000	1920
57	31	49	57番地:水平フランクング(pixels)/下位8bit(全12bit)	561Pixels	00110001	561
58	72	114	58番地:H-A上位4bit + H-B上位4bit		01110010	
59	38	56	59番地:垂直表示期間(lines)/下位8bit(全12bit)	1080Lines	00111000	1080
60	0F	15	60番地:垂直フランクング(lines)/下位8bit(全12bit)	15Lines	00001111	15
61	40	64	61番地:V-A上位4bit + V-B上位4bit		01000000	
62	20	32	62番地:H-Sync. Offset(70ピクセル)/下位8bit(全10bit)	32Pixels	00100000	32
63	20	32	63番地:H-Sync.(ハルス幅)/下位8bit(全10bit)	32Pixels	00100000	32
64	33	51	64番地:V-70ピクセル下位4bit + V-Sync.下位4bit(全6bit)	3/3Lines	00110011	
65	00	0	65番地:コメント参照		00000000	
66	23	35	66番地:画面サイズ横(mm)/下位8bit(全12bit)	291mm	00100011	291
67	A4	164	66番地:画面サイズ縦(mm)/下位8bit(全12bit)	164mm	10100100	164
68	10	16	68番地:画面サイズ上位4bit + 画面サイズ縦上位4bit		00010000	
69	00	0	69番地:H-Border(全8bit)	0Pixels	00000000	0
70	00	0	70番地:V-Border(全8bit)	0Lines	00000000	0
71	18	24	71番地:フラグ(E-EDID Standard Page 18 of 32参照)		00011000	
72	07	7	40Hzタイミング			
73	27	39	72,73番地:ピクセルクロック/10000	99.91MHz		9991
74	80	128	74番地:水平表示期間(pixels)/下位8bit(全12bit)	1920Pixels	10000000	1920
75	69	105	75番地:水平フランクング(pixels)/下位8bit(全12bit)	361Pixels	01101001	361
76	71	113	76番地:H-A上位4bit + H-B上位4bit		01110001	
77	38	56	77番地:垂直表示期間(lines)/下位8bit(全12bit)	1080Lines	00111000	1080
78	0F	15	78番地:垂直フランクング(lines)/下位8bit(全12bit)	15Lines	00001111	15
79	40	64	79番地:V-A上位4bit + V-B上位4bit		01000000	
80	20	32	80番地:H-Sync. Offset(70ピクセル)/下位8bit(全10bit)	32Pixels	00100000	32
81	20	32	81番地:H-Sync.(ハルス幅)/下位8bit(全10bit)	32Pixels	00100000	32
82	33	51	82番地:V-70ピクセル下位4bit + V-Sync.下位4bit(全6bit)	3/3Lines	00110011	
83	00	0	83番地:コメント参照		00000000	
84	23	35	84番地:画面サイズ横(mm)/下位8bit(全12bit)	291mm	00100011	291
85	A4	164	85番地:画面サイズ縦(mm)/下位8bit(全12bit)	164mm	10100100	164
86	10	16	86番地:画面サイズ上位4bit + 画面サイズ縦上位4bit		00010000	
87	00	0	87番地:H-Border(全8bit)	0Pixels	00000000	0
88	00	0	88番地:V-Border(全8bit)	0Lines	00000000	0
89	18	24	89番地:フラグ(E-EDID Standard Page 18 of 32参照)		00011000	



Product Specification

AU OPTRONICS CORPORATION

Data No.	Data (Hex)	Data (Dec)	説明	実入力	2進数表示	10進数表示
90	00	0	モデル名 (識別 FC) Header:00 00 00 FC 00 モデル名:ASCIIコードにて記述 Terminator:0A Blank:20 得意要求:Sony LCD ASCIIコード			
91	00	0				
92	00	0				
93	FC	252				
94	00	0				
95	53	83				
96	6F	111				
97	6E	110				
98	79	121				
99	20	32				
100	4C	76				
101	43	67				
102	44	68				
103	0A	10				
104	20	32				
105	20	32				
106	20	32				
107	20	32				
108	00	0	Monitor Range (識別 FD) Header:00 00 00 FD 00 113番地:最小フレーム周波数(Hz) 整数入力 114番地:最大フレーム周波数(Hz) 整数入力 115番地:最小水平周波数(kHz) 整数入力 116番地:最大水平周波数(kHz) 整数入力 117番地:最大クロック周波数(MHz)/10 118-125番地: Terminator...00 0A 残り...20 20 20 20 20 20 Terminator:0A Blank:20			
109	00	0				
110	00	0				
111	FD	253				
112	00	0				
113	27	39				
114	3D	61				
115	2B	43				
116	42	66				
117	11	17				
118	00	0				
119	0A	10				
120	20	32				
121	20	32				
122	20	32				
123	20	32				
124	20	32				
125	20	32				
126	00	0	Extension Flag (Extensionが無い場合は"00"と記入)			
127	2A	42	Check-Sum (0-127番地を合計し下2桁が00になる値)			