



Product Specification

AU OPTRONICS CORPORATION

- () Preliminary Specifications
- (V) Final Specifications

Module	14.0" FHD 16:9 Color TFT-LCD with LED Backlight design
Model Name	B140HAN01.3 (H/W:1A)
Note ()	<i>LED Backlight with driving circuit design</i>

Customer	Date
Checked & Approved by	Date
Note: This Specification is subject to change without notice.	

Approved by	Date
<u>Jonken Fan</u>	<u>09/19/2014</u>
Prepared by	Date
<u>Evonne Chao</u>	<u>09/19/2014</u>
NBBU Marketing Division AU Optronics corporation	



Contents

1. Handling Precautions	4
2. General Description	5
2.1 General Specification	5
2.2 Optical Characteristics	6
3. Functional Block Diagram	11
4. Absolute Maximum Ratings	12
4.1 Absolute Ratings of TFT LCD Module.....	12
4.2 Absolute Ratings of Environment	12
5. Electrical Characteristics	13
5.1 TFT LCD Module.....	13
5.2 Backlight Unit	16
6. Signal Interface Characteristic	17
6.1 Pixel Format Image	17
6.2 Integration Interface Requirement.....	18
6.3 Interface Timing	21
6.4 Power ON/OFF Sequence	22
7. Panel Reliability Test	25
7.1 Vibration Test	25
7.2 Shock Test	25
7.3 Reliability Test.....	25
8. Mechanical Characteristics	26
8.1 LCM Outline Dimension.....	26
9. Shipping and Package	28
9.1 Shipping Label Format	28
9.2 Carton Package.....	29
9.3 Shipping Package of Palletizing Sequence.....	29
10. Appendix: EDID Description	30



Product Specification

AU OPTRONICS CORPORATION

Record of Revision

Version and Date	Page	Old description	New Description	Remark
0.1 2013/8/23	All	First Edition for Customer		
0.2 2014/01/29	28 30-33		Add label and modify EDID	
0.3 2014/02/06			Add RGB spec	
0.4 2014/03/03	5	Power Consumption=4.8W	Power Consumption=5.4W	
0.5 2014/03/29	28 30	X11	X20	
0.6 2014/05/05	28 30	X20	X21	
1.1 2014/09/19	29	9. Shipping and Package Version : A00	9. Shipping and Package Version : A01	
	30 31 32	10. Appendix: EDID Description Version : A00	10. Appendix: EDID Description Version : A01	

1. Handling Precautions

- 1) Since front polarizer is easily damaged, pay attention not to scratch it.
- 2) Be sure to turn off power supply when inserting or disconnecting from input connector.
- 3) Wipe off water drop immediately. Long contact with water may cause discoloration or spots.
- 4) When the panel surface is soiled, wipe it with absorbent cotton or other soft cloth.
- 5) Since the panel is made of glass, it may break or crack if dropped or bumped on hard surface.
- 6) Since CMOS LSI is used in this module, take care of static electricity and insure human earth when handling.
- 7) Do not open nor modify the Module Assembly.
- 8) Do not press the reflector sheet at the back of the module to any directions.
- 9) At the insertion or removal of the Signal Interface Connector, be sure not to rotate nor tilt the Interface Connector of the TFT Module.
- 11) After installation of the TFT Module into an enclosure (Notebook PC Bezel, for example), do not twist nor bend the TFT Module even momentary. At designing the enclosure, it should be taken into consideration that no bending/twisting forces are applied to the TFT Module from outside. Otherwise the TFT Module may be damaged.
- 12) Small amount of materials having no flammability grade is used in the LCD module. The LCD module should be supplied by power complied with requirements of Limited Power Source (IEC60950 or UL1950), or be applied exemption.
- 13) Disconnecting power supply before handling LCD modules, it can prevent electric shock, DO NOT TOUCH the electrode parts, cables, connectors and LED circuit part of TFT module that a LED light bar build in as a light source of back light unit. It can prevent electrostatic breakdown.



Product Specification

AU OPTRONICS CORPORATION

2. General Description

B140HAN01.3 is a Color Active Matrix Liquid Crystal Display composed of a TFT LCD panel, a driver circuit, and LED backlight system. The screen format is intended to support the 16:9 FHD, 1920(H)x1080(V) screen and 262k colors (RGB 6-bits data driver) with LED backlight driving circuit. All input signals are eDP(Embedded DisplayPort) interface compatible.

B140HAN01.3 is designed for a display unit of notebook style personal computer and industrial machine.

2.1 General Specification

The following items are characteristics summary on the table at 25 °C condition:

Items	Unit	Specifications			
Screen Diagonal	[mm]	354.69			
Active Area	[mm]	309.14 X 173.89			
Pixels H x V		1920x3(RGB) x 1080			
Pixel Pitch	[mm]	0.161X0.161			
Pixel Format		R.G.B. Vertical Stripe			
Display Mode		Normally Black			
White Luminance (ILED=22mA) (Note: ILED is LED current)	[cd/m ²]	300 typ. (5 points average) 255 min. (5 points average)			
Luminance Uniformity		1.25 max. (5 points)			
Contrast Ratio		700 typ			
Response Time	[ms]	25			
Nominal Input Voltage VDD	[Volt]	+3.3 typ.			
Power Consumption	[Watt]	5.4 max (include logic and Blu power) (Note:1)			
Weight	[Grams]	285 max.			
Physical Size Include bracket	[mm]		Min.	Typ.	Max.
		Length	319.9	320.4	320.9
		Width	204.6	205.1	205.6
		Thickness	-	-	3.0
Electrical Interface		2 Lane eDP1.3			
Glass Thickness	[mm]	0.5			
Surface Treatment		Anti - Glare, Hardness 3H			
Support Color		6-bit + FRC			
Temperature Range					
	Operating	[°C]	0 to +50		
Storage (Non-Operating)	[°C]	-20 to +60			
RoHS Compliance		RoHS Compliance			

Note1. AUO power consumption at typical mosaic Pattern.

2.2 Optical Characteristics

The optical characteristics are measured under stable conditions at 25°C (Room Temperature) :

Item	Symbol	Conditions	Min.	Typ.	Max.	Unit	Note		
White Luminance I _{LED} =22mA		5 points average	255	300	-	cd/m ²	1, 4, 5.		
Viewing Angle	θ_R	Horizontal (Right) CR = 10 (Left)	85	89	-	degree	4, 9		
	θ_L		85	89	-				
	ϕ_H	Vertical (Upper) CR = 10 (Lower)	85	89	-	degree			
	ϕ_L		85	89	-				
Luminance Uniformity	δ_{5P}	5 Points	-	-	1.25		1, 3, 4		
Luminance Uniformity	δ_{13P}	13 Points	-	-	1.5		2, 3, 4		
Contrast Ratio	CR		-	700	-		4, 6		
Cross talk	%				4		4, 7		
Response Time	T _{RT}	Rising + Falling	-	25	35	msec	4, 8		
Color / Chromaticity Coordinates	Red	Rx	0.613	0.643	0.673	CIE 1931	4		
		Ry	0.306	0.336	0.366				
	Green	Gx	0.283	0.313	0.343				
		Gy	0.595	0.625	0.655				
	Blue	Bx	0.121	0.151	0.181				
		By	0.023	0.053	0.083				
	White	Wx	0.283	0.313	0.343				
		Wy	0.299	0.329	0.359				
	NTSC	%		-	72			-	

Note 1: 5 points position (Ref: Active area)

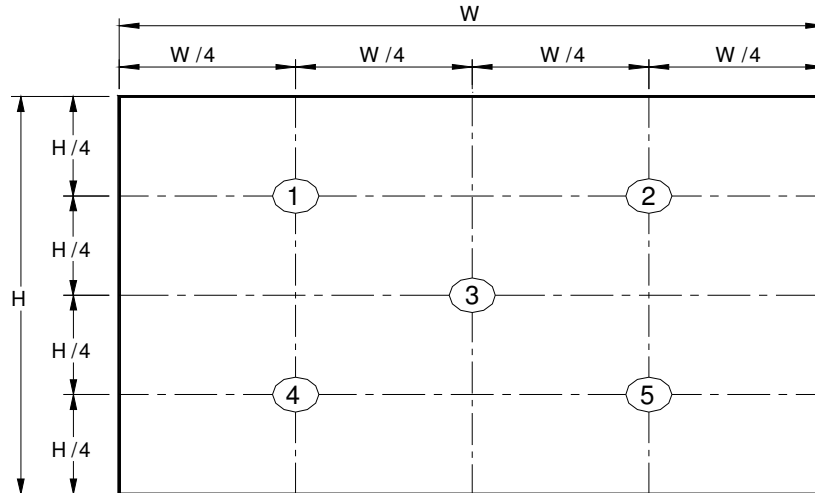

Note 2: 13 points position (Ref: Active area)

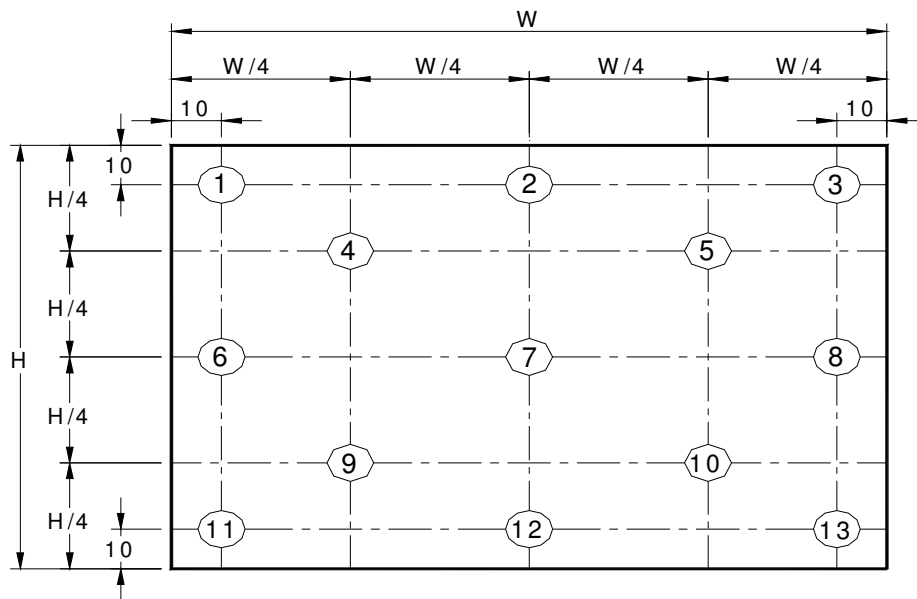

Note 3: The luminance uniformity of 5 or 13 points is defined by dividing the maximum luminance values by the minimum test point luminance

$$\delta_{W5} = \frac{\text{Maximum Brightness of five points}}{\text{Minimum Brightness of five points}}$$

$$\delta_{W13} = \frac{\text{Maximum Brightness of thirteen points}}{\text{Minimum Brightness of thirteen points}}$$

Note 4: Measurement method

The LCD module should be stabilized at given temperature for 30 minutes to avoid abrupt temperature change during measuring. In order to stabilize the luminance, the measurement should be executed after lighting

Backlight for 30 minutes in a stable, windless and dark room, and it should be measured in the center of screen.

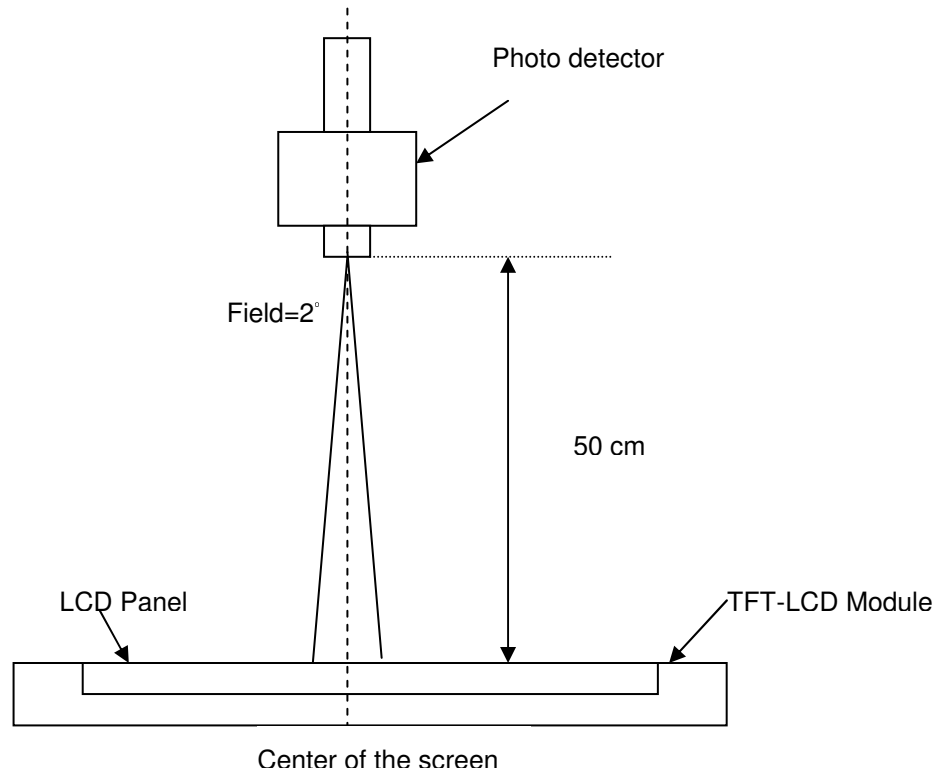

Note 5 : Definition of Average Luminance of White (Y_L):

Measure the luminance of gray level 63 at 5 points · $Y_L = [L(1) + L(2) + L(3) + L(4) + L(5)] / 5$

$L(x)$ is corresponding to the luminance of the point X at Figure in Note (1).

Note 6 : Definition of contrast ratio:

Contrast ratio is calculated with the following formula.

$$\text{Contrast ratio (CR)} = \frac{\text{Brightness on the "White" state}}{\text{Brightness on the "Black" state}}$$

Note 7 : Definition of Cross Talk (CT)

$$CT = |Y_B - Y_A| / Y_A \times 100 (\%)$$

Where

Y_A = Luminance of measured location without gray level 0 pattern (cd/m^2)

Y_B = Luminance of measured location with gray level 0 pattern (cd/m^2)

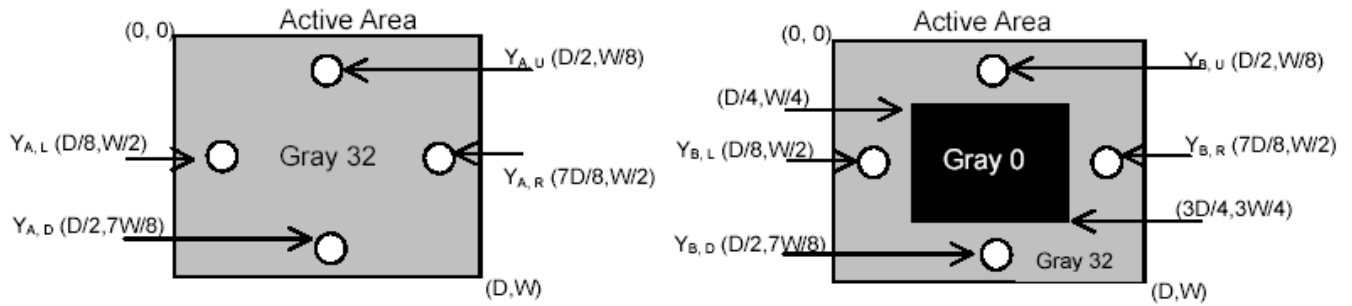

Note 8: Definition of response time:

The output signals of BM-7 or equivalent are measured when the input signals are changed from “Black” to “White” (falling time) and from “White” to “Black” (rising time), respectively. The response time interval between the 10% and 90% of amplitudes. Refer to figure as below.

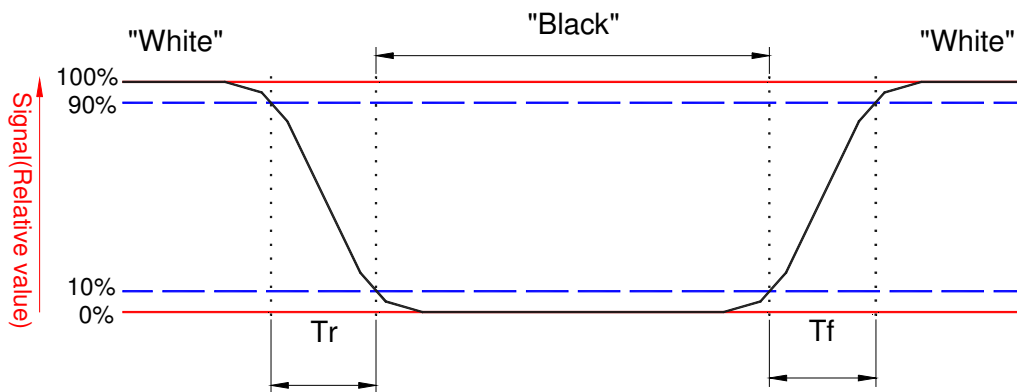

Note 9. Definition of viewing angle

Viewing angle is the measurement of contrast ratio ≥ 10 , at the screen center, over a 180° horizontal and 180° vertical range (off-normal viewing angles). The 180° viewing angle range is broken down as follows; 90° (θ) horizontal left and right and 90° (Φ) vertical, high (up) and low (down). The measurement direction is typically perpendicular to the display surface with the screen rotated about its center to develop the desired measurement viewing angle.

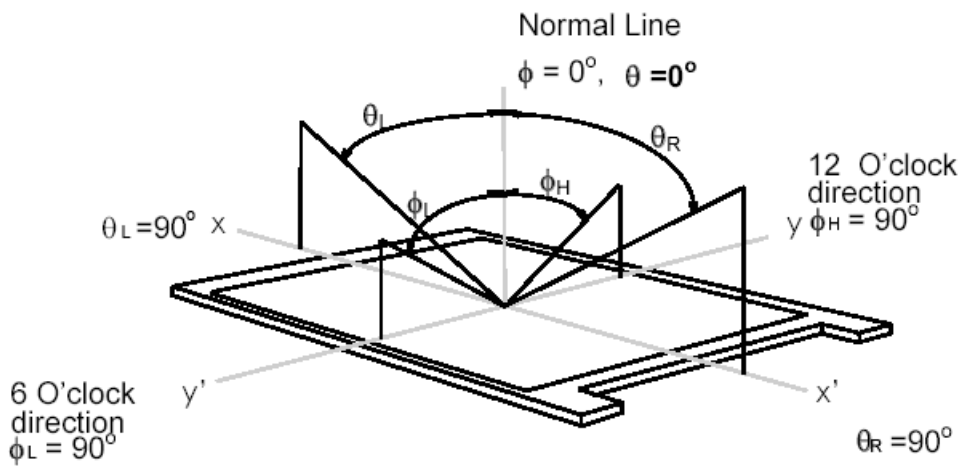

3. Functional Block Diagram

The following diagram shows the functional block of the 14.0 inches wide Color TFT/LCD 30 Pin

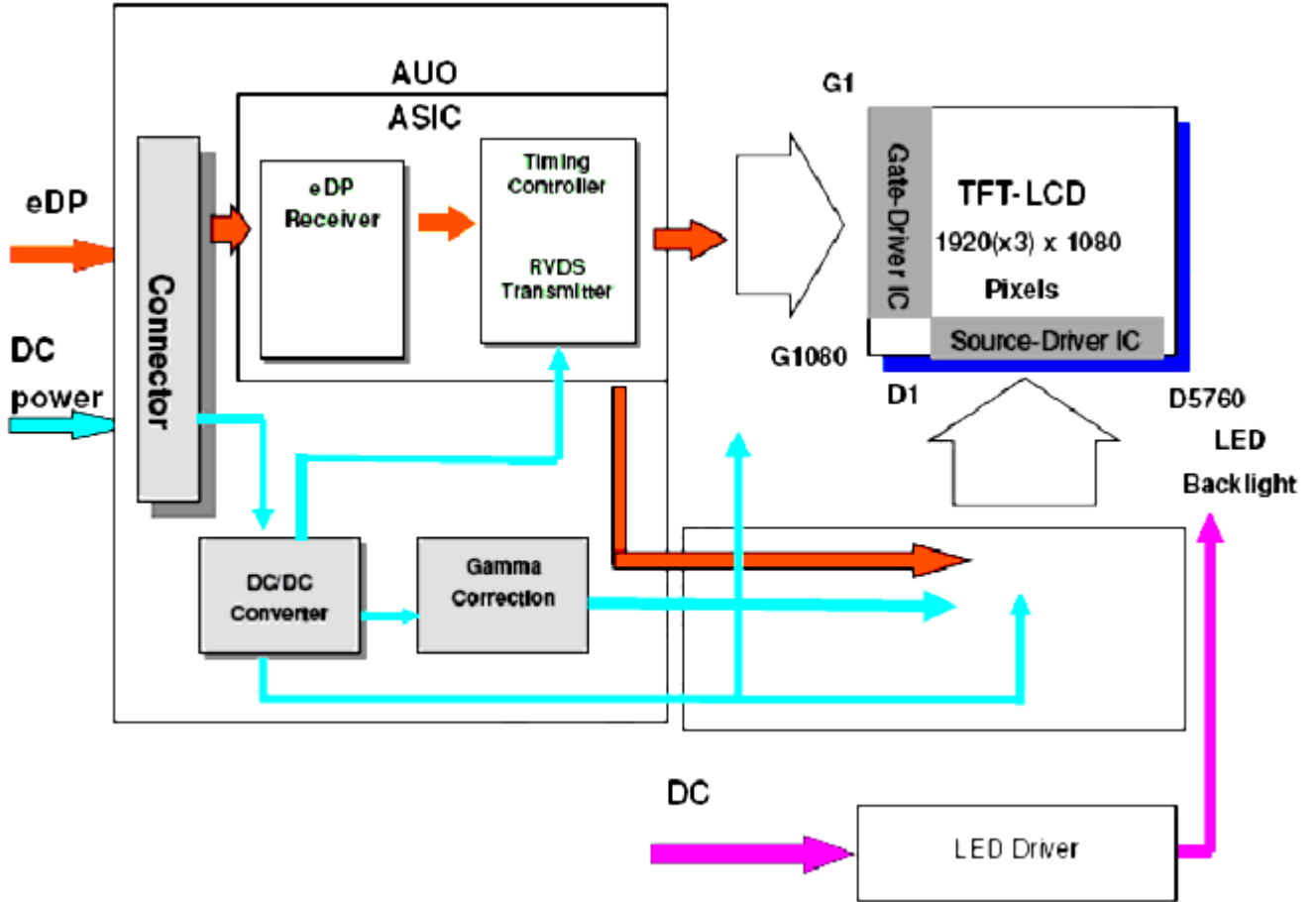

4. Absolute Maximum Ratings

An absolute maximum rating of the module is as following:

4.1 Absolute Ratings of TFT LCD Module

Item	Symbol	Min	Max	Unit	Conditions
Logic/LCD Drive Voltage	Vin	-0.3	+4.0	[Volt]	Note 1,2

4.2 Absolute Ratings of Environment

Item	Symbol	Min	Max	Unit	Conditions
Operating Temperature	TOP	0	+50	[°C]	Note 4
Operation Humidity	HOP	5	95	[%RH]	Note 4
Storage Temperature	TST	-20	+60	[°C]	Note 4
Storage Humidity	HST	5	95	[%RH]	Note 4

Note 1: At Ta (25°C)

Note 2: Permanent damage to the device may occur if exceed maximum values

Note 3: LED specification refer to section 5.2

Note 4: For quality performance, please refer to AUO IIS (Incoming Inspection Standard).

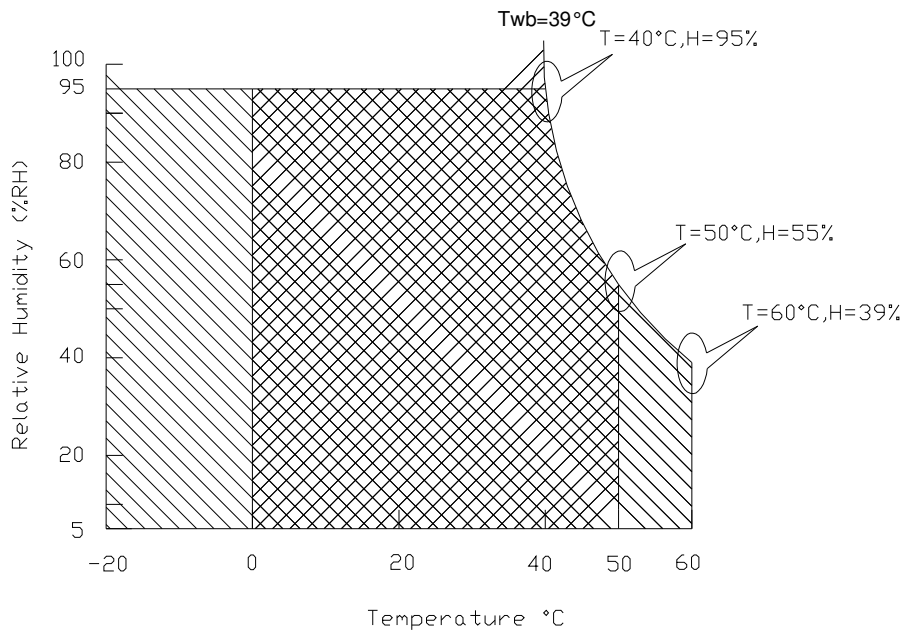

Operating Range 

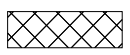
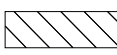
Storage Range  + 

5. Electrical Characteristics

5.1 TFT LCD Module

5.1.1 Power Specification

Input power specifications are as follows;

The power specification are measured under 25°C and frame frequency under 60Hz

Symble	Parameter	Min	Typ	Max	Units	Note
VDD	Logic/LCD Drive Voltage	3.0	3.3	3.6	[Volt]	
PDD	VDD Power	-	-	1.4	[Watt]	Note 1
IDD	IDD Current	-	-	394	[mA]	Note 1
IRush	Inrush Current	-	-	1500	[mA]	Note 2
VDDrp	Allowable Logic/LCD Drive Ripple Voltage	-	-	100	[mV] p-p	

Note 1 : Maximum Measurement Condition : Black Pattern at 3.3V driving voltage. ($P_{max}=V_{3.3} \times I_{black}$)

Typical Measurement Condition : Mosaic Pattern

Note 2 : Measure Condition

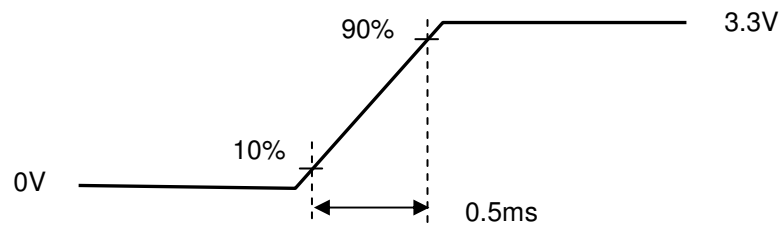
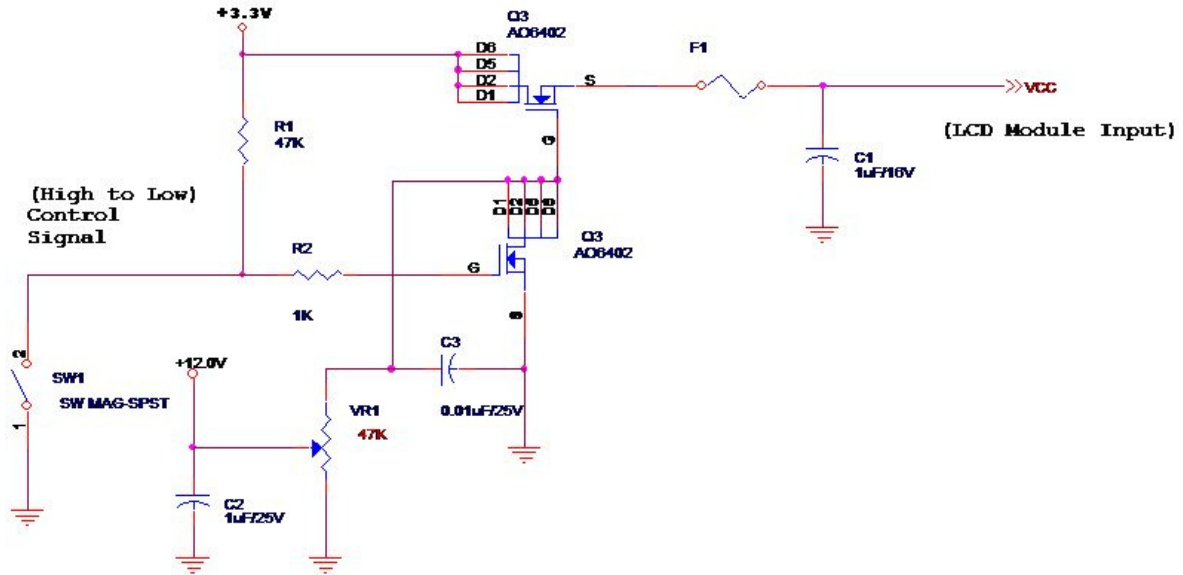

Vin rising time

5.1.2 Signal Electrical Characteristics

Input signals shall be low or High-impedance state when VDD is off.

Signal electrical characteristics are as follows;

Display Port main link signal:

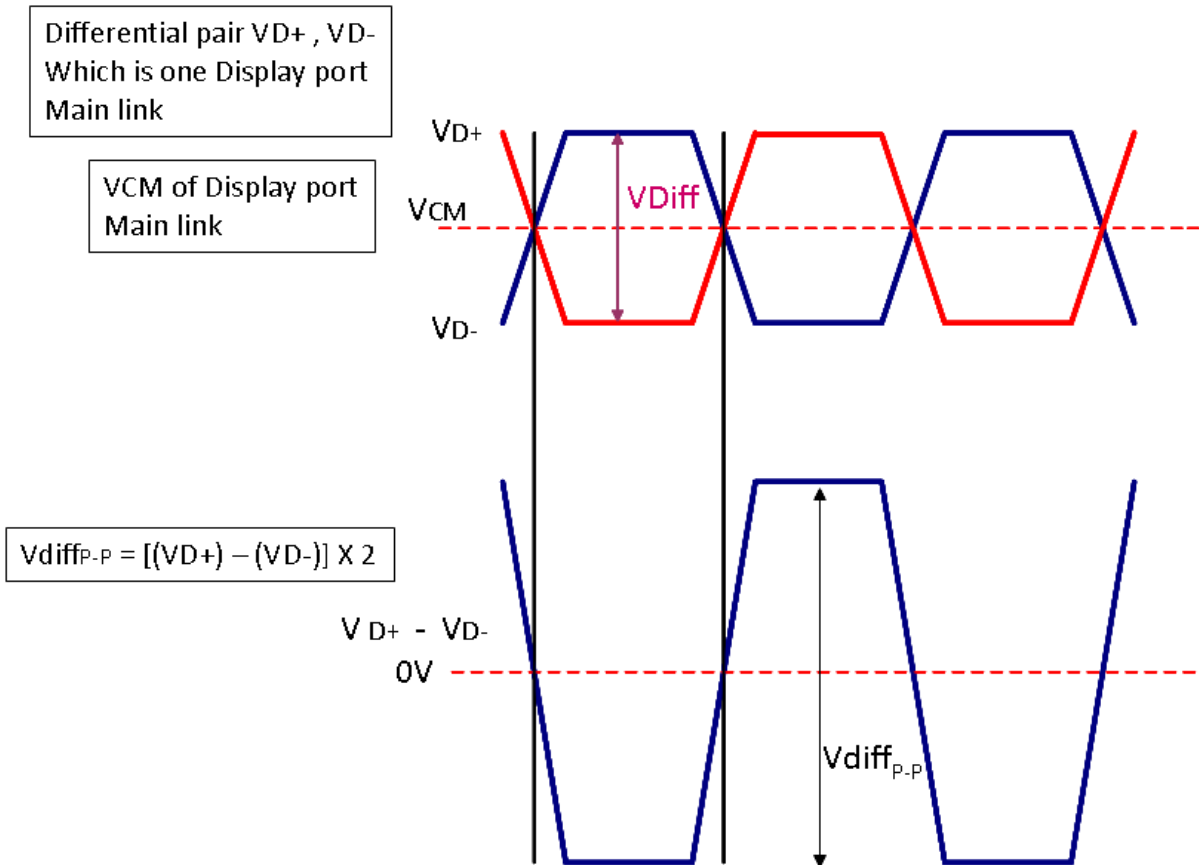

Display port main link					
		Min	Typ	Max	unit
VCM	RX input DC Common Mode Voltage		0		V
VDiff _{P-P}	Peak-to-peak Voltage at a receiving Device	100		1320	mV

Follow as VESA display port standard V1.1a

Display Port AUX_CH signal:

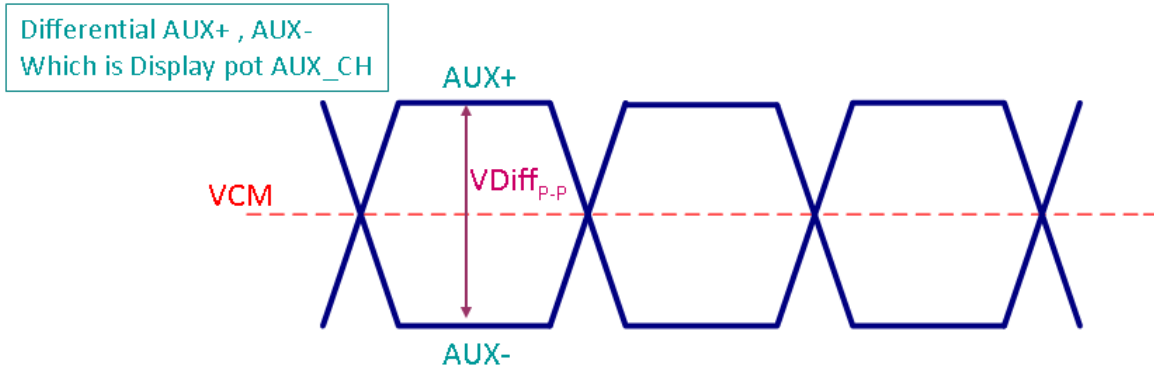

Display port AUX_CH					
		Min	Typ	Max	unit
VCM	AUX DC Common Mode Voltage		0		V
VDiff _{p-p}	AUX Peak-to-peak Voltage at a receiving Device	0.4	0.6	0.8	V

Fallow as VESA display port standard V1.1a.

Display Port VHPD signal:

Display port VHPD					
		Min	Typ	Max	unit
VHPD	HPD Voltage	2		2.5	V

Fallow as VESA display port standard V1.1a.



Product Specification

AU OPTRONICS CORPORATION

5.2 Backlight Unit

5.2.1 LED characteristics

Parameter	Symbol	Min	Typ	Max	Units	Condition
Backlight Power Consumption	PLED	-	-	3.4	[Watt]	(Ta=25°C), Note 1 Vin =12V
LED Life-Time	N/A	15,000	-	-	Hour	(Ta=25°C), Note 2 If=22 mA

Note 1: Calculator value for reference $P_{LED} = VF$ (Normal Distribution) * I_F (Normal Distribution) / Efficiency

Note 2: The LED life-time define as the estimated time to 50% degradation of initial luminous.

5.2.2 Backlight input signal characteristics

Parameter	Symbol	Min	Typ	Max	Units	Remark
LED Power Supply	VLED	5.0 Note2	12.0	21.0	[Volt]	Define as Connector Interface (Ta=25°C)
LED Enable Input High Level	VLED_EN	2.5	-	3.3	[Volt]	
LED Enable Input Low Level		-	-	0.5	[Volt]	
PWM Logic Input High Level	VPWM_EN	2.5	-	3.3	[Volt]	
PWM Logic Input Low Level		-	-	0.5	[Volt]	
PWM Input Frequency	FPWM	200	1K	10K	Hz	
PWM Duty Ratio	Duty	5	--	100	%	

Note 1 : Recommend system pull up/down resistor no bigger than 10kohm

Note 2 : measured in panel VLED at PWM duty ratio 100%

6. Signal Interface Characteristic

6.1 Pixel Format Image

Following figure shows the relationship of the input signals and LCD pixel format.

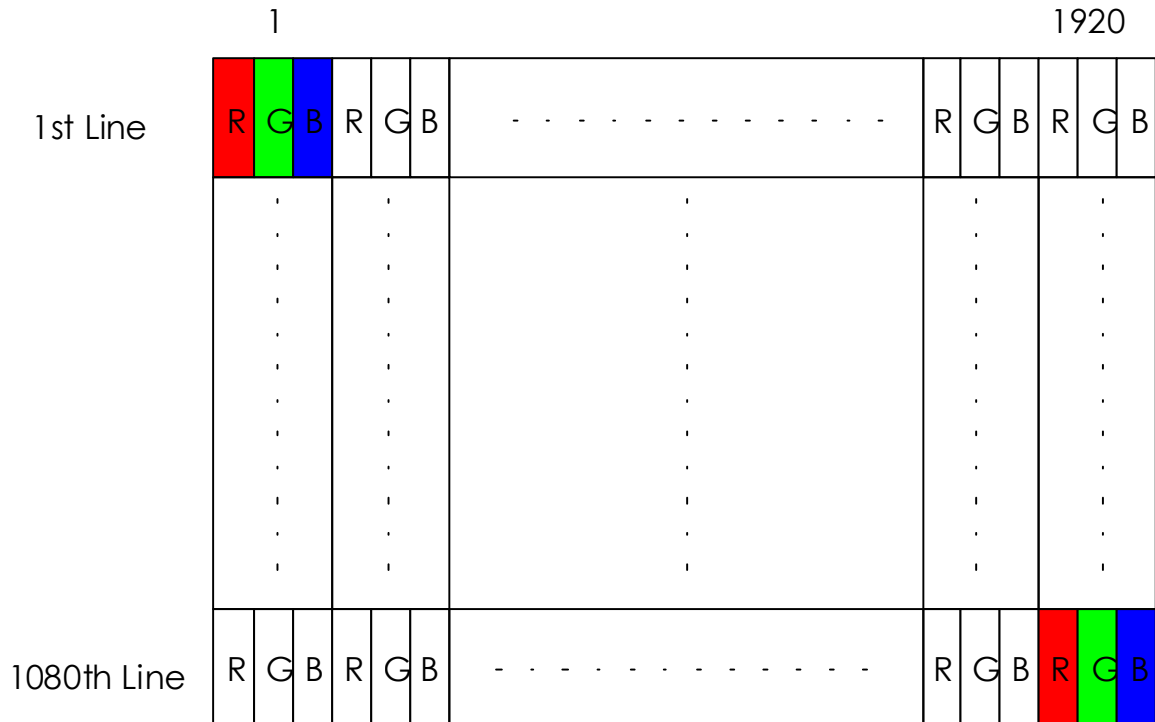



6.2 Integration Interface Requirement

6.2.1 Connector Description

Physical interface is described as for the connector on module.

These connectors are capable of accommodating the following signals and will be following components.

Connector Name / Designation	For Signal Connector
Manufacturer	IPEX or compatible
Type / Part Number	IPEX 20455-030E-12 or compatible
Mating Housing/Part Number	IPEX 20453-030T-11 or compatible

6.2.2 Pin Assignment (2 Lane)

eDP lane is a differential signal technology for LCD interface and high speed data transfer device.

PIN NO	Symbol	Function
1	DBC_EN	NC
2	H_GND	High Speed Ground
3	Lane1_N	Complement Signal Link Lane 1
4	Lane1_P	True Signal Link Lane 1
5	H_GND	High Speed Ground
6	Lane0_N	Complement Signal Link Lane 0
7	Lane0_P	True Signal Link Lane 0
8	H_GND	High Speed Ground
9	AUX_CH_P	True Signal Auxiliary Ch.
10	AUX_CH_N	Complement Signal Auxiliary Ch.
11	H_GND	High Speed Ground
12	LCD_VCC	LCD logic and driver power
13	LCD_VCC	LCD logic and driver power
14	LCD_Self_Test	LCD Panel Self Test Enable
15	LCD_GND	LCD logic and driver ground
16	LCD_GND	LCD logic and driver ground
17	HPD	Hot Plug Detection signal pin
18	BL_GND	Backlight_ground
19	BL_GND	Backlight_ground
20	BL_GND	Backlight_ground
21	BL_GND	Backlight_ground
22	BL_Enable	Backlight On / Off
23	BL_PWM_DIM	System PWM signal Input
24	NC	Reverse for AUO TEST only
25	NC	Reverse for AUO TEST only
26	BL_PWR	Backlight power (5V~21V)
27	BL_PWR	Backlight power (5V~21V)
28	BL_PWR	Backlight power (5V~21V)
29	BL_PWR	Backlight power (5V~21V)
30	COLOR_EN	NC

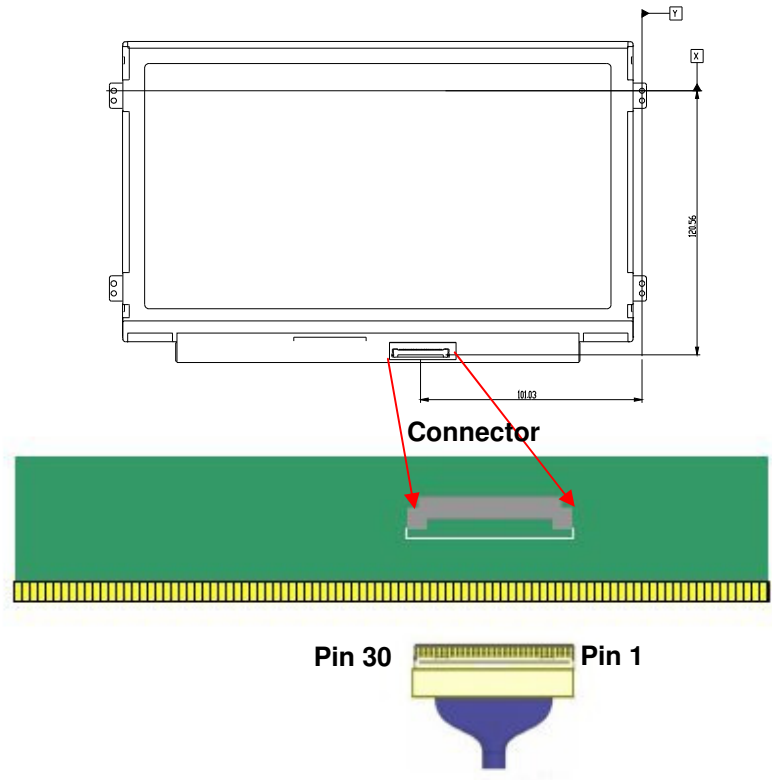

Note1: Start from right side.

Note2: Input signals shall be low or High-impedance state when VDD is off.
Internal circuit of **eDP inputs** are as following.

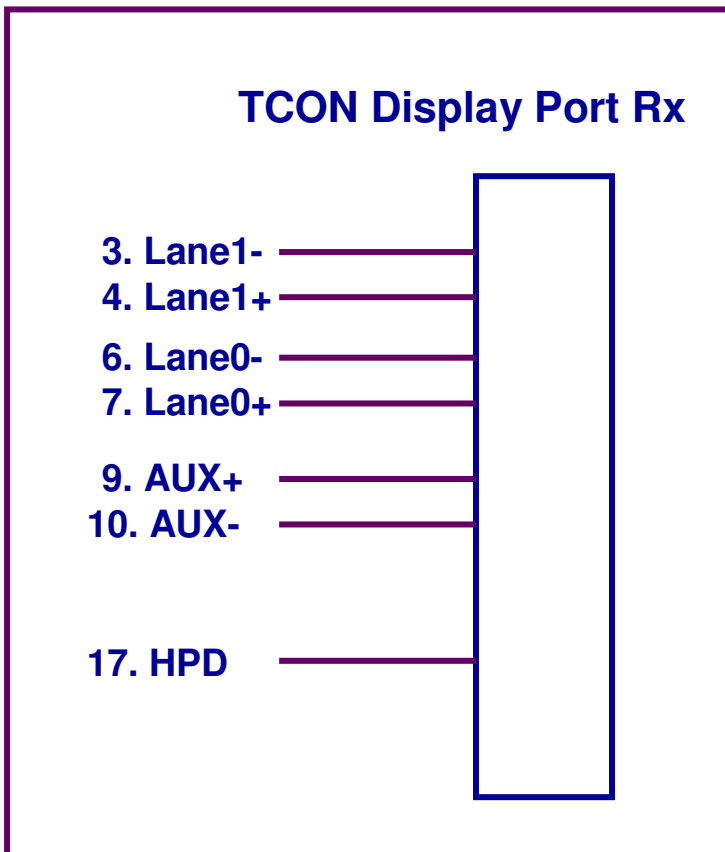

6.3 Interface Timing

6.3.1 Timing Characteristics

Basically, interface timings should match the 1920x1080 /60Hz manufacturing guide line timing. (If not 1920 resolution, pls help to delet this item)

Parameter		Symbol	Min.	Typ.	Max.	Unit
Frame Rate		-	-	60	-	Hz
Clock frequency		$1/T_{\text{Clock}}$		141		MHz
Vertical Section	Period	T_V	1090	1116	3080	T_{Line}
	Active	T_{VD}	1080			
	Blanking	T_{VB}	10	36	2000	
Horizontal Section	Period	T_H	2000	2104	2320	T_{Clock}
	Active	T_{HD}	1920			
	Blanking	T_{HB}	80	184	400	

Note1: The frame rate will be set to 50 Hz when SDRRS function is turned on.

6.4 Power ON/OFF Sequence

Display Port panel power sequence:

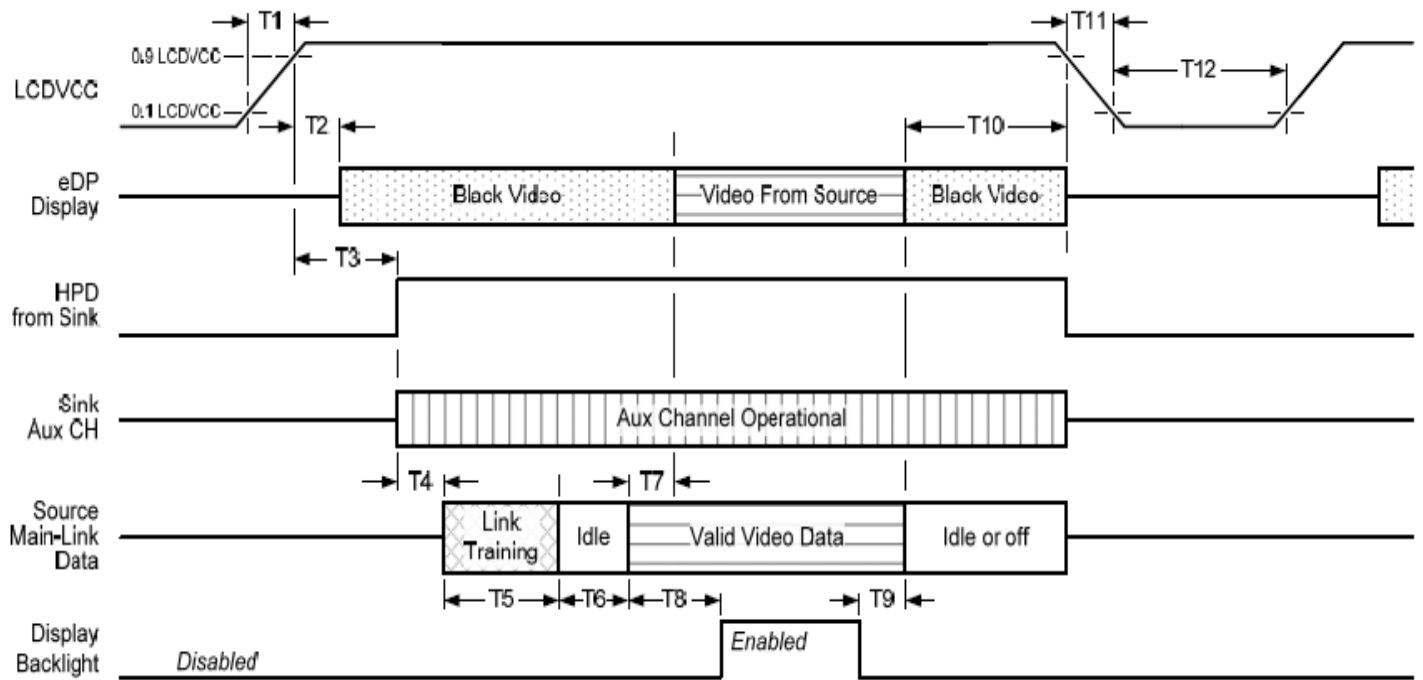

Display port interface power up/down sequence, normal system operation

Display Port AUX_CH transaction only:

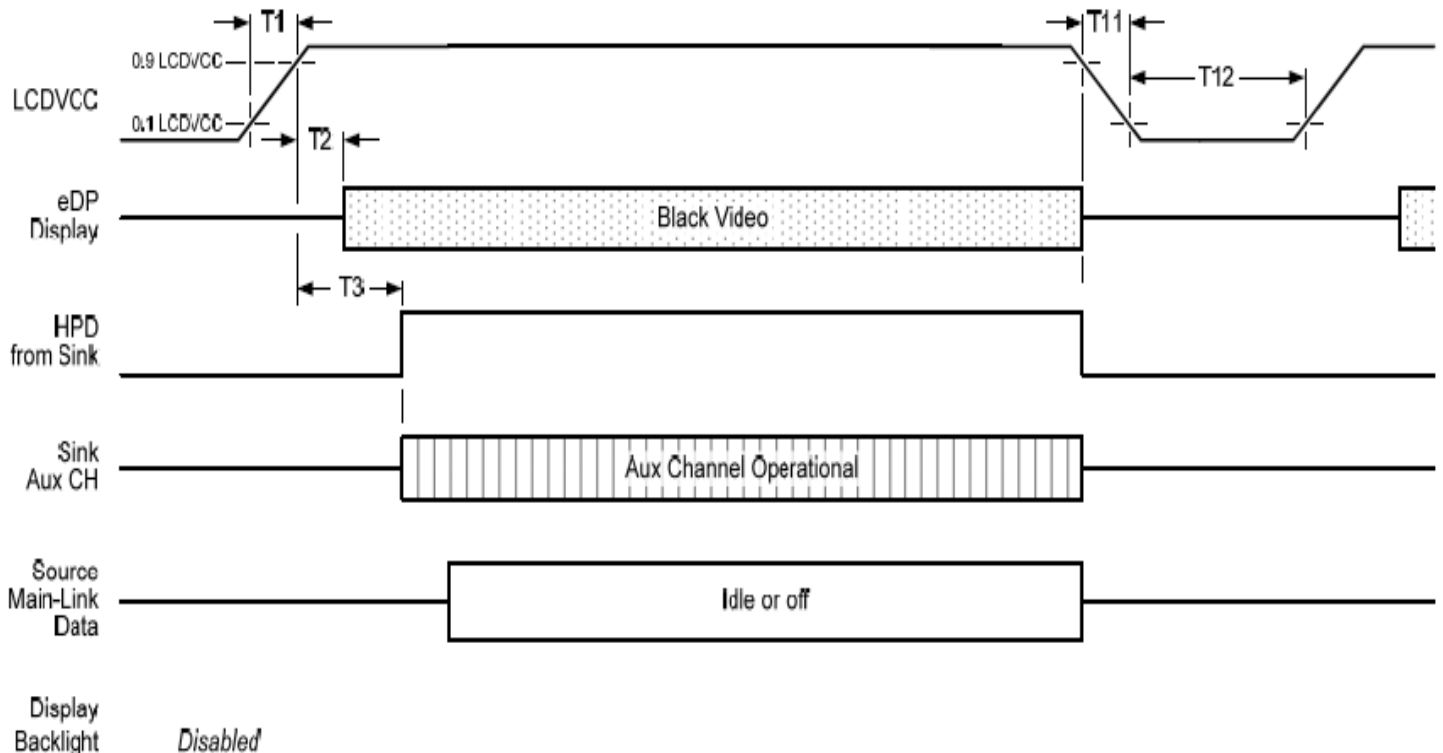

Display port interface power up/down sequence, AUX_CH transaction only



Display Port panel power sequence timing parameter:

Timing parameter	Description	Reqd. by	Limits			Notes
			Min.	Typ.	Max.	
T1	power rail rise time, 10% to 90%	source	0.5ms		10ms	
T2	delay from LCDVDD to black video generation	sink	0ms		200ms	prevents display noise until valid video data is received from the source
T3	delay from LCDVDD to HPD high	sink	0ms		200ms	sink AUX_CH must be operational upon HPD high.
T4	delay from HPD high to link training initialization	source				allows for source to read link capability and initialize.
T5	link training duration	source				dependant on source link to read training protocol.
T6	link idle	source				Min accounts for required BS-Idle pattern. Max allows for source frame synchronization.
T7	delay from valid video data from source to video on display	sink	0ms		50ms	max allows sink validate video data and timing.
T8	delay from valid video data from source to backlight enable	source				source must assure display video is stable.
T9	delay from backlight disable to end of valid video data	source				source must assure backlight is no longer illuminated.
T10	delay from end of valid video data from source to power off	source	0ms		500ms	
T11	power rail fall time, 90% to 10%	source			10ms	
T12	power off time	source	500ms			

Note1: The sink must include the ability to generate black video autonomously. The sink must automatically enable black video under the following conditions:

- upon LCDVDD power on (with in T2 max)-when the "Novideostream_Flag" (VB-ID Bit 3) is received from the source (at the end of T9).

- when no main link data, or invalid video data, is received from the source. Black video must be displayed within 64ms (typ) from the start of either condition. Video data can be deemed invalid based on MSA and timing information, for example.

Note 2: The sink may implement the ability to disable the black video function, as described in Note 1, above, for system development and debugging purpose.

Note 3: The sink must support AUX_CH polling by the source immediately following LCDVDD power on without causing damage to the sink device (the source can re-try if the sink is not ready). The sink must be able to respond to an AUX_CH transaction with the time specified within T3 max.

Display Port panel B/L power sequence timing parameter:

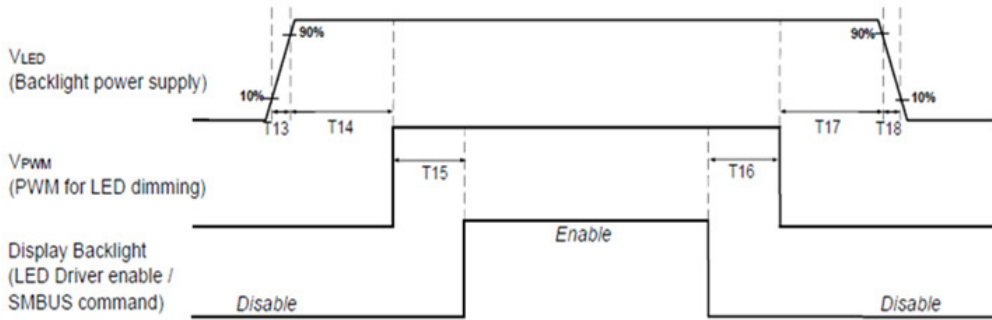

Note : When the adapter is hot plugged, the backlight power supply sequence is shown as below.

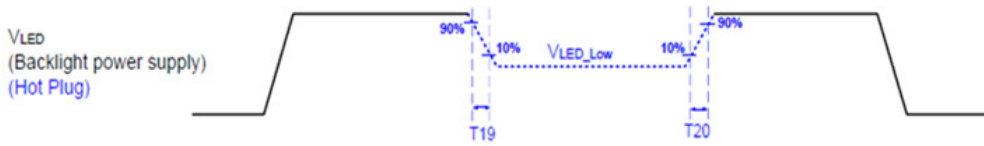

	Min (ms)	Max (ms)
T13	0.5	10
T14	10	-
T15	10	-
T16	10	-
T17	10	-
T18	0.5	10
T19	1*	-
T20	1*	-

Seamless change: $T19/T20 = 5 \times T_{PWM}^*$

* $T_{PWM} = 1/PWM \text{ Frequency}$

7. Panel Reliability Test

7.1 Vibration Test

Test Spec:

- Test method: Non-Operation
- Acceleration: 1.5 G
- Frequency: 10 - 500Hz Random
- Sweep: 30 Minutes each Axis (X, Y, Z)

7.2 Shock Test

Test Spec:

- Test method: Non-Operation
- Acceleration: 220 G , Half sine wave
- Active time: 2 ms
- Pulse: X,Y,Z .one time for each side

7.3 Reliability Test

Items	Required Condition	Note
Temperature and Humidity Bias	Ta= 40°C , 90%RH, 300h	
High Temperature Operation	Ta= 50°C , 300h	
Low Temperature Operation	Ta= 0°C , 300h	
High Temperature Storage	Ta= 60°C , 300h	
Low Temperature Storage	Ta= -20°C, RH/, 250h	
Thermal Shock Test	Ta=-20°C to 60°C, Duration at 30 min, 100 cycles	
ESD	Contact : ±8 KV Air : ±15 KV	Note 1

Note1: According to EN 61000-4-2 , ESD class B: Some performance degradation allowed. Self-recoverable.

No data lost, No hardware failures.

Remark: MTBF (Excluding the LED): 30,000 hours with a confidence level 90%

8. Mechanical Characteristics

8.1 LCM Outline Dimension

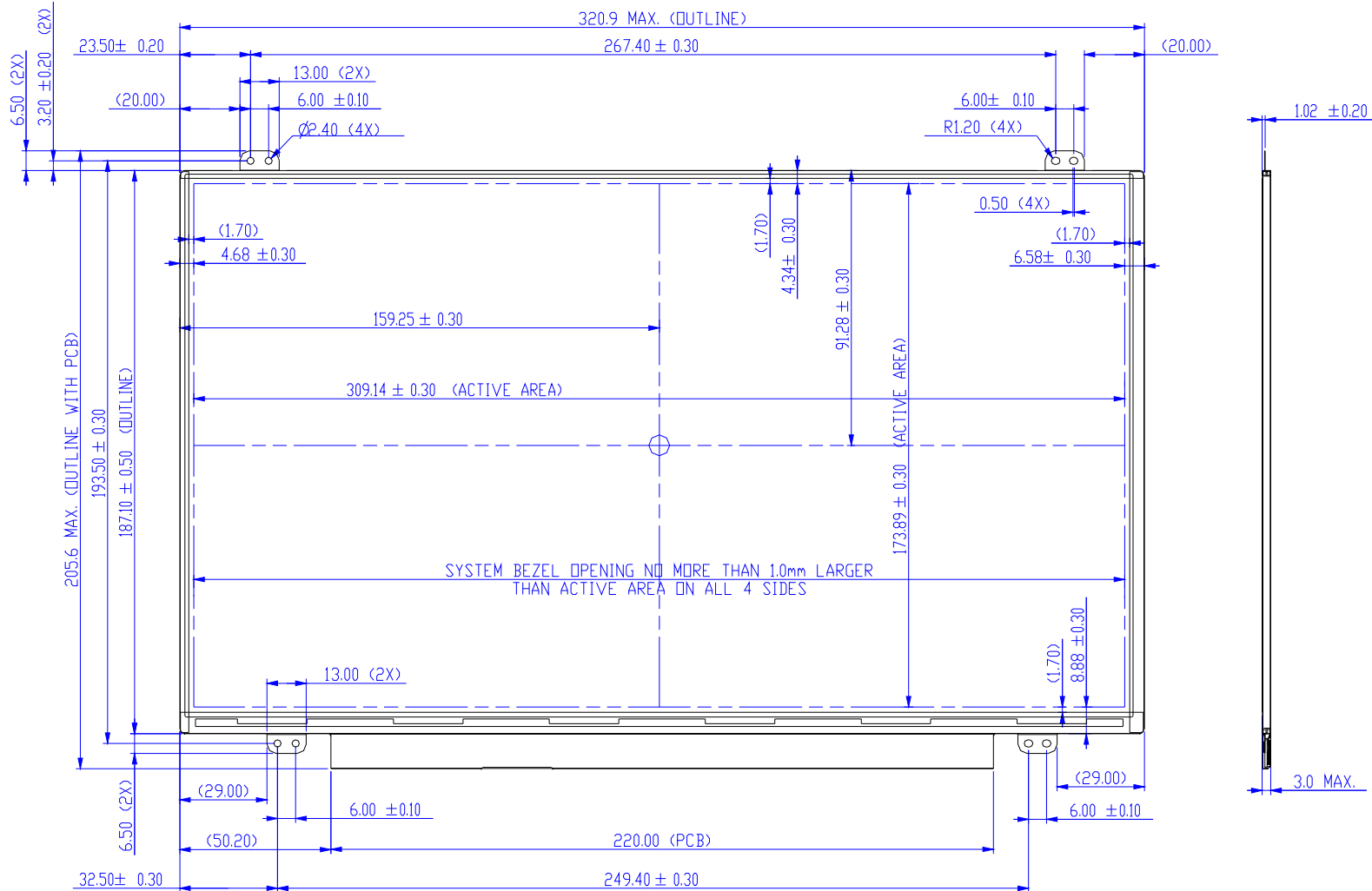

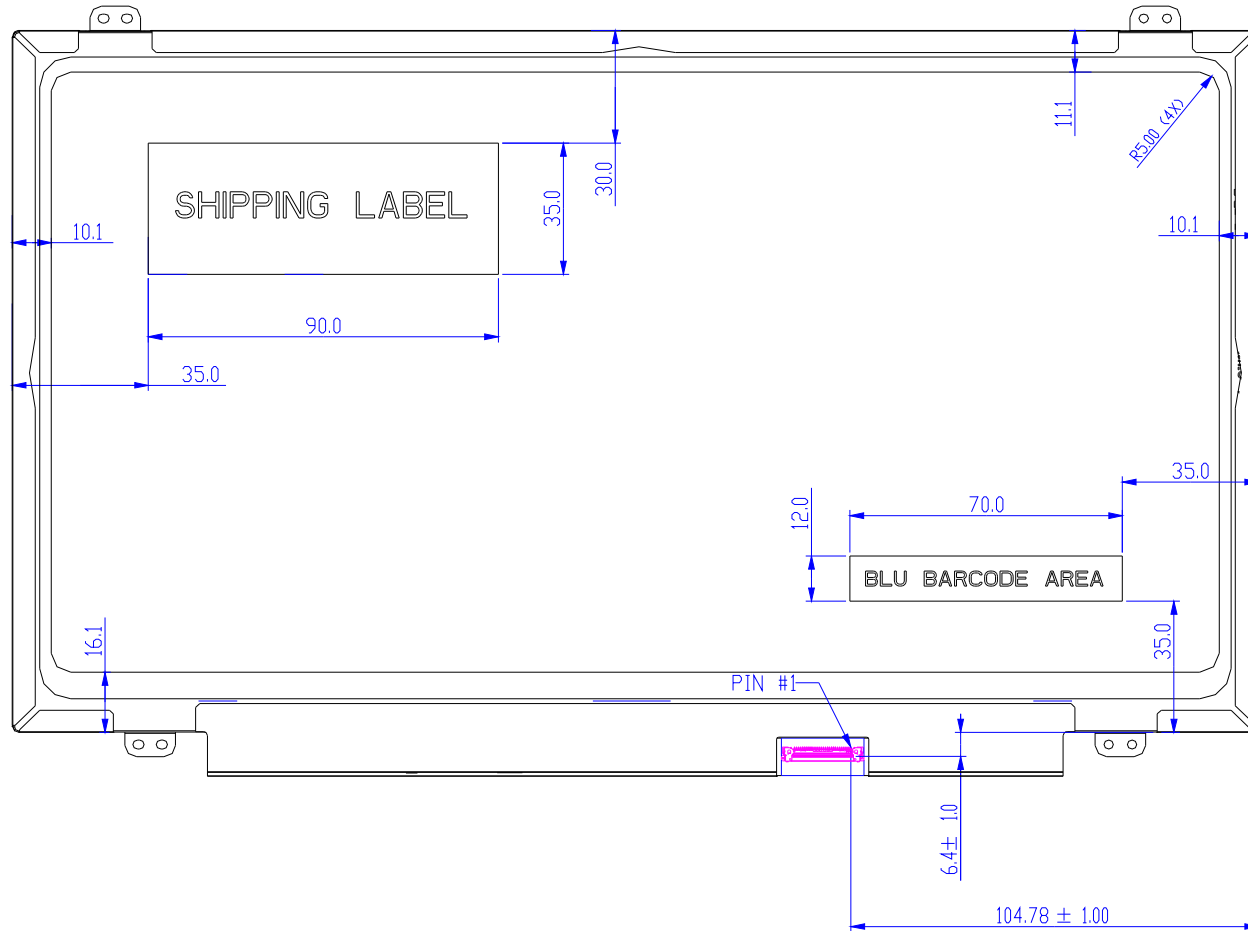





Note: Prevention IC damage, IC positions not allowed any overlap over these areas.

9. Shipping and Package

9.1 Shipping Label Format

 *XXXXXXXXXXXXXXXXXXXX*		Manufactured XXX/XX Model No: B140HAN01.3 AU Optronics MADE IN China (S01)	  
		CN- 0M1WHV -72090- XXX-XXXX- A01 Made In China DP/N 0M1WHV	HW: 1A FW:1

PKGID (3S) 720907209054P000001 0M1WHV03 		 Rev. A01
DP/N 0M1WHV 	 Vendor ID Loc ID 72090 72090	
Box Qty 40 	Made In China 	 Mfg Id 72090

9.2 Carton Package

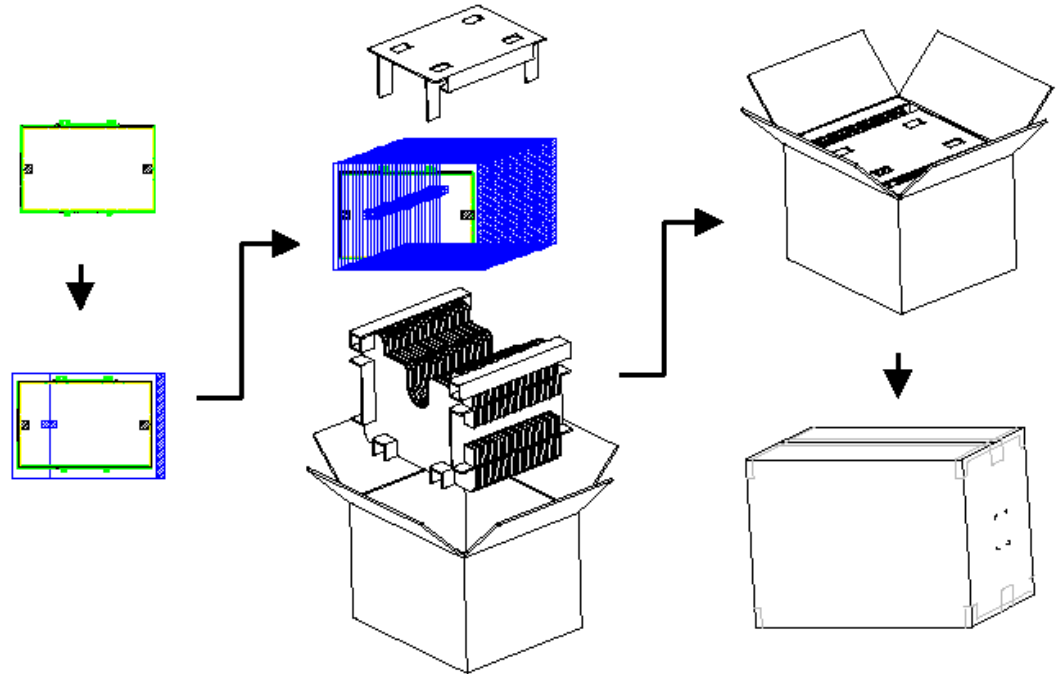

9.3 Shipping Package of Palletizing Sequence

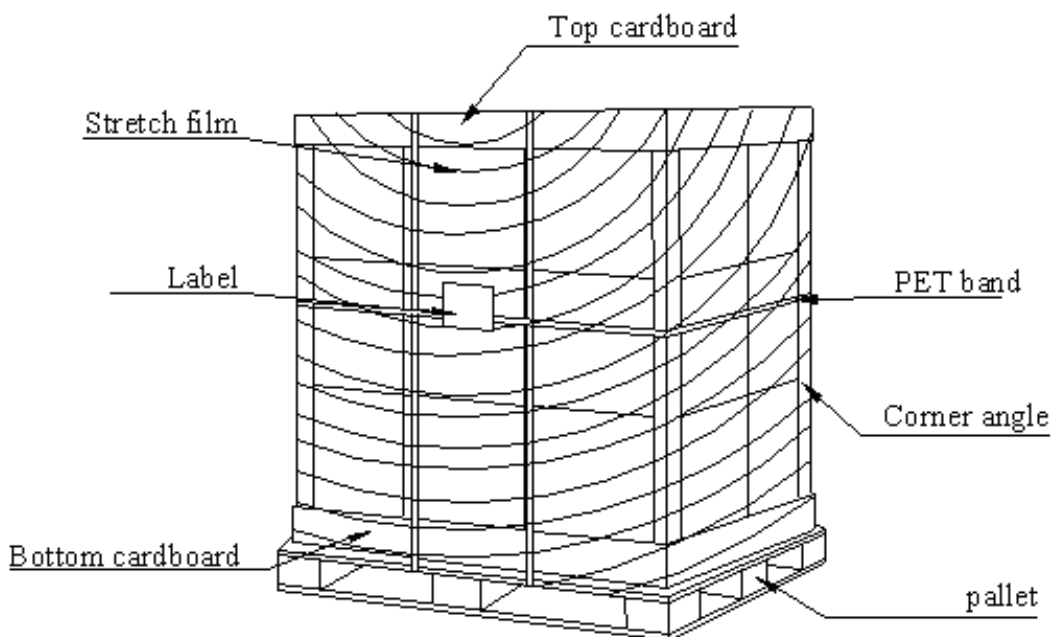

10. Appendix: EDID Description

B140HAN01 3 EDID Code					
	Byte (hex)	Field Name and Comments	Value (hex)	Value (binary)	Value (DEC)
Header	0	Header	00	00000000	0
	1	Header	FF	11111111	255
	2	Header	FF	11111111	255
	3	Header	FF	11111111	255
	4	Header	FF	11111111	255
	5	Header	FF	11111111	255
	6	Header	FF	11111111	255
	7	Header	00	00000000	0
Vendor / Product EDID Version	8	EISA manufacture code = 3 Character ID	06	00000110	6
	9	EISA manufacture code (Compressed ASCII)	AF	10101111	175
	0A	Panel Supplier Reserved – Product Code	3D	00111101	61
	0B	Panel Supplier Reserved – Product Code	13	00010011	19
	0C	LCD module Serial No - Preferred but Optional ("0" if not used)	00	00000000	0
	0D	LCD module Serial No - Preferred but Optional ("0" if not used)	00	00000000	0
	0E	LCD module Serial No - Preferred but Optional ("0" if not used)	00	00000000	0
	0F	LCD module Serial No - Preferred but Optional ("0" if not used)	00	00000000	0
	10	Week of manufacture	22	00100010	34
	11	Year of manufacture	17	00010111	23
	12	EDID structure version # = 1	01	00000001	1
	13	EDID revision # = 4	04	00000100	4
	Display Parameters	14	Video I/P definition	95	10010101
15		Max H image size = ?? cm(Rounded to cm)	1F	00011111	31
16		Max V image size = ?? cm(Rounded to cm)	11	00010001	17
17		Display gamma = (gamma ×100)-100 = Example: (2.2×100) – 100 = 120	78	01111000	120
18		Feature support	02	00000010	2
Panel Color Coordinates	19	Red/Green Low bit (RxRy/GxGy)	87	10000111	135
	1A	Blue/White Low bit (BxBY/WxWy)	E5	11100101	229
	1B	Red X Rx = 0.???	A4	10100100	164
	1C	Red Y Ry = 0.???	56	01010110	86
	1D	Green X Rx = 0.???	50	01010000	80
	1E	Green Y Ry = 0.???	9E	10011110	158
	1F	Blue X Rx = 0.???	26	00100110	38
	20	Blue Y Ry = 0.???	0D	00001101	13
	21	White X Rx = 0.???	50	01010000	80
	22	White Y Ry = 0.???	54	01010100	84
Established Timings	23	Established timings 1 (00h if not used)	00	00000000	0
	24	Established timings 2 (00h if not used)	00	00000000	0
	25	Manufacturer's timings (00h if not used)	00	00000000	0
Standard Timing ID	26	Standard timing ID1 (01h if not used)	01	00000001	1
	27	Standard timing ID1 (01h if not used)	01	00000001	1
	28	Standard timing ID2 (01h if not used)	01	00000001	1
	29	Standard timing ID2 (01h if not used)	01	00000001	1
	2A	Standard timing ID3 (01h if not used)	01	00000001	1
	2B	Standard timing ID3 (01h if not used)	01	00000001	1
	2C	Standard timing ID4 (01h if not used)	01	00000001	1
	2D	Standard timing ID4 (01h if not used)	01	00000001	1
	2E	Standard timing ID5 (01h if not used)	01	00000001	1
	2F	Standard timing ID5 (01h if not used)	01	00000001	1
	30	Standard timing ID6 (01h if not used)	01	00000001	1
	31	Standard timing ID6 (01h if not used)	01	00000001	1
	32	Standard timing ID7 (01h if not used)	01	00000001	1
	33	Standard timing ID7 (01h if not used)	01	00000001	1
	34	Standard timing ID8 (01h if not used)	01	00000001	1
	35	Standard timing ID8 (01h if not used)	01	00000001	1



Product Specification

AU OPTRONICS CORPORATION

	Byte (hex)	Field Name and Comments	Value (hex)	Value (binary)	Value (DEC)
Timing Descriptor #1	36	Pixel Clock/10,000 (LSB)	14	00010100	20
	37	Pixel Clock/10,000 (MSB)	37	00110111	55
	38	Horizontal Active = ???? pixels (lower 8 bits)	80	10000000	128
	39	Horizontal Blanking (Thbp) = 320 pixels (lower 8 bits)	B8	10111000	184
	3A	Horizontal Active/Horizontal blanking (Thbp) (upper4:4 bits)	70	01110000	112
	3B	Vertical Active = ??? lines	38	00111000	56
	3C	Vertical Blanking (Tvbp) = ?? lines (DE Blanking typ. for DE only panels)	24	00100100	36
	3D	Vertical Active : Vertical Blanking (Tvbp) (upper4:4 bits)	40	01000000	64
	3E	Horizontal Sync, Offset (Thfp) = ?? pixels	10	00010000	16
	3F	Horizontal Sync, Pulse Width = ??? pixels	10	00010000	16
	40	Vertical Sync, Offset (Tvfp) = ? lines Sync Width = ? lines	3E	00111110	62
	41	Horizontal Vertical Sync Offset/Width upper 2 bits	00	00000000	0
	42	Horizontal Image Size = ??? mm	35	00110101	53
	43	Vertical image Size = ??? mm	AD	10101101	173
	44	Horizontal Image Size / Vertical image size	10	00010000	16
	45	Horizontal Border = 0 (Zero for Notebook LCD)	00	00000000	0
	46	Vertical Border = 0 (Zero for Notebook LCD)	00	00000000	0
		Bit[7] 0: Non-interlace, 1: Interlace Bit[6:5] 00: Normal display, no stereo, see VESA EDID Spec 1.3 Bit[4:3] 00: Analog composite, 01: Bipolar analog composite, 10: Digital composite, 11: Digital separate			
47	Bit[2:1] : The int	1A	00011010	26	
Timing Descriptor #2 (=Timing Descriptor #1)	48	Pixel Clock/10,000 (LSB)	10	00010000	16
	49	Pixel Clock/10,000 (MSB)	2C	00101100	44
	4A	Horizontal Active = xxx pixels (lower 8 bits)	80	10000000	128
	4B	Horizontal Blanking (Thbp) = xxx pixels (lower 8 bits)	B8	10111000	184
	4C	Horizontal Active/Horizontal blanking (Thbp) (upper4:4 bits)	70	01110000	112
	4D	Vertical Active = xxx lines	38	00111000	56
	4E	Vertical Blanking (Tvbp) = xxx lines (DE Blanking typ. for DE only panels)	24	00100100	36
	4F	Vertical Active : Vertical Blanking (Tvbp) (upper4:4 bits)	40	01000000	64
	50	Horizontal Sync, Offset (Thfp) = xxx pixels	10	00010000	16
	51	Horizontal Sync, Pulse Width = xxx pixels	10	00010000	16
	52	Vertical Sync, Offset (Tvfp) = xx lines Sync Width = xx lines	3E	00111110	62
	53	Horizontal Vertical Sync Offset/Width upper 2 bits	00	00000000	0
	54	Horizontal Image Size = xxx mm	35	00110101	53
	55	Vertical image Size = xxx mm	AD	10101101	173
	56	Horizontal Image Size / Vertical image size	10	00010000	16
	57	Horizontal Border = 0 (Zero for Notebook LCD)	00	00000000	0
	58	Vertical Border = 0 (Zero for Notebook LCD)	00	00000000	0
		Bit[7] 0: Non-interlace, 1: Interlace Bit[6:5] 00: Normal display, no stereo, see VESA EDID Spec 1.3 Bit[4:3] 00: Analog composite, 01: Bipolar analog composite, 10: Digital composite, 11: Digital separate			
59	Bit[2:1] : The int	1A	00011010	26	
Timing Descriptor #3 Dell specific information	5A	Flag	00	00000000	0
	5B	Flag	00	00000000	0
	5C	Flag	00	00000000	0
	5D	Data Type Tag: Alphanumeric Data String (ASCII) ==> fix=FE	FE	11111110	254
	5E	Flag	00	00000000	0
	5F	Dell P/N 1 st Character	4D	01001101	77
	60	Dell P/N 2 nd Character	31	00110001	49
	61	Dell P/N 3 rd Character	57	01010111	87
	62	Dell P/N 4 th Character	48	01001000	72
	63	Dell P/N 5 th Character	56	01010110	86
		EDID Revision Bit[6:0] See charts below Bit[7] 0: X-rev, 1: A-rev			
	64	Manufacturer P/N	81	10000001	129
	65	Manufacturer P/N	42	01000010	66
	66	Manufacturer P/N	31	00110001	49
67	Manufacturer P/N	34	00110100	52	
68	Manufacturer P/N	30	00110000	48	
69	Manufacturer P/N	48	01001000	72	
6A	Manufacturer P/N	41	01000001	65	
6B	Manufacturer P/N (If <13 char, then terminate with ASCII code 0Ah, set remaining char = 20h)	4E	01001110	78	



Product Specification

AU OPTRONICS CORPORATION

	Byte	Field Name and Comments	Value	Value	Value
	(hex)		(hex)	(binary)	(DEC)
Timing Descriptor #4	6C	Flag	00	00000000	0
	6D	Flag	00	00000000	0
	6E	Flag	00	00000000	0
	6F	Data Type Tag: Manufacturer Specified Data 00 ==>fix=00	00	00000000	0
	70	Flag	00	00000000	0
	71	Color Management	00	00000000	0
	72	Panel Structure	41	01000001	65
	73	Frame Rate	21	00100001	33
	74	Light Controller Interface and Luminance	9E	10011110	158
	75	Outdoor Features	00	00000000	0
	76	Multi-Media Features	00	00000000	0
	77	Multi-Media Features	00	00000000	0
	78	Special Features #1	00	00000000	0
	79	Special Features #2	0A	00001010	10
	7A	Special Features #3	01	00000001	1
Checksum	7B	(If <13 char, then terminate with ASCII code 0Ah, set remaining char = 20h)	0A	00001010	10
	7C	(If <13 char, then terminate with ASCII code 0Ah, set remaining char = 20h)	20	00100000	32
	7D	(If <13 char, then terminate with ASCII code 0Ah, set remaining char = 20h)	20	00100000	32
	7E	Extension flag (# of optional 128 EDID extension blocks to follow, Typ = 0)	00	00000000	0
	7F	Checksum (The 1-byte sum of all 128 bytes in this EDID block shall = 0)	71	01110001	113