



Product Specification

AU OPTRONICS CORPORATION

(V) Preliminary Specifications

() Final Specifications

Module	14.0" (13.98") HD+ 16:9 Color TFT-LCD with LED Backlight design
Model Name	B140RW03 V0 (H/W:0A)
Note ()	<i>LED Backlight with driving circuit design</i>

Customer	Date
Checked & Approved by	Date
Note: This Specification is subject to change without notice.	

Approved by	Date
<u>Bonnie Chen</u>	<u>02/11/2011</u>
Prepared by	Date
<u>HsinYin Yu</u>	<u>02/11/2011</u>
NBBU Marketing Division AU Optronics corporation	



Product Specification

AU OPTRONICS CORPORATION

Contents

1. Handling Precautions	4
2. General Description	5
2.1 General Specification	5
2.2 Optical Characteristics	6
3. Functional Block Diagram	11
4. Absolute Maximum Ratings.....	12
4.1 Absolute Ratings of TFT LCD Module	12
4.2 Absolute Ratings of Environment	12
5. Electrical Characteristics.....	13
5.1 TFT LCD Module.....	13
5.2 Backlight Unit	15
6. Signal Interface Characteristic.....	16
6.1 Pixel Format Image	16
6.2 The Input Data Format	17
6.3 Integration Interface Requirement.....	19
6.4 Interface Timing	21
7. Panel Reliability Test.....	24
7.1 Vibration Test	24
7.2 Shock Test	24
7.3 Reliability Test.....	24
8. Mechanical Characteristics.....	25
8.1 LCM Outline Dimension.....	25
9. Shipping and Package	27
9.1 Shipping /Carton Label Format.....	27
9.2 Carton Package.....	28
9.3 Shipping Package of Palletizing Sequence.....	28
10. Appendix: EDID Description	29



Product Specification

AU OPTRONICS CORPORATION

Record of Revision

Version and Date	Page	Old description	New Description	Remark
0.1 2010/10/05	All	First Edition for Customer		
0.2 2011/02/11	5-6	General Specification TBD	Update Specification	
	13	Power Specification TBD	Update Power Specification	
	15	BLU power TBD	Update BLU power	
	19	Mating Housing TBD	Update Mating Housing	



Product Specification

AU OPTRONICS CORPORATION

1. Handling Precautions

- 1) Since front polarizer is easily damaged, pay attention not to scratch it.
- 2) Be sure to turn off power supply when inserting or disconnecting from input connector.
- 3) Wipe off water drop immediately. Long contact with water may cause discoloration or spots.
- 4) When the panel surface is soiled, wipe it with absorbent cotton or other soft cloth.
- 5) Since the panel is made of glass, it may break or crack if dropped or bumped on hard surface.
- 6) Since CMOS LSI is used in this module, take care of static electricity and insure human earth when handling.
- 7) Do not open nor modify the Module Assembly.
- 8) Do not press the reflector sheet at the back of the module to any directions.
- 9) At the insertion or removal of the Signal Interface Connector, be sure not to rotate nor tilt the Interface Connector of the TFT Module.
- 11) After installation of the TFT Module into an enclosure (Notebook PC Bezel, for example), do not twist nor bend the TFT Module even momentary. At designing the enclosure, it should be taken into consideration that no bending/twisting forces are applied to the TFT Module from outside. Otherwise the TFT Module may be damaged.
- 12) Small amount of materials having no flammability grade is used in the LCD module. The LCD module should be supplied by power complied with requirements of Limited Power Source (IEC60950 or UL1950), or be applied exemption.
- 13) Disconnecting power supply before handling LCD modules, it can prevent electric shock, DO NOT TOUCH the electrode parts, cables, connectors and LED circuit part of TFT module that a LED light bar build in as a light source of back light unit. It can prevent electrostatic breakdown.



Product Specification

AU OPTRONICS CORPORATION

2. General Description

B140RW03 V0 is a Color Active Matrix Liquid Crystal Display composed of a TFT LCD panel, a driver circuit, and LED backlight system. The screen format is intended to support the 16:9 HD, 1600(H) x900(V) screen and 262k colors (RGB 6-bits data driver) with LED backlight driving circuit. All input signals are LVDS interface compatible.

B140RW03 V0 is designed for a display unit of notebook style personal computer and industrial machine.

2.1 General Specification

The following items are characteristics summary on the table at 25 °C condition:

Items	Unit	Specifications			
Screen Diagonal	[mm]	354.95			
Active Area	[mm]	309.60 X 174.15			
Pixels H x V		1600x3(RGB) x 900			
Pixel Pitch	[mm]	0.1935X0.1935			
Pixel Format		R.G.B. Vertical Stripe			
Display Mode		Normally White			
White Luminance (ILED=20mA) (Note: ILED is LED current)	[cd/m ²]	200 typ. (5 points average)			
Luminance Uniformity		1.25 max. (5 points)			
Contrast Ratio		400 typ.			
Response Time	[ms]	8 typ / 16 Max			
Nominal Input Voltage VDD	[Volt]	+3.3 typ.			
Power Consumption	[Watt]	4.3 W (Include Logic and Blu power)			
Weight	[Grams]	350 max.			
Physical Size Include bracket	[mm]		Min.	Typ.	Max.
		Length			324
		Width			193
		Thickness			5.2
Electrical Interface		2 channel LVDS			
Glass Thickness	[mm]	0.5			
Surface Treatment		Anti-Glare, Hardness 3H,			
Support Color		262K colors (RGB 6-bit)			



Product Specification

AU OPTRONICS CORPORATION

Temperature Range Operating Storage (Non-Operating)	[°C] [°C]	0 to +50 -20 to +60
RoHS Compliance		RoHS Compliance

2.2 Optical Characteristics

The optical characteristics are measured under stable conditions at 25°C (Room Temperature) :

Item	Symbol	Conditions	Min.	Typ.	Max.	Unit	Note	
White Luminance $I_{LED=20mA}$		5 points average	170	200	-	cd/m ²	1, 4, 5.	
Viewing Angle	θ_R θ_L	Horizontal (Right) CR = 10 (Left)	40 40	45 45	- -	degree	4, 9	
	ψ_H ψ_L	Vertical (Upper) CR = 10 (Lower)	10 30	15 35	- -			
Luminance Uniformity	δ_{5P}	5 Points	-	-	1.25		1, 3, 4	
Luminance Uniformity	δ_{13P}	13 Points	-	-	1.50		2, 3, 4	
Contrast Ratio	CR		300	400	-		4, 6	
Cross talk	%				4		4, 7	
Response Time	T_r	Rising	-			msec	4, 8	
	T_f	Falling	-					
	T_{RT}	Rising + Falling	-	8	16			
Color / Chromaticity Coordinates	Red	Rx	CIE 1931	0.580	0.610	0.640	-	4
		Ry		0.320	0.350	0.380		
	Green	Gx		0.290	0.320	0.350		
		Gy		0.530	0.560	0.590		
	Blue	Bx		0.120	0.150	0.180		
		By		0.100	0.130	0.160		
	White	Wx		0.283	0.313	0.343		
		Wy		0.299	0.329	0.359		
NTSC	%		45					



Product Specification

AU OPTRONICS CORPORATION

Note 1: 5 points position (Ref: Active area)

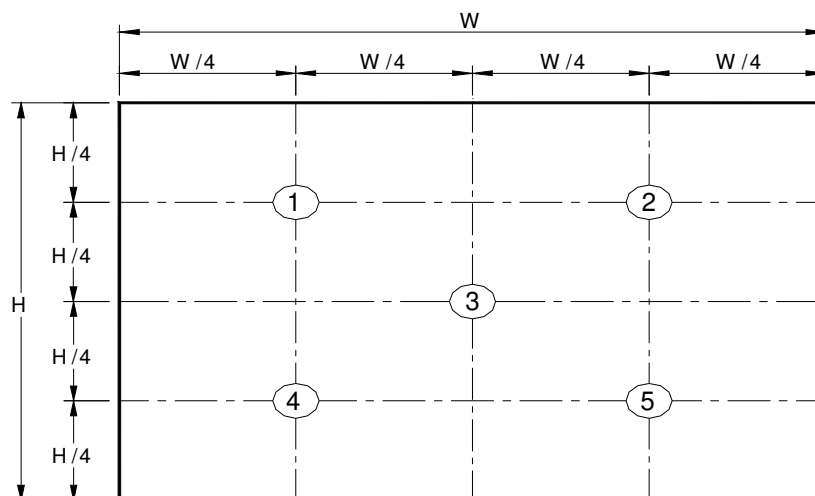

Note 2: 13 points position (Ref: Active area)

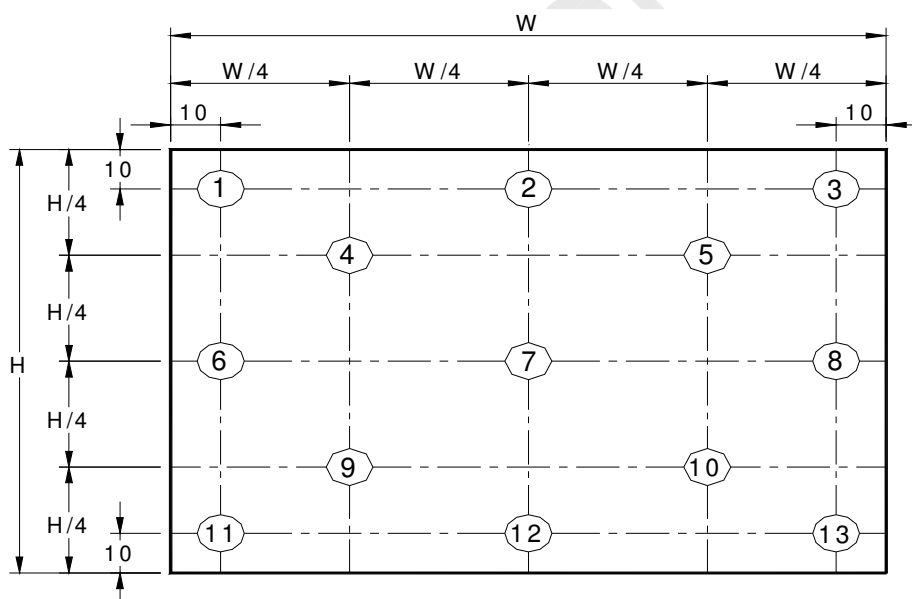

Note 3: The luminance uniformity of 5 or 13 points is defined by dividing the maximum luminance values by the minimum test point luminance

$$\delta_{W5} = \frac{\text{Maximum Brightness of five points}}{\text{Minimum Brightness of five points}}$$

$$\delta_{W13} = \frac{\text{Maximum Brightness of thirteen points}}{\text{Minimum Brightness of thirteen points}}$$

Note 4: Measurement method

The LCD module should be stabilized at given temperature for 30 minutes to avoid abrupt temperature change during measuring. In order to stabilize the luminance, the measurement should be executed after lighting



Product Specification

AU OPTRONICS CORPORATION

Backlight for 30 minutes in a stable, windless and dark room, and it should be measured in the center of screen.

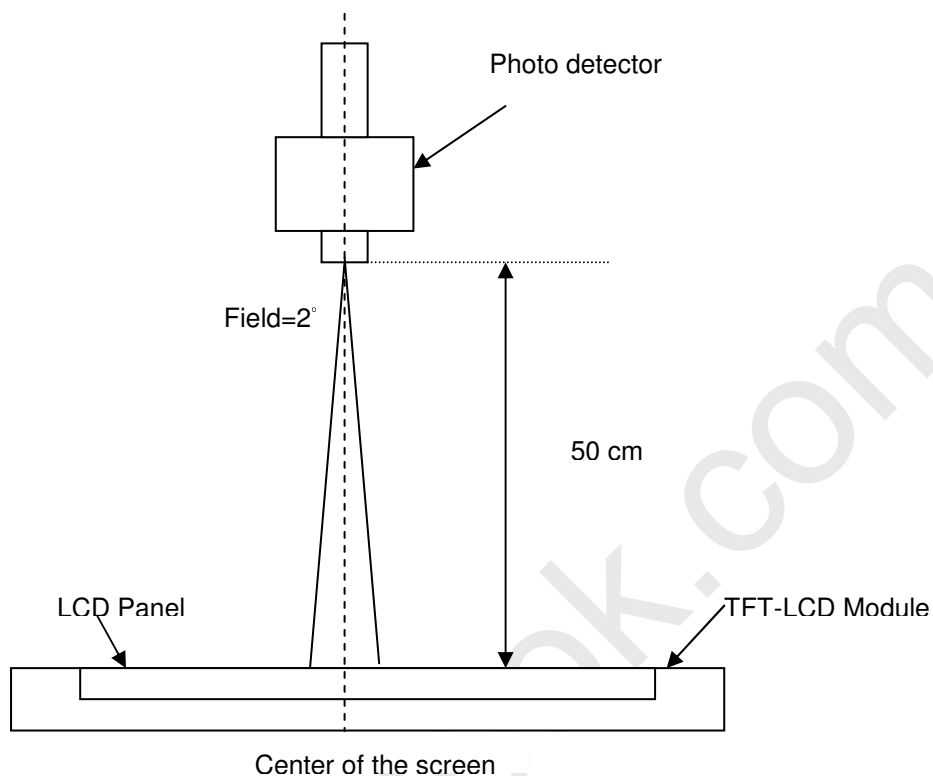

Note 5 : Definition of Average Luminance of White (Y_L):

Measure the luminance of gray level 63 at 5 points , $Y_L = [L(1) + L(2) + L(3) + L(4) + L(5)] / 5$

$L(x)$ is corresponding to the luminance of the point X at Figure in Note (1).

Note 6 : Definition of contrast ratio:

Contrast ratio is calculated with the following formula.

$$\text{Contrast ratio (CR)} = \frac{\text{Brightness on the "White" state}}{\text{Brightness on the "Black" state}}$$

Note 7 : Definition of Cross Talk (CT)

$$CT = |Y_B - Y_A| / Y_A \times 100 (\%)$$

Where

Y_A = Luminance of measured location without gray level 0 pattern (cd/m^2)

Y_B = Luminance of measured location with gray level 0 pattern (cd/m^2)



Product Specification

AU OPTRONICS CORPORATION

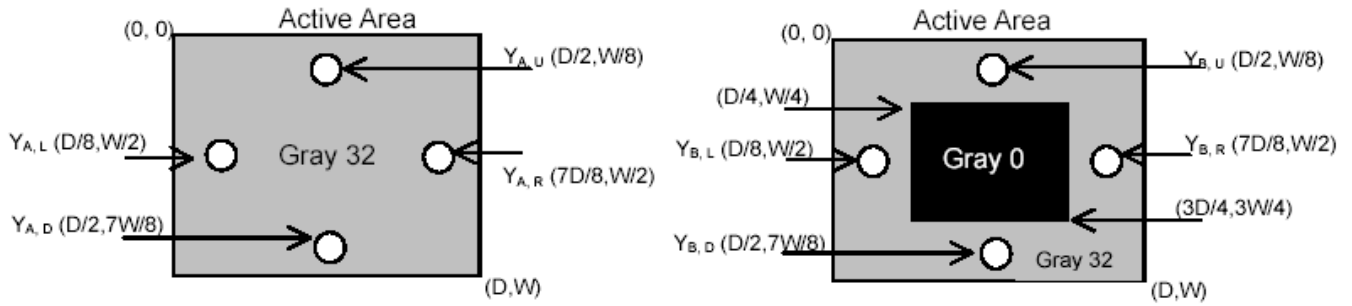

Note 8: Definition of response time:

The output signals of BM-7 or equivalent are measured when the input signals are changed from "Black" to "White" (falling time) and from "White" to "Black" (rising time), respectively. The response time interval between the 10% and 90% of amplitudes. Refer to figure as below.

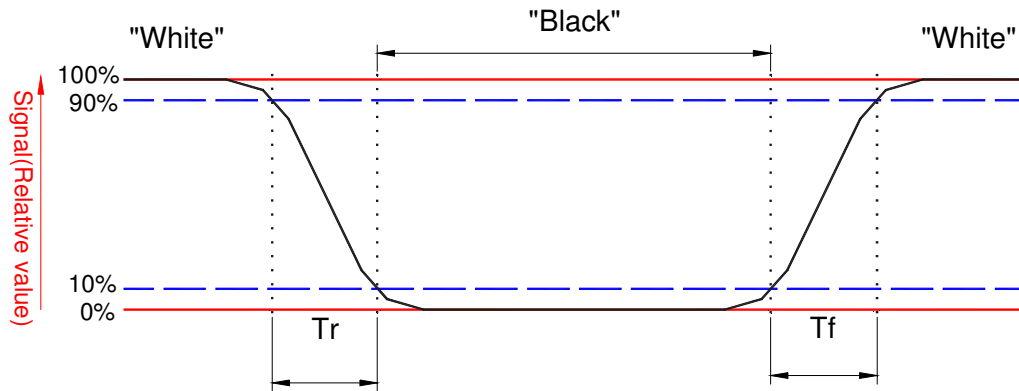



Product Specification

AU OPTRONICS CORPORATION

Note 9. Definition of viewing angle

Viewing angle is the measurement of contrast ratio ≥ 10 , at the screen center, over a 180° horizontal and 180° vertical range (off-normal viewing angles). The 180° viewing angle range is broken down as follows; 90° (θ) horizontal left and right and 90° (Φ) vertical, high (up) and low (down). The measurement direction is typically perpendicular to the display surface with the screen rotated about its center to develop the desired measurement viewing angle.

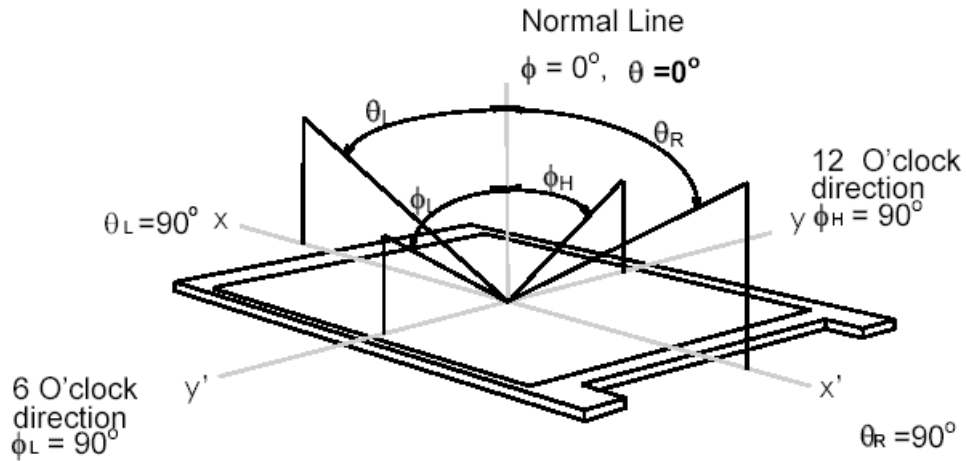



Product Specification

AU OPTRONICS CORPORATION

3. Functional Block Diagram

The following diagram shows the functional block of the 14.0 inches wide Color TFT/LCD 40 Pin one channel Module

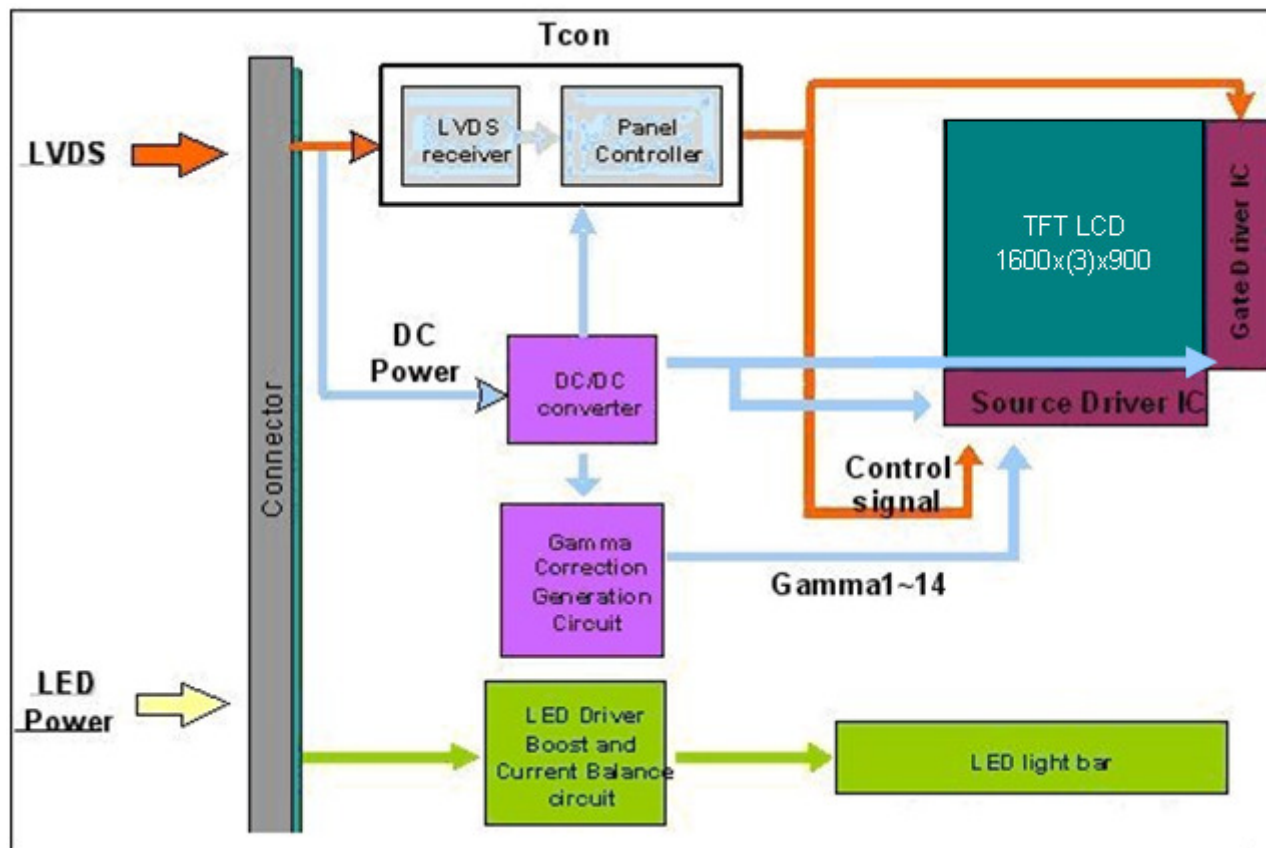



Product Specification

AU OPTRONICS CORPORATION

4. Absolute Maximum Ratings

An absolute maximum rating of the module is as following:

4.1 Absolute Ratings of TFT LCD Module

Item	Symbol	Min	Max	Unit	Conditions
Logic/LCD Drive Voltage	Vin	-0.3	+4.0	[Volt]	Note 1,2

4.2 Absolute Ratings of Environment

Item	Symbol	Min	Max	Unit	Conditions
Operating Temperature	TOP	0	+50	[°C]	Note 4
Operation Humidity	HOP	5	95	[%RH]	Note 4
Storage Temperature	TST	-20	+60	[°C]	Note 4
Storage Humidity	HST	5	95	[%RH]	Note 4

Note 1: At Ta (25°C)

Note 2: Permanent damage to the device may occur if exceed maximum values

Note 3: LED specification refer to section 5.2

Note 4: For quality performance, please refer to AUO IIS (Incoming Inspection Standard).

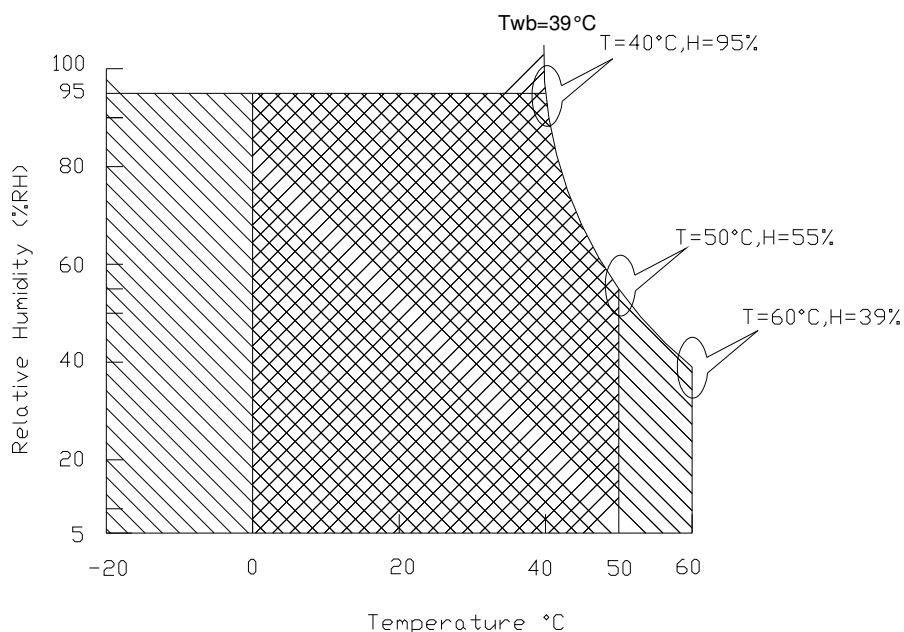

Operating Range 

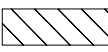
Storage Range  + 



Product Specification

AU OPTRONICS CORPORATION

5. Electrical Characteristics

5.1 TFT LCD Module

5.1.1 Power Specification

Input power specifications are as follows;

The power specification are measured under 25°C and frame frequency under 60Hz

Symble	Parameter	Min	Typ	Max	Units	Note
VDD	Logic/LCD Drive Voltage	3.0	3.3	3.6	[Volt]	
PDD	VDD Power	-	-	1.3	[Watt]	Note 1
IDD	IDD Current	-	-	0.43	[mA]	Note 1
IRush	Inrush Current	-	-	2000	[mA]	Note 2
VDDrp	Allowable Logic/LCD Drive Ripple Voltage	-	-	100	[mV] p-p	

Note 1 : Maximum Measurement Condition : Black Pattern at 3.3V driving voltage. ($P_{max}=V_{3.3} \times I_{black}$)

Note 2 : Measure Condition

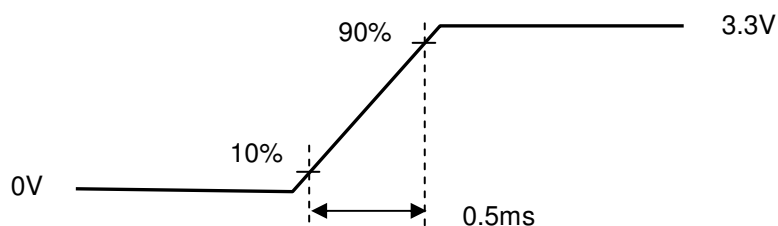
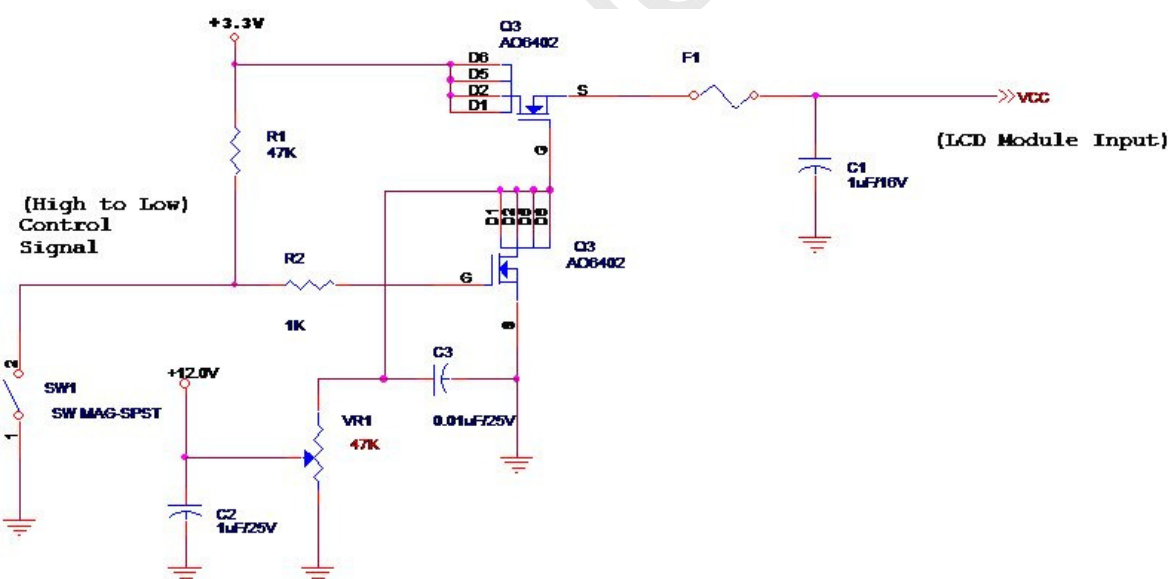

Vin rising time



Product Specification

AU OPTRONICS CORPORATION

5.1.2 Signal Electrical Characteristics

Signal electrical characteristics are as follows;

Parameter	Condition	Min	Max	Unit
V_{TH}	Differential Input High Threshold ($V_{cm}=+1.2V$)		100	[mV]
V_{TL}	Differential Input Low Threshold ($V_{cm}=+1.2V$)	-100	-	[mV]
V_{CM}	Differential Input Common Mode Voltage	1.125	1.375	[V]

Note: LVDS Signal Waveform

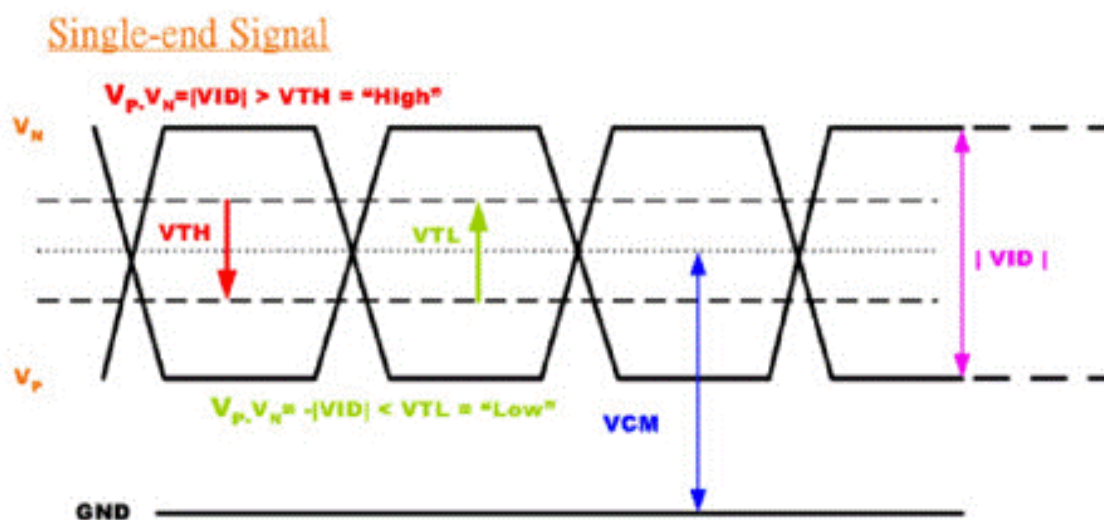



Product Specification

AU OPTRONICS CORPORATION

5.2 Backlight Unit

5.2.1 LED characteristics

Parameter	Symbol	Min	Typ	Max	Units	Condition
Backlight Power Consumption	PLED	-	-	3.0	[Watt]	(Ta=25°C), Note 1 Vin =12V
LED Life-Time	N/A	10000	-	-	Hour	(Ta=25°C), Note 2 If=20 mA

Note 1: Calculator value for reference $P_{LED} = V_F$ (Normal Distribution) * I_F (Normal Distribution) / Efficiency

Note 2: The LED life-time define as the estimated time to 50% degradation of initial luminous.

5.2.2 Backlight input signal characteristics

Parameter	Symbol	Min	Typ	Max	Units	Remark
LED Power Supply	VLED	6.0	12.0	21.0	[Volt]	Define as Connector Interface (Ta=25°C)
LED Enable Input High Level	VLED_EN	2.5	-	5.5	[Volt]	
LED Enable Input Low Level		-	-	0.8	[Volt]	
PWM Logic Input High Level	VPWM_EN	2.5	-	5.5	[Volt]	
PWM Logic Input Low Level		-	-	0.8	[Volt]	
PWM Input Frequency	FPWM	200	-	20K	Hz	
PWM Duty Ratio	Duty	5	--	100	%	



Product Specification

AU OPTRONICS CORPORATION

6. Signal Interface Characteristic

6.1 Pixel Format Image

Following figure shows the relationship of the input signals and LCD pixel format.

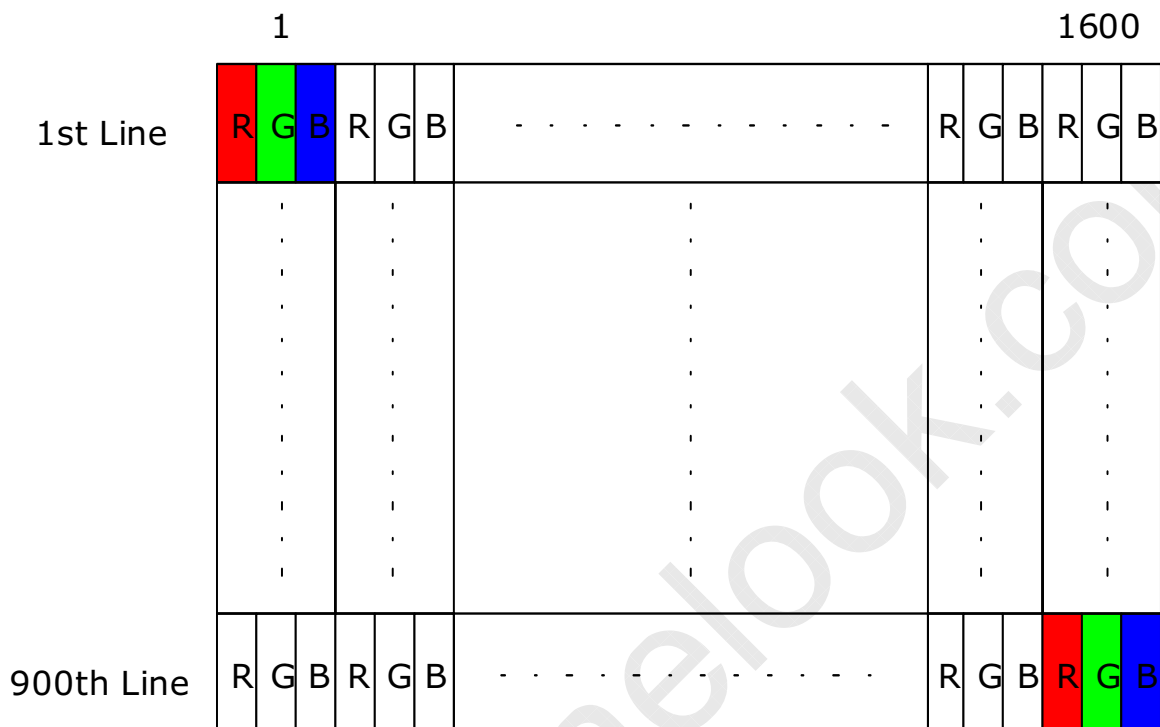



Product Specification

AU OPTRONICS CORPORATION

6.2 The Input Data Format

ODD pair(1st pixel input)

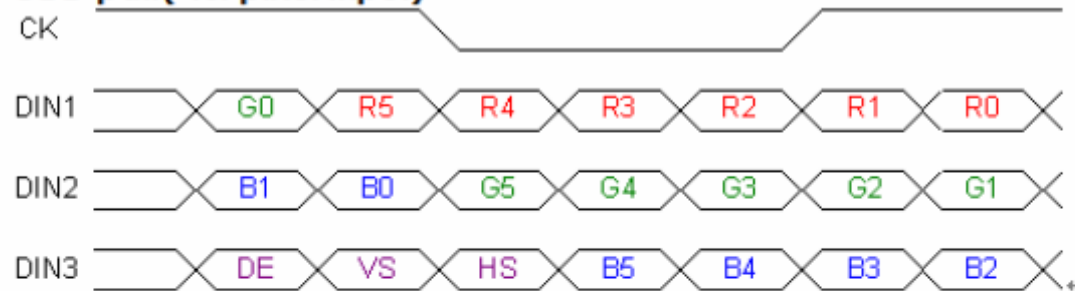

Even pair(2nd pixel input)

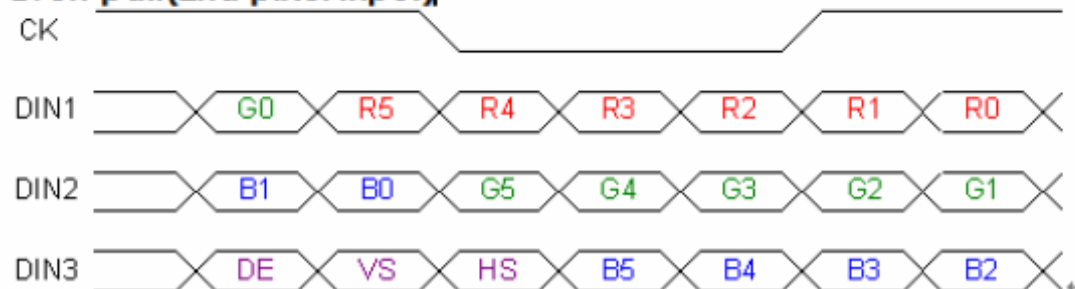



Product Specification

AU OPTRONICS CORPORATION

Signal Name	Description	
R5 R4 R3 R2 R1 R0	Red Data 5 (MSB) Red Data 4 Red Data 3 Red Data 2 Red Data 1 Red Data 0 (LSB)	Red-pixel Data Each red pixel's brightness data consists of these 6 bits pixel data.
	Red-pixel Data	
G5 G4 G3 G2 G1 G0	Green Data 5 (MSB) Green Data 4 Green Data 3 Green Data 2 Green Data 1 Green Data 0 (LSB)	Green-pixel Data Each green pixel's brightness data consists of these 6 bits pixel data.
	Green-pixel Data	
B5 B4 B3 B2 B1 B0	Blue Data 5 (MSB) Blue Data 4 Blue Data 3 Blue Data 2 Blue Data 1 Blue Data 0 (LSB)	Blue-pixel Data Each blue pixel's brightness data consists of these 6 bits pixel data.
	Blue-pixel Data	
RxCLKIN	Data Clock	The signal is used to strobe the pixel data and DE signals. All pixel data shall be valid at the falling edge when the DE signal is high.
DE	Display Timing	This signal is strobed at the falling edge of RxCLKIN. When the signal is high, the pixel data shall be valid to be displayed.
VS	Vertical Sync	The signal is synchronized to RxCLKIN .
HS	Horizontal Sync	The signal is synchronized to RxCLKIN .

Note: Output signals from any system shall be low or High-impedance state when VDD is off.



Product Specification

AU OPTRONICS CORPORATION

6.3 Integration Interface Requirement

6.3.1 Connector Description

Physical interface is described as for the connector on module.

These connectors are capable of accommodating the following signals and will be following components.

Connector Name / Designation	For Signal Connector
Manufacturer	JAE or Compatible
Type / Part Number	JAE HD1S040HA1 or Compatible
Mating Housing/Part Number	I-PEX 20453-040T-12 or Compatible

6.3.2 Pin Assignment

LVDS is a differential signal technology for LCD interface and high speed data transfer device.

PIN #	SIGNAL NAME	DESCRIPTION
1	NC	NC
2	VDD	+ 3.3V Power Supply
3	VDD	+ 3.3V Power Supply
4	VEDID	+ 3.3V EDID Power
5	N.C	No Connect.
6	CLKEDID	EDID Clock Input
7	DATAEDID	EDID Data Input
8	Odd_Rin0-	-LVDS Differential Data Input
9	Odd_Rin0+	+LVDS Differential Data Input
10	VSS	Power Ground
11	Odd_Rin1-	-LVDS Differential Data Input
12	Odd_Rin1+	+LVDS Differential Data Input
13	VSS	Power Ground
14	Odd_Rin2-	-LVDS Differential Data Input
15	Odd_Rin2+	+LVDS Differential Data Input
16	VSS	Power Ground
17	Odd_ClkIN-	-LVDS Differential Clock Input
18	Odd_ClkIN+	+LVDS Differential Clock Input
19	VSS	Ground
20	Even_Rin0-	-LVDS Differential Data Input
21	Even_Rin0+	+LVDS Differential Data Input



Product Specification

AU OPTRONICS CORPORATION

22	VSS	Power Ground
23	Even_Rin1-	-LVDS Differential Data Input
24	Even_Rin1+	+LVDS Differential Data Input
25	VSS	Power Ground
26	Even_Rin2-	-LVDS Differential Data Input
27	Even_Rin2+	+LVDS Differential Data Input
28	VSS	Power Ground
29	Even_ClkIN-	-LVDS Differential Clock Input
30	Even_ClkIN+	+LVDS Differential Clock Input
31	VLED_GND	LED_GND
32	VLED_GND	LED_GND
33	VLED_GND	LED_GND
34	NC	NC
35	S-PWM	
36	LED_EN	
37	NC	NC
38	VLED	LED_Positive (6~21)
39	VLED	LED_Positive(6~21)
40	VLED	LED_Positive(6~21)



Product Specification

AU OPTRONICS CORPORATION

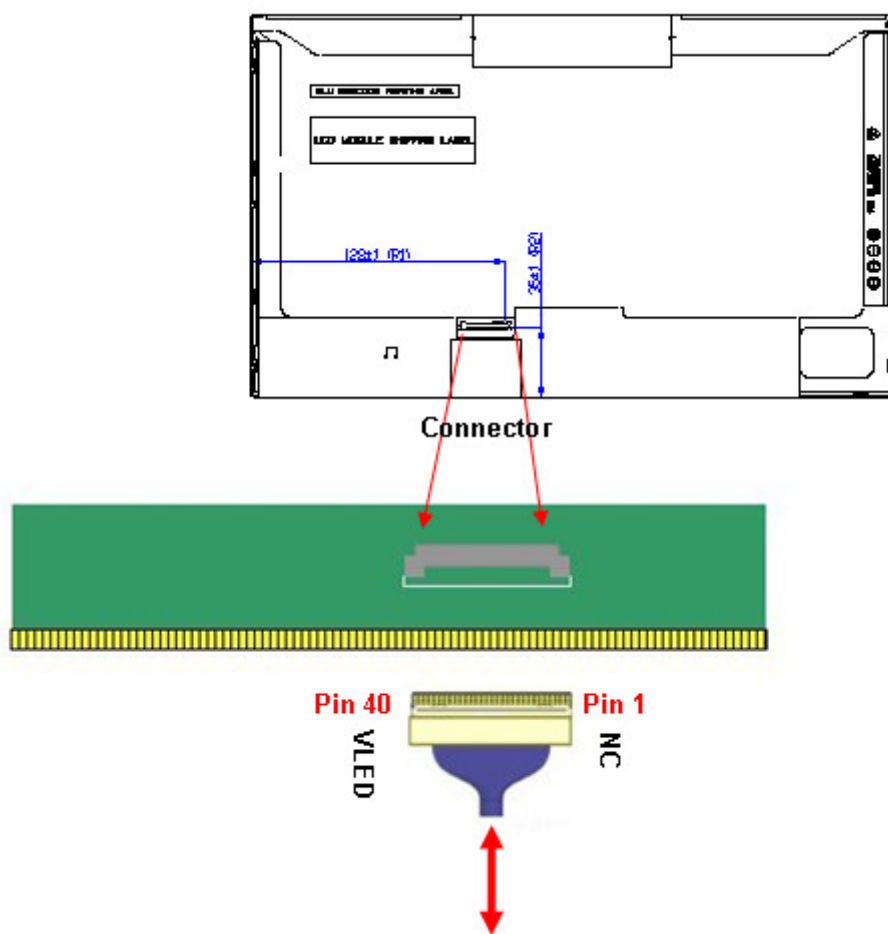

Note1: Input signals shall be low or High-impedance state when VDD is off.

6.4 Interface Timing

6.4.1 Timing Characteristics

Basically, interface timings should match the 1600x900 /60Hz manufacturing guide line timing.

Parameter	Symbol	Min.	Typ.	Max.	Unit	
Frame Rate	-		60		Hz	
Clock frequency	$1/T_{\text{Clock}}$		55		MHz	
Vertical Section	Period	T_V	908	912	2047	T_{Line}
	Active	T_{VD}	900			
	Blanking	T_{VB}	8	12	-	
Horizontal Section	Period	T_H	840	1006	2047	T_{Clock}
	Active	T_{HD}	800			
	Blanking	T_{HB}	40	206		

Note : DE mode only



Product Specification

AU OPTRONICS CORPORATION

6.4.2 Timing diagram

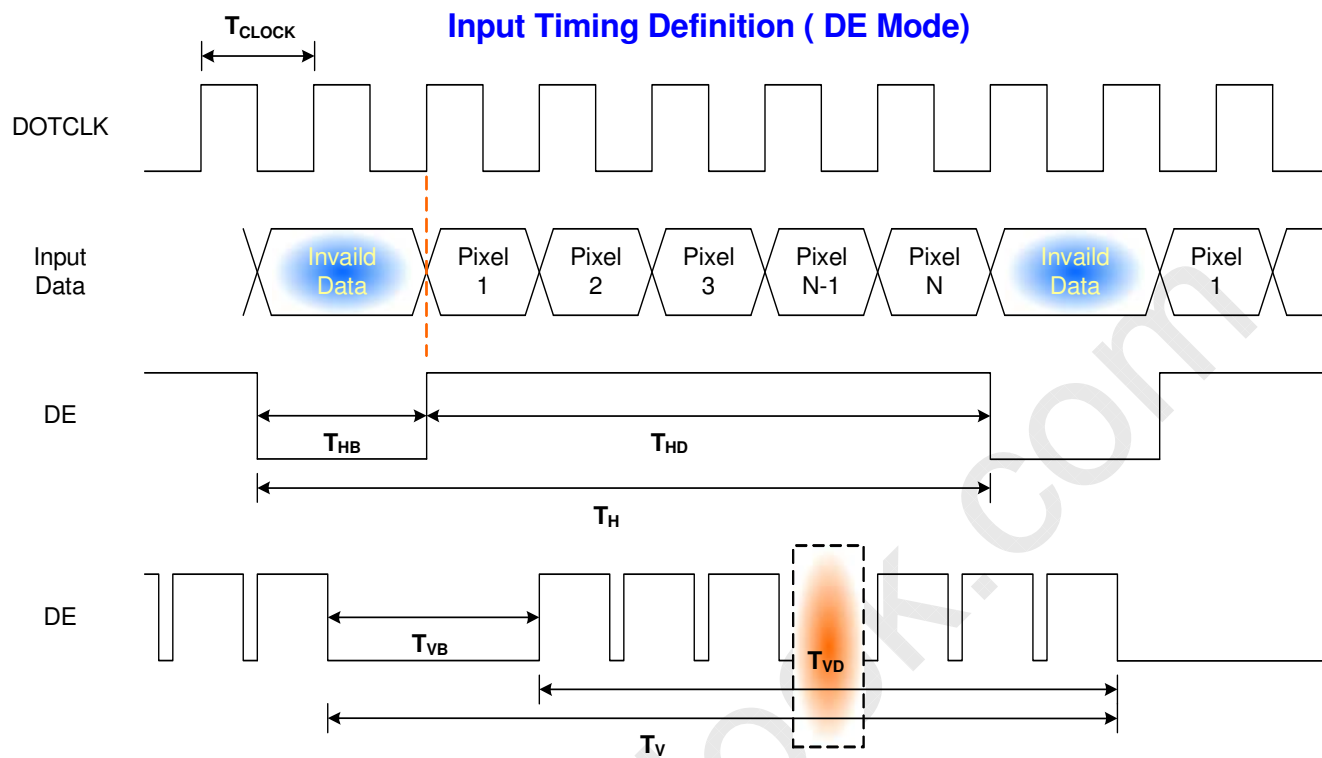



Product Specification

AU OPTRONICS CORPORATION

6.5 Power ON/OFF Sequence

VDD power on/off sequence is as follows. Interface signals are also shown in the chart. Signals from any system shall be Hi-Z state or low level when VDD is off

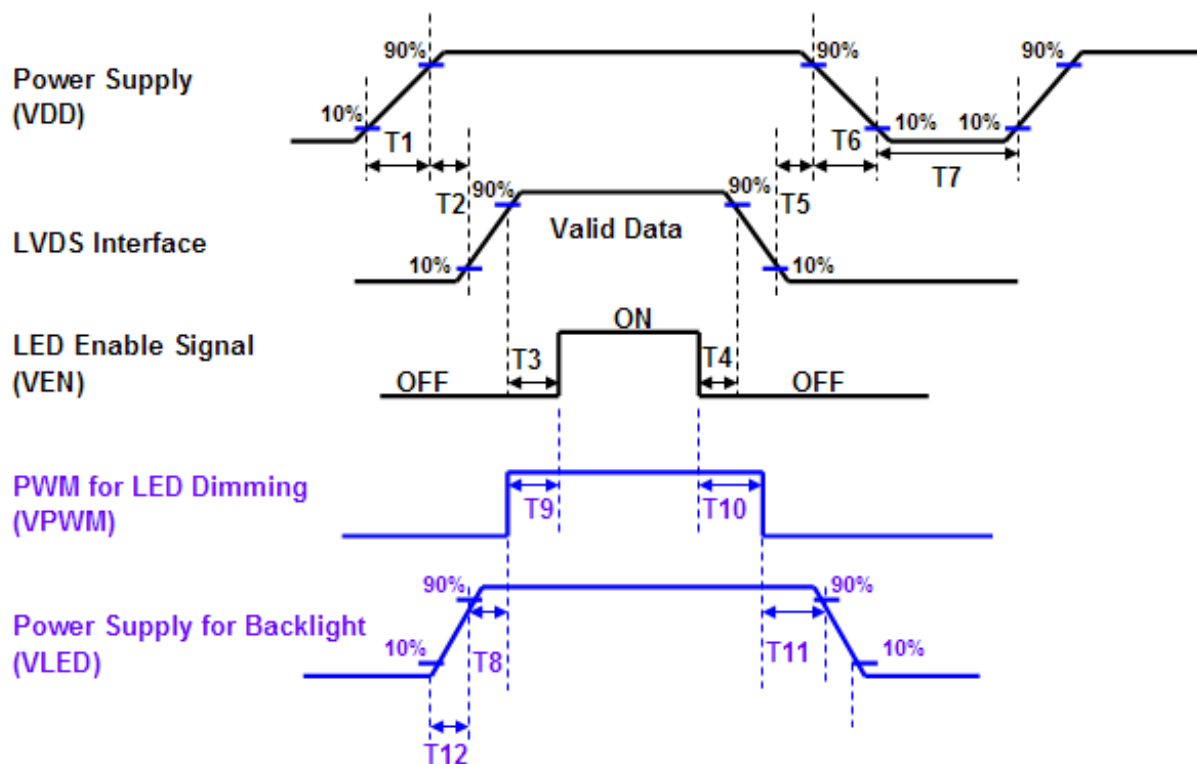

Power Sequence Timing			
Parameter	Value		Units
	Min.	Max.	
T1	0.5	10	ms
T2	0	50	
T3	250	-	
T4	200	-	
T5	0	50	
T6	0	10	
T7	500	-	
T8	10	-	
T9	10	180	
T10	10	180	
T11	10	-	
T12	0.5	10	



Product Specification

AU OPTRONICS CORPORATION

7. Panel Reliability Test

7.1 Vibration Test

Test Spec:

- Test method: Non-Operation
- Acceleration: 1.5 G
- Frequency: 10 - 500Hz Random
- Sweep: 30 Minutes each Axis (X, Y, Z)

7.2 Shock Test

Test Spec:

- Test method: Non-Operation
- Acceleration: 220 G , Half sine wave
- Active time: 2 ms
- Pulse: X,Y,Z .one time for each side

7.3 Reliability Test

Items	Required Condition	Note
Temperature Humidity Bias	Ta= 40°C, 90%RH, 300h	
High Temperature Operation	Ta= 50°C, Dry, 300h	
Low Temperature Operation	Ta= 0°C, 300h	
High Temperature Storage	Ta= 60°C, 35%RH, 300h	
Low Temperature Storage	Ta= -20°C, 50%RH, 250h	
Thermal Shock Test	Ta=-20°Cto 60°C, Duration at 30 min, 100 cycles	
ESD	Contact : ±8 KV Air : ±15 KV	Note 1

Note1: According to EN 61000-4-2 , ESD class B: Some performance degradation allowed. No data lost
. Self-recoverable. No hardware failures.

Remark: MTBF (Excluding the LED): 30,000 hours with a confidence level 90%

8. Mechanical Characteristics

8.1 LCM Outline Dimension

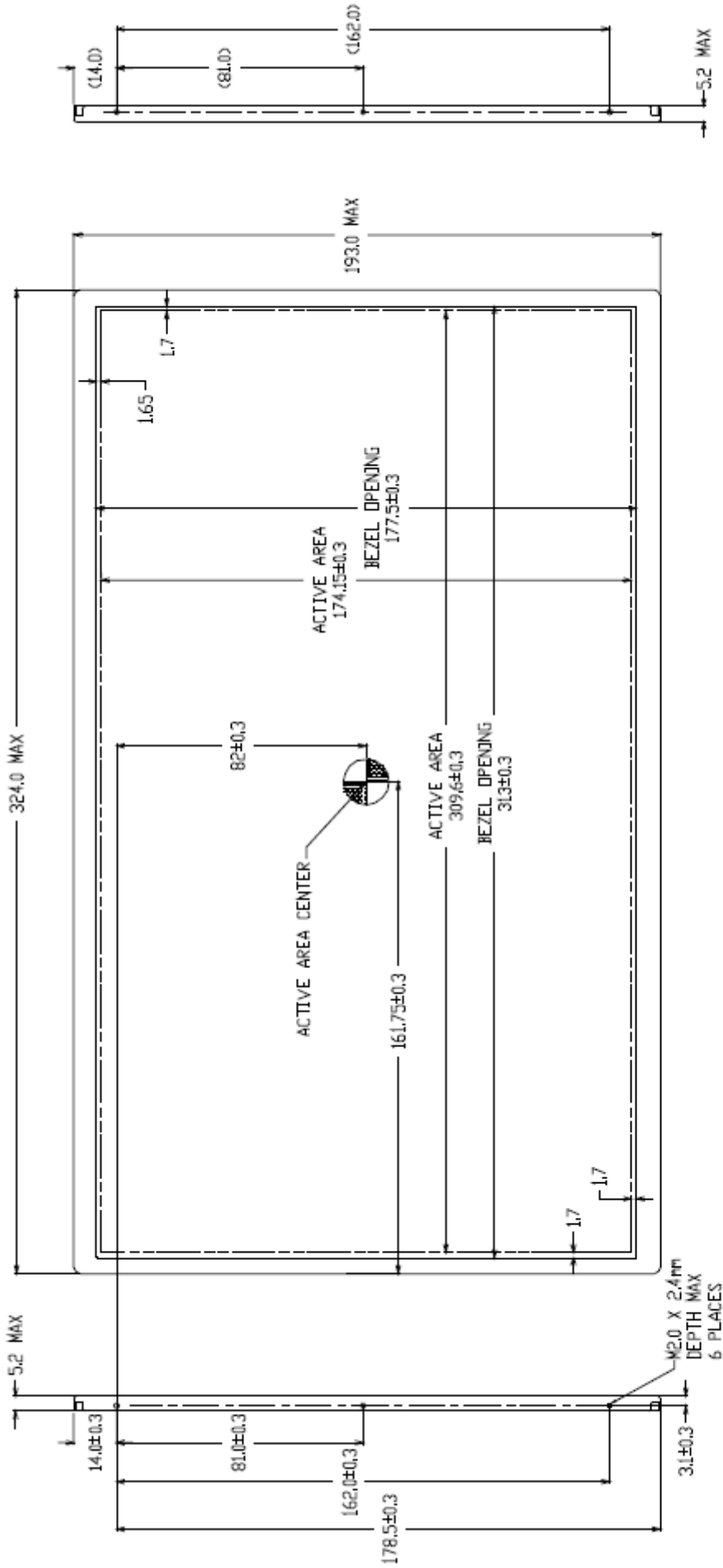

NOTE

1. 14.0" LCD module mechanical outline dimension
2. All dimension in mm
3. As viewed from front of LCD modules

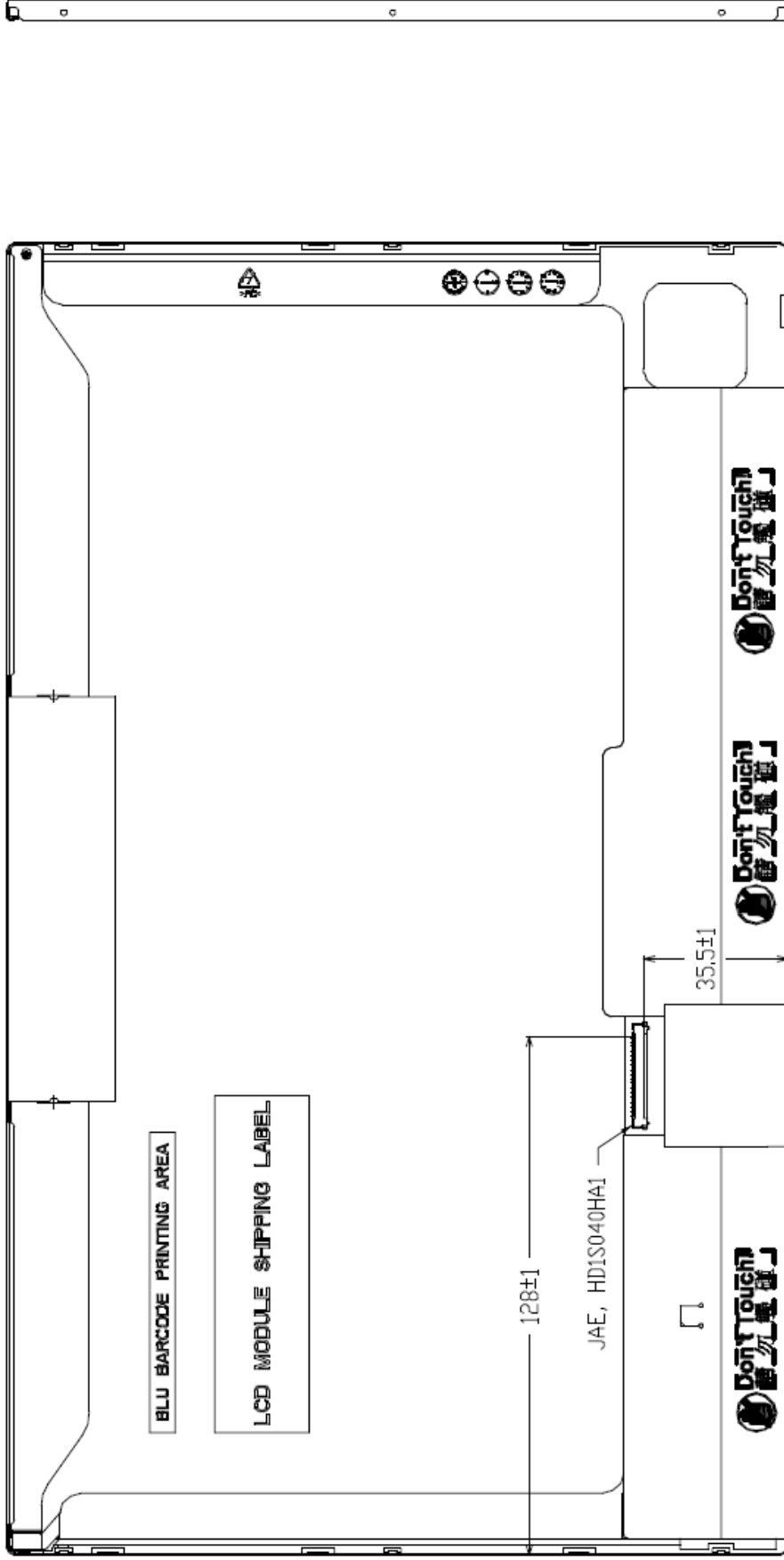

NOTE

1. 14.0" LCD module mechanical outline dimension
2. All dimension in mm
3. As viewed from back of LCD modules

Note: Prevention IC damage, IC positions not allowed any overlap over these areas

9. Shipping and Package

9.1 Shipping /Carton Label Format

 *XXXXXXXXXXXX-XXXXX	Manufactured XX/XX Model No: B140RW03 V0 AU Optronics Made in China (S01)	   
	H/W: 0A F/W:1	

AU Optronics	QTY : 25		
MODEL NO :	B140RW03V0		
PART NO :	97.14B43.000		
CUSTOMER NO :			
CARTON NO :			
Made in China	*ZM100-0652300205*		

9.2 Carton Package

The outside dimension of carton is 455 (L)mm x 380 (W)mm x 355 (H)mm

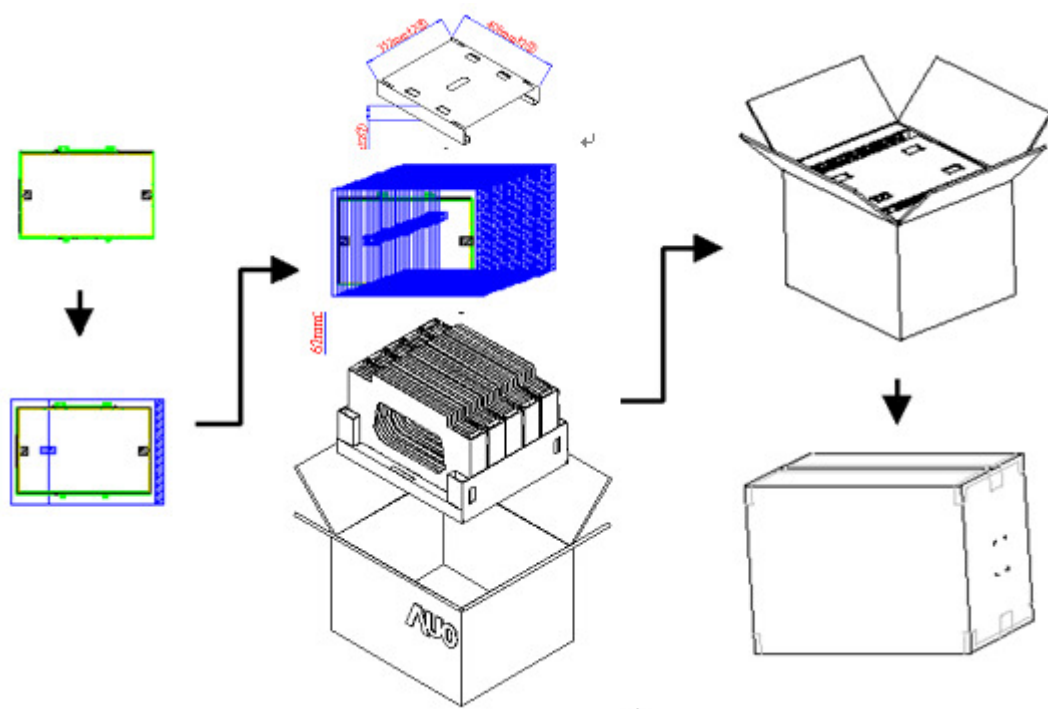

9.3 Shipping Package of Palletizing Sequence

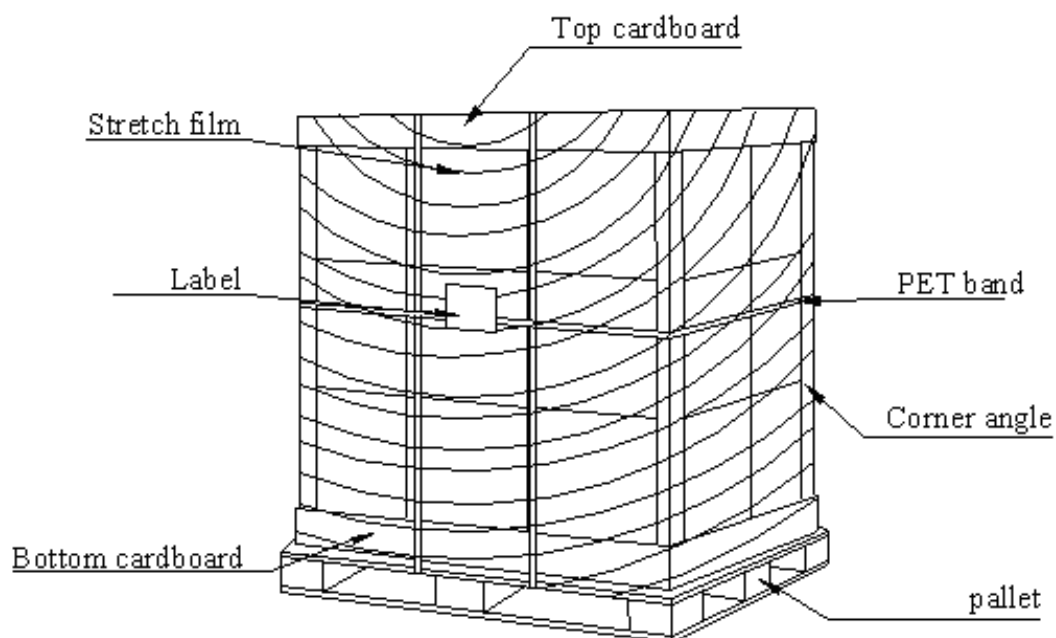

10. Appendix: EDID Description

TBD

www.panelook.com