





## Contents

<b>1. Handling Precautions .....</b>	<b>4</b>
<b>2. General Description .....</b>	<b>5</b>
2.1 General Specification.....	5
2.2 Optical Characteristics .....	6
<b>3. Functional Block Diagram .....</b>	<b>11</b>
<b>4. Absolute Maximum Ratings .....</b>	<b>12</b>
4.1 Absolute Ratings of TFT LCD Module .....	12
4.2 Absolute Ratings of Environment.....	12
<b>5. Electrical Characteristics .....</b>	<b>13</b>
5.1 TFT LCD Module .....	13
5.2 Backlight Unit.....	16
<b>6. Signal Interface Characteristic .....</b>	<b>17</b>
6.1 Pixel Format Image.....	17
6.2 Integration Interface Requirement .....	18
6.3 Interface Timing.....	21
6.4 Power ON/OFF Sequence.....	22
<b>7. Panel Reliability Test.....</b>	<b>25</b>
7.1 Vibration Test.....	25
7.2 Shock Test.....	25
7.3 Reliability Test.....	25
<b>8. Mechanical Characteristics .....</b>	<b>26</b>
8.1 LCM Outline Dimension .....	26
<b>9. Shipping and Package .....</b>	<b>28</b>
9.1 Shipping Label Format .....	28
9.2 Carton Label Format.....	28
9.3 Carton Package .....	28
9.4 Shipping Package of Palletizing Sequence.....	29
<b>10. Appendix: EDID Description .....</b>	<b>30</b>



# Product Specification

AU OPTRONICS CORPORATION

## Record of Revision

Version and Date	Page	Old description	New Description	Remark
0.1 2014/02/06	All	First Edition for Customer		

www.yslcd.com.tw

## 1. Handling Precautions

- 1) Since front polarizer is easily damaged, pay attention not to scratch it.
- 2) Be sure to turn off power supply when inserting or disconnecting from input connector.
- 3) Wipe off water drop immediately. Long contact with water may cause discoloration or spots.
- 4) When the panel surface is soiled, wipe it with absorbent cotton or other soft cloth.
- 5) Since the panel is made of glass, it may break or crack if dropped or bumped on hard surface.
- 6) Since CMOS LSI is used in this module, take care of static electricity and insure human earth when handling.
- 7) Do not open nor modify the Module Assembly.
- 8) Do not press the reflector sheet at the back of the module to any directions.
- 9) At the insertion or removal of the Signal Interface Connector, be sure not to rotate nor tilt the Interface Connector of the TFT Module.
- 11) After installation of the TFT Module into an enclosure (Notebook PC Bezel, for example), do not twist nor bend the TFT Module even momentary. At designing the enclosure, it should be taken into consideration that no bending/twisting forces are applied to the TFT Module from outside. Otherwise the TFT Module may be damaged.
- 12) Small amount of materials having no flammability grade is used in the LCD module. The LCD module should be supplied by power complied with requirements of Limited Power Source (IEC60950 or UL1950), or be applied exemption.
- 13) Disconnecting power supply before handling LCD modules, it can prevent electric shock, DO NOT TOUCH the electrode parts, cables, connectors and LED circuit part of TFT module that a LED light bar build in as a light source of back light unit. It can prevent electrostatic breakdown.

## 2. General Description

B140XTN06.2 is a Color Active Matrix Liquid Crystal Display composed of a TFT LCD panel, a driver circuit, and LED backlight system. The screen format is intended to support the 16:9 HD, 1366(H) x768(V) screen and 262k colors (RGB 6-bits data driver) with LED backlight driving circuit. All input signals are eDP(Embedded DisplayPort) interface compatible.

B140XTN06.2 is designed for a display unit of notebook style personal computer and industrial machine.

### 2.1 General Specification

The following items are characteristics summary on the table at 25 °C condition:

Items	Unit	Specifications			
Screen Diagonal	[mm]	354.95			
Active Area	[mm]	309.4 x 173.95			
Pixels H x V		1366x3(RGB) x 768			
Pixel Pitch	[mm]	0.2265 x 0.2265			
Pixel Format		R.G.B. Vertical Stripe			
Display Mode		A Normally White			
White Luminance (I <sub>LED</sub> =23mA) (Note: I <sub>LED</sub> is LED current)	[cd/m <sup>2</sup> ]	220 typ. (5 points average) 187 min. (5 points average)			
Luminance Uniformity		1.25 max. (5 points)			
Contrast Ratio		500 typ			
Response Time	[ms]	8 typ / 16 Max			
Nominal Input Voltage VDD	[Volt]	+3.3 typ.			
Power Consumption	[Watt]	TBD max. (Include Logic and Blu power)			
Weight	[Grams]	TBD max.			
Physical Size Include bracket	[mm]		Min.	Typ.	Max.
		Length	325.93	326.18	326.43
		Width	204.60	205.10	205.60
		Thickness	-	-	3.0 (Panel Side) 3.0 (PCBA)
Electrical Interface		1 Lane eDP 1.2			
Glass Thickness	[mm]	0.4			
Surface Treatment		Glare, Hardness 3H			
Support Color		262K colors ( RGB 6-bit )			



# Product Specification

AU OPTRONICS CORPORATION

Temperature Range Operating Storage (Non-Operating)	[°C] [°C]	0 to +50 -20 to +60
RoHS Compliance		RoHS Compliance

## 2.2 Optical Characteristics

The optical characteristics are measured under stable conditions at 25°C (Room Temperature) :

Item	Symbol	Conditions	Min.	Typ.	Max.	Note	
White Luminance I <sub>LED</sub> =20mA		5 points average	187	220	-	cd/m <sup>2</sup> 1, 4, 5.	
Viewing Angle	$\theta_R$	Horizontal (Right) CR = 10 (Left)	40	45	-	degree 4, 9	
	$\theta_L$		40	45	-		
	$\phi_H$	Vertical (Upper) CR = 10 (Lower)	10	15	-		
	$\phi_L$		30	35	-		
Luminance Uniformity	$\delta_{5P}$	5 Points	-	-	1.25	1, 3, 4	
Luminance Uniformity	$\delta_{13P}$	13 Points	-	-	1.60	2, 3, 4	
Contrast Ratio	CR		400	500	-	4, 6	
Cross talk	%				4	4, 7	
Response Time	T <sub>RT</sub>	Rising + Falling	-	8	16	msec 4, 8	
Color / Chromaticity Coordinates	Red	R <sub>x</sub>	CIE 1931	TBD	TBD	TBD	4
		R <sub>y</sub>		TBD	TBD	TBD	
	Green	G <sub>x</sub>		TBD	TBD	TBD	
		G <sub>y</sub>		TBD	TBD	TBD	
	Blue	B <sub>x</sub>		TBD	TBD	TBD	
		B <sub>y</sub>		TBD	TBD	TBD	
	White	W <sub>x</sub>		0.283	0.313	0.343	
		W <sub>y</sub>		0.299	0.329	0.359	
	NTSC	%			-	45	

**Note 1:** 5 points position (Ref: Active area)

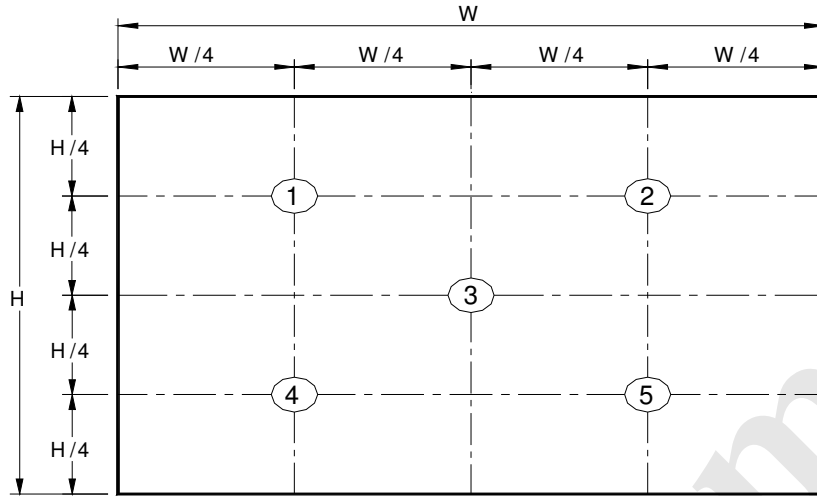

**Note 2:** 13 points position (Ref: Active area)

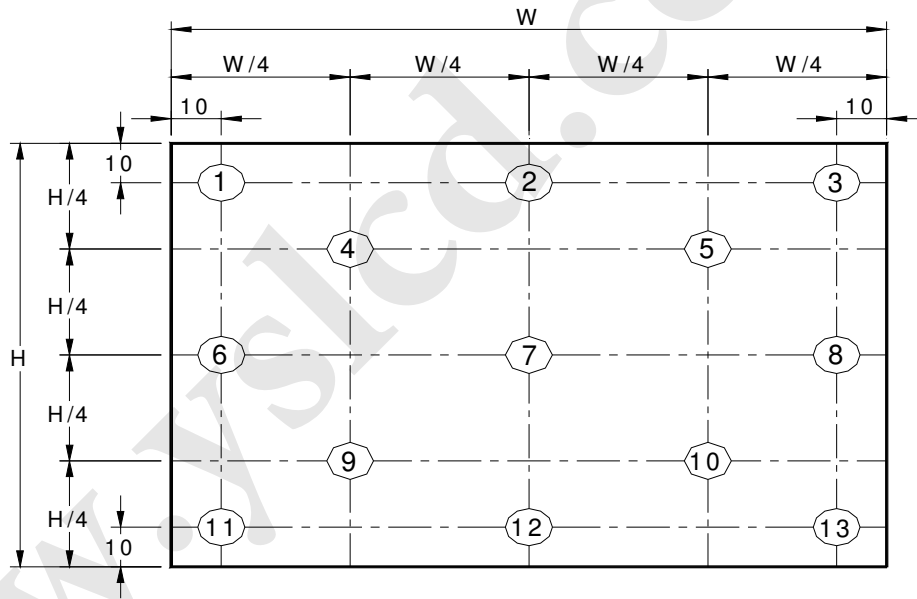

**Note 3:** The luminance uniformity of 5 or 13 points is defined by dividing the maximum luminance values by the minimum test point luminance

$$\delta_{w5} = \frac{\text{Maximum Brightness of five points}}{\text{Minimum Brightness of five points}}$$

$$\delta_{w13} = \frac{\text{Maximum Brightness of thirteen points}}{\text{Minimum Brightness of thirteen points}}$$

**Note 4:** Measurement method

The LCD module should be stabilized at given temperature for 30 minutes to avoid abrupt temperature change during measuring. In order to stabilize the luminance, the measurement should be executed after lighting Backlight for 30 minutes in a stable, windless and dark room, and it should be measured in the center of screen.

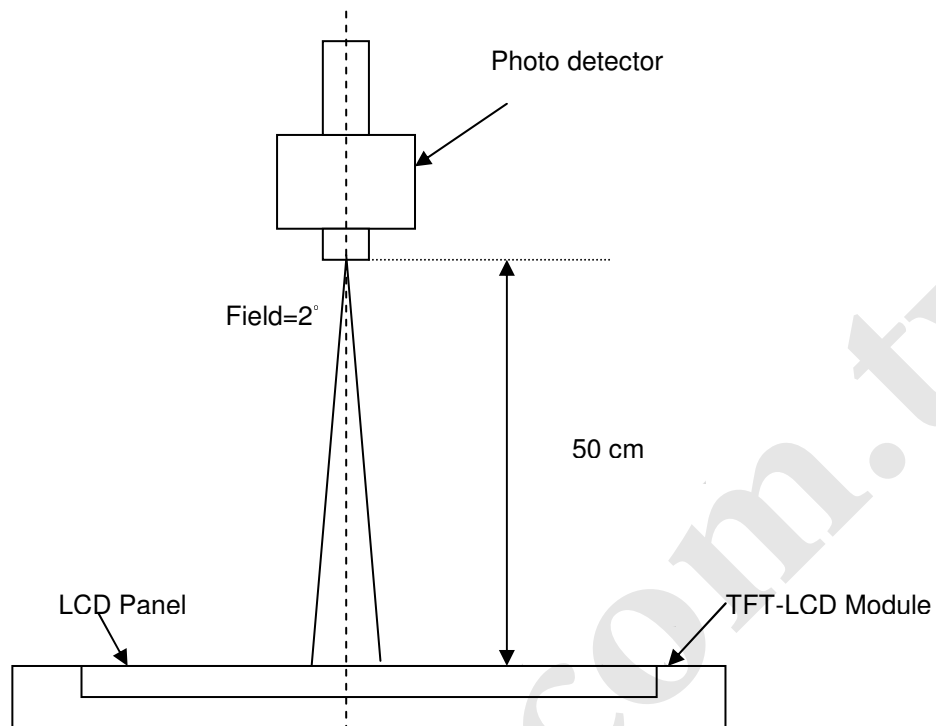

**Note 5 :** Definition of Average Luminance of White ( $L_w$ )

Measure the luminance of gray level 63 at 5 points ·  $Y_L = [L(1) + L(2) + L(3) + L(4) + L(5)] / 5$

$L(x)$  is corresponding to the luminance of the point X at Figure in Note (1).

**Note 6 :** Definition of contrast ratio:

Contrast ratio is calculated with the following formula.

$$\text{Contrast ratio (CR)} = \frac{\text{Brightness on the "White" state}}{\text{Brightness on the "Black" state}}$$

**Note 7** Definition of Cross Talk (CT)

$$\text{CT} = |Y_B - Y_A| / Y_A \times 100 (\%)$$

Where

$Y_A$  = Luminance of measured location without gray level 0 pattern (cd/m<sup>2</sup>)

$Y_B$  = Luminance of measured location with gray level 0 pattern (cd/m<sup>2</sup>)



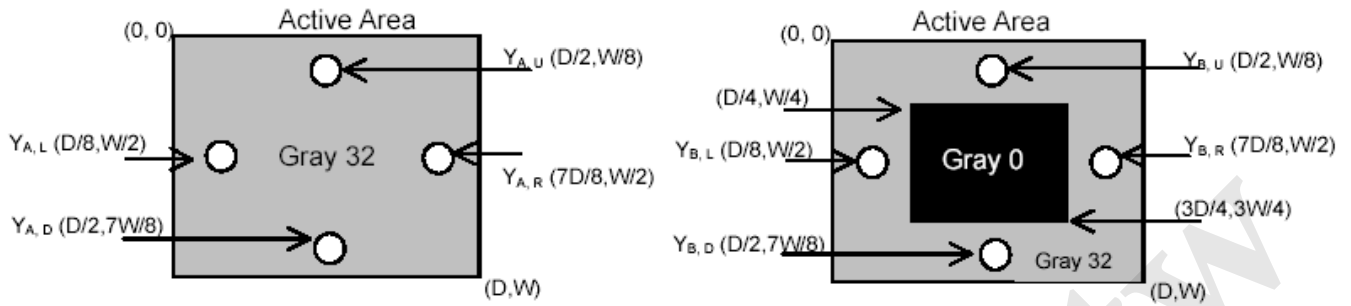

**Note 8:** Definition of response time:

The output signals of BM-7 or equivalent are measured when the input signals are changed from "Black" to "White" (falling time) and from "White" to "Black" (rising time), respectively. The response time interval between the 10% and 90% of amplitudes. Refer to figure as below.

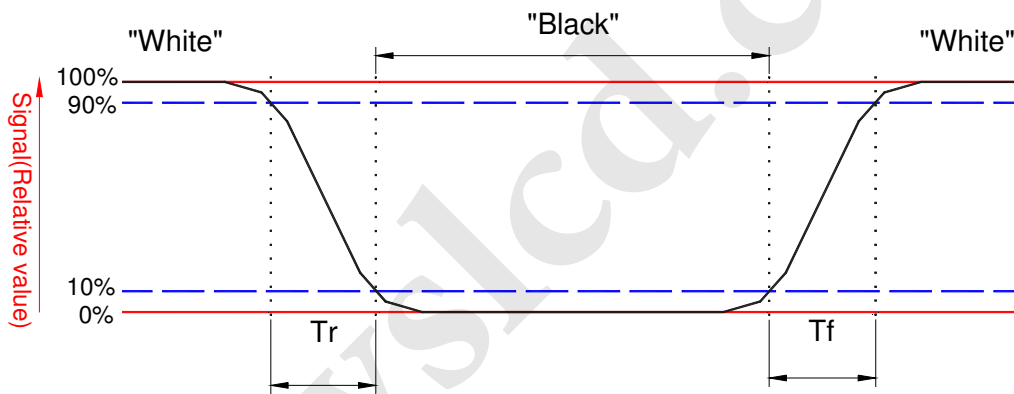

**Note 9.** Definition of viewing angle

Viewing angle is the measurement of contrast ratio  $\geq 10$ , at the screen center, over a  $180^\circ$  horizontal and  $180^\circ$  vertical range (off-normal viewing angles). The  $180^\circ$  viewing angle range is broken down as follows;  $90^\circ$  ( $\theta$ ) horizontal left and right and  $90^\circ$  ( $\Phi$ ) vertical, high (up) and low (down). The measurement direction is typically perpendicular to the display surface with the screen rotated about its center to develop the desired measurement viewing angle.

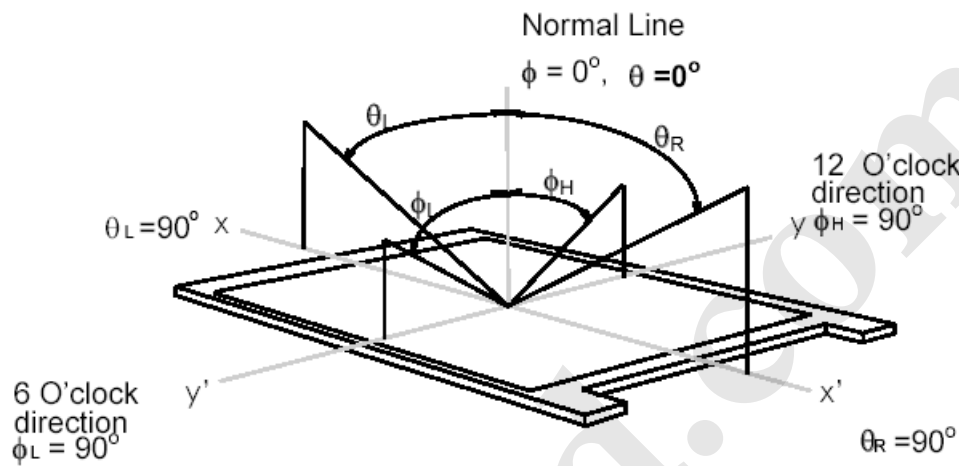

### 3. Functional Block Diagram

The following diagram shows the functional block of the 14 inches wide Color TFT/LCD 40 Pin

[www.yslcd.com.tw](http://www.yslcd.com.tw)

## 4. Absolute Maximum Ratings

An absolute maximum rating of the module is as following:

### 4.1 Absolute Ratings of TFT LCD Module

Item	Symbol	Min	Max	Unit	Conditions
Logic/LCD Drive Voltage	Vin	TBD	TBD	[Volt]	Note 1,2

### 4.2 Absolute Ratings of Environment

Item	Symbol	Min	Max	Unit	Conditions
Operating Temperature	TOP	0	+50	[°C]	Note 4
Operation Humidity	HOP	5	95	[%RH]	Note 4
Storage Temperature	TST	-20	+60	[°C]	Note 4
Storage Humidity	HST	5	95	[%RH]	Note 4

Note 1: At Ta (25°C )

Note 2: Permanent damage to the device may occur if exceed maximum values

Note 3: LED specification refer to section 5.2

Note 4: For quality performance, please refer to AUO IIS (Incoming Inspection Standard).

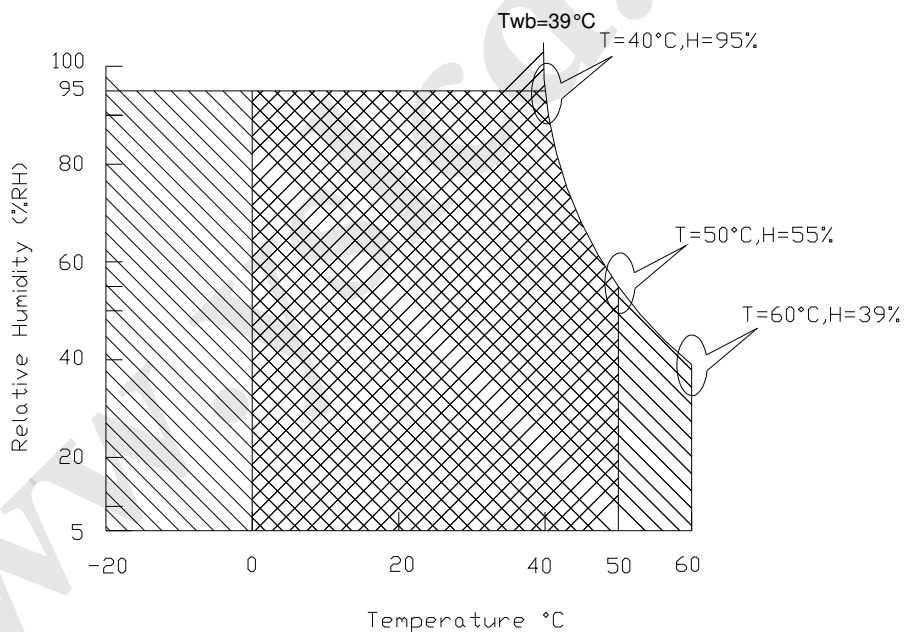

Operating Range 

Storage Range  + 

## 5. Electrical Characteristics

### 5.1 TFT LCD Module

#### 5.1.1 Power Specification

Input power specifications are as follows;

The power specification are measured under 25°C and frame frequency under 60Hz

Symble	Parameter	Min	Typ	Max	Units	Note
VDD	Logic/LCD Drive Voltage	3.0	3.3	3.6	[Volt]	
PDD	VDD Power	-	0.6	--	[Watt]	Note 1
IDD	IDD Current	-	0.2	--	[mA]	Note 1
IRush	Inrush Current	-	-	1500	[mA]	Note 2
VDDrp	Allowable Logic/LCD Drive Ripple Voltage	-	-	100	[mV] p-p	

Note 1 : Maximum Measurement Condition : Black Pattern at 3.3V driving voltage. ( $P_{max}=V_{3.3} \times I_{black}$ )

Typical Measurement Condition : Mosaic Pattern

Note 2 : Measure Condition

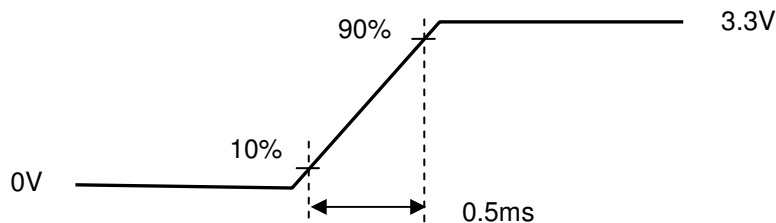
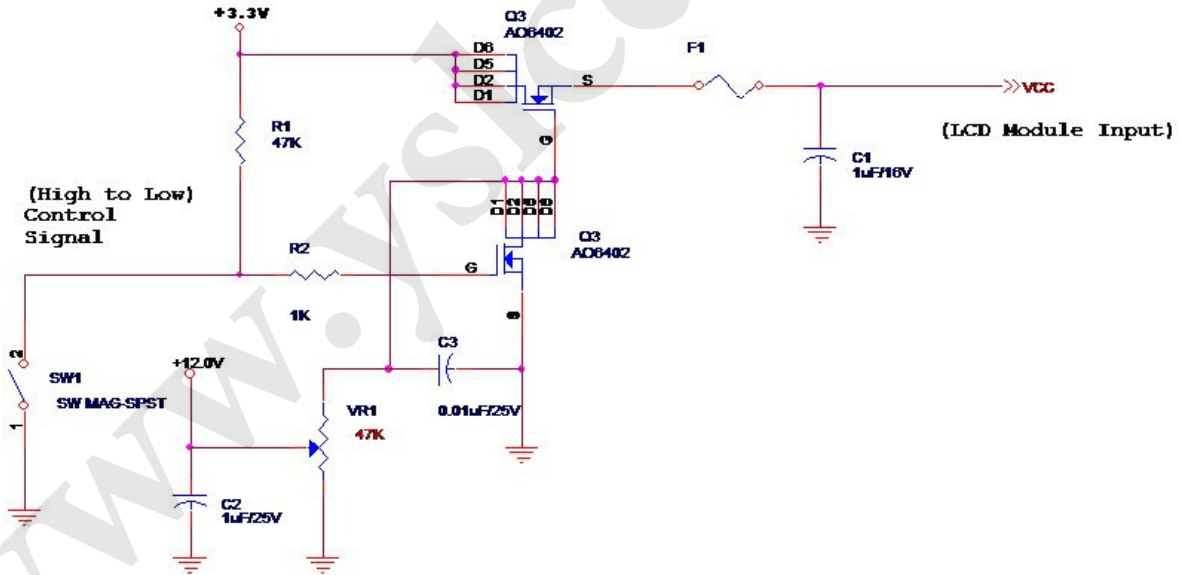

Vin rising time

## 5.1.2 Signal Electrical Characteristics

Input signals shall be low or High-impedance state when VDD is off.

Signal electrical characteristics are as follows;

### Display Port main link signal:

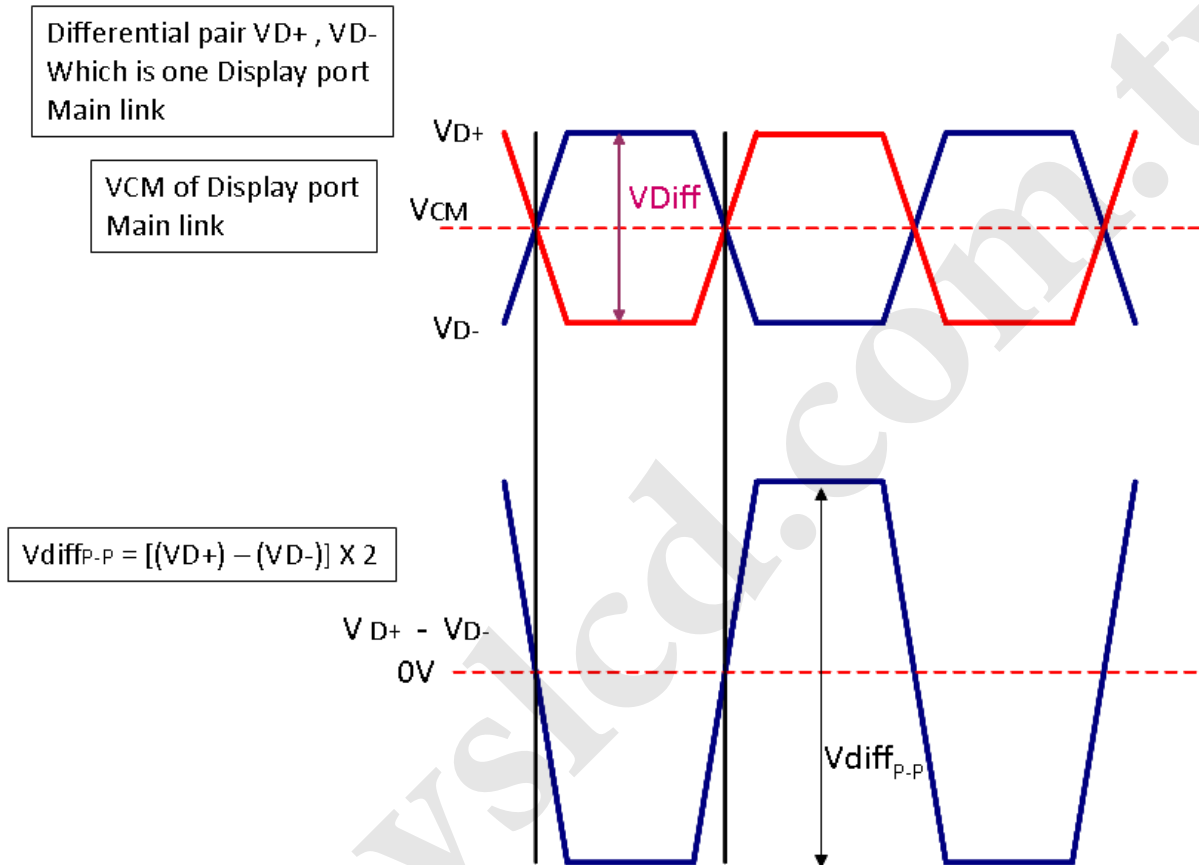

Display port main link					
		Min	Typ	Max	unit
VCM	RX input DC Common Mode Voltage		GND		V
VDiff <sub>P-P</sub>	Peak-to-peak Voltage at a receiving Device	100		1320	mV

Fallow as VESA display port standard V1.1a

## Display Port AUX\_CH signal:

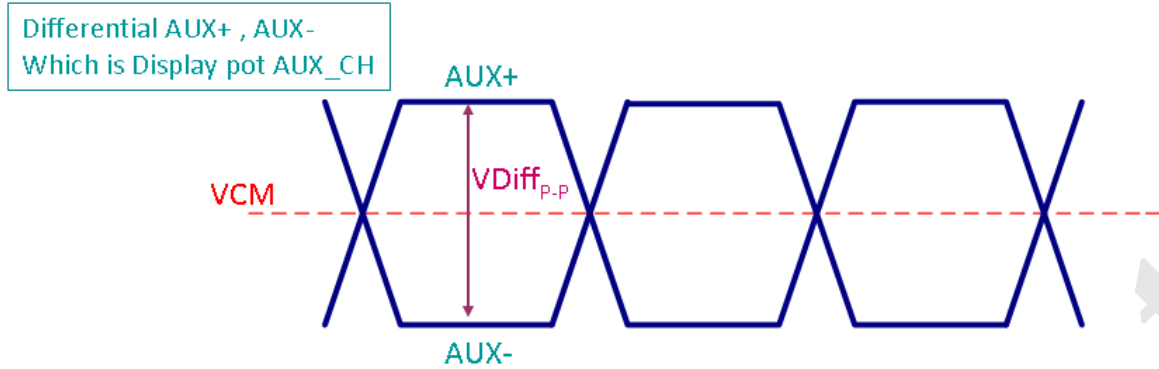

Display port AUX_CH					
		Min	Typ	Max	unit
VCM	AUX DC Common Mode Voltage		GND/0.15		V
VDiff <sub>p-p</sub>	AUX Peak-to-peak Voltage at a receiving Device	400	600	800	V

Fallow as VESA display port standard V1.1a.

## Display Port VHPD signal:

Display port VHPD					
		Min	Typ	Max	unit
VHPD	HPD Voltage	0	2.5	2.5	V

Fallow as VESA display port standard V1.1a.

## 5.2 Backlight Unit

### 5.2.1 LED characteristics

Parameter	Symbol	Min	Typ	Max	Units	Condition
Backlight Power Consumption	PLED	-	2.0	--	[Watt]	(Ta=25°C), Note 1 Vin =12V
LED Life-Time	N/A	15,000	-	-	Hour	(Ta=25°C), Note 2 IF=23 mA

**Note 1:** Calculator value for reference  $P_{LED} = VF$  (Normal Distribution) \*  $IF$  (Normal Distribution) / Efficiency

**Note 2:** The LED life-time define as the estimated time to 50% degradation of initial luminous.

### 5.2.2 Backlight input signal characteristics

Parameter	Symbol	Min	Typ	Max	Units	Remark
LED Power Supply	VLED	6	12	21	[Volt]	Define as Connector Interface (Ta=25°C)
LED Enable Input High Level	VLED_EN	1.8	--	--	[Volt]	
LED Enable Input Low Level		--	--	0.5	[Volt]	
PWM Logic Input High Level	VPWM_EN	1.8	--	--	[Volt]	
PWM Logic Input Low Level		--	--	0.5	[Volt]	
PWM Input Frequency	FPWM	200	--	10000	Hz	
PWM Duty Ratio	Duty	1	--	100	%	

**Note 1 :** Recommend system pull up/down resistor no bigger than 10kohm





## 6.2 Integration Interface Requirement

### 6.2.1 Connector Description

Physical interface is described as for the connector on module.

These connectors are capable of accommodating the following signals and will be following components.

Connector Name / Designation	For Signal Connector
Manufacturer	TBD
Type / Part Number	TBD
Mating Housing/Part Number	TBD

### 6.2.2 Pin Assignment (1 Lane)

eDP lane is a differential signal technology for LCD interface and high speed data transfer device.

PIN NO	Symbol	Function
1	NC	No Connect (Reserved for DCR)
2	H_GND	High Speed Ground
3	NC	No connect
4	NC	No connect
5	H_GND	High Speed Ground
6	Lane0_N	Comp Signal Link Lane 0
7	Lane0_P	True Signal Link Lane 0
8	H_GND	High Speed Ground
9	AUX_CH_P	True Signal Auxiliary Ch.
10	AUX_CH_N	Comp Signal Auxiliary Ch.
11	H_GND	High Speed Ground
12	LCD_VCC	LCD logic and driver power
13	LCD_VCC	LCD logic and driver power
14	LCD_Self_Test	LCD Panel Self Test Enable
15	LCD_GND	LCD logic and driver ground
16	LCD_GND	LCD logic and driver ground
17	HPD	HPD signal pin
18	BL_GND	Backlight ground
19	BL_GND	Backlight ground
20	BL_GND	Backlight ground

21	BL_GND	Backlight ground
22	BL_Enable	Backlight On / Off
23	BL_PWM_DIM	System PWM signal Input
24	NC	No connect (Reverse for AUO TEST only)
25	NC	No connect (Reverse for AUO TEST only)
26	BL_PWR	Backlight power (6V~21V)
27	BL_PWR	Backlight power (6V~21V)
28	BL_PWR	Backlight power (6V~21V)
29	BL_PWR	Backlight power (6V~21V)
30	NC	No Connect (Reserved for CM)
31	TP_D-	USB Data- for Touch
32	TP_D+	USB Data+ for Touch
33	GND	Ground-Shield
34	VTSP	Touch panel power supply (3.3V)
35	VTSP	Touch panel power supply (3.3V)
36	NC/TP_EN	No Connection (Reserve for Touch function enable)
37	TP_CLK	I2C Clock for Touch (NC for USB input)
38	TP_Data	I2C Clock for Touch (NC for USB input)
39	INT	Interrupt for Touch (NC for USB input)
40	RST	Reset for Touch (NC for USB input)

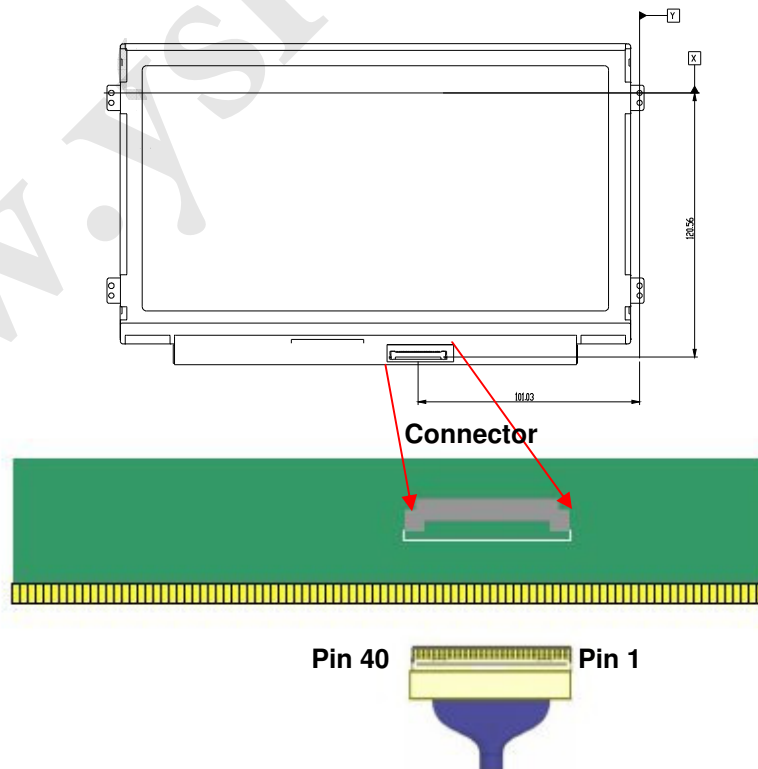

**Note1:** Start from right side.

**Note2:** Input signals shall be low or High-impedance state when VDD is off.  
Internal circuit of **eDP inputs** are as following.

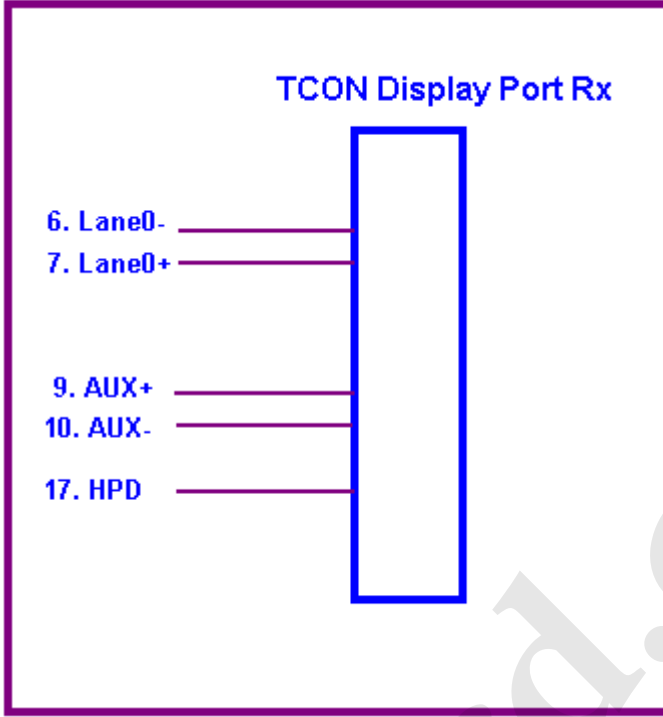

## 6.3 Interface Timing

### 6.3.1 Timing Characteristics

Basically, interface timings should match the 1366x768 /60Hz manufacturing guide line timing.

Parameter	Symbol	Min.	Typ.	Max.	Unit	
Frame Rate	-	-	60	-	Hz	
Clock frequency	$1/T_{\text{Clock}}$	66.9	72	80	MHz	
Vertical Section	Period	788	824	768+A	768+A	$T_{\text{Line}}$
	Active	$T_{\text{VD}}$	768			
	Blanking	$T_{\text{VB}}$	20	56	A	
Horizontal Section	Period	$T_{\text{H}}$	1416	1456	1366+B	$T_{\text{Clock}}$
	Active	$T_{\text{HD}}$	1366			
	Blanking	$T_{\text{HB}}$	50	90	B	

**Note 1 :** The above is as optimized setting

**Note 2 :** The maximum clock frequency =  $(1366+B) \cdot (768+A) \cdot 60 < 80\text{MHz}$

## 6.4 Power ON/OFF Sequence

Display Port panel power sequence:

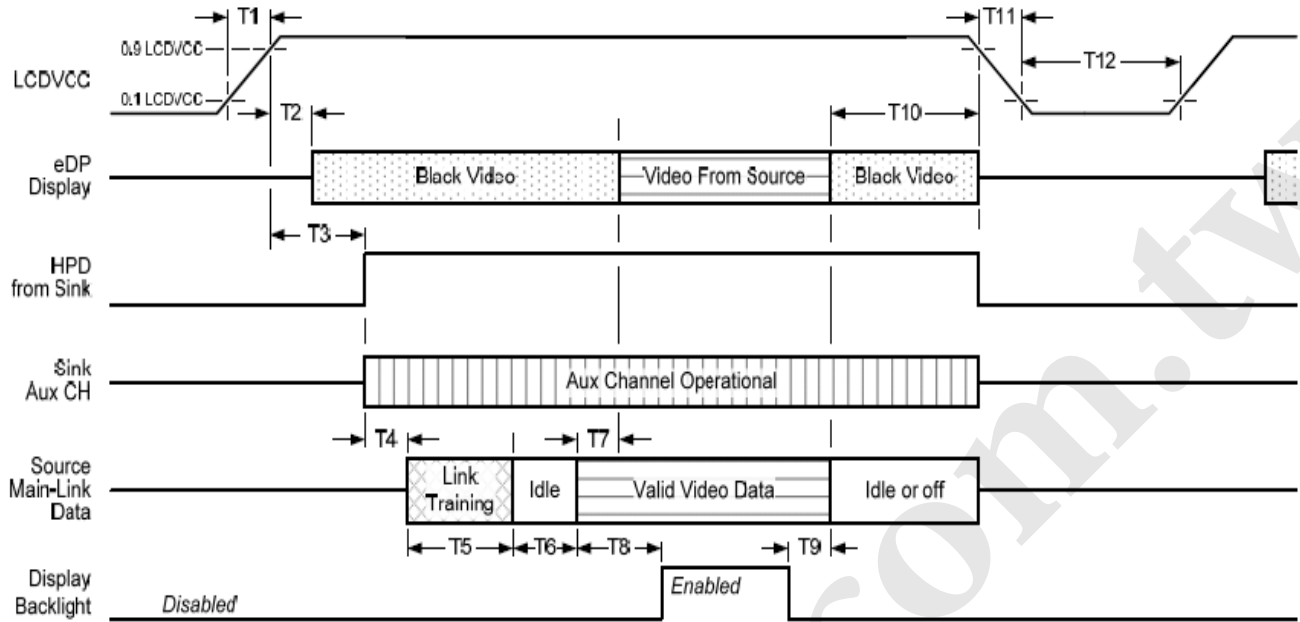

Display port interface power up/down sequence, normal system operation

Display Port AUX\_CH transaction only:

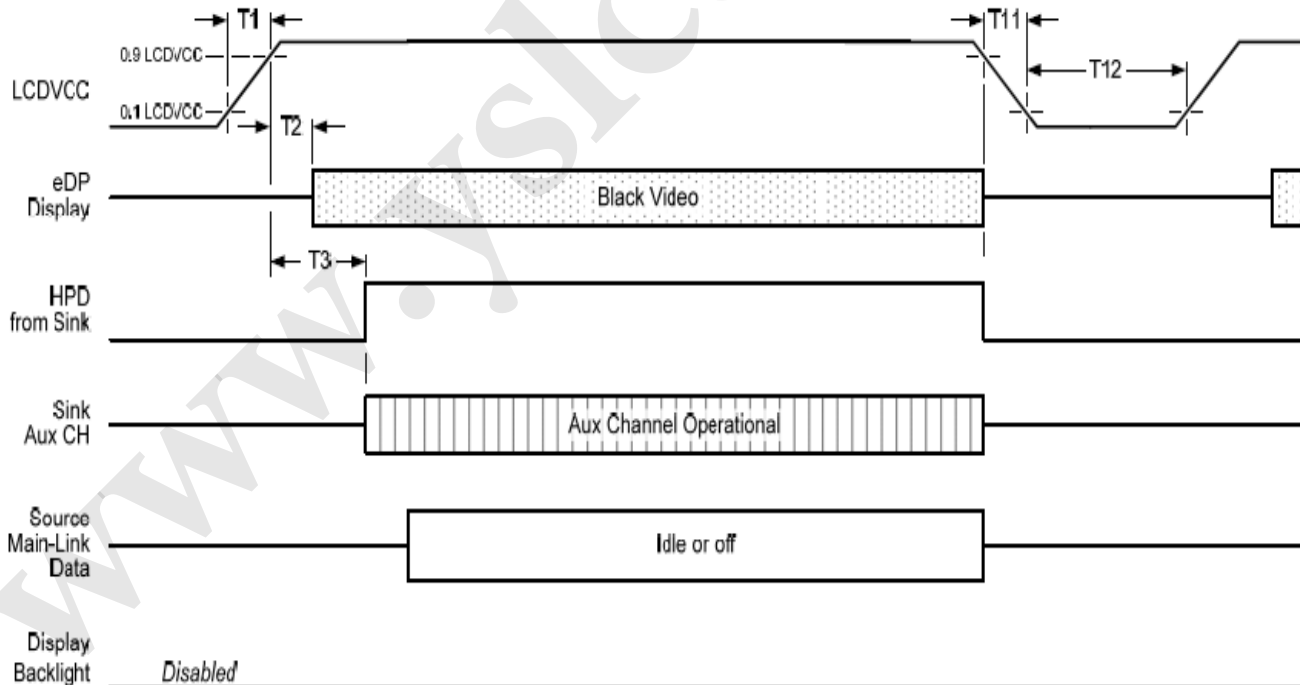

Display port interface power up/down sequence, AUX\_CH transaction only



# Product Specification

AU OPTRONICS CORPORATION

## Display Port panel power sequence timing parameter:

Timing parameter	Description	Reqd. by	Limits			Notes
			Min.	Typ.	Max.	
T1	power rail rise time, 10% to 90%	source	0.5ms		10ms	
T2	delay from LCDVDD to black video generation	sink	0ms		200ms	prevents display noise until valid video data is received from the source
T3	delay from LCDVDD to HPD high	sink	0ms		200ms	sink AUX_CH must be operational upon HPD high.
T4	delay from HPD high to link training initialization	source				allows for source to read link capability and initialize.
T5	link training duration	source				dependant on source link to read training protocol.
T6	link idle	source				Min accounts for required BS-Idle pattern. Max allows for source frame synchronization.
T7	delay from valid video data from source to video on display	sink	0ms		50ms	max allows sink validate video data and timing.
T8	delay from valid video data from source to backlight enable	source				source must assure display video is stable.
T9	delay from backlight disable to end of valid video data	source				source must assure backlight is no longer illuminated.
T10	delay from end of valid video data from source to power off	source	0ms		500ms	
T11	power rail fall time, 90% to 10%	source			10ms	
T12	power off time	source	500ms			

**Note1:** The sink must include the ability to generate black video autonomously. The sink must automatically enable black video under the following conditions:

- upon LCDVDD power on (with in T2 max)-when the "Novideostream\_Flag" (VB-ID Bit 3) is received from the source (at the end of T9).

- when no main link data, or invalid video data, is received from the source. Black video must be displayed within 64ms (typ) from the start of either condition. Video data can be deemed invalid based on MSA and timing information, for example.

**Note 2:** The sink may implement the ability to disable the black video function, as described in Note 1, above, for system development and debugging purpose.

**Note 3:** The sink must support AUX\_CH polling by the source immediately following LCDVDD power on without causing damage to the sink device (the source can re-try if the sink is not ready). The sink must be able to respond to an AUX\_CH transaction with the time specified within T3 max.

## Display Port panel B/L power sequence timing parameter:

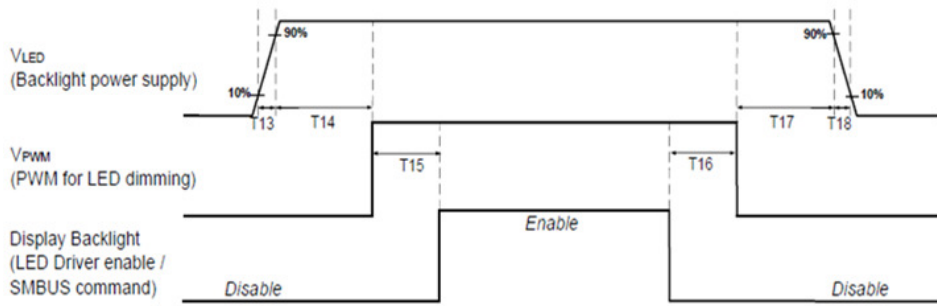

Note : When the adapter is hot plugged, the backlight power supply sequence is shown as below.

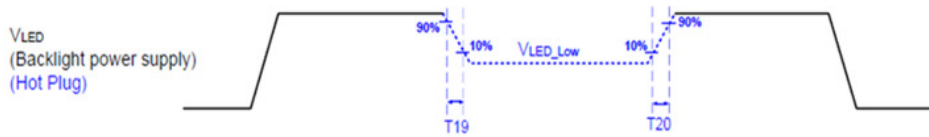

	Min (ms)	Max (ms)
T13	0.5	10
T14	10	-
T15	10	-
T16	10	-
T17	10	-
T18	0.5	10
T19	1 <sup>*</sup>	-
T20	1 <sup>*</sup>	-

Seamless change:  $T19/T20 = 5 \times T_{PWM}^*$

<sup>\*</sup> $T_{PWM} = 1/PWM \text{ Frequency}$



## 7. Panel Reliability Test

### 7.1 Vibration Test

**Test Spec:**

- Test method: Non-Operation
- Acceleration: 1.5 G
- Frequency: 10 - 500Hz Random
- Sweep: 30 Minutes each Axis (X, Y, Z)

### 7.2 Shock Test

**Test Spec:**

- Test method: Non-Operation
- Acceleration: 220 G , Half sine wave
- Active time: 2 ms
- Pulse: X,Y,Z .one time for each side

### 7.3 Reliability Test

Items	Required Condition	Note
Temperature Humidity Bias	Ta= 40°C, 90%RH, 300h	
High Temperature Operation	Ta= 50°C, Dry, 300h	
Low Temperature Operation	Ta= 0°C, 300h	
High Temperature Storage	Ta= 60°C, 35%RH, 300h	
Low Temperature Storage	Ta= -20°C, 50%RH, 250h	
Thermal Shock Test	Ta=-20°C to 60°C, Duration at 30 min, 100 cycles	
ESD	Contact : ±8 KV Air : ±15 KV	Note 1

**Note1:** According to EN 61000-4-2 , ESD class B: Some performance degradation allowed.

Self-recoverable.

No data lost, No hardware failures.

**Remark:** MTBF (Excluding the LED): 30,000 hours with a confidence level 90%

## 8. Mechanical Characteristics

### 8.1 LCM Outline Dimension

# Front view 2D drawing

Remind RD Solid line and dotted line

www.yslcd.com.tw

# Rear view 2D drawing

Remind RD Solid line and dotted line

Note: Prevention IC damage, IC positions not allowed any overlap over these areas.

## 9. Shipping and Package

### 9.1 Shipping Label Format



### 9.2 Carton Label Format



### 9.3 Carton Package

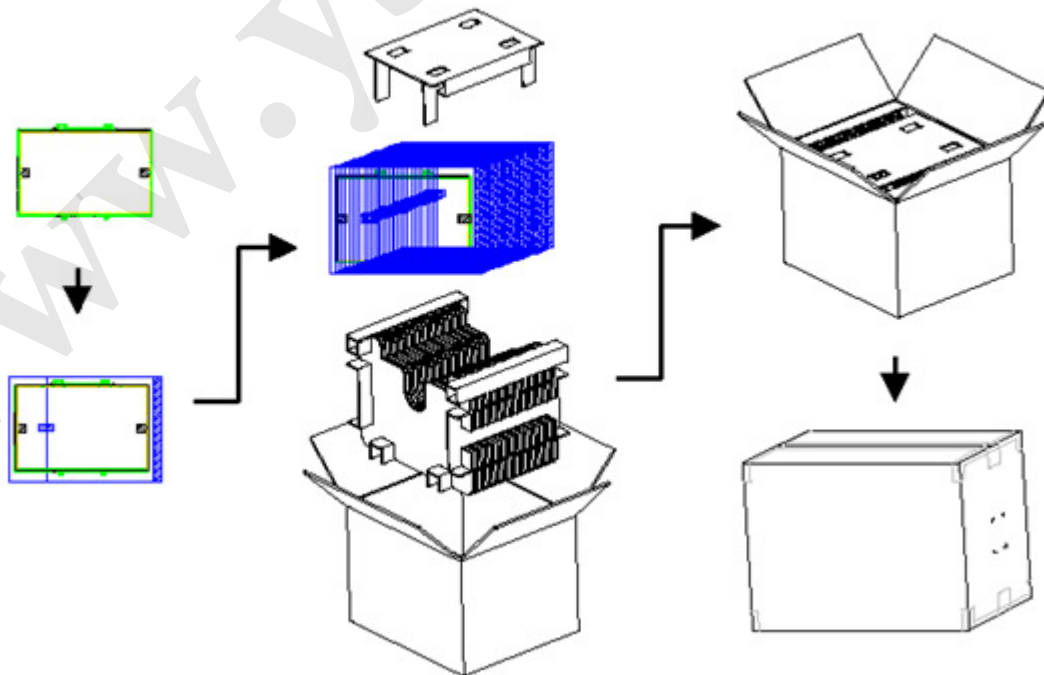

## 9.4 Shipping Package of Palletizing Sequence

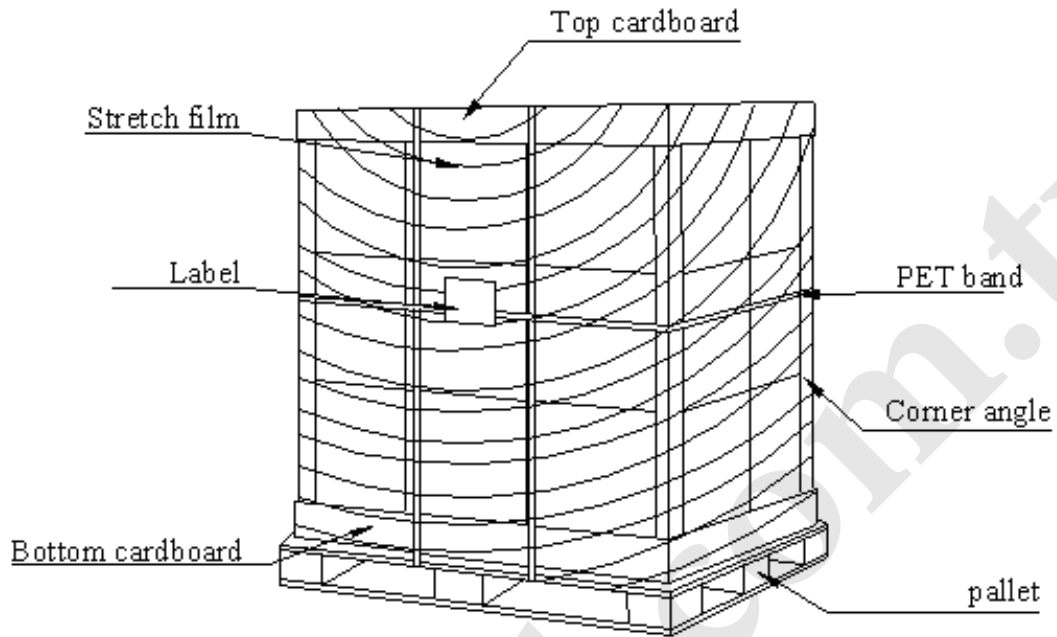



**10. Appendix: EDID Description**

TBD

[www.yshcd.com.tw](http://www.yshcd.com.tw)