



Contents

1. Handling Precautions 4

2. General Description 5

 2.1 General Specification 5

 2.2 Optical Characteristics 6

3. Functional Block Diagram 11

4. Absolute Maximum Ratings..... 12

 4.1 Absolute Ratings of TFT LCD Module 12

 4.2 Absolute Ratings of Environment 12

5. Electrical Characteristics..... 13

 5.1 TFT LCD Module..... 13

 5.2 Backlight Unit 15

6. Signal Interface Characteristic..... 16

 6.1 Pixel Format Image 16

 6.2 The Input Data Format 17

 6.3 Integration Interface Requirement..... 18

 6.4 Interface Timing 20

7. Panel Reliability Test 22

 7.1 Vibration Test 22

 7.2 Shock Test 22

 7.3 Reliability Test..... 22

8. Mechanical Characteristics..... 23

 8.1 LCM Outline Dimension..... 23

 8.2 Screw Hole Depth and Center Position..... 25

9. Shipping and Package 26

 9.1 Shipping Label Format..... 26

 9.2 Carton Package..... 27

 9.3 Shipping Package of Palletizing Sequence..... 27

10. Appendix: EDID Description..... 28

1. Handling Precautions

- 1) Since front polarizer is easily damaged, pay attention not to scratch it.
- 2) Be sure to turn off power supply when inserting or disconnecting from input connector.
- 3) Wipe off water drop immediately. Long contact with water may cause discoloration or spots.
- 4) When the panel surface is soiled, wipe it with absorbent cotton or other soft cloth.
- 5) Since the panel is made of glass, it may break or crack if dropped or bumped on hard surface.
- 6) Since CMOS LSI is used in this module, take care of static electricity and insure human earth when handling.
- 7) Do not open nor modify the Module Assembly.
- 8) Do not press the reflector sheet at the back of the module to any directions.
- 9) At the insertion or removal of the Signal Interface Connector, be sure not to rotate nor tilt the Interface Connector of the TFT Module.
- 11) After installation of the TFT Module into an enclosure (Notebook PC Bezel, for example), do not twist nor bend the TFT Module even momentary. At designing the enclosure, it should be taken into consideration that no bending/twisting forces are applied to the TFT Module from outside. Otherwise the TFT Module may be damaged.
- 12) Small amount of materials having no flammability grade is used in the LCD module. The LCD module should be supplied by power complied with requirements of Limited Power Source (IEC60950 or UL1950), or be applied exemption.
- 13) Disconnecting power supply before handling LCD modules, it can prevent electric shock, DO NOT TOUCH the electrode parts, cables, connectors and LED circuit part of TFT module that a LED light bar build in as a light source of back light unit. It can prevent electrostatic breakdown.

2. General Description

B140XW01 V6 is a Color Active Matrix Liquid Crystal Display composed of a TFT LCD panel, a driver circuit, and LED backlight system. The screen format is intended to support the 16:9 HD, 1366(H) x768(V) screen and 262k colors (RGB 6-bits data driver) with LED backlight driving circuit. All input signals are LVDS interface compatible.

B140XW01 V6 is designed for a display unit of notebook style personal computer and industrial machine.

2.1 General Specification

The following items are characteristics summary on the table at 25 °C condition:

Items	Unit	Specifications			
Screen Diagonal	[mm]	354.95			
Active Area	[mm]	309.4 X173.95			
Pixels H x V		1366x3(RGB) x 768			
Pixel Pitch	[mm]	0.2265X0.2265			
Pixel Format		R.G.B. Vertical Stripe			
Display Mode		Normally White			
White Luminance (ILED=20mA) (Note: ILED is LED current)	[cd/m ²]	220 typ. (5 points average) 187 min. (5 points average)			
Luminance Uniformity		1.25 max. (5 points)			
Contrast Ratio		500 typ			
Response Time	[ms]	8 typ / 16 Max			
Nominal Input Voltage VDD	[Volt]	+3.3 typ.			
Power Consumption	[Watt]	4.4 max. (Include Logic and Blu power)			
Weight	[Grams]	350 max.			
Physical Size Include bracket	[mm]		Min.	Typ.	Max.
		Length	323	323.5	324
		Width	191.5	192.0	192.5
		Thickness			5.2
Electrical Interface		1 channel LVDS			
Glass Thickness	[mm]	0.5			
Surface Treatment		Glare, Hardness 3H,			
Support Color		262K colors (RGB 6-bit)			



Product Specification

AU OPTRONICS CORPORATION

Temperature Range Operating	[°C]	0 to +50
Storage (Non-Operating)	[°C]	-20 to +60
RoHS Compliance		RoHS Compliance

2.2 Optical Characteristics

The optical characteristics are measured under stable conditions at 25°C (Room Temperature) :

Item	Symbol	Conditions	Min.	Typ.	Max.	Unit	Note	
White Luminance		5 points average	187	220	-	cd/m ²	1, 4, 5.	
Viewing Angle	θ_R	Horizontal (Right) CR = 10 (Left)		45	-	degree	4, 9	
	θ_L			45	-			
	ϕ_H	Vertical (Upper) CR = 10 (Lower)		15	-			
	ϕ_L			35	-			
Luminance Uniformity	δ_{5P}	5 Points	-	-	1.25		1, 3, 4	
Luminance Uniformity	δ_{13P}	13 Points	-	-	1.60		2, 3, 4	
Contrast Ratio	CR		400	500	-		4, 6	
Cross talk	%				4		4, 7	
Response Time	T_r	Rising	-	-	-	msec	4, 8	
	T_f	Falling	-	-	-			
	T_{RT}	Rising + Falling	-	8	16			
Color / Chromaticity Coordinates	Red	Rx				CIE 1931	4	
		Ry						
	Green	Gx						
		Gy						
	Blue	Bx						
		By						
	White	Wx		0.283	0.313			0.343
		Wy		0.299	0.329			0.359
NTSC	%		-	60	-			

Note 1: 5 points position (Ref: Active area)

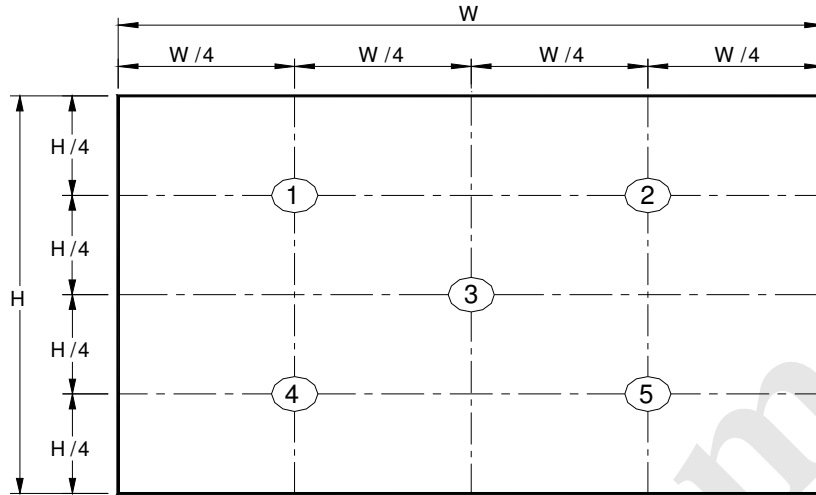

Note 2: 13 points position (Ref: Active area)

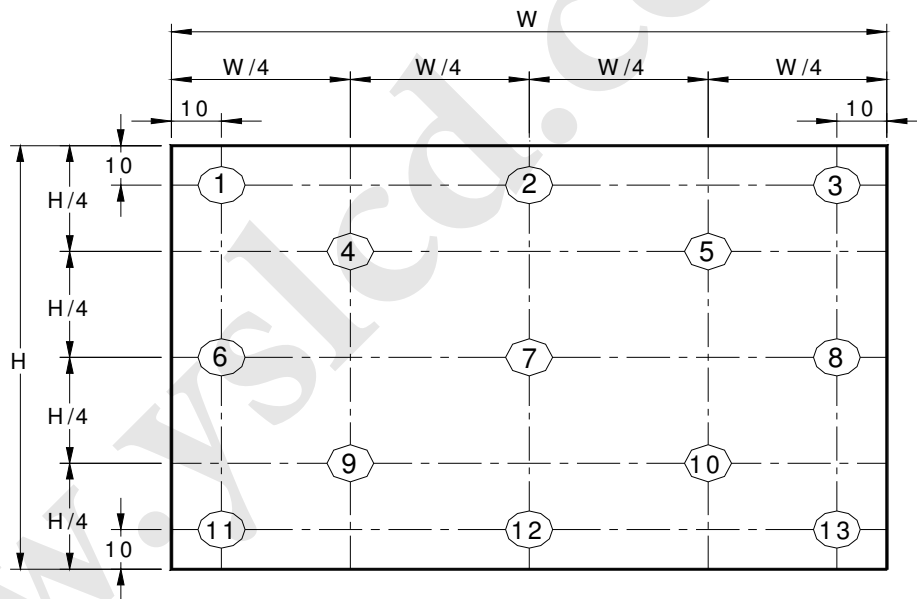

Note 3: The luminance uniformity of 5 or 13 points is defined by dividing the maximum luminance values by the minimum test point luminance

$$\delta_{w5} = \frac{\text{Maximum Brightness of five points}}{\text{Minimum Brightness of five points}}$$

$$\delta_{w13} = \frac{\text{Maximum Brightness of thirteen points}}{\text{Minimum Brightness of thirteen points}}$$

Note 4: Measurement method

The LCD module should be stabilized at given temperature for 30 minutes to avoid abrupt temperature change during measuring. In order to stabilize the luminance, the measurement should be executed after lighting

Backlight for 30 minutes in a stable, windless and dark room, and it should be measured in the center of screen.

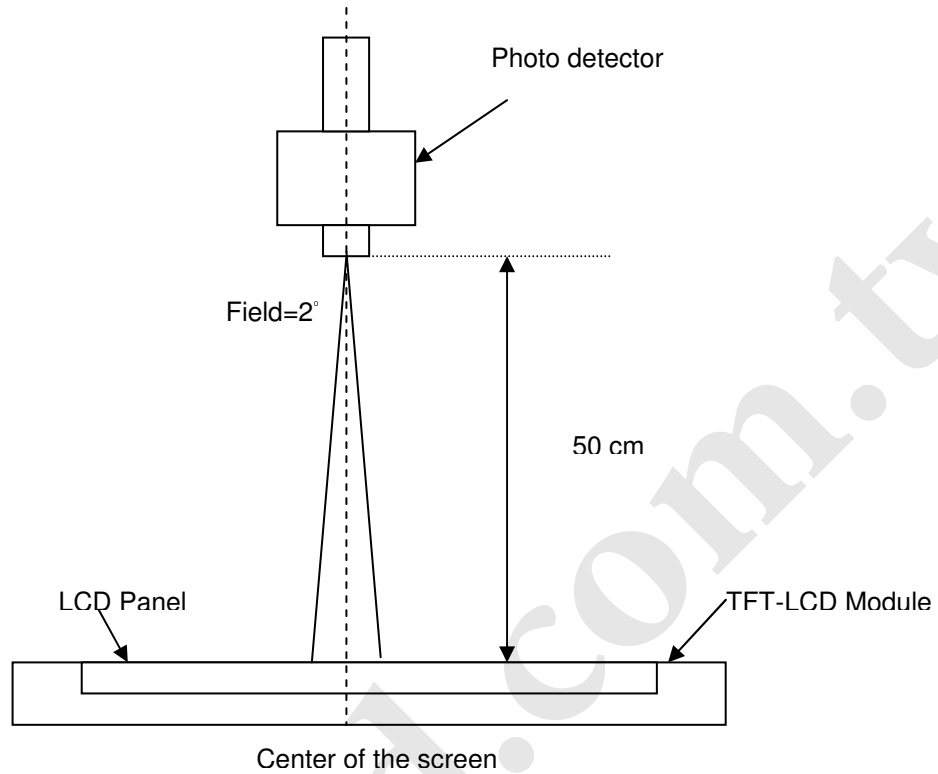

Note 5 : Definition of Average Luminance of White (Y_L):

Measure the luminance of gray level 63 at 5 points · $Y_L = [L(1) + L(2) + L(3) + L(4) + L(5)] / 5$

$L(x)$ is corresponding to the luminance of the point X at Figure in Note (1).

Note 6 : Definition of contrast ratio:

Contrast ratio is calculated with the following formula.

$$\text{Contrast ratio (CR)} = \frac{\text{Brightness on the "White" state}}{\text{Brightness on the "Black" state}}$$

Note 7 : Definition of Cross Talk (CT)

$$CT = |Y_B - Y_A| / Y_A \times 100 (\%)$$

Where

Y_A = Luminance of measured location without gray level 0 pattern (cd/m^2)

Y_B = Luminance of measured location with gray level 0 pattern (cd/m^2)

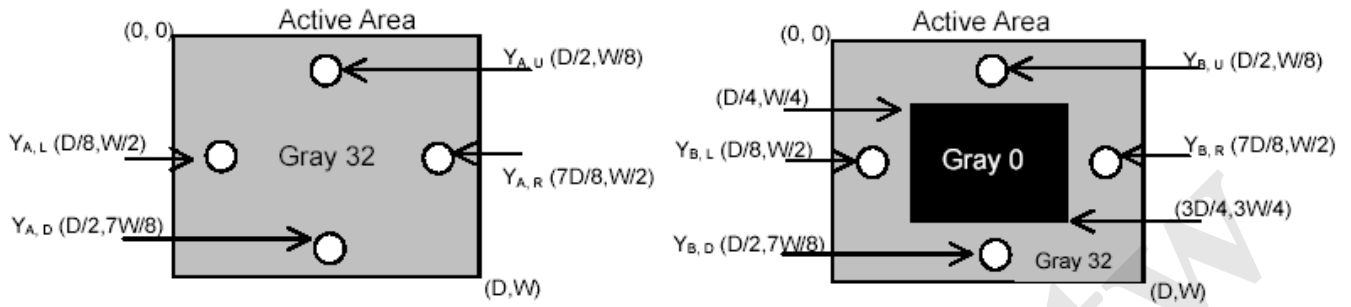

Note 8: Definition of response time:

The output signals of BM-7 or equivalent are measured when the input signals are changed from "Black" to "White" (falling time) and from "White" to "Black" (rising time), respectively. The response time interval between the 10% and 90% of amplitudes. Refer to figure as below.

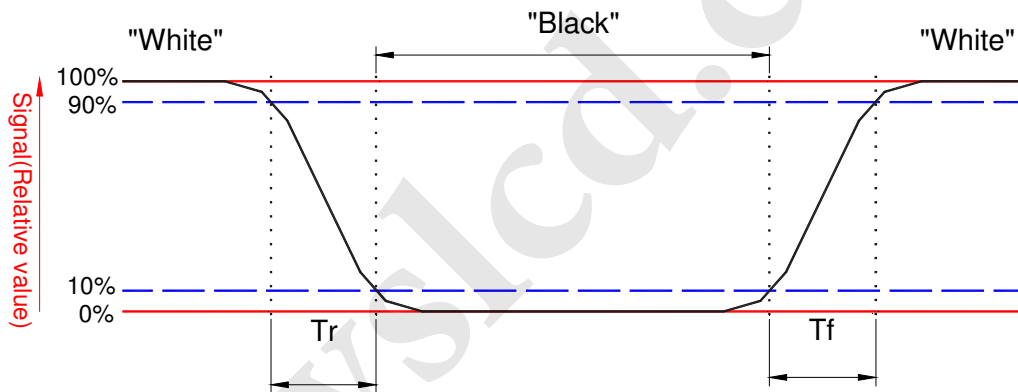

Note 9. Definition of viewing angle

Viewing angle is the measurement of contrast ratio ≥ 10 , at the screen center, over a 180° horizontal and 180° vertical range (off-normal viewing angles). The 180° viewing angle range is broken down as follows; 90° (θ) horizontal left and right and 90° (Φ) vertical, high (up) and low (down). The measurement direction is typically perpendicular to the display surface with the screen rotated about its center to develop the desired measurement viewing angle.

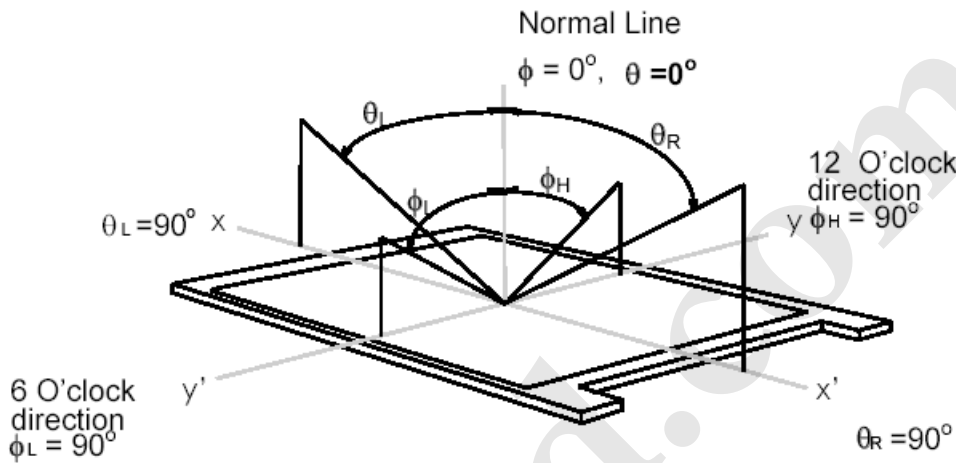

3. Functional Block Diagram

The following diagram shows the functional block of the 14.0 inches wide Color TFT/LCD 40 Pin one channel Module

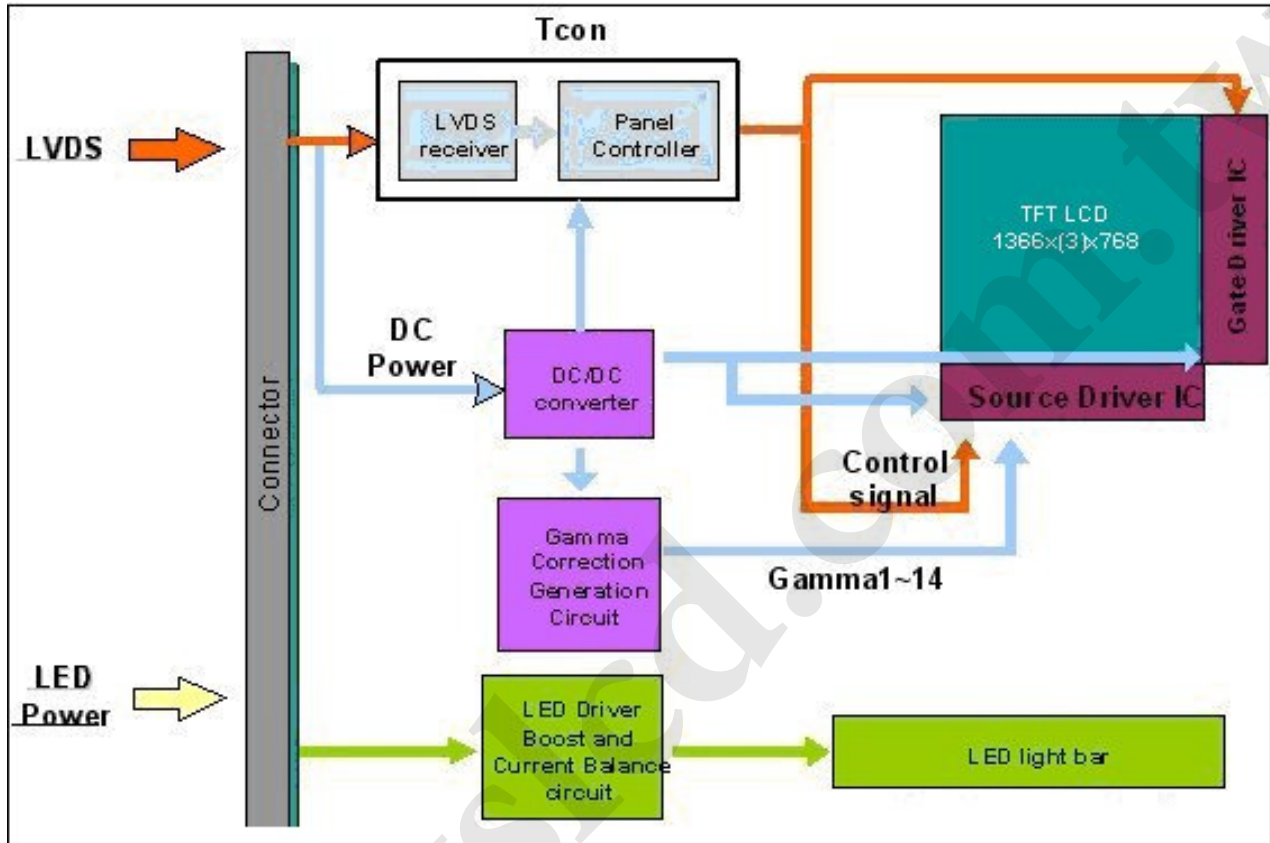

4. Absolute Maximum Ratings

An absolute maximum rating of the module is as following:

4.1 Absolute Ratings of TFT LCD Module

Item	Symbol	Min	Max	Unit	Conditions
Logic/LCD Drive Voltage	Vin	-0.3	+4.0	[Volt]	Note 1,2

4.2 Absolute Ratings of Environment

Item	Symbol	Min	Max	Unit	Conditions
Operating Temperature	TOP	0	+50	[°C]	Note 4
Operation Humidity	HOP	5	95	[%RH]	Note 4
Storage Temperature	TST	-20	+60	[°C]	Note 4
Storage Humidity	HST	5	95	[%RH]	Note 4

Note 1: At Ta (25°C)

Note 2: Permanent damage to the device may occur if exceed maximum values

Note 3: LED specification refer to section 5.2

Note 4: For quality performance, please refer to AUO IIS (Incoming Inspection Standard).

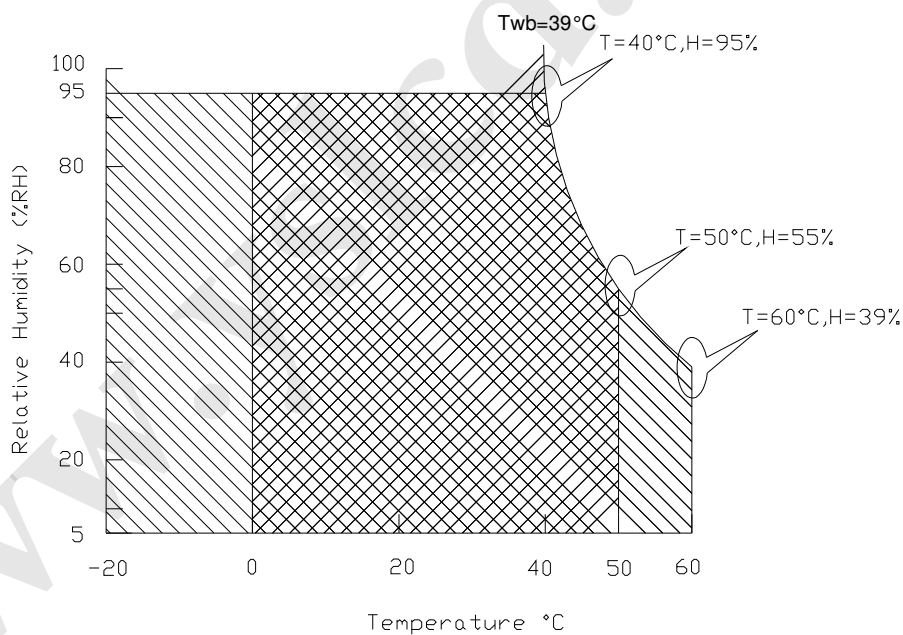

Operating Range

Storage Range +

5. Electrical Characteristics

5.1 TFT LCD Module

5.1.1 Power Specification

Input power specifications are as follows;

The power specification are measured under 25°C and frame frequency under 60Hz

Symble	Parameter	Min	Typ	Max	Units	Note
VDD	Logic/LCD Drive Voltage	3.0	3.3	3.6	[Volt]	
PDD	VDD Power	-	0.8	1.0	[Watt]	Note 1/2
IDD	IDD Current	-	267	333	[mA]	Note 1/2
IRush	Inrush Current	-	-	2000	[mA]	Note 3
VDDrp	Allowable Logic/LCD Drive Ripple Voltage	-	-	100	[mV] p-p	

Note 1 : Maximum Measurement Condition : Black Pattern

Note 2 : Typical measurement condition : Mosaic pattern 1

Note 3 : Measure Condition

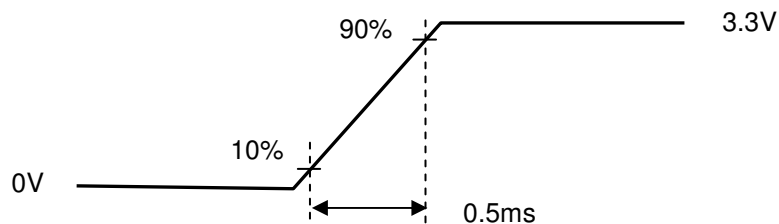
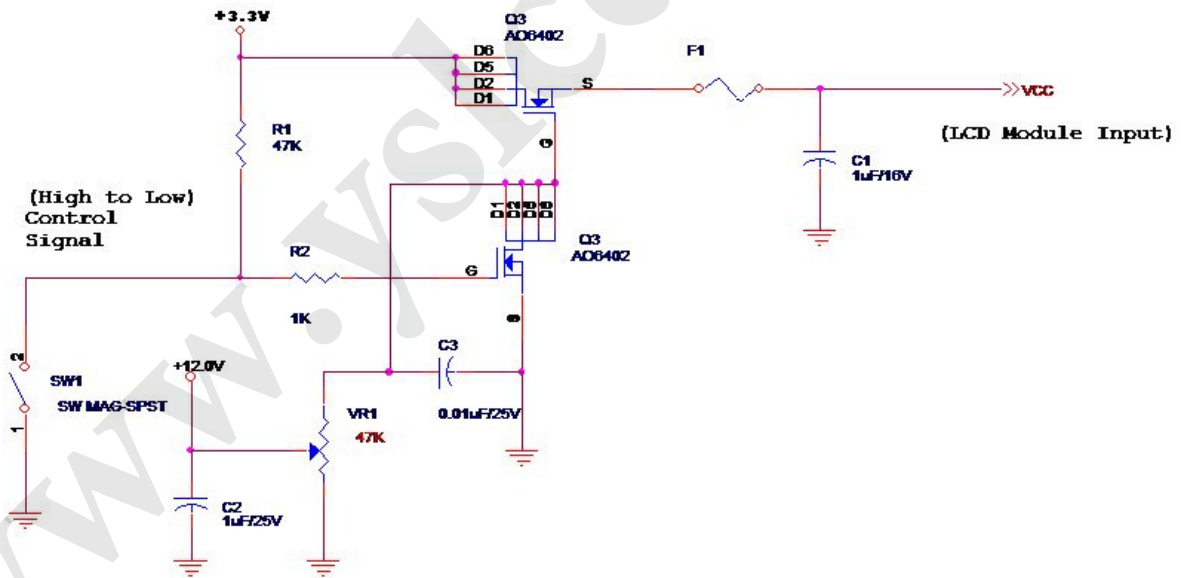

5.1.2 Signal Electrical Characteristics

Input signals shall be low or High-impedance state when VDD is off.

Signal electrical characteristics are as follows;

Parameter	Condition	Min	Max	Unit
V_{th}	Differential Input High Threshold ($V_{cm}=+1.2V$)		100	[mV]
V_{tl}	Differential Input Low Threshold ($V_{cm}=+1.2V$)	-100	-	[mV]
V_{ID}	Differential Input Voltage	100	600	[mV]
V_{cm}	Differential Input Common Mode Voltage	1.125	1.375	[V]

Note: LVDS Signal Waveform

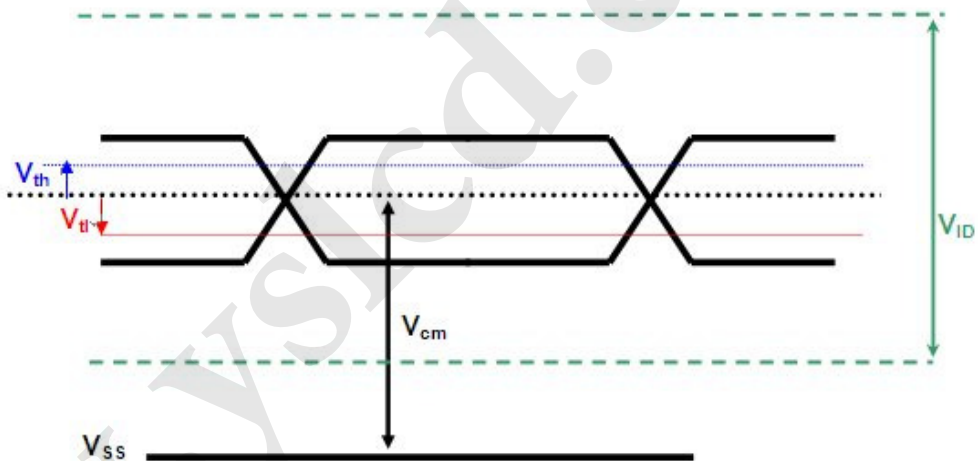

5.2 Backlight Unit

5.2.1 LED characteristics

Parameter	Symbol	Min	Typ	Max	Units	Condition
Backlight Power Consumption	PLED	-	-	3.4	[Watt]	(Ta=25°C), Note 1
LED Life-Time	N/A	12,000	-	-	Hour	(Ta=25°C), Note 2

Note 1: Calculator value for reference $P_{LED} = V_F$ (Normal Distribution) * I_F (Normal Distribution) / Efficiency

Note 2: The LED life-time define as the estimated time to 50% degradation of initial luminous.

5.2.2 Backlight input signal characteristics

Parameter	Symbol	Min	Typ	Max	Units	Remark
LED Power Supply	VLED	6.0	12.8	21.0	[Volt]	Define as Connector Interface (Ta=25°C)
LED Enable Input High Level	VLED_EN	2.5	-	5.5	[Volt]	
LED Enable Input Low Level		-	-	0.8	[Volt]	
PWM Logic Input High Level	VPWM_EN	2.5	-	5.0	[Volt]	
PWM Logic Input Low Level		-	-	0.8	[Volt]	
PWM Input Frequency	FPWM	200	1K	10K	Hz	
PWM Duty Ratio	Duty	5	--	100	%	

6. Signal Interface Characteristic

6.1 Pixel Format Image

Following figure shows the relationship of the input signals and LCD pixel format.

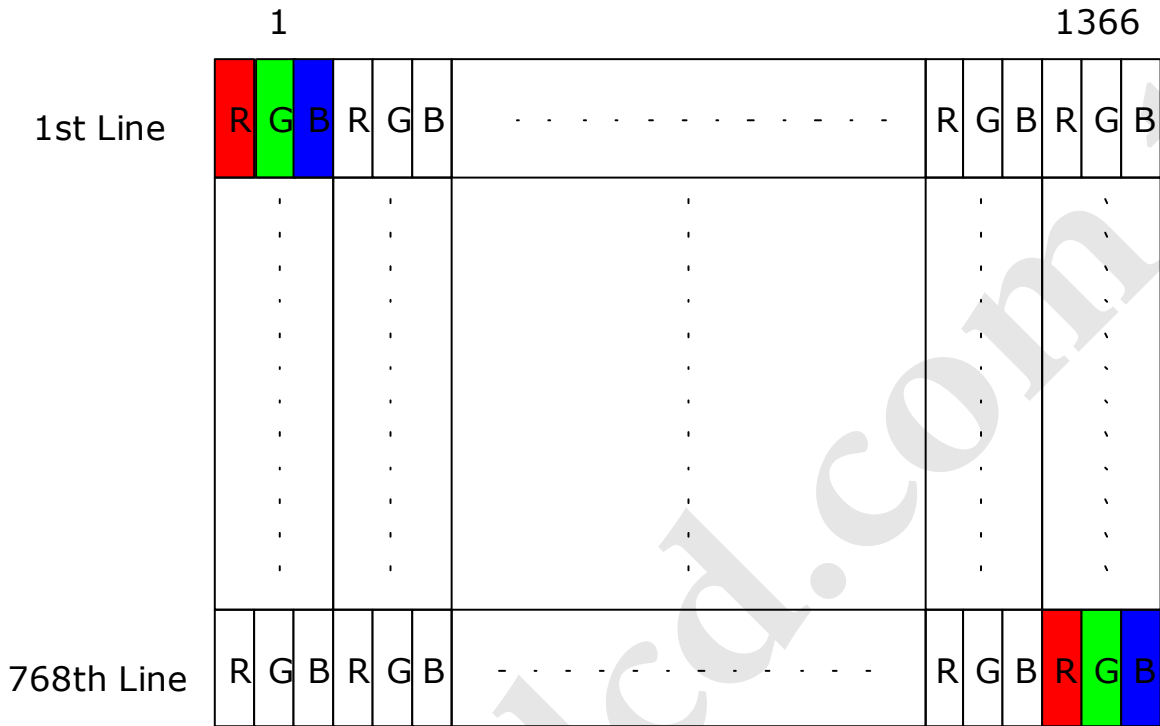

6.2 The Input Data Format

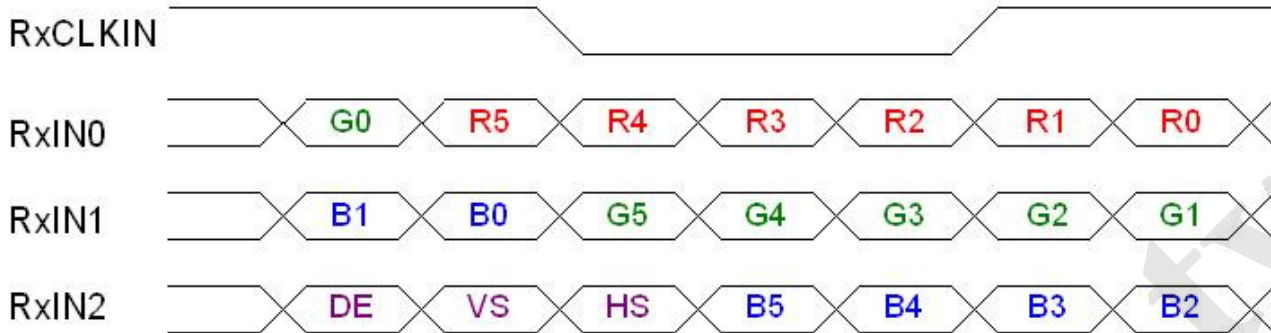

Signal Name	Description	
R5 R4 R3 R2 R1 R0	Red Data 5 (MSB) Red Data 4 Red Data 3 Red Data 2 Red Data 1 Red Data 0 (LSB)	Red-pixel Data Each red pixel's brightness data consists of these 6 bits pixel data.
G5 G4 G3 G2 G1 G0	Green Data 5 (MSB) Green Data 4 Green Data 3 Green Data 2 Green Data 1 Green Data 0 (LSB)	Green-pixel Data Each green pixel's brightness data consists of these 6 bits pixel data.
B5 B4 B3 B2 B1 B0	Blue Data 5 (MSB) Blue Data 4 Blue Data 3 Blue Data 2 Blue Data 1 Blue Data 0 (LSB)	Blue-pixel Data Each blue pixel's brightness data consists of these 6 bits pixel data.
RxCLKIN	Data Clock	The signal is used to strobe the pixel data and DE signals. All pixel data shall be valid at the falling edge when the DE signal is high.
DE	Display Timing	This signal is strobed at the falling edge of RxCLKIN. When the signal is high, the pixel data shall be valid to be displayed.
VS	Vertical Sync	The signal is synchronized to RxCLKIN .
HS	Horizontal Sync	The signal is synchronized to RxCLKIN .

Note: Output signals from any system shall be low or High-impedance state when VDD is off.

6.3 Integration Interface Requirement

6.3.1 Connector Description

Physical interface is described as for the connector on module.

These connectors are capable of accommodating the following signals and will be following components.

Connector Name / Designation	For Signal Connector
Manufacturer	STM
Type / Part Number	MSAK24025P40
Mating Housing/Part Number	Mating of MSAK24025P40

6.3.2 Pin Assignment

LVDS is a differential signal technology for LCD interface and high speed data transfer device.

PIN#	Signal Name	Description
1	NC	No Connection (Reserve)
2	VDD	Power Supply +3.3V
3	VDD	Power Supply +3.3V
4	VEDID	EDID +3.3V Power
5	NC	No Connect (Reserve)
6	CLK_EDID	EDID Clock Input
7	DAT_EDID	EDID Data Input
8	RxOIN0-	-LVDS Differential Data INPUT(Odd R0-R5,G0)
9	RxOIN0+	+LVDS Differential Data INPUT(Odd R0-R5,G0)
10	VSS	Ground
11	RxOIN1-	-LVDS Differential Data INPUT(Odd G1-G5,B0-B1)
12	RxOIN1+	+LVDS Differential Data INPUT(Odd G1-G5,B0-B1)
13	VSS	Ground
14	RxOIN2-	-LVDS Differential Data INPUT(Odd B2-B5,HS,VS,DE)
15	RxOIN2+	+LVDS Differential Data INPUT(Odd B2-B5,HS,VS,DE)
16	VSS	Ground
17	RxOCKIN-	-LVDS Odd Differential Clock INPUT
18	RxOCKIN+	-LVDS Odd Differential Clock INPUT
19	VSS	Ground
20	NC	No connection
21	NC	No connection
22	VSS	Ground

23	NC	No connection
24	NC	No connection
25	VSS	Ground
26	NC	No connection
27	NC	No connection
28	VSS	Ground
29	NC	No connection
30	NC	No connection
31	VLED_GND	LED Ground
32	VLED_GND	LED Ground
33	VLED_GND	LED Ground
34	NC	No Connection (Reserve)
35	S_PWMIN	System PWM signal Input
36	BL_ON	LED enable pin(+3V input, +5V tolerance)
37	NC	No Connection (Reserve)
38	VLED	LED Power Supply 6V - 21V
39	VLED	LED Power Supply 6V - 21V
40	VLED	LED Power Supply 6V - 21V

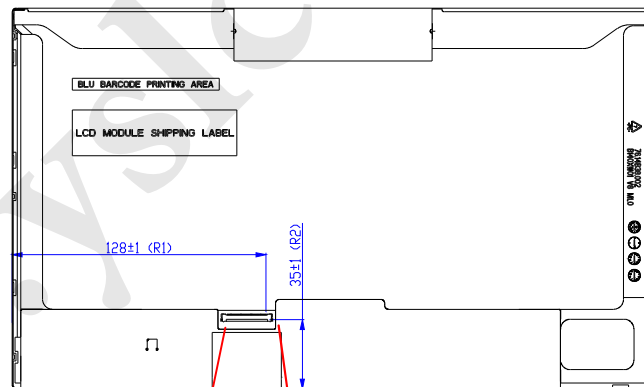

Connector

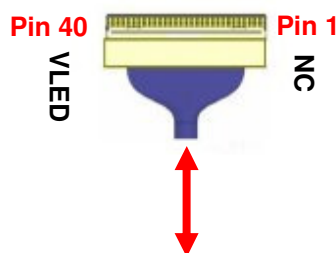
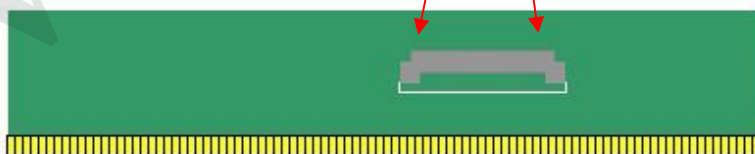

Note1: Input signals shall be low or High-impedance state when VDD is off.

6.4 Interface Timing

6.4.1 Timing Characteristics

Basically, interface timings should match the 1366x768 /60Hz manufacturing guide line timing.

Parameter	Symbol	Min.	Typ.	Max.	Unit	
Frame Rate	-	40	60	-	Hz	
Clock frequency	$1/T_{\text{Clock}}$	50	69.05	80	MHz	
Vertical Section	Period	T_V	776	803	1023	T_{Line}
	Active	T_{VD}	768			
	Blanking	T_{VB}	8	35	255	
Horizontal Section	Period	T_H	1396	1436	2047	T_{Clock}
	Active	T_{HD}	1366			
	Blanking	T_{HB}	40	70	681	

Note : DE mode only

6.4.2 Timing diagram

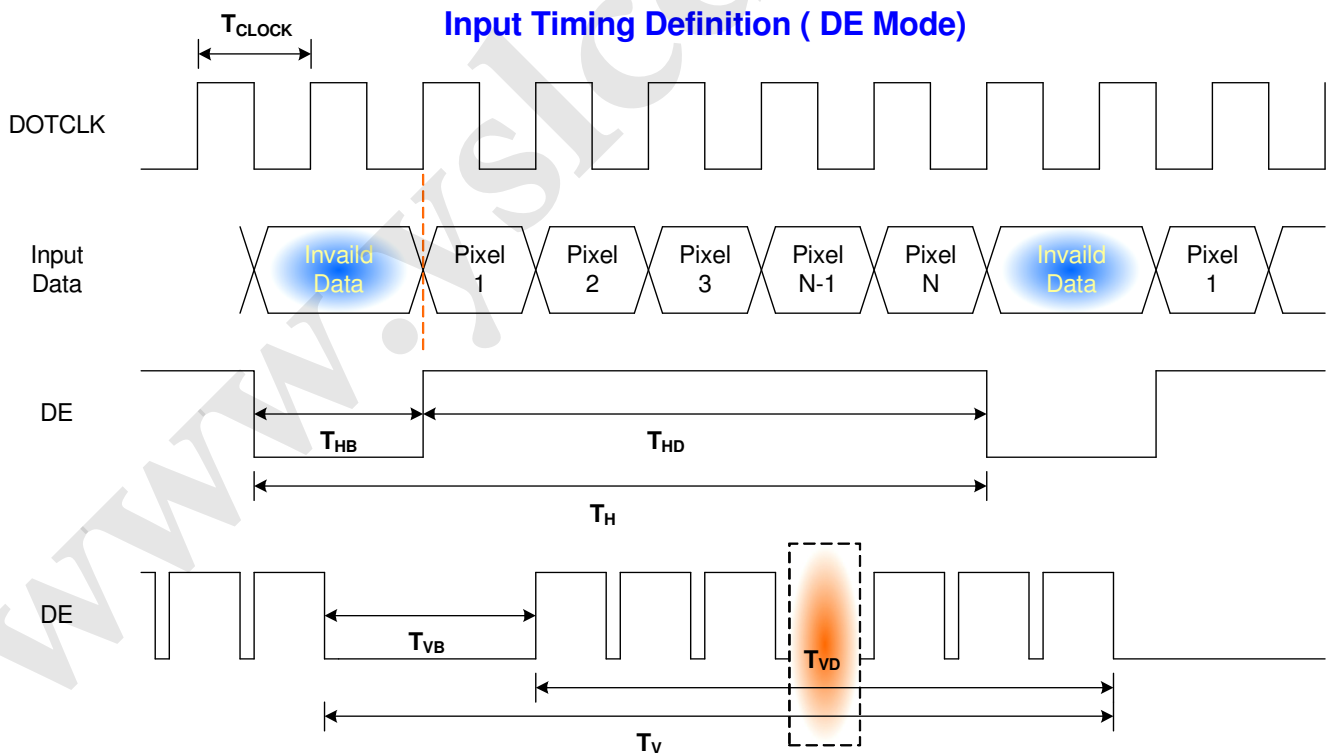

6.5 Power ON/OFF Sequence

Power on/off sequence is as follows. Interface signals and LED on/off sequence are also shown in the chart. Signals from any system shall be Hi-Z state or low level when VDD is off.

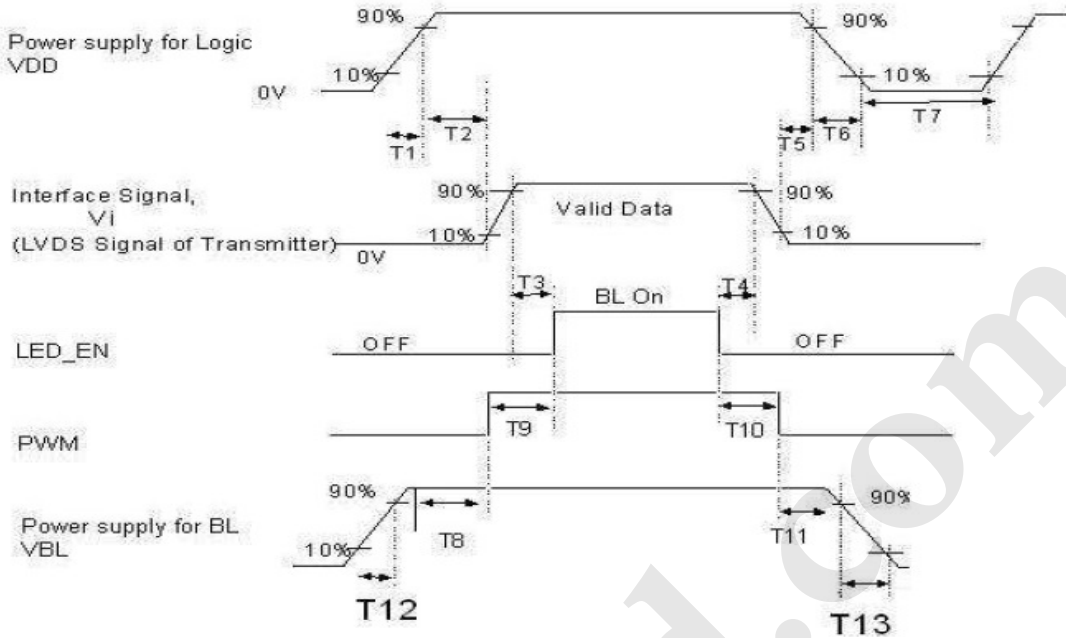

Power Sequence Timing				
Parameter	Value			Units
	Min.	Typ.	Max.	
T1	0.5	-	10	ms
T2	0	-	50	
T3	200	-	-	
T4	0	-	-	
T5	0	-	-	
T6	0	-	10	
T7	150	-	-	
T8	0	-	-	
T9	0	-	-	
T10	0	-	-	
T11	0	-	-	
T12	0.5	-	-	
T13	0	-	-	

Note: If T4 < 200ms, the display garbage may occur. We suggest T4 > 200ms to avoid the display garbage.

Note : If T1 or T12 < 0.5ms, the inrush current may cause the damage of fuse. If T1 or T12 < 0.5ms, the inrush current I^2t is under typical melt of fuse spec, there is no above-mentioned problem.

7. Panel Reliability Test

7.1 Vibration Test

Test Spec:

- Test method: Non-Operation
- Acceleration: 1.5 G
- Frequency: 10 - 500Hz Random
- Sweep: 30 Minutes each Axis (X, Y, Z)

7.2 Shock Test

Test Spec:

- Test method: Non-Operation
- Acceleration: 220 G , Half sine wave
- Active time: 2 ms
- Pulse: X,Y,Z .one time for each side

7.3 Reliability Test

Items	Required Condition	Note
Temperature Humidity Bias	Ta= 40°C, 90%RH, 300h	
High Temperature Operation	Ta= 50°C, Dry, 300h	
Low Temperature Operation	Ta= 0°C, 300h	
High Temperature Storage	Ta= 60°C, 35%RH, 300h	
Low Temperature Storage	Ta= -20°C, 50%RH, 250h	
Thermal Shock Test	Ta=-20°C to 60°C, Duration at 30 min, 100 cycles	
ESD	Contact : ±8 KV Air : ±15 KV	Note 1

Note1: According to EN 61000-4-2 , ESD class B: Some performance degradation allowed. No data lost
 . Self-recoverable. No hardware failures.

Remark: MTBF (Excluding the LED): 30,000 hours with a confidence level 90%

8. Mechanical Characteristics

8.1 LCM Outline Dimension Note: Prevention IC damage, IC positions not allowed any overlap over these areas.

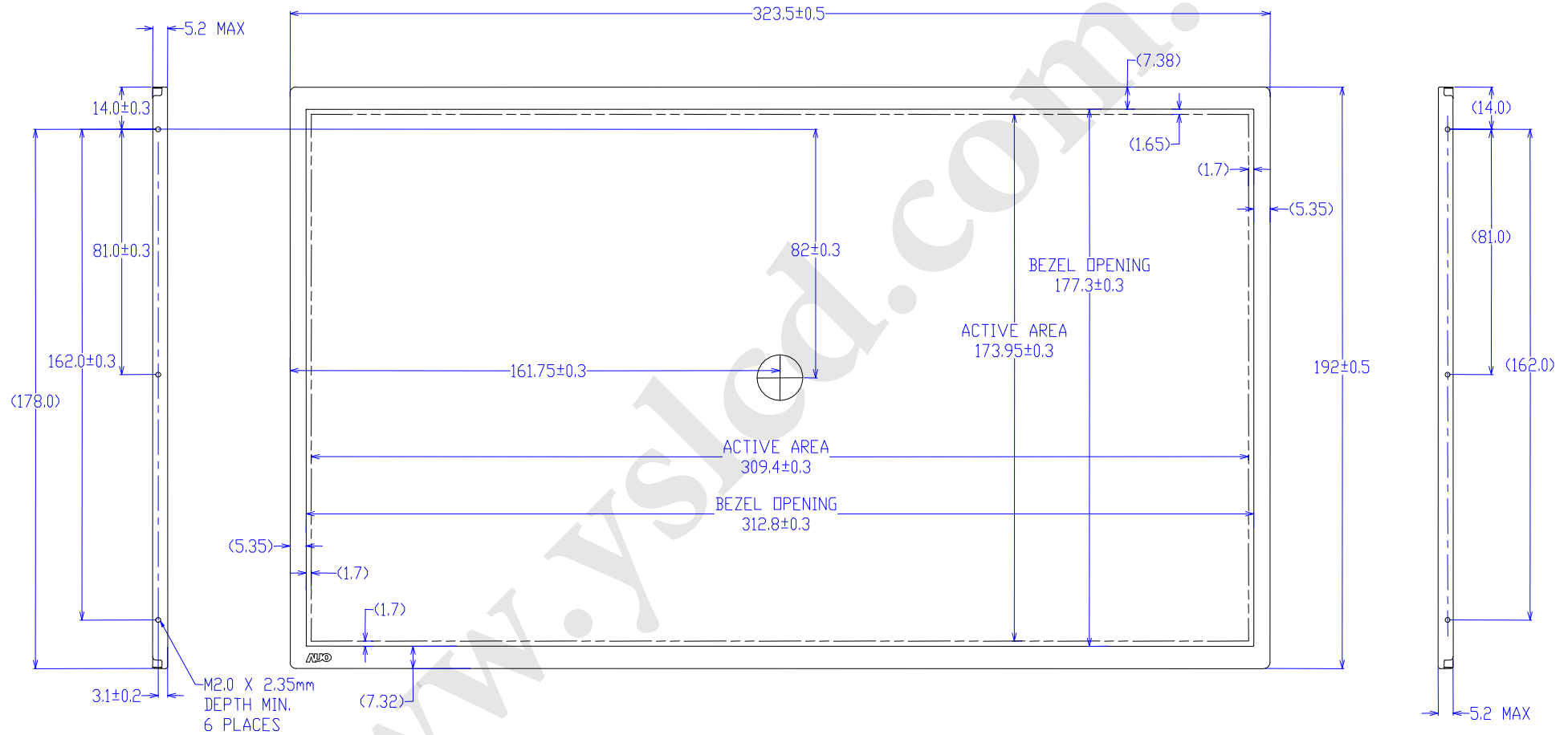

NOTE

1. 14.0" LCD module mechanical outline dimension
2. All dimension in mm
3. As viewed from front of LCD modules

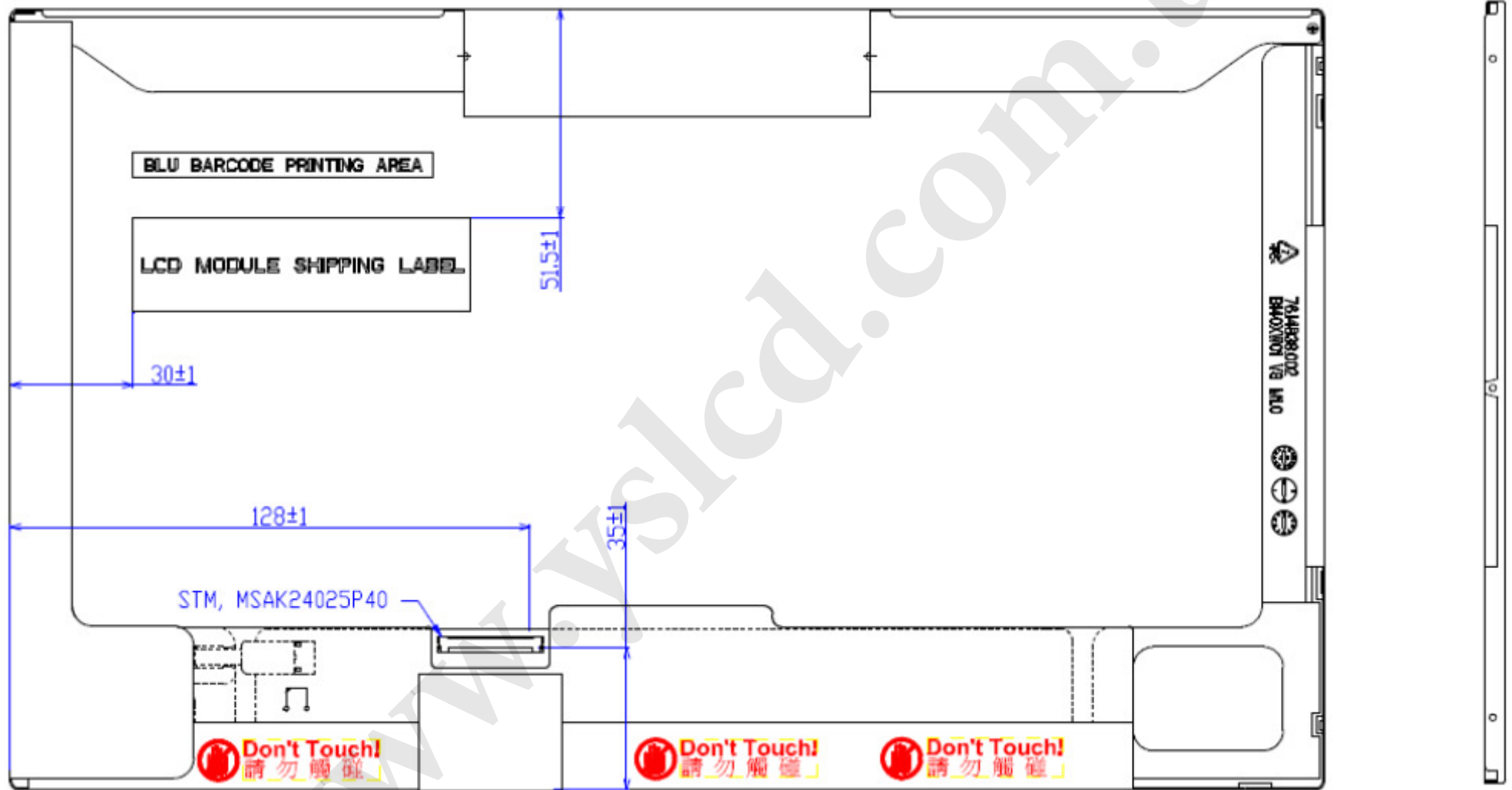

8.2 Screw Hole Depth and Center Position

Screw hole minimum depth from side surface is 2.35mm (ref drawing).

The center of screw hole center location is 3.1 ± 0.2 mm from front surface

Screw Torque: Maximum 2.5 kgf-cm

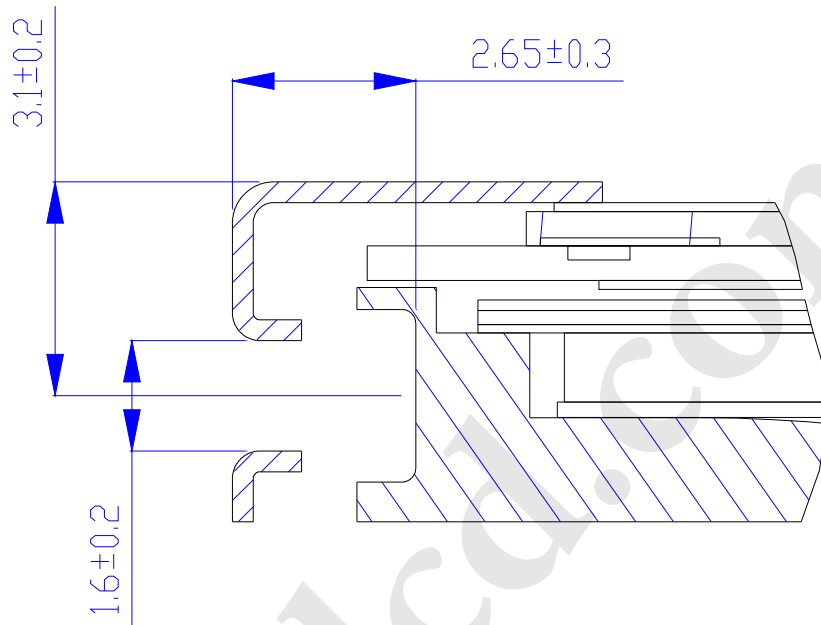



9. Shipping and Package

9.1 Shipping Label Format

TBD

www.yslcd.com.tw

9.2 Carton Package

The outside dimension of carton is 454 (L)mm x 376 (W)mm x 302 (H)mm

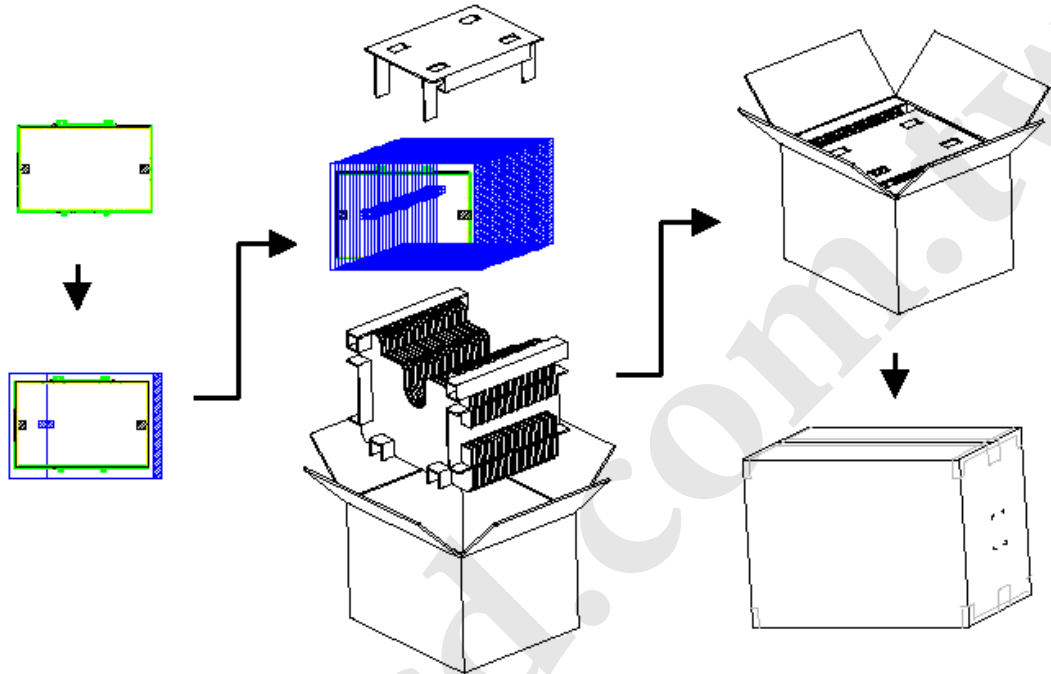

9.3 Shipping Package of Palletizing Sequence

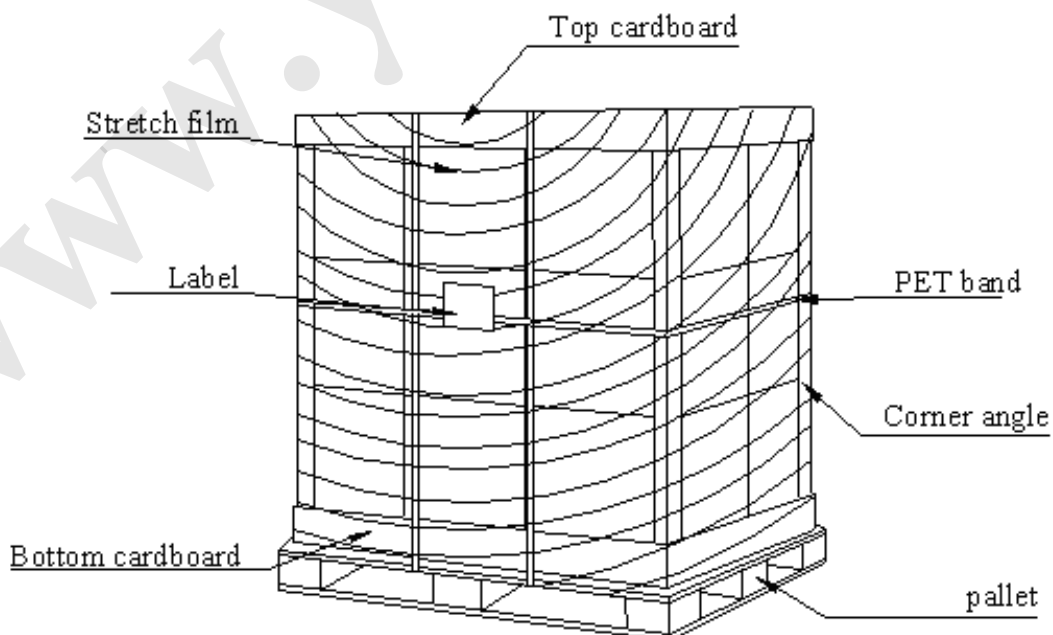



10. Appendix: EDID Description

TBD

www.yshcd.com.tw