



Product Specification

AU OPTRONICS CORPORATION

() Preliminary Specification

(V) Final Specification

Module	14.0" (13.97") HD 16:9 Color TFT-LCD with LED Backlight design
Model Name	B140XW03 V2 (0A)
Note ()	LED Backlight with driving circuit design

Customer	Date
Checked & Approved by	Date
<p>Note: This Specification is subject to change without notice.</p>	

Approved by	Date
<u>Bonnie Chen</u>	<u>10/06/2010</u>
Prepared by	Date
<u>Louis Li</u>	<u>10/06/2010</u>
<p>NBBU Marketing Division AU Optronics corporation</p>	



Product Specification

AU OPTRONICS CORPORATION

Contents

1. Handling Precautions	4
2. General Description	5
2.1 General Specification	5
2.2 Optical Characteristics	6
3. Functional Block Diagram	11
4. Absolute Maximum Ratings.....	12
4.1 Absolute Ratings of TFT LCD Module	12
4.2 Absolute Ratings of Environment	12
5. Electrical Characteristics.....	13
5.1 TFT LCD Module.....	13
5.2 Backlight Unit	15
6. Signal Interface Characteristic.....	16
6.1 Pixel Format Image	16
6.2 The Input Data Format	17
6.3 Integration Interface Requirement.....	18
6.4 Interface Timing	20
7. Panel Reliability Test	22
7.1 Vibration Test	22
7.2 Shock Test	22
7.3 Reliability Test.....	22
8. Mechanical Characteristics.....	23
8.1 LCM Outline Dimension.....	23
9. Shipping and Package	25
9.1 Shipping Label Format	25
9.2 Carton Package.....	26
9.3 Shipping Package of Palletizing Sequence.....	26
10. Appendix: EDID Description.....	27



Product Specification

AU OPTRONICS CORPORATION

Record of Revision

Version and Date	Page	Old description	New Description	Remark
0.1 2010/04/12	All	First Edition for Customer		
0.2 2010/4/30	24	2D Back View drawing	2D Back View drawing update	
0.3 2010/6/1	23	2D front View drawing old	2D front View drawing update	
	24	2D Back View drawing old	2D Back View drawing update	
	27	EDID : TBD	Add EDID	
1.0 2010/10/6	1	Preliminary Specification	Final Specification	
	5	Weight : TBD	Weight : 340max	
	6	Color / Chromaticity Coodinates : TBD	Color / Chromaticity Coodinates : Revise data	
	15	Backlight Power Consumption : TBD	Revise Backlight Power Consumption : 2.1	



Product Specification

AU OPTRONICS CORPORATION

1. Handling Precautions

- 1) Since front polarizer is easily damaged, pay attention not to scratch it.
- 2) Be sure to turn off power supply when inserting or disconnecting from input connector.
- 3) Wipe off water drop immediately. Long contact with water may cause discoloration or spots.
- 4) When the panel surface is soiled, wipe it with absorbent cotton or other soft cloth.
- 5) Since the panel is made of glass, it may break or crack if dropped or bumped on hard surface.
- 6) Since CMOS LSI is used in this module, take care of static electricity and insure human earth when handling.
- 7) Do not open nor modify the Module Assembly.
- 8) Do not press the reflector sheet at the back of the module to any directions.
- 9) At the insertion or removal of the Signal Interface Connector, be sure not to rotate nor tilt the Interface Connector of the TFT Module.
- 11) After installation of the TFT Module into an enclosure (Notebook PC Bezel, for example), do not twist nor bend the TFT Module even momentary. At designing the enclosure, it should be taken into consideration that no bending/twisting forces are applied to the TFT Module from outside. Otherwise the TFT Module may be damaged.
- 12) Small amount of materials having no flammability grade is used in the LCD module. The LCD module should be supplied by power complied with requirements of Limited Power Source (IEC60950 or UL1950), or be applied exemption.
- 13) Disconnecting power supply before handling LCD modules, it can prevent electric shock, DO NOT TOUCH the electrode parts, cables, connectors and LED circuit part of TFT module that a LED light bar build in as a light source of back light unit. It can prevent electronic breakdown.



Product Specification

AU OPTRONICS CORPORATION

2. General Description

B140XW03 V2 is a Color Active Matrix Liquid Crystal Display composed of a TFT LCD panel, a driver circuit, and LED backlight system. The screen format is intended to support the 16:9 HD, 1366(H) x768(V) screen and 262k colors (RGB 6-bits data driver) with LED backlight driving circuit. All input signals are LVDS interface compatible.

B140XW03 V2 is designed for a display unit of notebook style personal computer and industrial machine.

2.1 General Specification

The following items are characteristics summary on the table at 25 °C condition:

Items	Unit	Specifications			
Screen Diagonal	[mm]	354, 14.0"(13.97")			
Active Area	[mm]	309.399 x 173.952			
Pixels H x V		1366 x 3(RGB) x 768			
Pixel Pitch	[mm]	0.2265 x 0.2265			
Pixel Format		B.G.R. Vertical Stripe			
Display Mode		Normally White			
White Luminance (I _{LED} =20mA) (Note: I _{LED} is LED current)	[cd/m ²]	200 typ. (5 points average) 170 min. (5 points average)			
Luminance Uniformity		1.25 max. (5 points)			
Contrast Ratio		500 typ			
Response Time	[ms]	8 typ / 16 Max			
Nominal Input Voltage VDD	[Volt]	+3.3 typ.			
Power Consumption	[Watt]	3.0 max. (Include Logic and Blu power)			
Weight	[Grams]	340 max.			
Physical Size Include bracket	[mm]		Min.	Typ.	Max.
		Length	319.9	320.4	320.9
		Width	204.6	205.1	205.6
		Thickness	-	-	3.8
Electrical Interface		1 channel LVDS			
Glass Thickness	[mm]	0.5			
Surface Treatment		Glare, Hardness 3H,			
Support Color		262K colors (RGB 6-bit)			



Product Specification

AU OPTRONICS CORPORATION

Temperature Range Operating	[°C]	0 to +50
Storage (Non-Operating)	[°C]	-20 to +60
RoHS Compliance		RoHS Compliance

2.2 Optical Characteristics

The optical characteristics are measured under stable conditions at 25°C (Room Temperature) :

Item	Symbol	Conditions	Min.	Typ.	Max.	Unit	Note
White Luminance $I_{LED=20mA}$		5 points average	170	200	-	cd/m ²	1, 4, 5.
Viewing Angle	θ_R	Horizontal (Right) CR = 10 (Left)	65	70	-	degree	4, 9
	θ_L		65	70	-		
	ϕ_H	Vertical (Upper) CR = 10 (Lower)	55	60	-		
	ϕ_L		55	60	-		
Luminance Uniformity	δ_{5P}	5 Points	-	-	1.25		1, 3, 4
Luminance Uniformity	δ_{13P}	13 Points	-	-	1.60		2, 3, 4
Contrast Ratio	CR		400	500	-		4, 6
Cross talk	%		-	-	4		4, 7
Response Time	T_r	Rising	-	2	-	msec	4, 8
	T_f	Falling	-	6	-		
	T_{RT}	Rising + Falling	-	8	16		
Color / Chromaticity Coordinates	Red	Rx	0.558	0.588	0.618	CIE 1931	4
		Ry	0.315	0.345	0.375		
	Green	Gx	0.297	0.327	0.357		
		Gy	0.512	0.542	0.572		
	Blue	Bx	0.121	0.151	0.181		
		By	0.113	0.143	0.173		
	White	Wx	0.263	0.313	0.363		
		Wy	0.279	0.329	0.379		
NTSC	%		42	45	-		



Product Specification

AU OPTRONICS CORPORATION

Note 1: 5 points position (Ref: Active area)

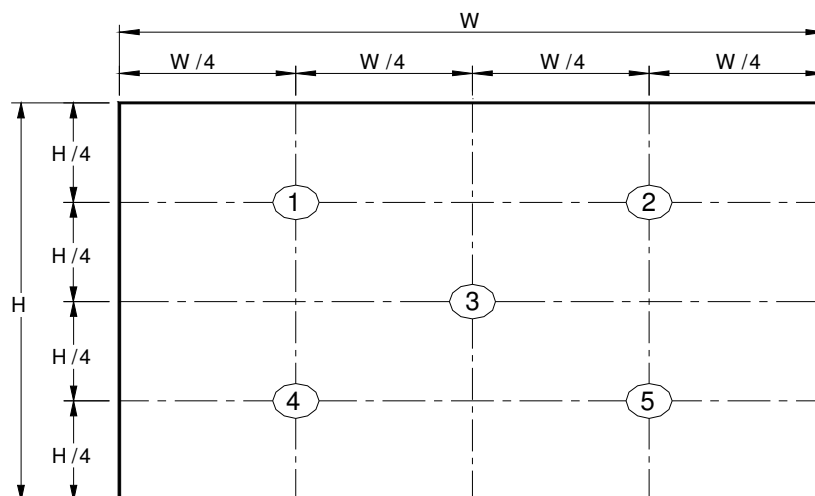

Note 2: 13 points position (Ref: Active area)

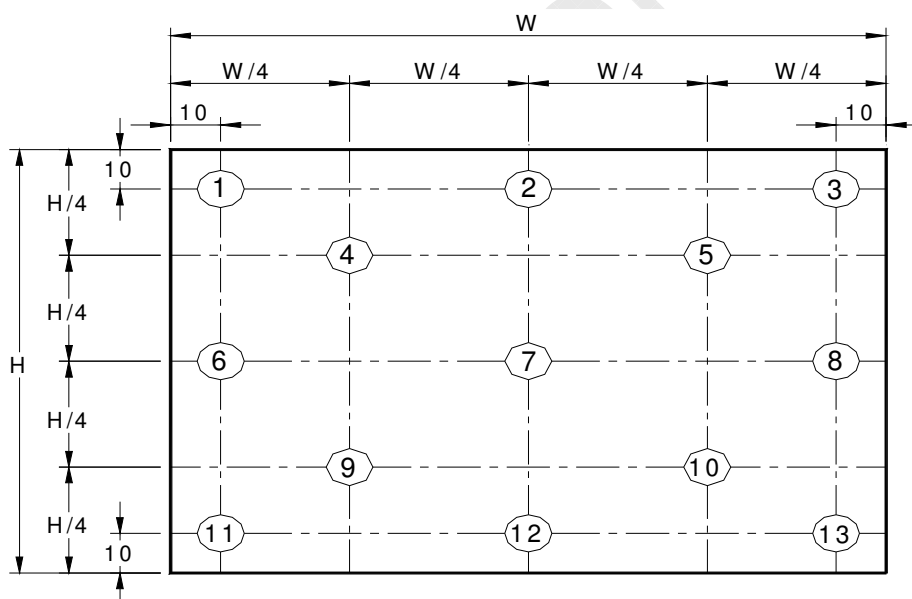

Note 3: The luminance uniformity of 5 or 13 points is defined by dividing the maximum luminance values by the minimum test point luminance

$$\delta_{W5} = \frac{\text{Maximum Brightness of five points}}{\text{Minimum Brightness of five points}}$$

$$\delta_{W13} = \frac{\text{Maximum Brightness of thirteen points}}{\text{Minimum Brightness of thirteen points}}$$

Note 4: Measurement method

The LCD module should be stabilized at given temperature for 30 minutes to avoid abrupt temperature change during measuring. In order to stabilize the luminance, the measurement should be executed after lighting



Product Specification

AU OPTRONICS CORPORATION

Backlight for 30 minutes in a stable, windless and dark room, and it should be measured in the center of screen.

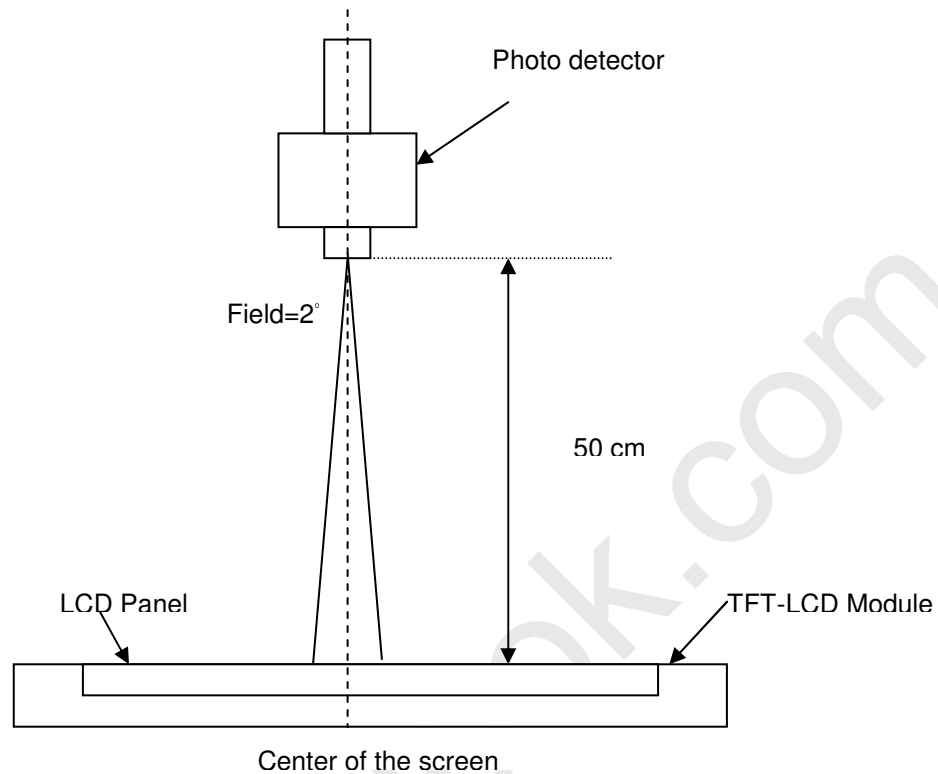

Note 5 : Definition of Average Luminance of White (Y_L):

Measure the luminance of gray level 63 at 5 points , $Y_L = [L(1) + L(2) + L(3) + L(4) + L(5)] / 5$

$L(x)$ is corresponding to the luminance of the point X at Figure in Note (1).

Note 6 : Definition of contrast ratio:

Contrast ratio is calculated with the following formula.

$$\text{Contrast ratio (CR)} = \frac{\text{Brightness on the "White" state}}{\text{Brightness on the "Black" state}}$$

Note 7 : Definition of Cross Talk (CT)

$$CT = |Y_B - Y_A| / Y_A \times 100 (\%)$$

Where

Y_A = Luminance of measured location without gray level 0 pattern (cd/m^2)

Y_B = Luminance of measured location with gray level 0 pattern (cd/m^2)



Product Specification

AU OPTRONICS CORPORATION

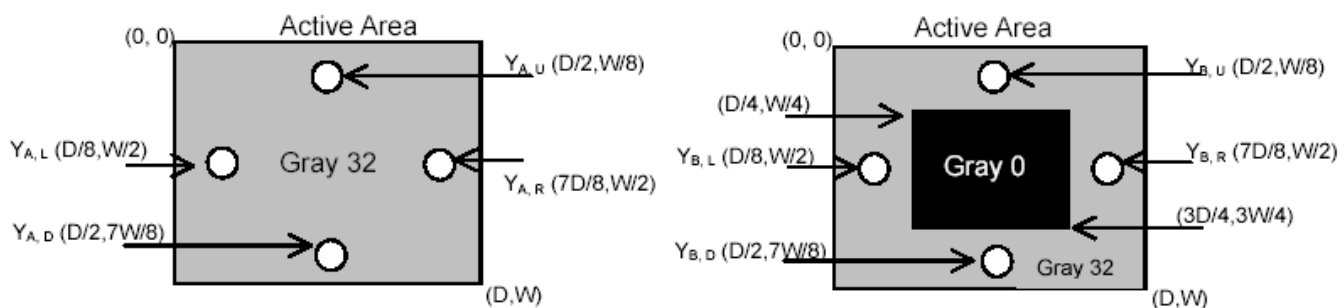

Note 8: Definition of response time:

The output signals of BM-7 or equivalent are measured when the input signals are changed from "Black" to "White" (falling time) and from "White" to "Black" (rising time), respectively. The response time interval between the 10% and 90% of amplitudes. Refer to figure as below.

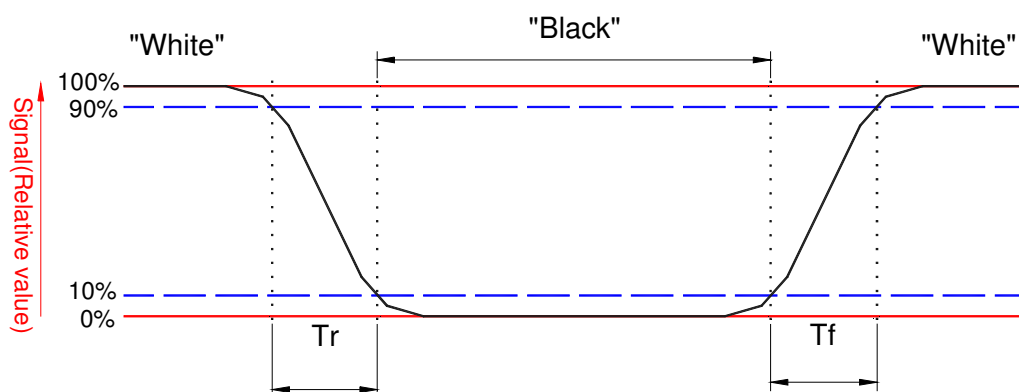



Product Specification

AU OPTRONICS CORPORATION

Note 9. Definition of viewing angle

Viewing angle is the measurement of contrast ratio ≥ 10 , at the screen center, over a 180° horizontal and 180° vertical range (off-normal viewing angles). The 180° viewing angle range is broken down as follows; 90° (θ) horizontal left and right and 90° (Φ) vertical, high (up) and low (down). The measurement direction is typically perpendicular to the display surface with the screen rotated about its center to develop the desired measurement viewing angle.

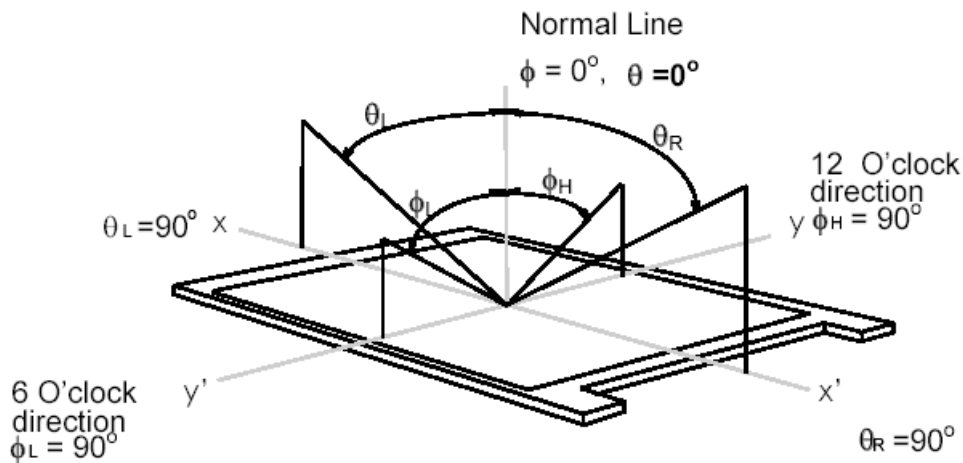



Product Specification

AU OPTRONICS CORPORATION

3. Functional Block Diagram

The following diagram shows the functional block of the 14.0 inches wide Color TFT/LCD 40 Pin one channel Module

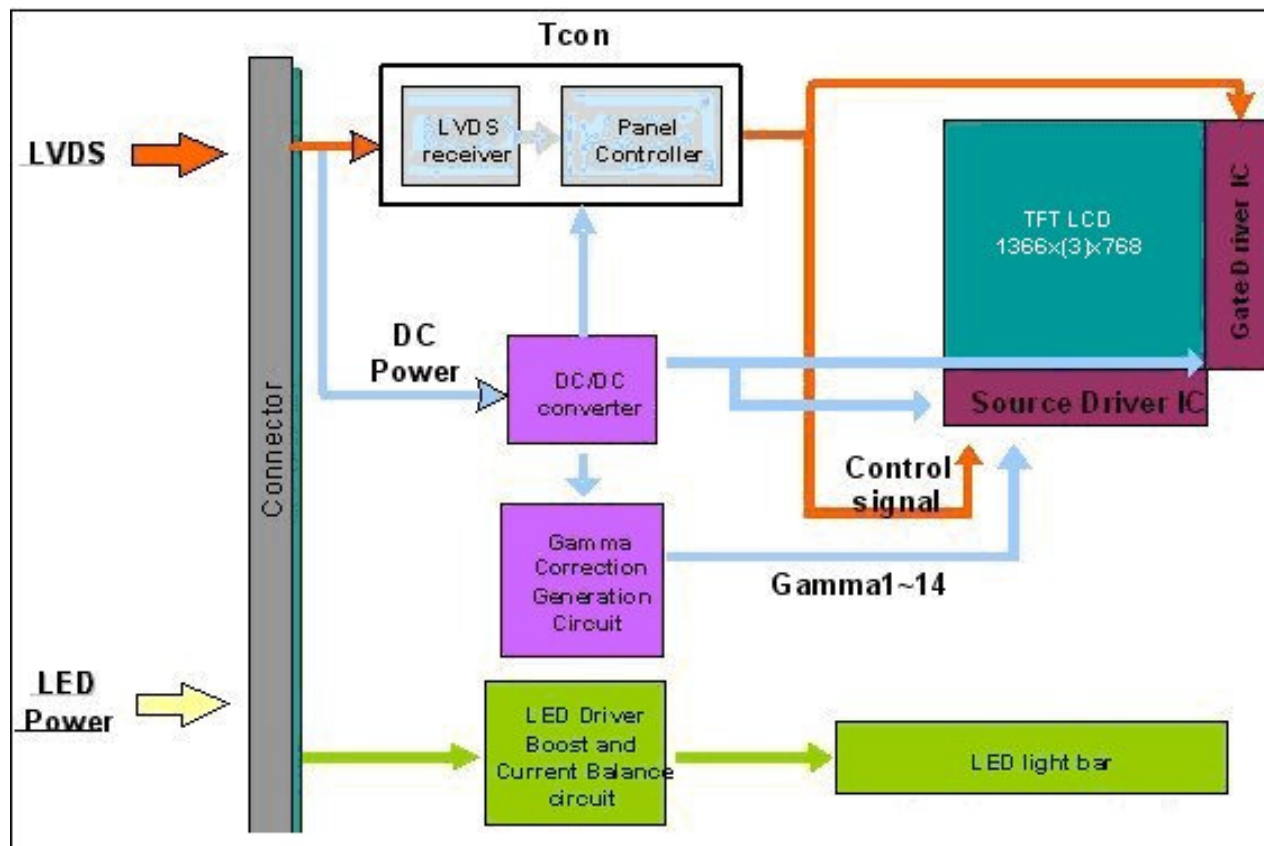



Product Specification

AU OPTRONICS CORPORATION

4. Absolute Maximum Ratings

An absolute maximum rating of the module is as following:

4.1 Absolute Ratings of TFT LCD Module

Item	Symbol	Min	Max	Unit	Conditions
Logic/LCD Drive Voltage	Vin	-0.3	+4.0	[Volt]	Note 1,2

4.2 Absolute Ratings of Environment

Item	Symbol	Min	Max	Unit	Conditions
Operating Temperature	TOP	0	+50	[°C]	Note 4
Operation Humidity	HOP	5	95	[%RH]	Note 4
Storage Temperature	TST	-20	+60	[°C]	Note 4
Storage Humidity	HST	5	95	[%RH]	Note 4

Note 1: At Ta (25°C)

Note 2: Permanent damage to the device may occur if exceed maximum values

Note 3: LED specification refer to section 5.2

Note 4: For quality performance, please refer to AUO IIS (Incoming Inspection Standard).

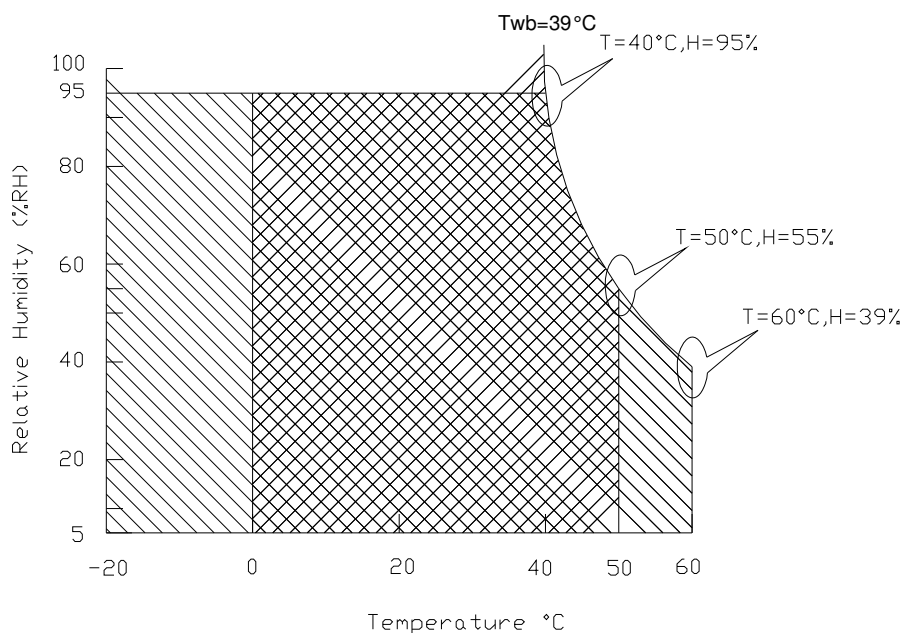

Operating Range

Storage Range +



Product Specification

AU OPTRONICS CORPORATION

5. Electrical Characteristics

5.1 TFT LCD Module

5.1.1 Power Specification

Input power specifications are as follows;

The power specification are measured under 25°C and frame frequency under 60Hz

Symble	Parameter	Min	Typ	Max	Units	Note
VDD	Logic/LCD Drive Voltage	3.0	3.3	3.6	[Volt]	
PDD	VDD Power	-	-	0.9	[Watt]	Note 1
IDD	IDD Current	-	-	333	[mA]	Note 1
IRush	Inrush Current	-	-	2000	[mA]	Note 2
VDDrp	Allowable Logic/LCD Drive Ripple Voltage	-	-	100	[mV] p-p	

Note 1 : Maximum Measurement Condition : Black Pattern at 3.3V driving voltage. ($P_{max}=V_{3.3} \times I_{black}$)

Note 2 : Measure Condition

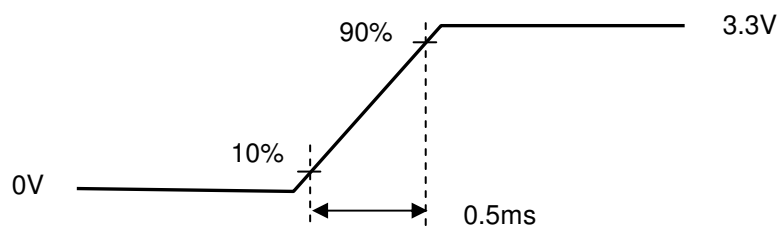
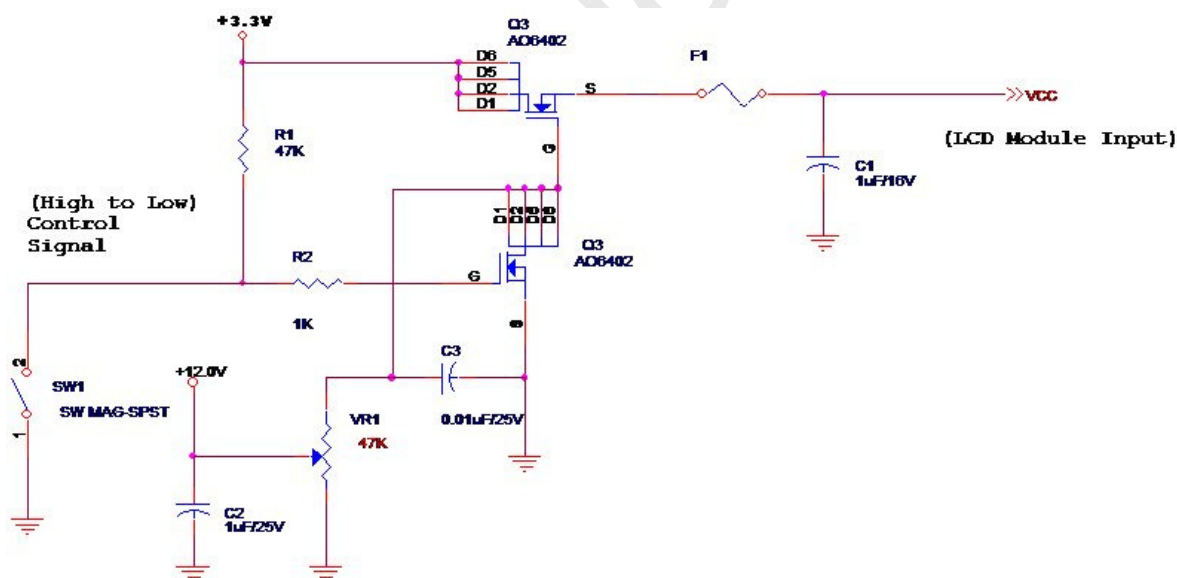

Vin rising time



Product Specification

AU OPTRONICS CORPORATION

5.1.2 Signal Electrical Characteristics

Input signals shall be low or High-impedance state when VDD is off.

Signal electrical characteristics are as follows;

Parameter	Condition	Min	Max	Unit
V_{th}	Differential Input High Threshold ($V_{cm}=+1.2V$)	-	100	[mV]
V_{tl}	Differential Input Low Threshold ($V_{cm}=+1.2V$)	-100	-	[mV]
V_{ID}	Differential Input Voltage	100	600	[mV]
V_{cm}	Differential Input Common Mode Voltage	1.125	1.375	[V]

Note: LVDS Signal Waveform

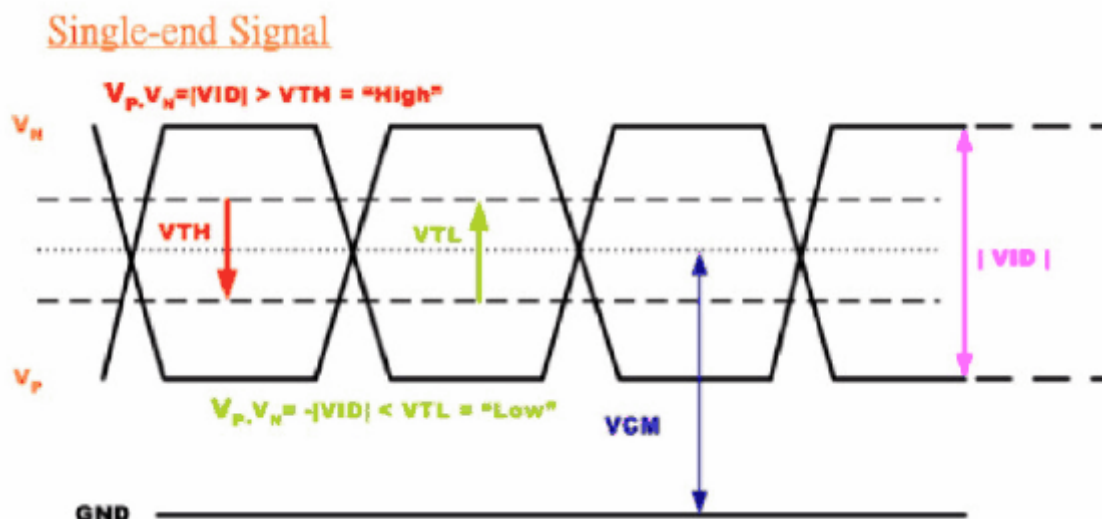



Product Specification

AU OPTRONICS CORPORATION

5.2 Backlight Unit

5.2.1 LED characteristics

Parameter	Symbol	Min	Typ	Max	Units	Condition
Backlight Power Consumption	PLED	-	-	2.1	[Watt]	(Ta=25°C), Note 1 Vin =12V
LED Life-Time	N/A	12,000	-	-	Hour	(Ta=25°C), Note 2 If=20 mA

Note 1: Calculator value for reference $P_{LED} = V_F$ (Normal Distribution) * I_F (Normal Distribution) / Efficiency

Note 2: The LED life-time define as the estimated time to 50% degradation of initial luminous.

5.2.2 Backlight input signal characteristics

Parameter	Symbol	Min	Typ	Max	Units	Remark
LED Power Supply	VLED	7.0	12.0	21.0	[Volt]	Define as Connector Interface (Ta=25°C)
LED Enable Input High Level	VLED_EN	2.5	-	5.5	[Volt]	
LED Enable Input Low Level		-	-	0.8	[Volt]	
PWM Logic Input High Level	VPWM_EN	2.5	-	5.0	[Volt]	
PWM Logic Input Low Level		-	-	0.8	[Volt]	
PWM Input Frequency	FPWM	700	1k	2K	Hz	
PWM Duty Ratio	Duty	5	--	100	%	



Product Specification

AU OPTRONICS CORPORATION

6. Signal Interface Characteristic

6.1 Pixel Format Image

Following figure shows the relationship of the input signals and LCD pixel format.

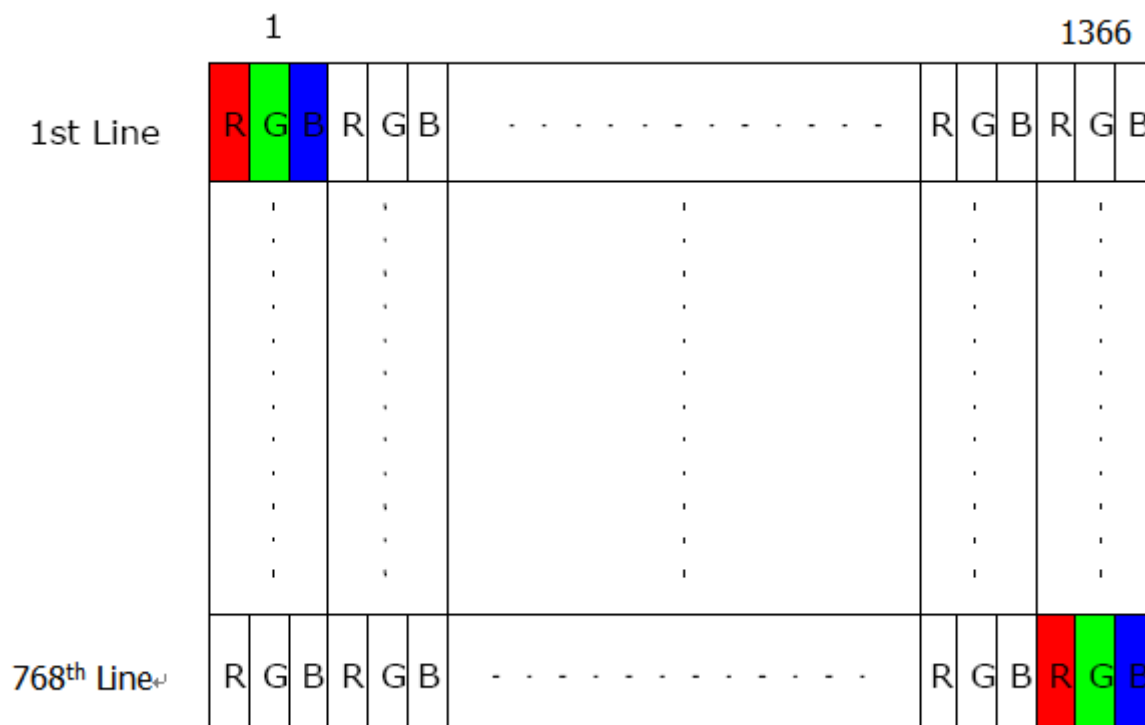



Product Specification

AU OPTRONICS CORPORATION

6.2 The Input Data Format

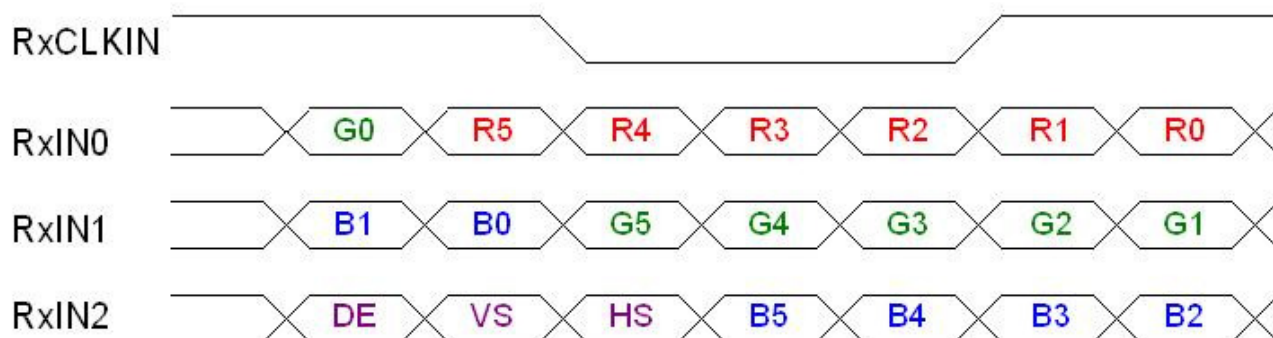

Signal Name	Description	
R5 R4 R3 R2 R1 R0	Red Data 5 (MSB) Red Data 4 Red Data 3 Red Data 2 Red Data 1 Red Data 0 (LSB)	Red-pixel Data Each red pixel's brightness data consists of these 6 bits pixel data.
G5 G4 G3 G2 G1 G0	Green Data 5 (MSB) Green Data 4 Green Data 3 Green Data 2 Green Data 1 Green Data 0 (LSB)	Green-pixel Data Each green pixel's brightness data consists of these 6 bits pixel data.
B5 B4 B3 B2 B1 B0	Blue Data 5 (MSB) Blue Data 4 Blue Data 3 Blue Data 2 Blue Data 1 Blue Data 0 (LSB)	Blue-pixel Data Each blue pixel's brightness data consists of these 6 bits pixel data.
RxCLKIN	Data Clock	The signal is used to strobe the pixel data and DE signals. All pixel data shall be valid at the falling edge when the DE signal is high.
DE	Display Timing	This signal is strobed at the falling edge of RxCLKIN. When the signal is high, the pixel data shall be valid to be displayed.
VS	Vertical Sync	The signal is synchronized to RxCLKIN .
HS	Horizontal Sync	The signal is synchronized to RxCLKIN .

Note: Output signals from any system shall be low or High-impedance state when VDD is off.



Product Specification

AU OPTRONICS CORPORATION

6.3 Integration Interface Requirement

6.3.1 Connector Description

Physical interface is described as for the connector on module.

These connectors are capable of accommodating the following signals and will be following components.

Connector Name / Designation	For Signal Connector
Manufacturer	STM
Type / Part Number	MSAK24025P40
Mating Housing/Part Number	PK24025P40

6.3.2 Pin Assignment

LVDS is a differential signal technology for LCD interface and high speed data transfer device.

B140XW03 V2		
Pin	Signal	Description
1	NC	No Connection (Reserve)
2	VDD	PowerSupply,3.3V(typical)
3	VDD	PowerSupply,3.3V(typical)
4	DVDD	DDC 3.3Vpower
5	NC	No Connection (Reserve)
6	SCL	DDC Clock
7	SDA	DDC Data
8	Rin0-	-LVDS differential data input(R0-R5,G0)
9	Rin0+	+LVDS differential data input(R0-R5,G0)
10	GND	Ground
11	Rin1-	-LVDS differential data input(G1-G5,B0-B1)
12	Rin1+	+LVDS differential data input(G1-G5,B0-B1)
13	GND	Ground
14	Rin2-	-LVDS differential data input(B2-B5,HS,VS,DE)
15	Rin2+	+LVDS differential data input(B2-B5,HS,VS,DE)
16	GND	Ground
17	ClkIN-	-LVDS differential clock input
18	ClkIN+	+LVDS differential clock input
19	CE_EN	Color Engine Control
20	NC	No Connection (Reserve)
21	NC	No Connection (Reserve)
22	GND	Ground
23	NC	No Connection (Reserve)



Product Specification

AU OPTRONICS CORPORATION

24	NC	No Connection (Reserve)
25	GND	Ground-Shield
26	NC	No Connection (Reserve)
27	NC	No Connection (Reserve)
28	GND	Ground-Shield
29	NC	No Connection (Reserve)
30	NC	No Connection (Reserve)
31	VLED_GND	LED Ground
32	VLED_GND	LED Ground
33	VLED_GND	LED Ground
34	NC	No Connection (Reserve)
35	PWM	System PWM Signal Input
36	LED_EN	LED enable pin(+3V Input)
37	ECR_EN	Dynamic Backlight Control (High Enable)
38	VLED	LED Power Supply 7V-21V
39	VLED	LED Power Supply 7V-21V
40	VLED	LED Power Supply 7V-21V

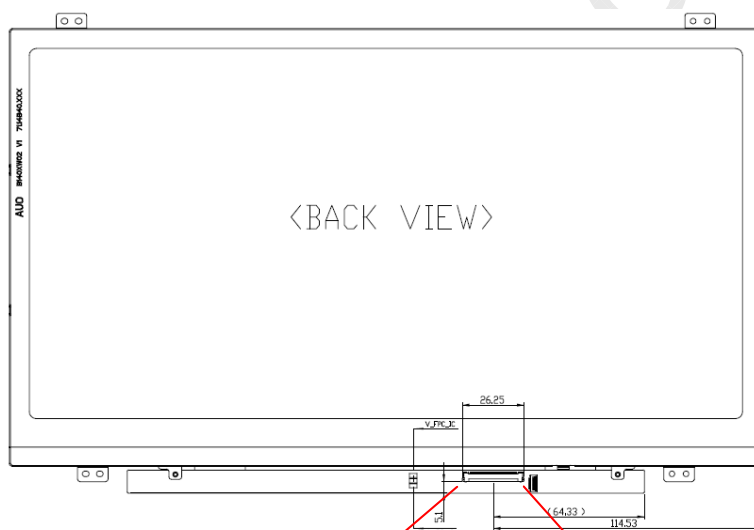

Signal Pin40

Signal Pin1

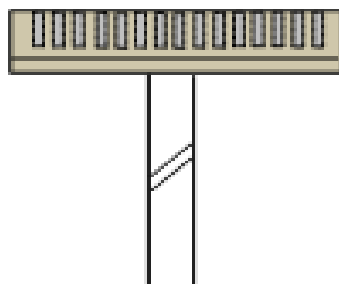
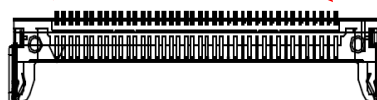

Note1: Input signals shall be low or High-impedance state when VDD is off.



Product Specification

AU OPTRONICS CORPORATION

6.4 Interface Timing

6.4.1 Timing Characteristics

Basically, interface timings should match the 1366x768 /60Hz manufacturing guide line timing.

Parameter	Symbol	Min.	Typ.	Max.	Unit	
Frame Rate	-	-	60	-	Hz	
Clock frequency	$1/T_{\text{Clock}}$	-	72	-	MHz	
Vertical Section	Period	T_V	776	808	1023	T_{Line}
	Active	T_{VD}	768			
	Blanking	T_{VB}	8	40	255	
Horizontal Section	Period	T_H	1396	1606	2047	T_{Clock}
	Active	T_{HD}	1366			
	Blanking	T_{HB}	30	240	681	

Note : DE mode only

6.4.2 Timing diagram

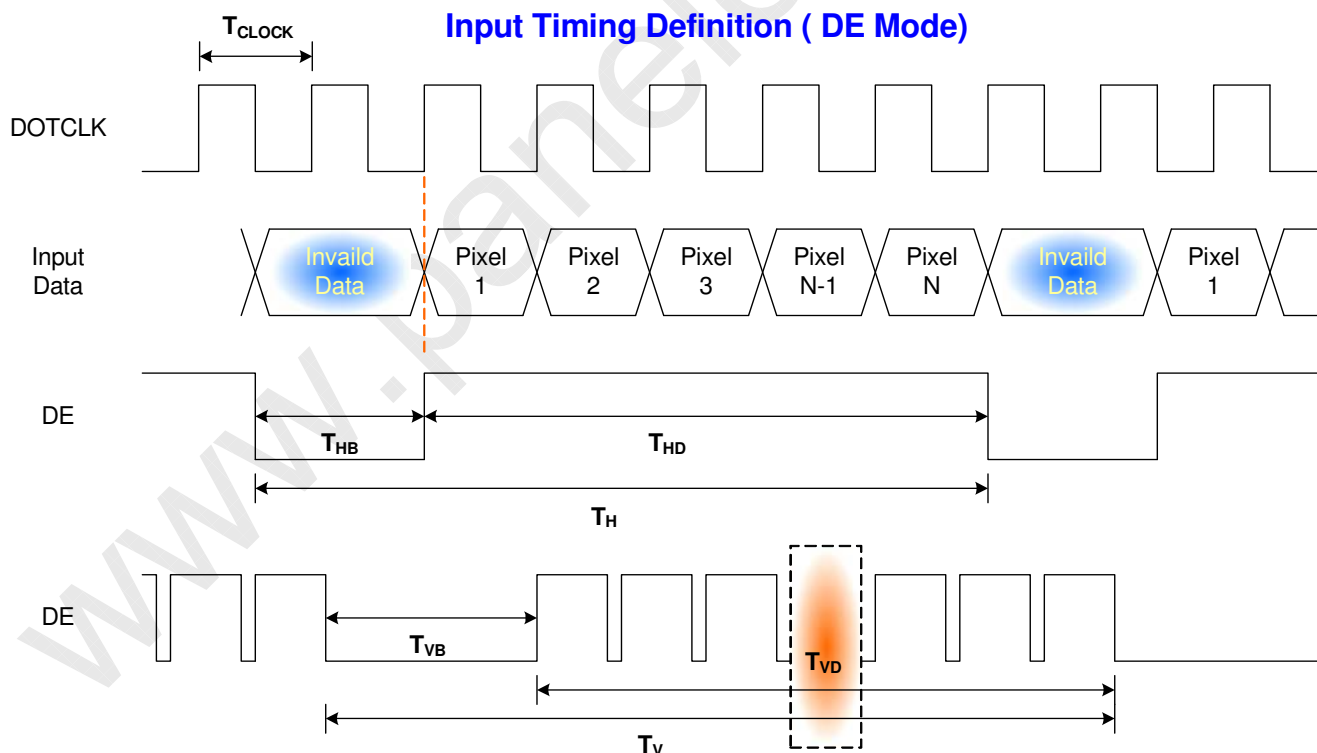



Product Specification

AU OPTRONICS CORPORATION

6.5 Power ON/OFF Sequence

Power on/off sequence is as follows. Interface signals and LED on/off sequence are also shown in the chart. Signals from any system shall be Hi-Z state or low level when VDD is off

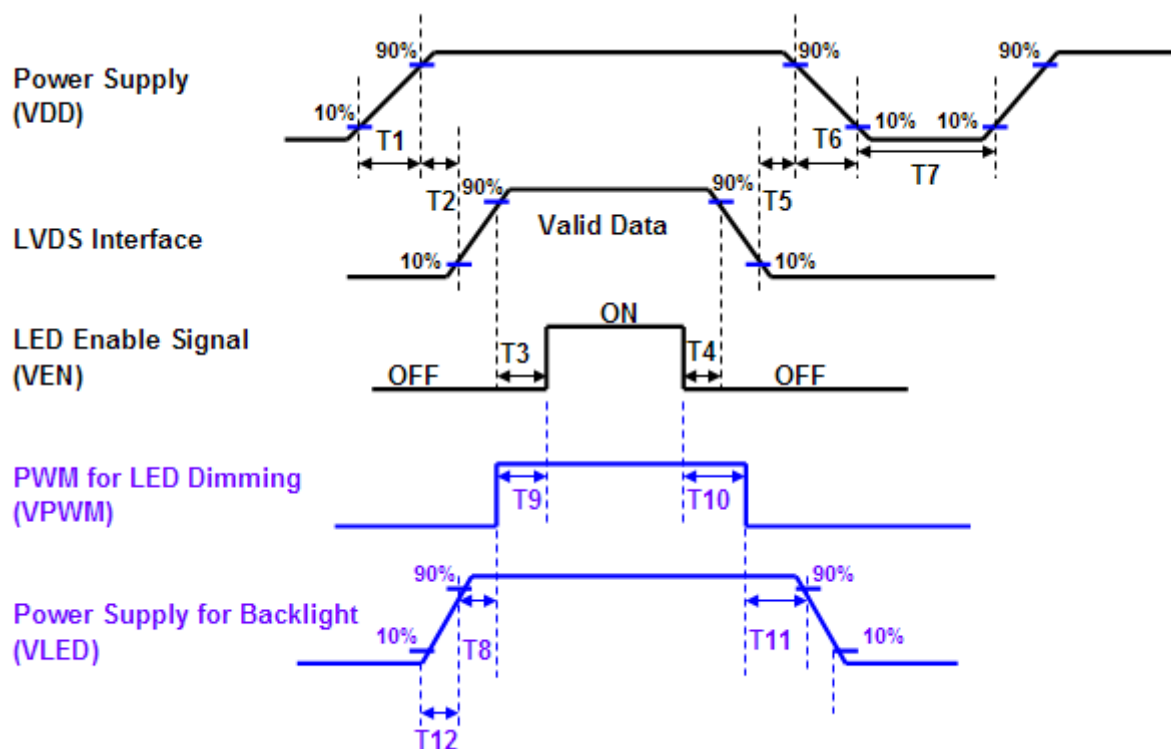

Power Sequence Timing				
Parameter	Value			Units
	Min.	Typ.	Max.	
T1	0.5	-	10	ms
T2	0	-	50	
T3	200	-	-	
T4	200	-	-	
T5	0	-	50	
T6	0	-	10	
T7	500	-	-	
T8	10	-	-	
T9	10	-	180	
T10	10	-	180	
T11	10	-	-	
T12	0.5	-	10	

Note: If T3, T5, T6 couldn't match above specifications, must request $T3+T5+T6 > 300\text{ms}$ at least



Product Specification

AU OPTRONICS CORPORATION

7. Panel Reliability Test

7.1 Vibration Test

Test Spec:

- Test method: Non-Operation
- Acceleration: 1.5 G
- Frequency: 10 - 500Hz Random
- Sweep: 30 Minutes each Axis (X, Y, Z)

7.2 Shock Test

Test Spec:

- Test method: Non-Operation
- Acceleration: 220 G , Half sine wave
- Active time: 2 ms
- Pulse: X,Y,Z .one time for each side

7.3 Reliability Test

Items	Required Condition	Note
Temperature Humidity Bias	Ta= 40°C, 90%RH, 300h	
High Temperature Operation	Ta= 50°C, Dry, 300h	
Low Temperature Operation	Ta= 0°C, 300h	
High Temperature Storage	Ta= 60°C, 35%RH, 300h	
Low Temperature Storage	Ta= -20°C, 50%RH, 250h	
Thermal Shock Test	Ta=-20°C to 60°C, Duration at 30 min, 100 cycles	
ESD	Contact : ±8 KV Air : ±15 KV	Note 1

Note1: According to EN 61000-4-2 , ESD class B: Some performance degradation allowed. No data lost
Self-recoverable. No hardware failures.

Remark: MTBF (Excluding the LED): 30,000 hours with a confidence level 90%

8. Mechanical Characteristics

8.1 LCM Outline Dimension

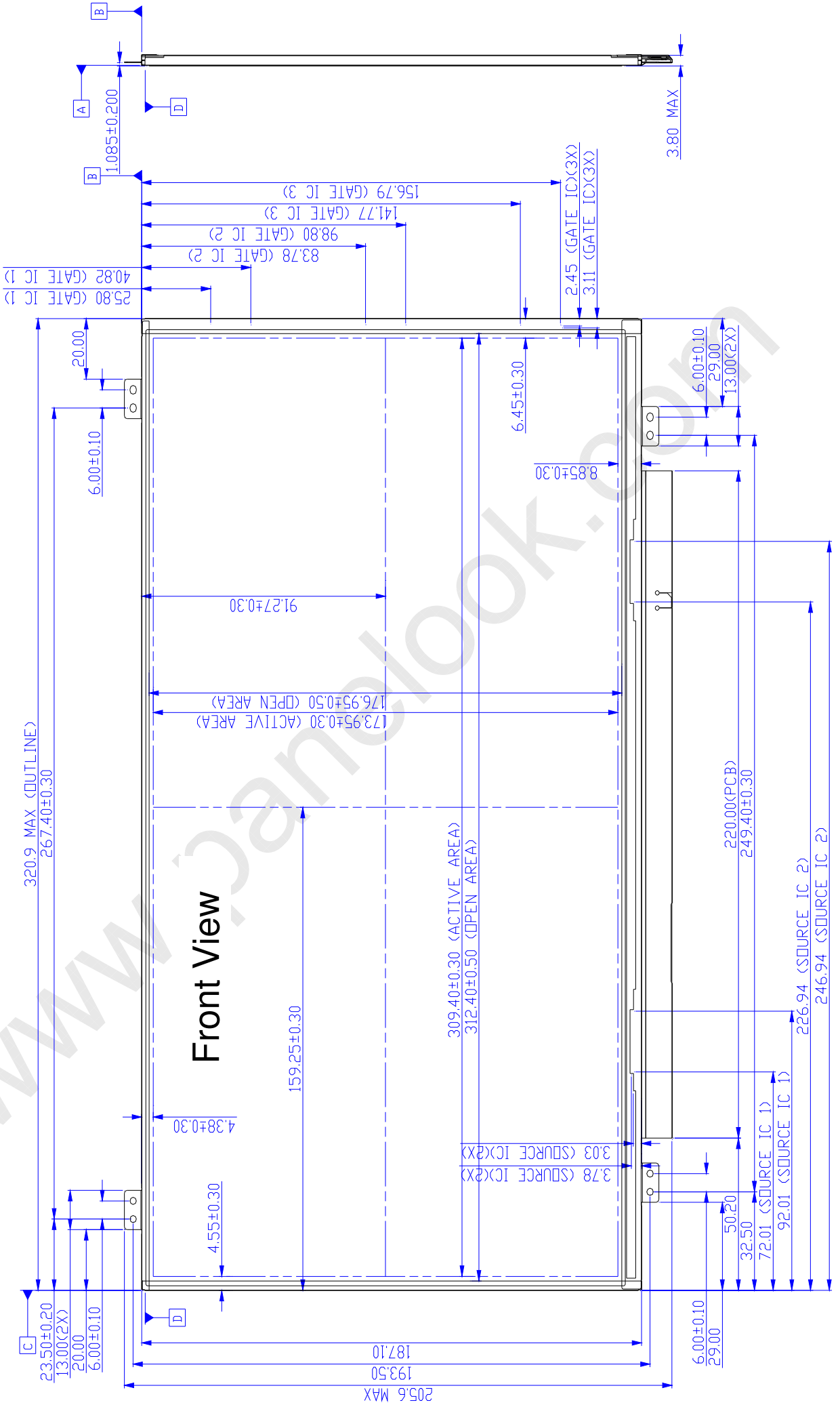

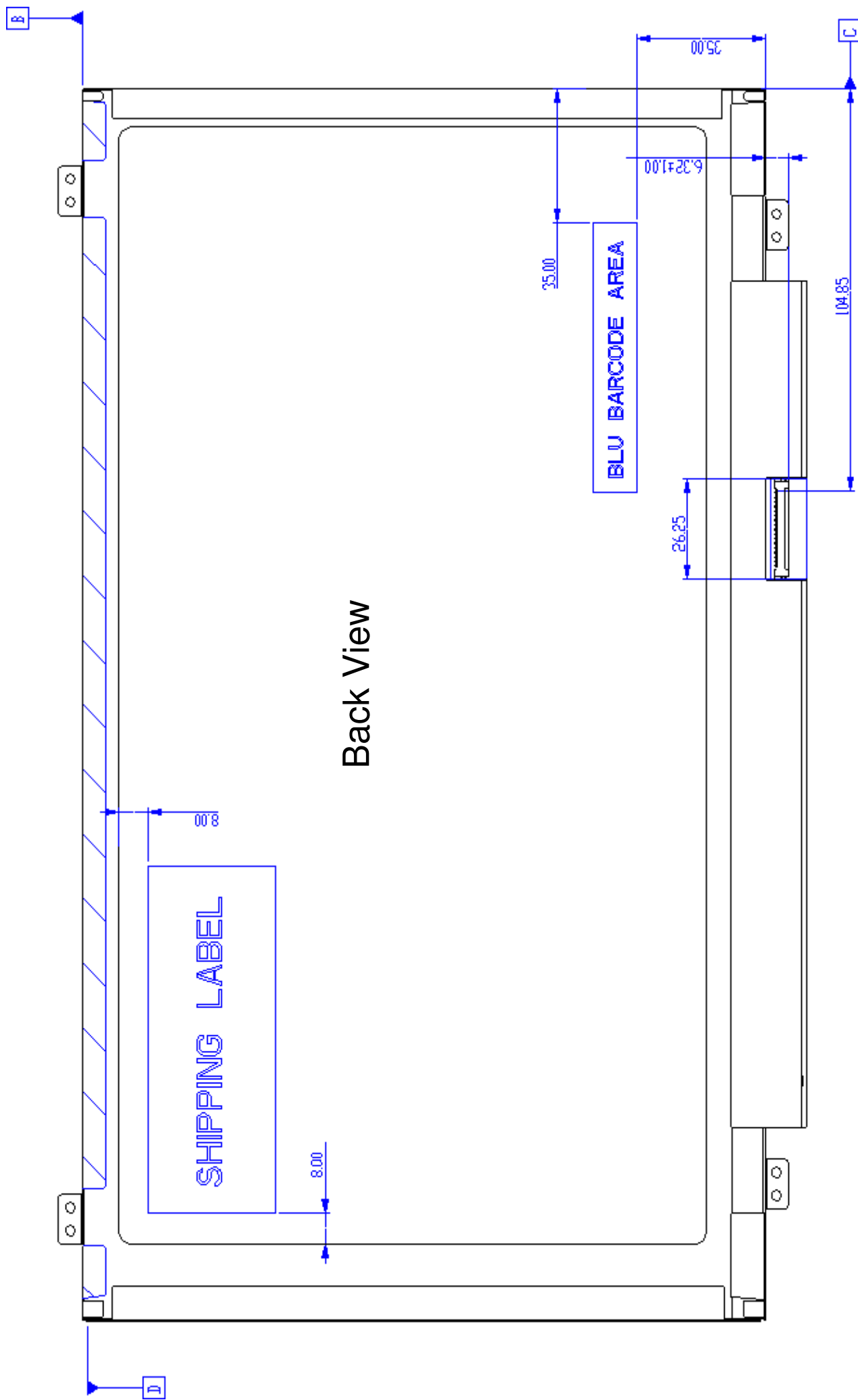

9. Shipping and Package

9.1 Shipping Label Format

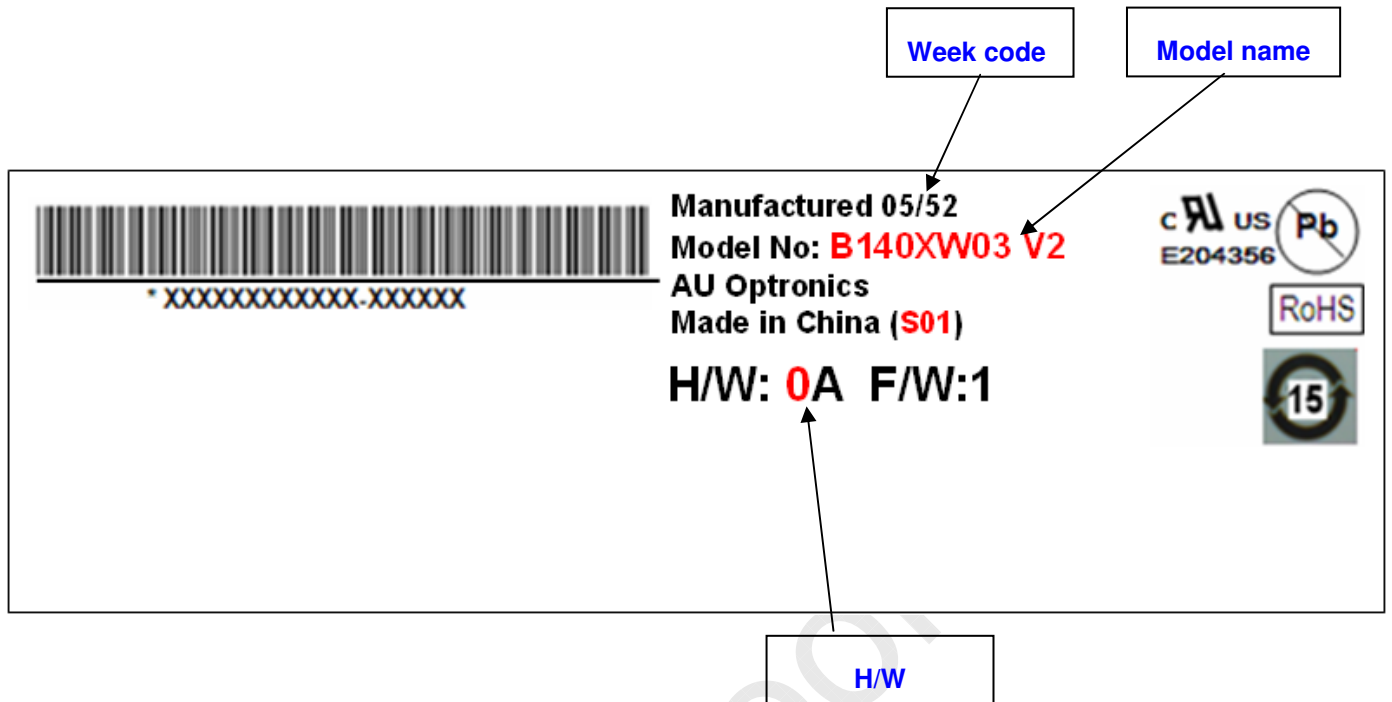

9.2 Carton Package

The outside dimension of carton is 455 (L)mm x 380 (W)mm x 355 (H)mm

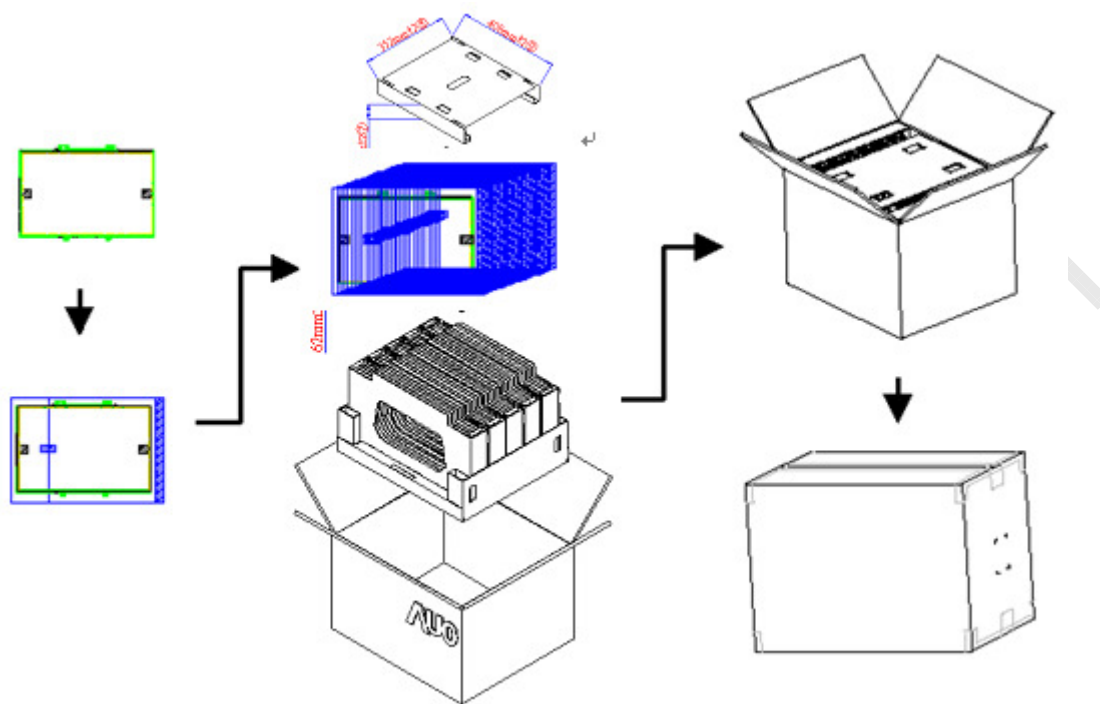

9.3 Shipping Package of Palletizing Sequence

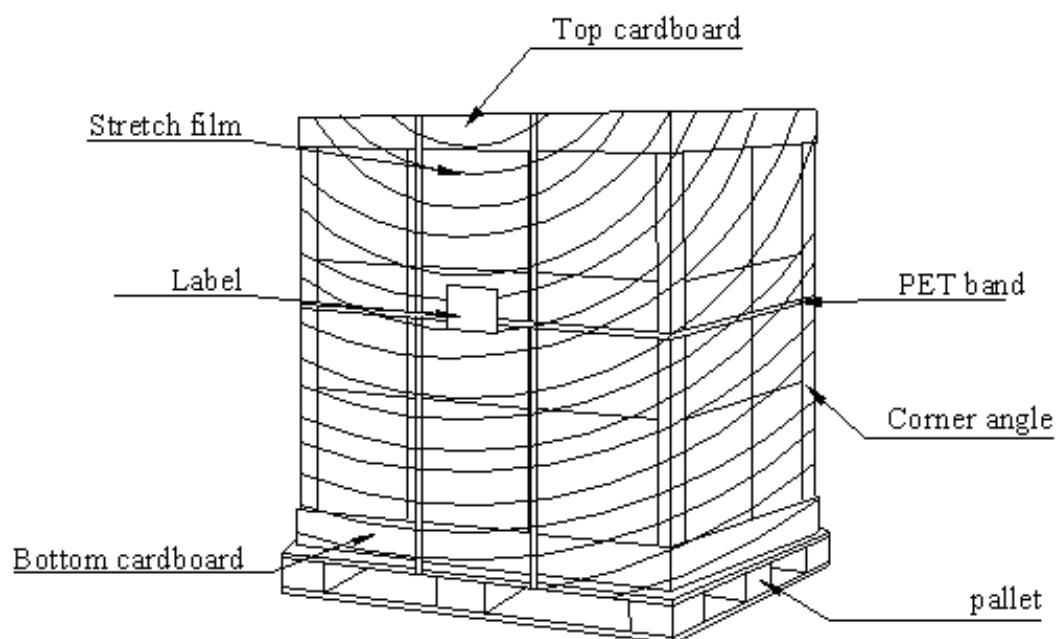

10. Appendix: EDID Description

B140XW03 V2 EDID Code

Address	FUNCTION	Value
HEX		HEX
00	Header	00
01		FF
02		FF
03		FF
04		FF
05		FF
06		FF
07		00
08	EISA Manuf. Code LSB	06
09	Compressed ASCII	AF
0A	Product Code	3C
0B	hex, LSB first	32
0C	32-bit ser #	00
0D		00
0E		00
0F		00
10	Week of manufacture	00
11	Year of manufacture	14
12	EDID Structure Ver.	01
13	EDID revision #	03
14	Video input def. (<i>digital I/P, non-TMDS, CRGB</i>)	80
15	Max H image size (<i>rounded to cm</i>)	1F
16	Max V image size (<i>rounded to cm</i>)	11
17	Display Gamma (<i>=(gamma*100)-100</i>)	78
18	Feature support (<i>no DPMS, Active OFF, RGB, tmg Blk#1</i>)	0A
19	Red/green low bits (Lower 2:2:2:2 bits)	C8
1A	Blue/white low bits (Lower 2:2:2:2 bits)	A5
1B	Red x (Upper 8 bits)	9E
1C	Red y/ highER 8 bits	57
1D	Green x	54
1E	Green y	92
1F	Blue x	26
20	Blue y	99
21	White x	50
22	White y	54
23	Established timing 1	00
24	Established timing 2	00
25	Established timing 3	00
26	Standard timing #1	01
27		01
28	Standard timing #2	01
29		01
2A	Standard timing #3	01
2B		01

2C	Standard timing #4	01
2D		01
2E	Standard timing #5	01
2F		01
30	Standard timing #6	01
31		01
32	Standard timing #7	01
33		01
34	Standard timing #8	01
35		01
36	Pixel Clock/10000 LSB	12
37	Pixel Clock/10000 USB	1B
38	Horz active Lower 8bits	56
39	Horz blanking Lower 8bits	46
3A	HorzAct:HorzBlink Upper 4:4 bits	50
3B	Vertical Active Lower 8bits	00
3C	Vertical Blanking Lower 8bits	23
3D	Vert Act : Vertical Blanking (upper 4:4 bit)	30
3E	HorzSync. Offset	26
3F	HorzSync.Width	16
40	VertSync.Offset : VertSync.Width	36
41	Horz&Vert Sync Offset/Width Upper 2bits	00
42	Horizontal Image Size Lower 8bits	35
43	Vertical Image Size Lower 8bits	AD
44	Horizontal & Vertical Image Size (upper 4:4 bits)	10
45	Horizontal Border <i>(zero for internal LCD)</i>	00
46	Vertical Border <i>(zero for internal LCD)</i>	00
47	Signal <i>(non-intr, norm, no stero, sep sync, neg pol)</i>	18
48	Detailed timing/monitor	00
49	descriptor #2	00
4A		00
4B		0F
4C		00
4D		00
4E		00
4F		00
50		00
51		00
52		00
53		00
54		00
55		00
56		00
57		00
58		00
59		20
5A	Detailed timing/monitor	00
5B	descriptor #3	00
5C		00

5D		FE
5E		00
5F	Manufacture	41
60	Manufacture	55
61	Manufacture	4F
62		0A
63		20
64		20
65		20
66		20
67		20
68		20
69		20
6A		20
6B		20
6C	Detailed timing/monitor	00
6D	descriptor #4	00
6E		00
6F		FE
70		00
71	Manufacture P/N	42
72	Manufacture P/N	31
73	Manufacture P/N	34
74	Manufacture P/N	30
75	Manufacture P/N	58
76	Manufacture P/N	57
77	Manufacture P/N	30
78	Manufacture P/N	33
79	Manufacture P/N	20
7A	Manufacture P/N	56
7B	Manufacture P/N	32
7C		20
7D		0A
7E	Extension Flag	00
7F	Checksum	01