



Product Specification

AU OPTRONICS CORPORATION

B141EW01 V5

Preliminary Specifications

Final Specifications

Module	14.1" WXGA Color TFT-LCD
Model Name	B141EW01 V5

Customer	Date
_____	_____
Checked & Approved by	
_____	_____
<p>Note: This Specification is subject to change without notice.</p>	

Approved by	Date
_____	_____
Howard Lee _____	2007/02/14 _____
Prepared by	
_____	_____
Weitse Hsu _____	2007/02/08 _____
<p>NBBU Marketing Division / AU Optronics corporation</p>	



Product Specification

AU OPTRONICS CORPORATION

B141EW01 V5

Contents

1. Handling Precautions	4
2. General Description	5
2.1 General Specification	5
2.2 Optical Characteristics	6
3. Functional Block Diagram	11
4. Absolute Maximum Ratings	12
4.1 Absolute Ratings of TFT LCD Module.....	12
4.2 Absolute Ratings of Backlight Unit	12
4.3 Absolute Ratings of Environment	12
5. Electrical characteristics	13
5.1 TFT LCD Module.....	13
5.2 Backlight Unit.....	15
6. Signal Characteristic	17
6.1 Pixel Format Image.....	17
6.2 The input data format.....	18
6.3 Signal Description/Pin Assignment	19
6.4 Interface Timing.....	21
6.5 Power ON/OFF Sequence.....	22
7. Connector Description	23
7.1 TFT LCD Module.....	23
7.2 Backlight Unit.....	23
7.3 Signal for Lamp connector	23
8. Vibration and Shock Test	24
8.1 Vibration Test	24
8.2 Shock Test Spec:	24
9. Reliability	25
10. Mechanical Characteristics	26
10.1 LCM Outline Dimension	26
10.2 Screw Hole Depth and Center Position	28
11. Shipping and Package	29
11.1 Shipping Label Format	29
11.2. Carton package	29
11.3 Shipping package of palletizing	30
12. Appendix: EDID Description	31



Product Specification

AU OPTRONICS CORPORATION

B141EW01 V5

Record of Revision

Version and Date	Page	Old description	New Description	Remark
0.0 2007/02/08	All	First Edition for Customer		



1. Handling Precautions

- 1) Since front polarizer is easily damaged, pay attention not to scratch it.
- 2) Be sure to turn off power supply when inserting or disconnecting from input connector.
- 3) Wipe off water drop immediately. Long contact with water may cause discoloration or spots.
- 4) When the panel surface is soiled, wipe it with absorbent cotton or other soft cloth.
- 5) Since the panel is made of glass, it may break or crack if dropped or bumped on hard surface.
- 6) Since CMOS LSI is used in this module, take care of static electricity and insure human earth when handling.
- 7) Do not open nor modify the Module Assembly.
- 8) Do not press the reflector sheet at the back of the module to any directions.
- 9) In case if a Module has to be put back into the packing container slot after once it was taken out from the container, do not press the center of the CCFL Reflector edge. Instead, press at the far ends of the CFL Reflector edge softly. Otherwise the TFT Module may be damaged.
- 10) At the insertion or removal of the Signal Interface Connector, be sure not to rotate nor tilt the Interface Connector of the TFT Module.
- 11) After installation of the TFT Module into an enclosure (Notebook PC Bezel, for example), do not twist nor bend the TFT Module even momentary. At designing the enclosure, it should be taken into consideration that no bending/twisting forces are applied to the TFT Module from outside. Otherwise the TFT Module may be damaged.
- 12) Cold cathode fluorescent lamp in LCD contains a small amount of mercury. Please follow local ordinances or regulations for disposal.
- 13) Small amount of materials having no flammability grade is used in the LCD module. The LCD module should be supplied by power complied with requirements of Limited Power Source(, IEC60950 or UL1950), or be applied exemption.
- 14) The LCD module is designed so that the CCFL in it is supplied by Limited Current Circuit(IEC60950 or UL1950). Do not connect the CCFL in Hazardous Voltage Circuit.



Product Specification

AU OPTRONICS CORPORATION

B141EW01 V5

2. General Description

B141EW01 V5 is a Color Active Matrix Liquid Crystal Display composed of a TFT LCD panel, a driver circuit, and backlight system. The screen format is intended to support the WXGA (1280(H) x 800(V)) screen and 262k colors (RGB 6-bits data driver). All input signals are LVDS interface compatible.

B141EW01 V5 is designed for a display unit of notebook style personal computer and industrial machine.

2.1 General Specification

The following items are characteristics summary on the table at 25 °C condition:

Items	Unit	Specifications
Screen Diagonal	[mm]	357.7 (14.1 W")
Active Area	[mm]	303.36(H) x 189.6 (V)
Pixels H x V		1280x3(RGB) x 800
Pixel Pitch	[mm]	0.237
Pixel Arrangement		R.G.B. Vertical Stripe
Display Mode		Normally White
White Luminance (ICCFL=6.0mA) Note: ICCFL is lamp current	[cd/m ²]	220 Typ. (5 points average) 190 Min. (5 points average) (Note1)
Luminance Uniformity		1.2 max. (5 points)
Contrast Ratio		350:1 Typ.,300:1 Min.
Optical Rise Time/Fall Time	[msec]	25 Typ., 35 Max.
Nominal Input Voltage VDD	[Volt]	+3.3 Typ.
Power Consumption	[Watt]	5.8 Typ. @ 6.0 mA
Weight	[Grams]	420g Typ., 440g Max.
Physical Size	[mm]	320 max. (W) x 206 max. (H) x 5.5 max.(T).
Electrical Interface		R/G/B Data, 3 Sync, Signals, Clock (4 pairs LVDS)
Surface Treatment		Haze 40, hard coating 3H, AG
Support Color		262K colors (RGB 6-bit)
Temperature Range Operating Storage (Non-Operating)	[°C] [°C]	0 to +50 -25 to +65
RoHS Compliance		RoHS Compliance



Product Specification

AU OPTRONICS CORPORATION

B141EW01 V5

2.2 Optical Characteristics

The optical characteristics are measured under stable conditions at 25°C (Room Temperature):

Item	Unit	Conditions	Min.	Typ.	Max.	Note
White Luminance I _{CCFL} =6.0mA	[cd/m ²]	5 points average	190	220	-	1, 4, 5.
Viewing Angle	[degree]	Horizontal (Right)	40	45	-	8
	[degree]	CR = 10 (Left)	40	45	-	
	[degree]	Vertical (Upper)	15	20	-	
	[degree]	CR = 10 (Lower)	30	35	-	
Luminance Uniformity		5 Points			1.20	1
Luminance Uniformity		13 Points			1.80	2
CR: Contrast Ratio			300	350	-	6
Cross talk	%				1.4	7
Response Time	[msec]	Rising	-	15	20	8
	[msec]	Falling	-	10	15	
	[msec]	Rising + Falling		25	35	
Color / Chromaticity Coordinates (CIE 1931)		Red x	0.550	0.580	0.610	2,8
		Red y	0.310	0.340	0.370	
		Green x	0.280	0.310	0.340	
		Green y	0.520	0.550	0.580	
		Blue x	0.125	0.155	0.185	
		Blue y	0.115	0.145	0.175	
		White x	0.283	0.313	0.343	
		White y	0.299	0.329	0.359	

Note 1: 5 points position (Display area : 303.36 (H) x 189.6(V)mm)

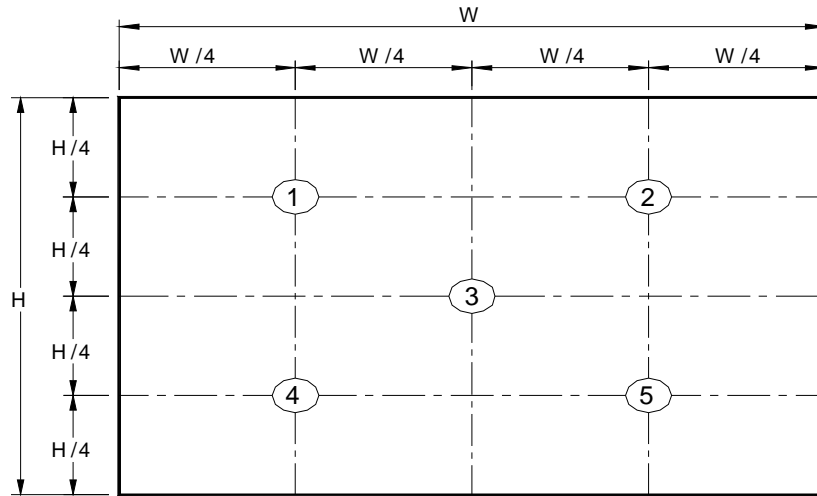

Note 2: 13 points position

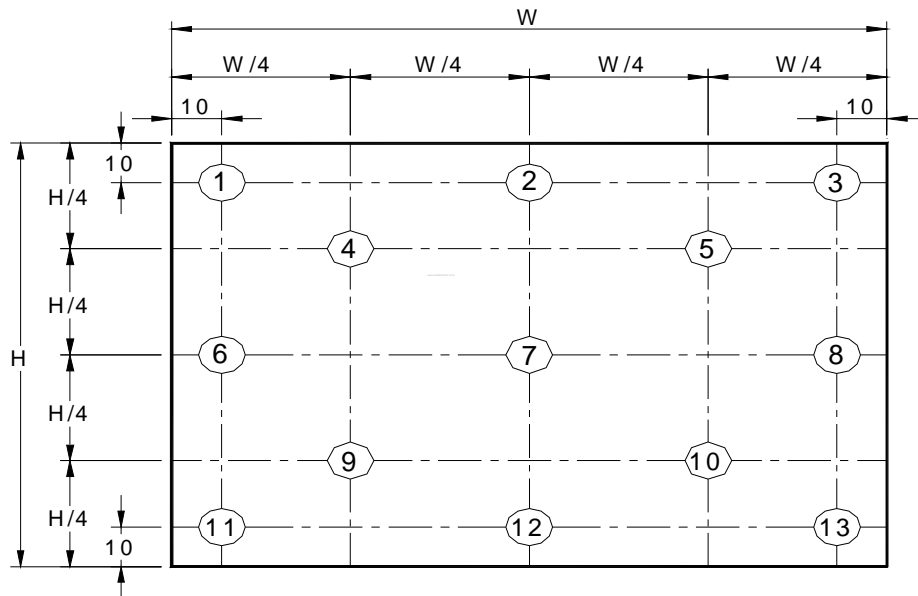

Note 3: The luminance uniformity of 5 and 13 points is defined by dividing the maximum luminance values by the minimum test point luminance

$$\delta_{W5} = \frac{\text{Maximum Brightness of five points}}{\text{Minimum Brightness of five points}}$$

$$\delta_{W13} = \frac{\text{Maximum Brightness of thirteen points}}{\text{Minimum Brightness of thirteen points}}$$

Note 4: Measurement method

The LCD module should be stabilized at given temperature for 30 minutes to avoid abrupt temperature change during measuring. In order to stabilize the luminance, the measurement should be executed after lighting Backlight for 30 minutes in a stable, windless and dark room.

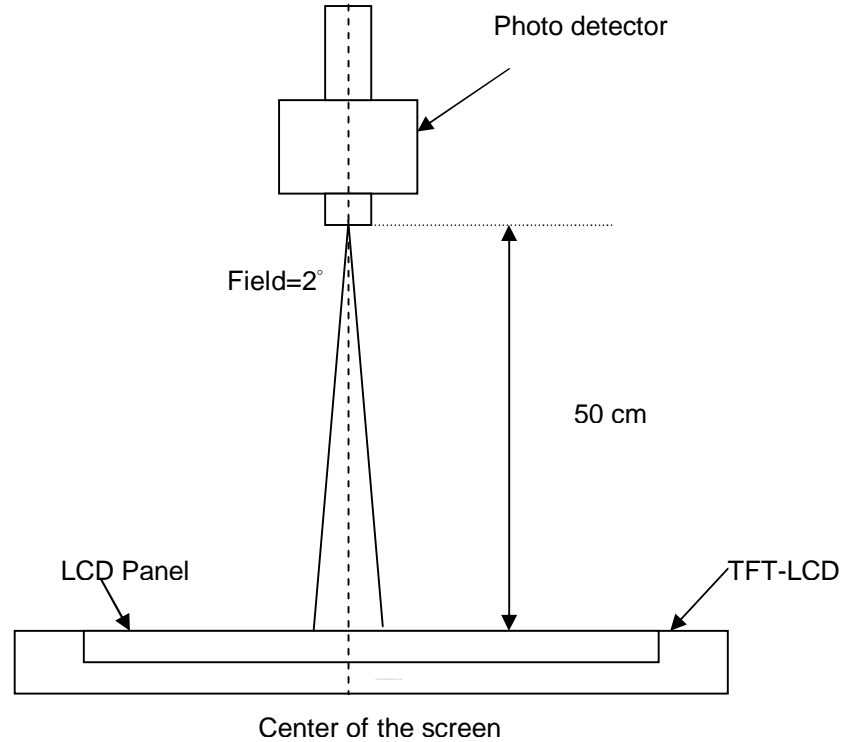

Note 5 : Definition of Average Luminance of White (Y_L):

Measure the luminance of gray level 63 at 5 points · $Y_L = [L (1)+ L (2)+ L (3)+ L (4)+ L (5)] / 5$

$L (x)$ is corresponding to the luminance of the point X at Figure in Note (1).

Note 6 : Definition of contrast ratio:

Contrast ratio is calculated with the following formula.

$$\text{Contrast ratio (CR)} = \frac{\text{Brightness on the "White" state}}{\text{Brightness on the "Black" state}}$$

Note 7 : Definition of Cross Talk (CT)

$$CT = | Y_B - Y_A | / Y_A \times 100 (\%)$$

Where

Y_A = Luminance of measured location without gray level 0 pattern (cd/m²)

Y_B = Luminance of measured location with gray level 0 pattern (cd/m²)

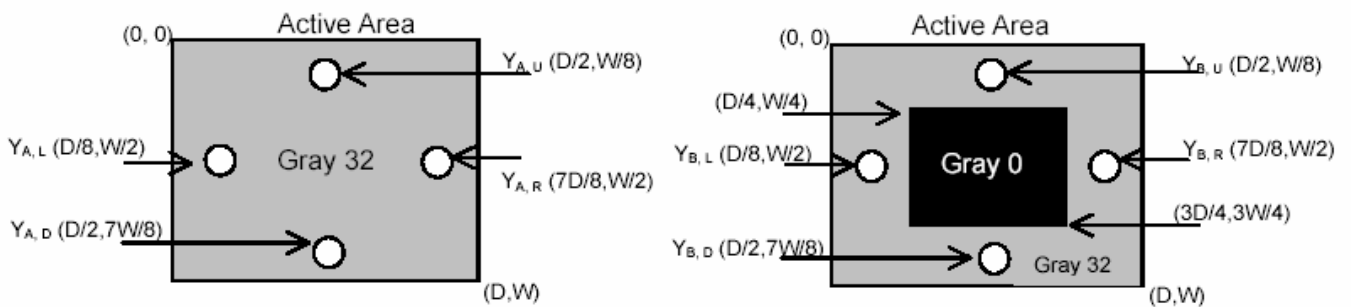

Note 8: Definition of response time:

The output signals of BM-7 or equivalent are measured when the input signals are changed from "Black" to "White" (falling time) and from "White" to "Black" (rising time), respectively. The response time interval between the 10% and 90% of amplitudes. Refer to figure as below.

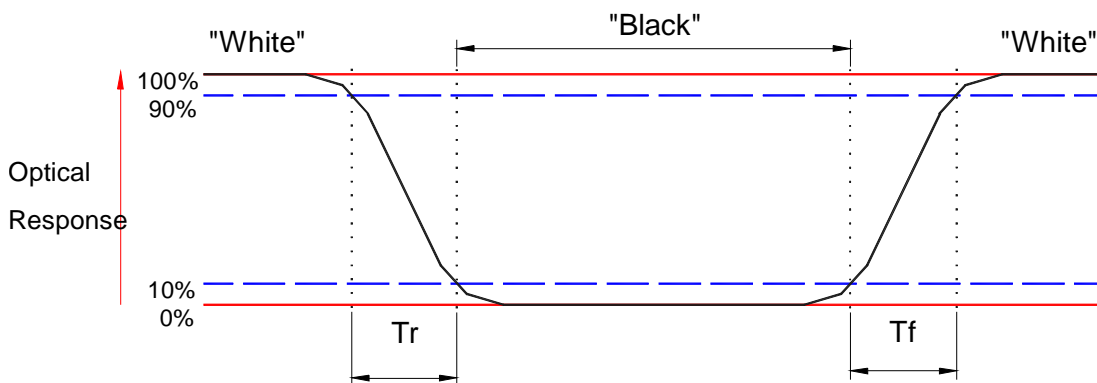

Note 9. Definition of viewing angle

Viewing angle is the measurement of contrast ratio ≥ 10 , at the screen center, over a 180° horizontal and 180° vertical range (off-normal viewing angles). The 180° viewing angle range is broken down as follows; 90° (θ) horizontal left and right and 90° (Φ) vertical, high (up) and low (down). The measurement direction is typically perpendicular to the display surface with the screen rotated about its center to develop the desired measurement viewing angle.

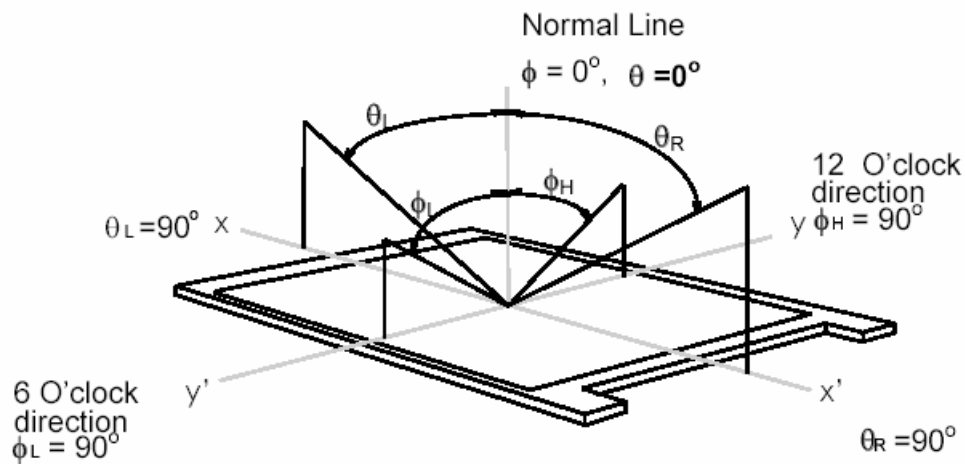

3. Functional Block Diagram

The following diagram shows the functional block of the 14.1 inches wide Color TFT/LCD Module:

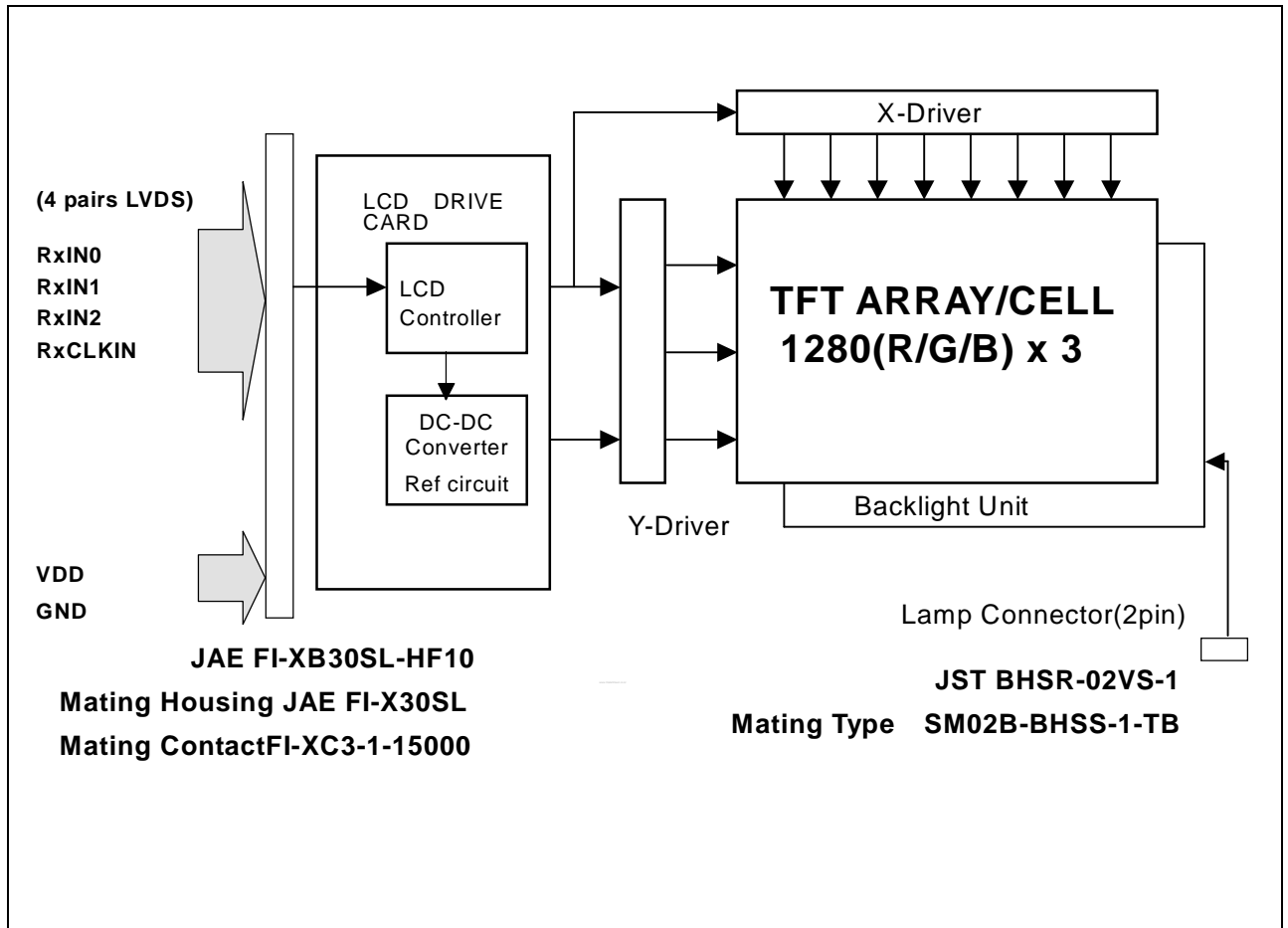

4. Absolute Maximum Ratings

Absolute maximum ratings of the module is as following:

4.1 Absolute Ratings of TFT LCD Module

Item	Symbol	Min	Max	Unit	Conditions
Logic/LCD Drive	VDD	-0.3	+4.0	[Volt]	Note 1,2

4.2 Absolute Ratings of Backlight Unit

Item	Symbol	Min	Max	Unit	Conditions
CCFL Current	ICFL	2.5	7.0	[mA] rms	Note 1,2

4.3 Absolute Ratings of Environment

Item	Symbol	Min	Max	Unit	Conditions
Operating Temperature	TOP	0	+50	[°C]	Note 3
Operation Humidity	HOP	5	95	[%RH]	Note 3
Storage Temperature	TST	-25	+65	[°C]	Note 3
Storage Humidity	HST	5	95	[%RH]	Note 3

Note 1: At Ta (25°C)

Note 2: Permanent damage to the device may occur if exceed maximum values

Note 3: For quality performance, please refer to AUO IIS(Incoming Inspection Standard).

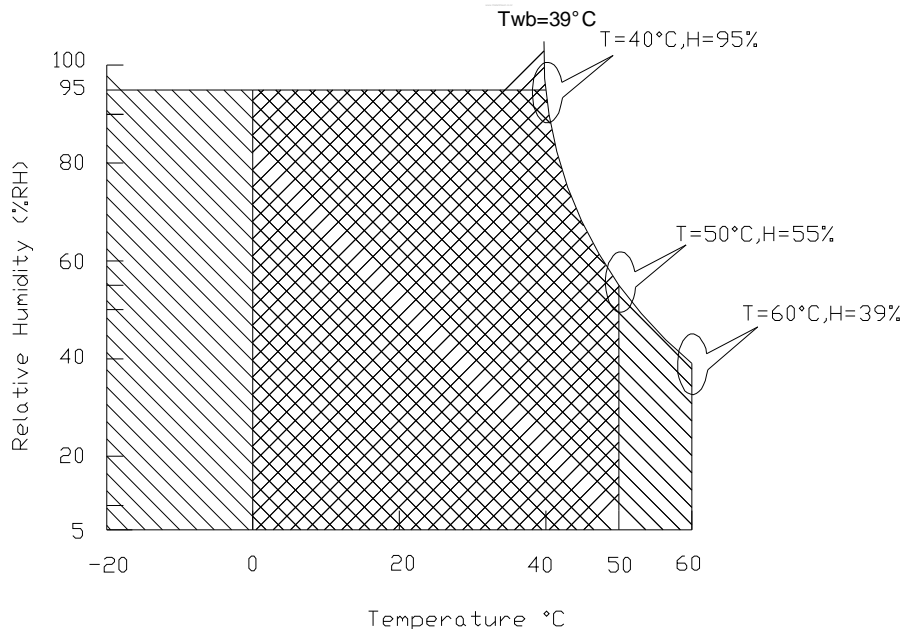

Operating Range



Storage Range



5. Electrical characteristics

5.1 TFT LCD Module

5.1.1 Power Specification

Input power specifications are as follows;

Symble	Parameter	Min	Typ	Max	Units	Note
VDD	Logic/LCD Drive Voltage	3.0	3.3	3.6	[Volt]	
PDD	VDD Power		1.2		[Watt]	Note 1
IDD	IDD Current		360		[mA]	Note 1
IRush	Inrush Current			1200	[mA]	Note 2
VDDrp	Allowable Logic/LCD Drive Ripple Voltage			100	[mV] p-p	

Note 1 : Maximum Measurement Condition : Black Patternm

Note 2 : Measure Condition

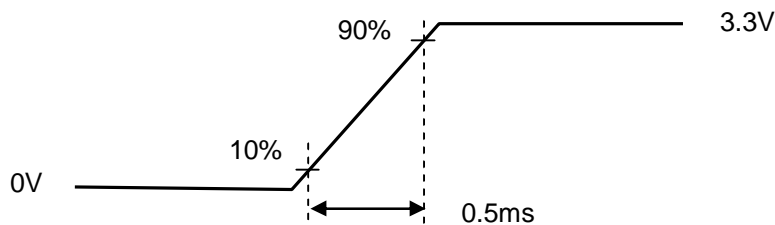
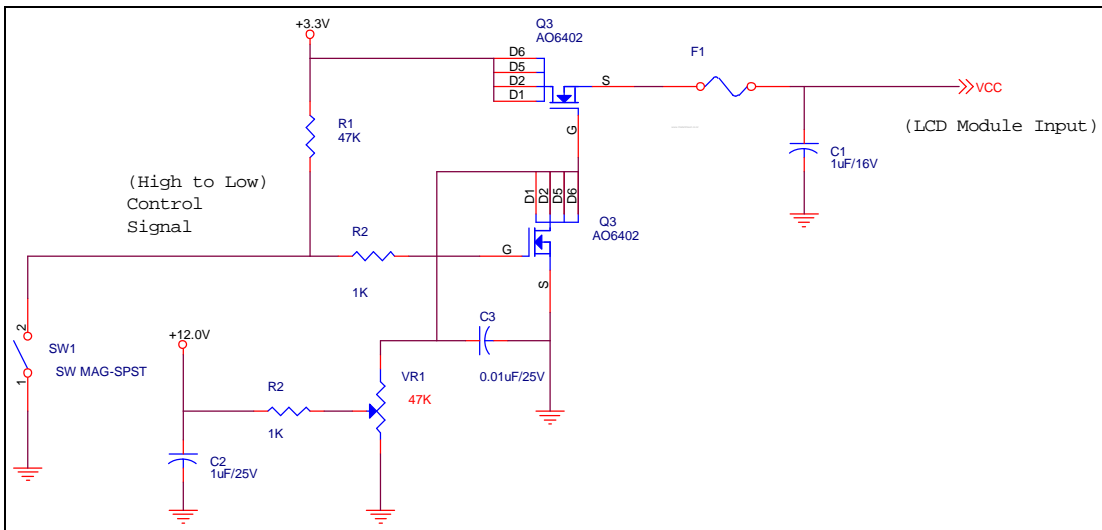

Vin rising time

5.1.2 Signal Electrical Characteristics

Input signals shall be low or High-impedance state when VDD is off.

Signal electrical characteristics are as follows;

Parameter	Condition	Min	Max	Unit
Vth	Differential Input High Threshold (Vcm=+1.2V)		100	[mV]
Vtl	Differential Input Low Threshold (Vcm=+1.2V)	-100		[mV]
Vcm	Differential Input Common Mode Voltage	1.125	1.375	[V]

Note: LVDS Differential Voltage

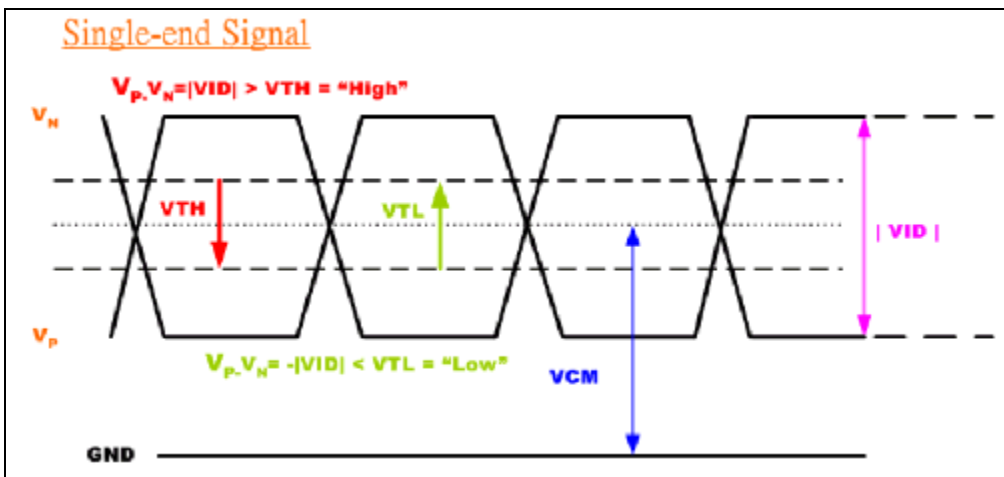



Product Specification

AU OPTRONICS CORPORATION

B141EW01 V5

5.2 Backlight Unit

Parameter guideline for CCFL Inverter

Parameter	Min	Typ	Max	Units	Condition
White Luminance 5 points average	190	220	-	[cd/m ²]	(Ta=25°C)
CCFL current(ICCFL)	2.5	6.0	7.0	[mA] rms	(Ta=25°C) Note 2
CCFL Frequency(FCCFL)	50	60	65	[KHz]	(Ta=25°C) Note 3,4
CCFL Ignition Voltage(Vs)			1440	[Volt] rms	(Ta= 0°C) Note 5
CCFL Ignition Voltage(Vs)		1000	1200	[Volt] rms	(Ta= 25°C) Note 5
CCFL Voltage (Reference) (VCCFL)		650		[Volt] rms	(Ta=25°C) Note 6
CCFL Power consumption (PCCFL) @ 6.0 mA	-	4.6		[Watt]	(Ta=25°C) Note 6

Note 1: Typ are AUO recommended Design Points.

*1 All of characteristics listed are measured under the condition using the AUO Test inverter.

*2 In case of using an inverter other than listed, it is recommended to check the inverter carefully.

Sometimes, interfering noise stripes appear on the screen, and substandard luminance or flicker at low power may happen.

*3 In designing an inverter, it is suggested to check safety circuit very carefully. Impedance of CCFL, for instance, becomes more than 1 [M ohm] when CFL is damaged.

*4 Generally, CCFL has some amount of delay time after applying kick-off voltage. It is recommended to keep on applying kick-off voltage for 1 [Sec] until discharge.

*5 CCFL discharge frequency must be carefully chosen so as not to produce interfering noise stripes on the screen.

*6 Reducing CCFL current increases CCFL discharge voltage and generally increases CCFL discharge frequency. So all the parameters of an inverter should be carefully designed so as not to produce too much leakage current from high-voltage output of the inverter.

Note 2: It should be employed the inverter which has "Duty Dimming", if ICCFL is less than 4mA.

Note 3: CCFL discharge frequency should be carefully determined to avoid interference between inverter and TFT LCD.

Note 4: The frequency range will not affect to lamp life and reliability characteristics.

Note 5: CCFL inverter should be able to give out a power that has a generating capacity of over 1,430 voltage. Lamp units need 1,400 voltage minimum for ignition.

Note 6: Calculator value for reference ($I_{CCFL} \times V_{CCFL} = P_{CCFL}$)

Note 7: Requirements for a system inverter design, which is intended to have a better display performance, a better power efficiency and a more reliable lamp, are following.

It shall help increase the lamp lifetime and reduce leakage current.

- a. The asymmetry rate of the inverter waveform should be less than 10%.
- b. The distortion rate of the waveform should be within $\sqrt{2} \pm 10\%$.

* Inverter output waveform had better be more similar to ideal sine wave.

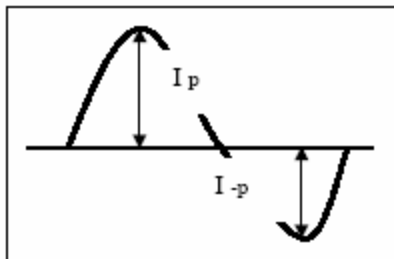

* Asymmetry rate:

$$\frac{|I_p - I_{-p}|}{I_{rms}} * 100\%$$

* Distortion rate

$$I_p \text{ (or } I_{-p}) / I_{rms}$$



Product Specification

AU OPTRONICS CORPORATION

B141EW01 V5

6. Signal Characteristic

6.1 Pixel Format Image

Following figure shows the relationship of the input signals and LCD pixel format.

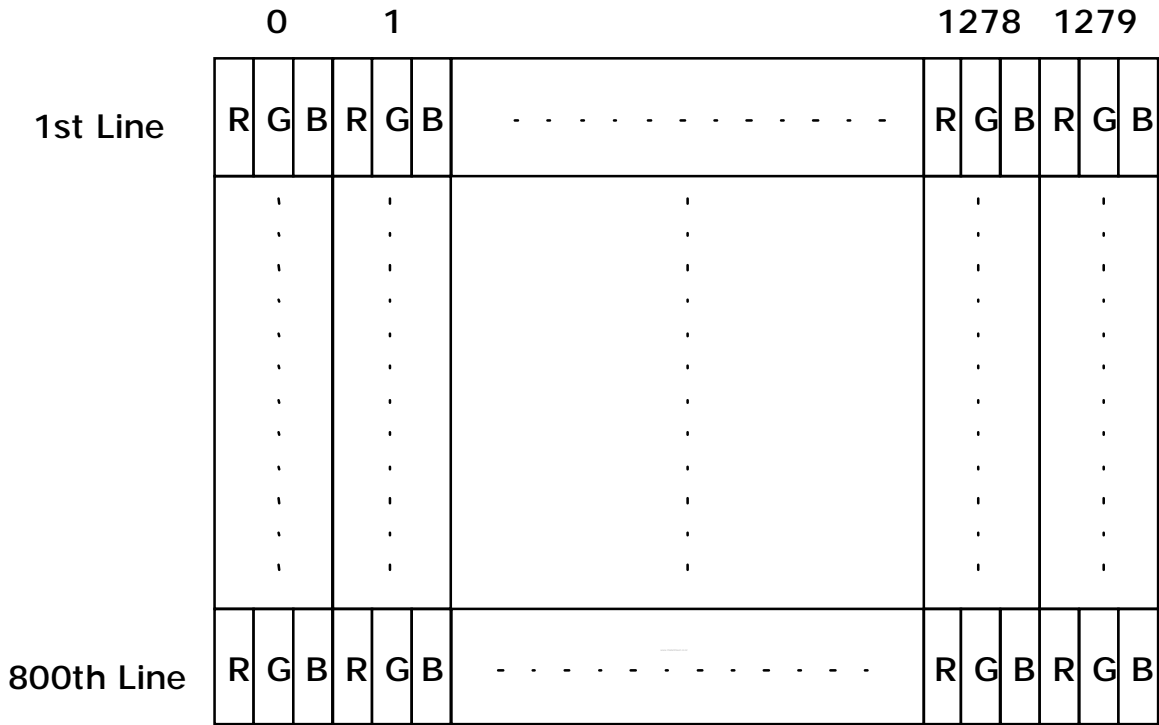



Product Specification

AU OPTRONICS CORPORATION

B141EW01 V5

6.2 The input data format

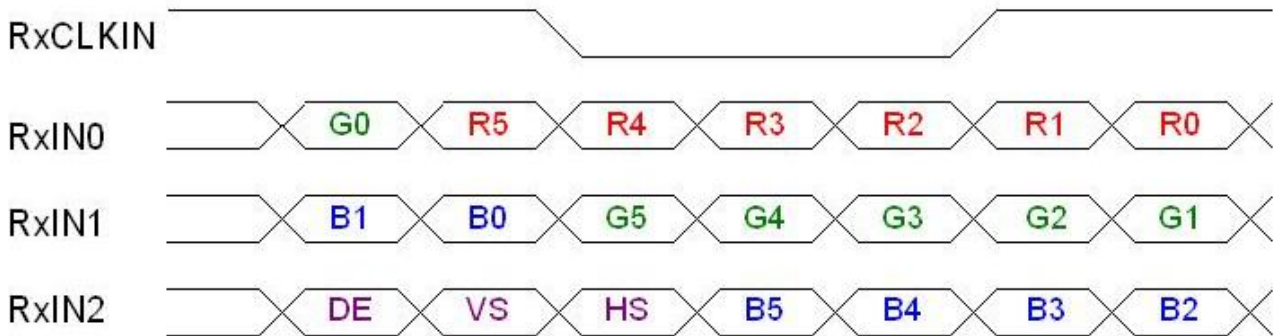

Signal Name	Description	
+RED5 (R5) +RED4 (R4) +RED3 (R3) +RED2 (R2) +RED1 (R1) +RED0 (R0)	Red Data 5 (MSB) Red Data 4 Red Data 3 Red Data 2 Red Data 1 Red Data 0 (LSB) (Red-pixel Data)	Red-pixel Data Each red pixel's brightness data consists of these 6 bits pixel data.
+GREEN 5 (G5) +GREEN 4 (G4) +GREEN 3 (G3) +GREEN 2 (G2) +GREEN 1 (G1) +GREEN 0 (G0)	Green Data 5 (MSB) Green Data 4 Green Data 3 Green Data 2 Green Data 1 Green Data 0 (LSB) (Green-pixel Data)	Green-pixel Data Each green pixel's brightness data consists of these 6 bits pixel data.
+BLUE 5 (B5) +BLUE 4 (B4) +BLUE 3 (B3) +BLUE 2 (B2) +BLUE 1 (B1) +BLUE 0 (B0)	Blue Data 5 (MSB) Blue Data 4 Blue Data 3 Blue Data 2 Blue Data 1 Blue Data 0 (LSB) (Blue-pixel Data)	Blue-pixel Data Each blue pixel's brightness data consists of these 6 bits pixel data.
-DTCLK	Data Clock	The typical frequency is 71.1 MHz. The signal is used to strobe the pixel data and DSPTMG signals. All pixel data shall be valid at the falling edge when the DSPTMG signal is high.
DSPTMG (DE)	Display Timing	This signal is stored at the falling edge of -DTCLK. When the signal is high, the pixel data shall be valid to be displayed.
VSUNC (VS)	Vertical Sync	The signal is synchronized to -DTCLK .
HSUNC (HS)	Horizontal Sync	The signal is synchronized to -DTCLK .

Note: Output signals from any system shall be low or High-impedance state when VDD is off.



Product Specification

AU OPTRONICS CORPORATION

B141EW01 V5

6.3 Signal Description/Pin Assignment

LVDS is a differential signal technology for LCD interface and high speed data transfer device.

Pin#	Signal Name	Pin#	Signal Name
1	GND	2	VDD
3	VDD	4	V _{EDID}
5	Aging	6	CLK _{EDID}
7	DATA _{EDID}	8	RxIN0-
9	RxIN0+	10	GND
11	RxIN1-	12	RxIN1+
13	GND	14	RxIN2-
15	RxIN2+	16	GND
17	RxCLKIN-	18	RxCLKIN+
19	GND	20	NC
21	NC	22	GND
23	NC	24	NC
25	GND	26	NC
27	NC	28	GND
29	NC	30	NC

Note1: Start from right side

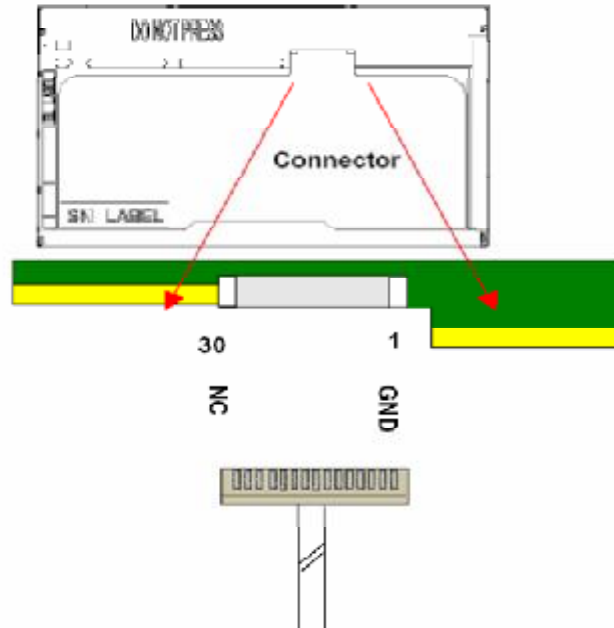

Note2: Input signals shall be low or High-impedance state when VDD is off.
internal circuit of LVDS inputs are as following.

The module uses a 100ohm resistor between positive and negative data lines of each receiver input

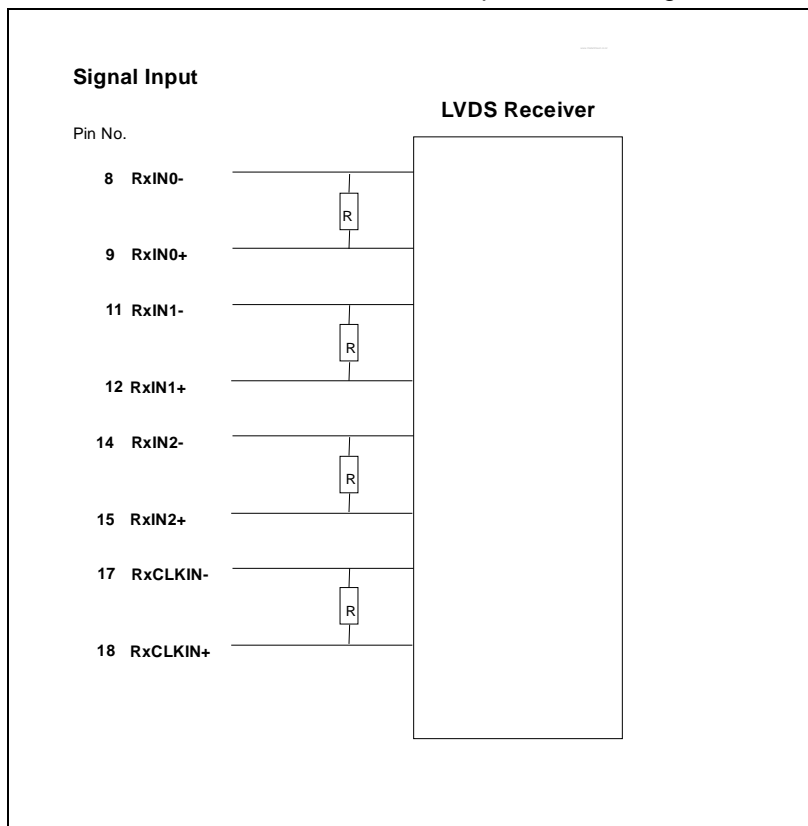

6.4 Interface Timing

6.4.1 Timing Characteristics

Basically, interface timings should match the 1280x800 /60Hz manufacturing guide line timing.

Parameter	Symbol	Min.	Typ.	Max.	Unit	
Frame Rate	-		60	-	Hz	
Clock frequency	$1/T_{\text{Clock}}$		71.1		MHz	
Vertical Section	Period	T_V	803	823	1023	T_{Line}
	Active	T_{VD}	800	800	800	
	Blanking	T_{VB}	3	23	223	
Horizontal Section	Period	T_H	1303	1440	2047	T_{Clock}
	Active	T_{HD}	1280	1280	1280	
	Blanking	T_{HB}	23	160	767	

Note : DE mode only

6.4.2 Timing diagram

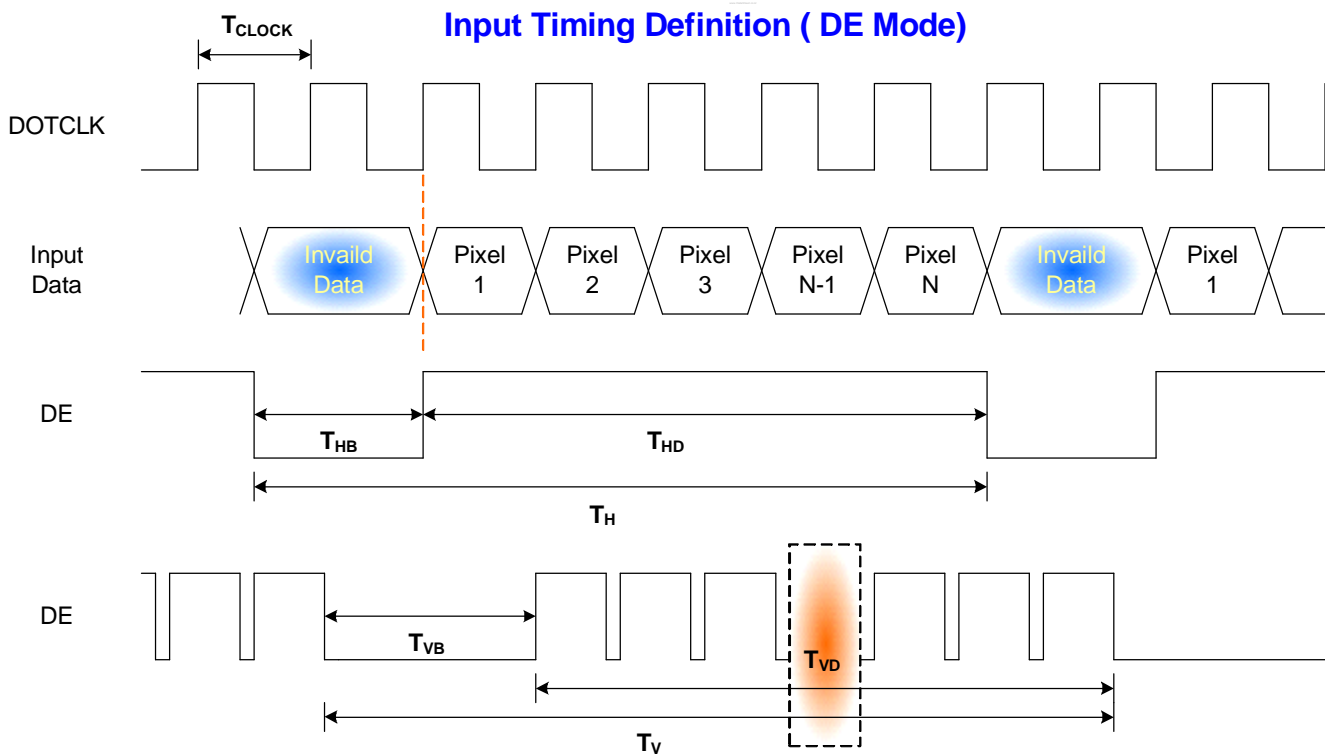

6.5 Power ON/OFF Sequence

VDD power and lamp on/off sequence is as follows. Interface signals are also shown in the chart. Signals from any system shall be Hi-Z state or low level when VDD is off.

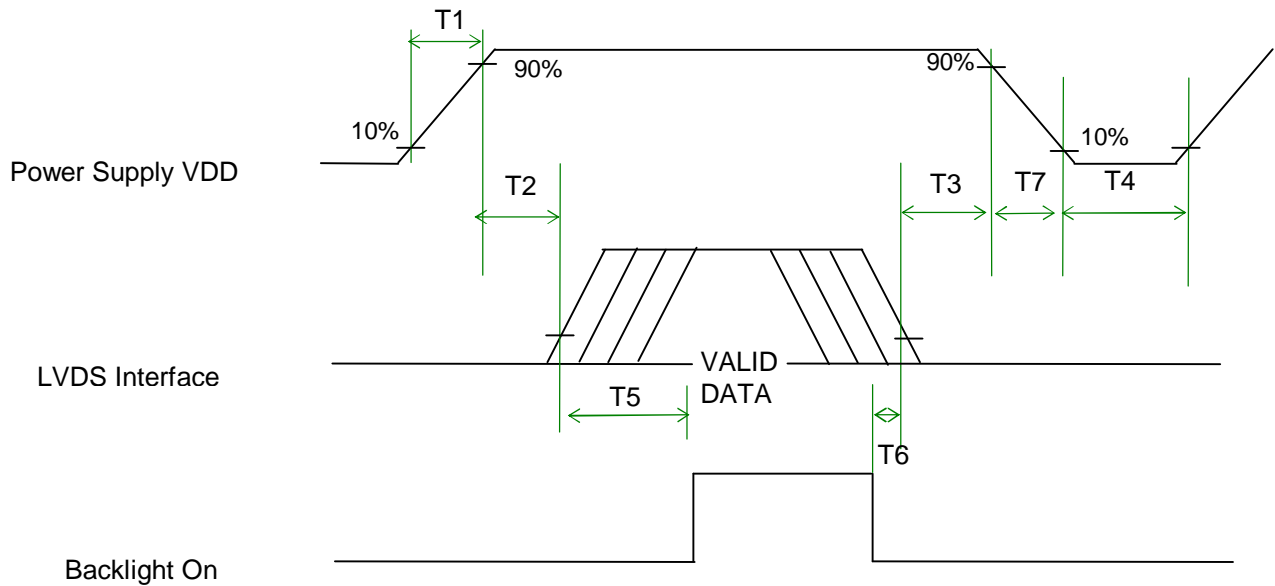

Power Sequence Timing

Parameter	Value			Units
	Min.	Typ.	Max.	
T1	0.5	-	10	(ms)
T2	0	-	50	(ms)
T3	0	-	50	(ms)
T4	400	-	-	(ms)
T5	200	-	-	(ms)
T6	200	-	-	(ms)
T7	0	-	10	(ms)



Product Specification

AU OPTRONICS CORPORATION

B141EW01 V5

7. Connector Description

Physical interface is described as for the connector on module.

These connectors are capable of accommodating the following signals and will be following components.

7.1 TFT LCD Module

Connector Name / Designation	For Signal Connector
Manufacturer	JAE
Type / Part Number	FI-XB30SL-HF10
Mating Housing/Part Number	F1-X30H
Mating Contact/Part Number	F1-XC3-1-15000

7.2 Backlight Unit

Physical interface is described as for the connector on module.

These connectors are capable of accommodating the following signals and will be following components.

Connector Name / Designation	For Lamp Connector
Manufacturer	JST
Type / Part Number	BHSR-02VS-1
Mating Type / Part Number	SM02B-BHSS-1-TB

7.3 Signal for Lamp connector

Pin #	Cable color	Signal Name
1	Red	Lamp High Voltage
2	White	Lamp Low Voltage



Product Specification

AU OPTRONICS CORPORATION

B141EW01 V5

8. Vibration and Shock Test

8.1 Vibration Test

Test Spec:

- I Test method: Non-Operation
- I Acceleration: 1.5G , sine wave
- I Frequency: 10 - 500Hz Random
- I Sweep: 0.5 octave/minute in each of three mutually perpendicular axes.

8.2 Shock Test Spec:

Test Spec:

- I Test method: Non-Operation
- I Acceleration: 220 G , Half sine wave
- I Active time: 2 ms
- I Pulse: Half sine wave



Product Specification

AU OPTRONICS CORPORATION

B141EW01 V5

9. Reliability

Items	Required Condition	Note
Temperature Humidity Bias	40°C/90%,300Hr	
High Temperature Operation	50°C/20%,300Hr	
Low Temperature Operation	0°C,300Hr	
On/Off Test	25°C, ON/10 sec. OFF/10sec., 30,000 cycles	
Hot Storage	65°C/20% RH ,300 hours	
Cold Storage	-25°C/50% RH ,300 hours	
Thermal Shock Test	-20°C/30 min ,60°C/30 min 100cycles	
Hot Start Test	50°C/1 Hr min. power on/off per 5 minutes, 5 times	
Cold Start Test	0°C/1 Hr min. power on/off per 5 minutes, 5 times	
Shock Test (Non-Operating)	220G, 2ms, Half-sine wave	
Vibration Test (Non-Operating)	Sinusoidal vibration, 1.5G zero-to-peak, 10 to 500 Hz, 0.5 octave/minute in each of three mutually perpendicular axes.	
ESD	Contact : ±8KV, operation, class B Air : ±15KV, operation, class B	Note 1

Note1: According to EN61000-4-2 , ESD class B: Some performance degradation allowed. No data lost . Self-recoverable. No hardware failures.

Note2: CCFL Life time: 10,000 hours minimum under normal module usage.

Note3: MTBF (Excluding the CCFL): 30,000 hours with a confidence level 90%

10. Mechanical Characteristics

10.1 LCM Outline Dimension

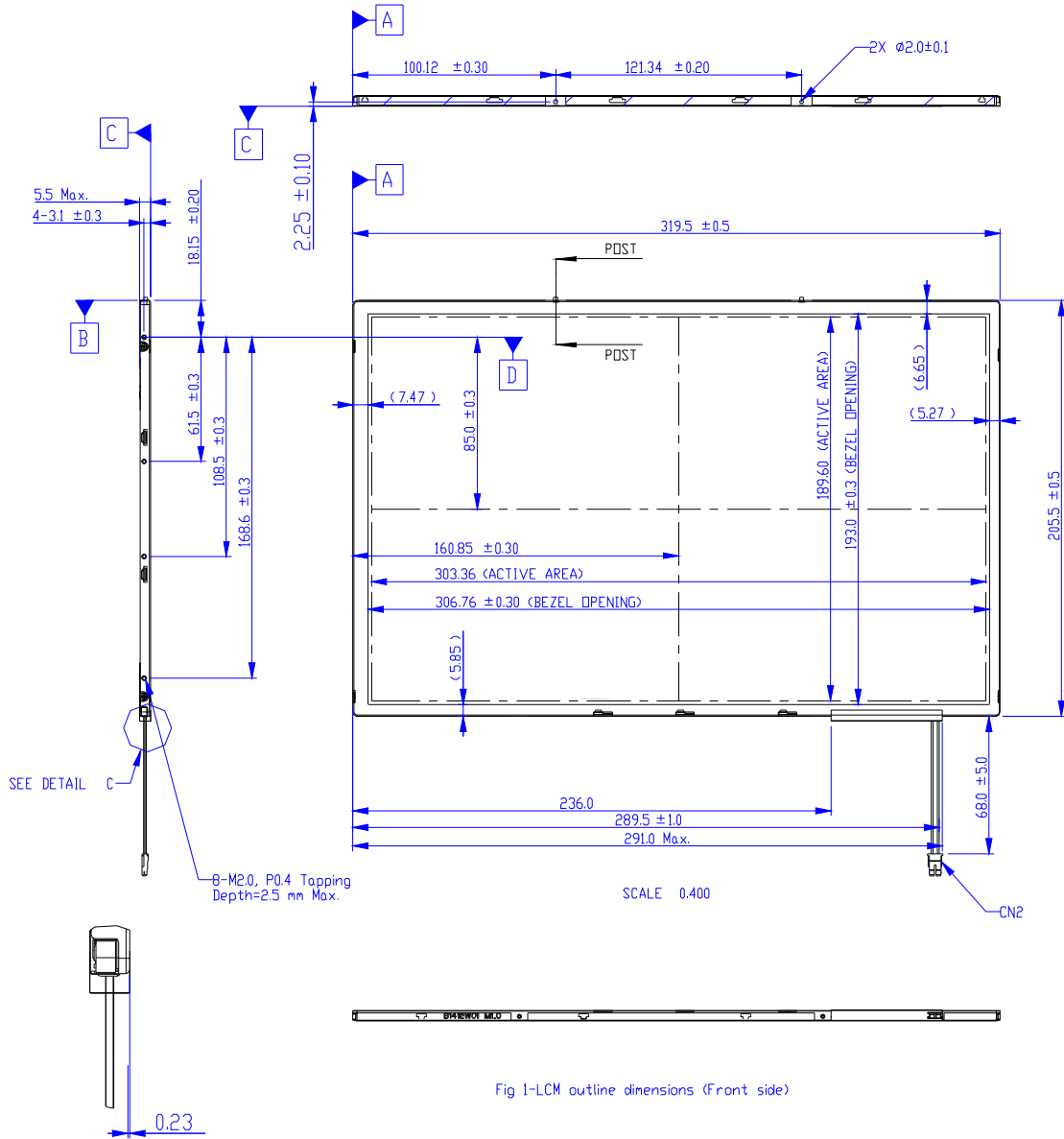
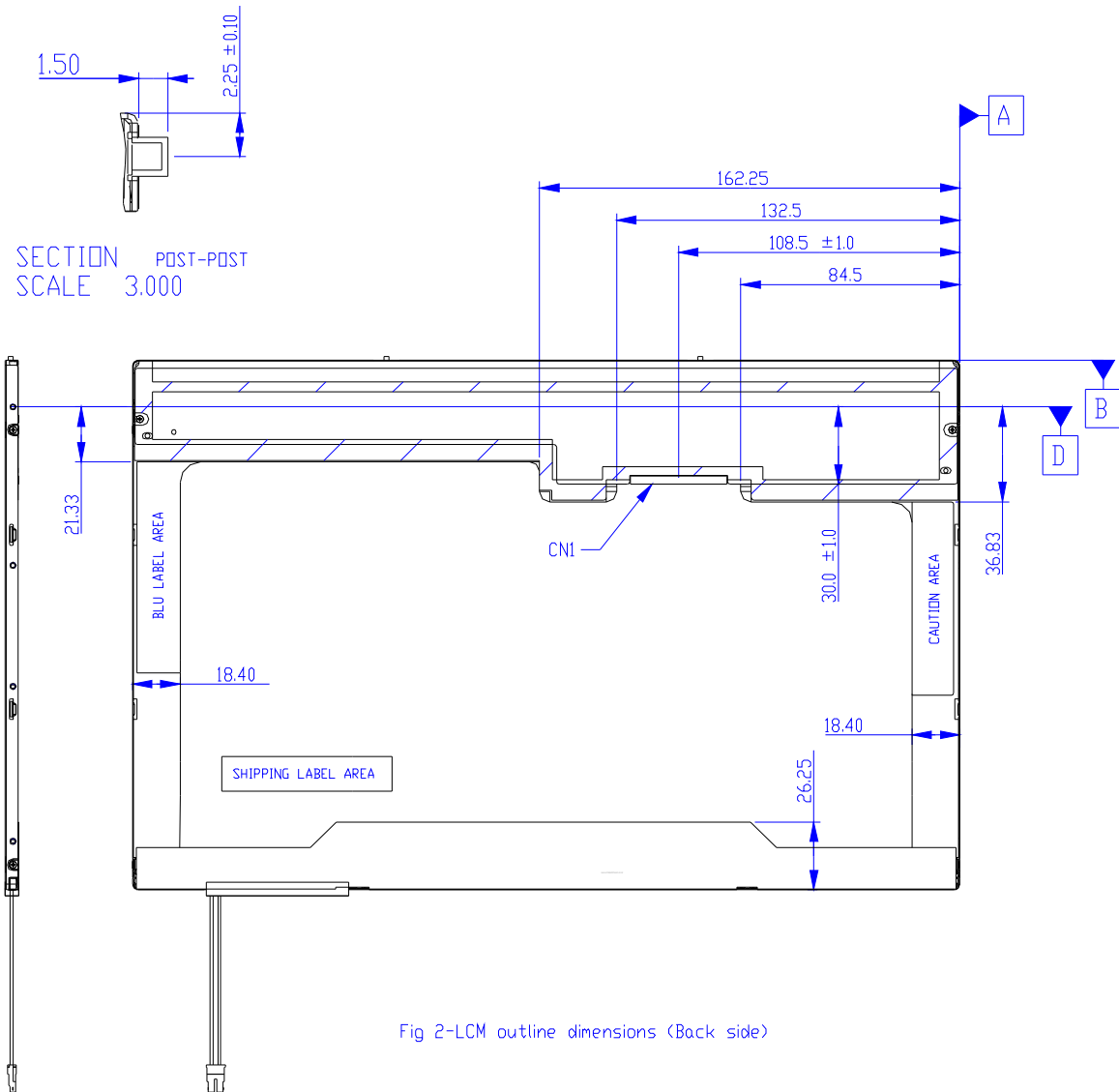

Fig 1-LCM outline dimensions (Front side)

DETAIL c
SCALE 1.500

NOTE:
1. Dimensions are ± 0.3 mm unless noted.
2. Connector type:
CN1: JAE F1-XB30SL-HF10
CN2: JST BHSR-02VS-1
3. Mating connector: SM02B-BHSS-1-TB



10.2 Screw Hole Depth and Center Position

Screw hole minimum depth, from side surface = 2.5 mm (See drawing)

Screw hole center location, from front surface = 3.1 ± 0.1 mm (See drawing)

Suggestions: Customers' Screw maximum length = 2.3 mm (See drawing)

Screw Torque: Maximum 2.5 kgf-cm

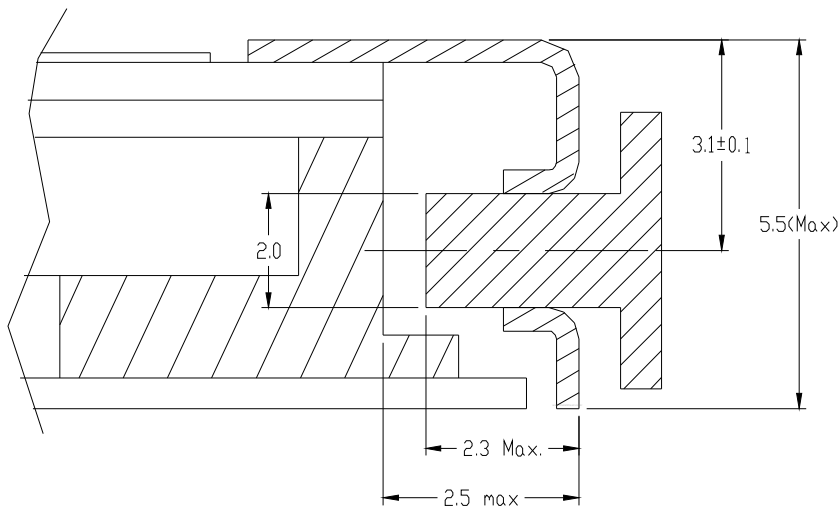

11. Shipping and Package

11.1 Shipping Label Format



11.2. Carton package

The outside dimension of carton is 454(L)mm* 388(W)mm* 352(H)mm, carton and cushion weight are 2920g.

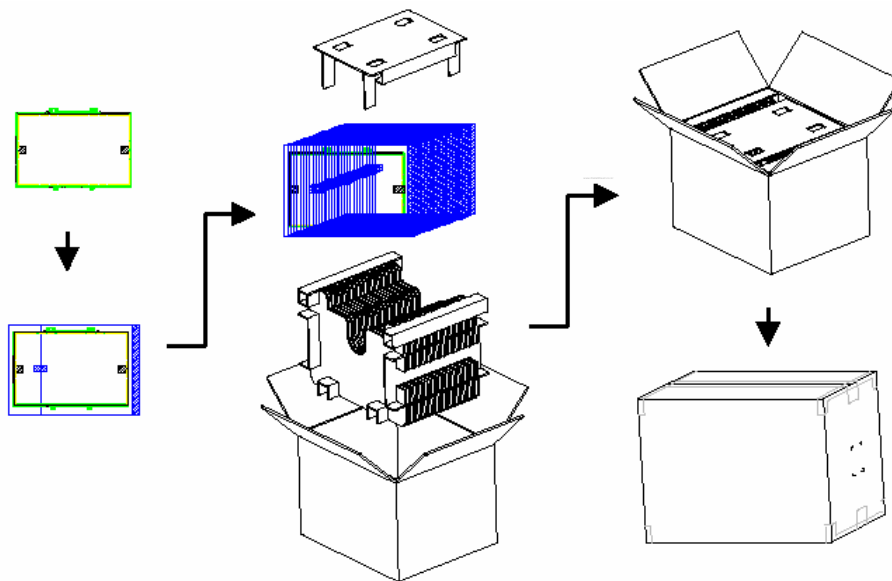

11.3 Shipping package of palletizing

By air : 6 *4 layers, one pallet put 24 boxes, total 480 pcs module.

By sea : 6 *5 layers, one pallet put 30 boxes, total 600 pcs module.

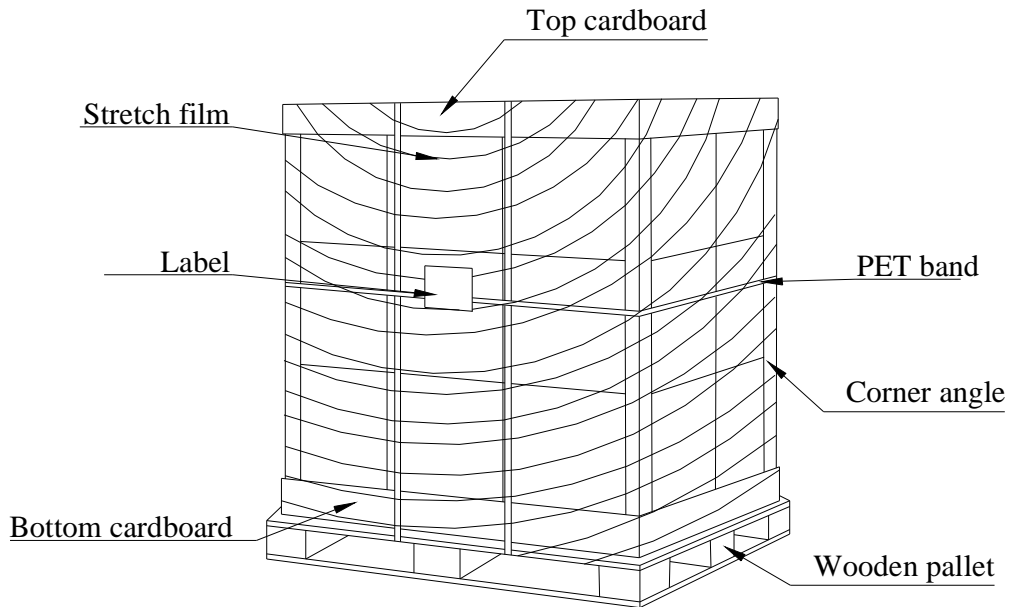



Product Specification

AU OPTRONICS CORPORATION

B141EW01 V5

12. Appendix: EDID Description

H/W: 0A

HEX	FUNCTION	Value HEX	Value BIN	Value DEC
00	Header	00	00000000	0
01	Header	FF	11111111	255
02	Header	FF	11111111	255
03	Header	FF	11111111	255
04	Header	FF	11111111	255
05	Header	FF	11111111	255
06	Header	FF	11111111	255
07	Header	00	00000000	0
08	EISA manufacture code = 3 Character ID	06	00000110	6
09	EISA manufacture code (Compressed ASCII)	AF	10101111	175
0A	Panel Supplier Reserved – Product Code	44	01000100	68
0B	Panel Supplier Reserved – Product Code	15	00010101	21
0C	LCD module Serial No - Preferred but Optional (“0” if not used)	00	00000000	0
0D	LCD module Serial No - Preferred but Optional (“0” if not used)	00	00000000	0
0E	LCD module Serial No - Preferred but Optional (“0” if not used)	00	00000000	0
0F	LCD module Serial No - Preferred but Optional (“0” if not used)	00	00000000	0
10	Week of manufacture	01	00000001	1
11	Year of manufacture	10	00010000	16
12	EDID structure version # = 1	01	00000001	1
13	EDID revision # = 3	03	00000011	3
14	Video I/P definition = Digital I/P (80h)	80	10000000	128
15	Max H image size = (Rounded to cm)	1E	00011110	30
16	Max V image size = (Rounded to cm)	13	00010011	19
17	Display gamma = (gamma ×100)-100 Example: (2.2×100) – 100 = 120	78	01111000	120



Product Specification

AU OPTRONICS CORPORATION

B141EW01 V5

18	Feature support (no DPMS, Active off, RGB, timing BLK 1)	0A	00001010	10
19	Red/Green Low bit (RxRy/GxGy)	87	10000111	135
1A	Blue/White Low bit (BxBY/WxWy)	F5	11110101	245
1B	Red X	94	10010100	148
1C	Red Y	57	01010111	87
1D	Green X	4F	01001111	79
1E	Green Y	8C	10001100	140
1F	Blue X	27	00100111	39
20	Blue Y	27	00100111	39
21	White X	50	01010000	80
22	White Y	54	01010100	84
23	Established timings 1 (00h if not used)	00	00000000	0
24	Established timings 2 (00h if not used)	00	00000000	0
25	Manufacturer's timings (00h if not used)	00	00000000	0
26	Standard timing ID1 (01h if not used)	01	00000001	1
27	Standard timing ID1 (01h if not used)	01	00000001	1
28	Standard timing ID2 (01h if not used)	01	00000001	1
29	Standard timing ID2 (01h if not used)	01	00000001	1
2A	Standard timing ID3 (01h if not used)	01	00000001	1
2B	Standard timing ID3 (01h if not used)	01	00000001	1
2C	Standard timing ID4 (01h if not used)	01	00000001	1
2D	Standard timing ID4 (01h if not used)	01	00000001	1
2E	Standard timing ID5 (01h if not used)	01	00000001	1
2F	Standard timing ID5 (01h if not used)	01	00000001	1
30	Standard timing ID6 (01h if not used)	01	00000001	1
31	Standard timing ID6 (01h if not used)	01	00000001	1
32	Standard timing ID7 (01h if not used)	01	00000001	1
33	Standard timing ID7 (01h if not used)	01	00000001	1
34	Standard timing ID8 (01h if not used)	01	00000001	1
35	Standard timing ID8 (01h if not used)	01	00000001	1
36	Pixel Clock/10,000 (LSB)	EA	11101010	234
37	Pixel Clock/10,000 (MSB)	1A	00011010	26
38	Horizontal Active (lower 8 bits)	00	00000000	0
39	Horizontal Blanking (Thbp) (lower 8 bits)	80	10000000	128
3A	Horizontal Active/Horizontal blanking (Thbp) (upper4:4 bits)	50	01010000	80
3B	Vertical Active	20	00100000	32



Product Specification

AU OPTRONICS CORPORATION

B141EW01 V5

3C	Vertical Blanking (Tvbp) (DE Blanking typ. for DE only panels)	10	00010000	16
3D	Vertical Active: Vertical Blanking (Tvbp) (upper4:4 bits)	30	00110000	48
3E	Horizontal Sync, Offset (Thfp)	30	00110000	48
3F	Horizontal Sync, Pulse Width	20	00100000	32
40	Vertical Sync, Offset (Tvfp) Sync Width	36	00110110	54
41	Horizontal Vertical Sync Offset/Width upper 2 bits	00	00000000	0
42	Horizontal Image Size	30	00110000	48
43	Vertical image Size	BE	10111110	190
44	Horizontal Image Size / Vertical image size	10	00010000	16
45	Horizontal Border = 0 (Zero for Notebook LCD)	00	00000000	0
46	Vertical Border = 0 (Zero for Notebook LCD)	00	00000000	0
47	Non-interlaced, Normal, no stereo, Separate sync, H/V pol Negatives, DE only note: LSB is set to "1" if panel is DE-timing only. H/V can be ignored.	18	00011000	24
48	Pixel Clock/10,000 (LSB)	00	00000000	0
49	Pixel Clock/10,000 (MSB)	00	00000000	0
4A	Horizontal Active = xxxx pixels (lower 8 bits)	00	00000000	0
4B	Horizontal Blanking (Thbp) = xxxx pixels (lower 8 bits)	0F	00001111	15
4C	Horizontal Active/Horizontal blanking (Thbp) (upper4:4 bits)	00	00000000	0
4D	Vertical Active = xxxx lines	00	00000000	0
4E	Vertical Blanking (Tvbp) = xxxx lines (DE Blanking typ. for DE only panels)	00	00000000	0
4F	Vertical Active : Vertical Blanking (Tvbp) (upper4:4 bits)	00	00000000	0
50	Horizontal Sync, Offset (Thfp) = xxxx pixels	00	00000000	0
51	Horizontal Sync, Pulse Width = xxxx pixels	00	00000000	0
52	Vertical Sync, Offset (Tvfp) = xx lines Sync Width = xx lines	00	00000000	0
53	Horizontal Vertical Sync Offset/Width upper 2 bits	00	00000000	0
54	Horizontal Image Size =xxx mm	00	00000000	0
55	Vertical image Size = xxx mm	00	00000000	0
56	Horizontal Image Size / Vertical image size	00	00000000	0
57	Horizontal Border = 0 (Zero for Notebook LCD)	00	00000000	0
58	Vertical Border = 0 (Zero for Notebook LCD)	00	00000000	0
59	Module "A" Revision = Example: 00, 01, 02, 03, etc.	20	00100000	32
5A	Flag	00	00000000	0



Product Specification

AU OPTRONICS CORPORATION

B141EW01 V5

5B	Flag	00	00000000	0
5C	Flag	00	00000000	0
5D	Dummy Descriptor	FE	11111110	254
5E	Flag	00	00000000	0
5F	Dell P/N 1 st Character	41	01000001	65
60	Dell P/N 2 nd Character	55	01010101	85
61	Dell P/N 3 rd Character	4F	01001111	79
62	Dell P/N 4 th Character	0A	00001010	10
63	Dell P/N 5 th Character	20	00100000	32
64	LCD Supplier EEDID Revision #	20	00100000	32
65	Manufacturer P/N	20	00100000	32
66	Manufacturer P/N	20	00100000	32
67	Manufacturer P/N	20	00100000	32
68	Manufacturer P/N	20	00100000	32
69	Manufacturer P/N	20	00100000	32
6A	Manufacturer P/N	20	00100000	32
6B	Manufacturer P/N (If <13 char, then terminate with ASCII code 0Ah, set remaining char = 20h)	20	00100000	32
6C	Flag	00	00000000	0
6D	Flag	00	00000000	0
6E	Flag	00	00000000	0
6F	Data Type Tag:	FE	11111110	254
70	Flag	00	00000000	0
71	SMBUS Value	42	01000010	66
72	SMBUS Value	31	00110001	49
73	SMBUS Value	34	00110100	52
74	SMBUS Value	31	00110001	49
75	SMBUS Value	45	01000101	69
76	SMBUS Value	57	01010111	87
77	SMBUS Value	30	00110000	48
78	SMBUS Value = max nits (Typically = 00h)	31	00110001	49
79	Number of LVDS receiver chips = '01' or '02'	20	00100000	32
7A	BIST Enable: Yes = '01' No = '00'	56	01010110	86
7B	(If <13 char, then terminate with ASCII code 0Ah, set remaining char = 20h)	35	00110101	53
7C	(If <13 char, then terminate with ASCII code 0Ah, set	20	00100000	32



Product Specification

AU OPTRONICS CORPORATION

B141EW01 V5

	remaining char = 20h)			
7D	(If <13 char, then terminate with ASCII code 0Ah, set remaining char = 20h)	0A	00001010	10
7E	Extension flag (# of optional 128 EDID extension blocks to follow, Typ = 0)	00	00000000	0
7F	Checksum (The 1-byte sum of all 128 bytes in this EDID block shall = 0)	B8	10111000	184