



Product Specification

AU OPTRONICS CORPORATION

Contents

1. Handling Precautions	4
2. General Description	5
2.1 General Specification	5
2.2 Optical Characteristics	6
3. Functional Block Diagram	11
4. Absolute Maximum Ratings	12
4.1 Absolute Ratings of TFT LCD Module	12
4.2 Absolute Ratings of Environment	12
5. Electrical characteristics	13
5.1 TFT LCD Module	13
5.2 Backlight Unit	15
6. Signal Characteristic	16
6.1 Pixel Format Image	16
6.2 The input data format	17
6.3 Integration Interface and Pin Assignment	18
6.4 Interface Timing	21
7. Vibration and Shock Test	23
7.1 Vibration Test	23
7.2 Shock Test Spec:	23
7.3 Reliability Test	24
8. Mechanical Characteristics	25
8.1 LCM Outline Dimension	25
8.2 Screw Hole Depth and Center Position	27
9. Shipping and Package	28
9.1 Shipping Label Format	28
9.2 Carton package	29
9.3 Shipping package of palletizing sequence	29
10. Appendix: EDID description	30



Product Specification

AU OPTRONICS CORPORATION

Record of Revision

Version and Date	Page	Old description	New Description	Remark
0.1 2009/02/14	All	First Edition for Customer		
0.2 2009/04/07		Update the 2D drawings Update the EDID		
0.3 2009/05/23	P.6 P.11 P.13 P.15 P.18 P.21 P.22		Update Color / Chromaticity Coordinates Update Function Block Update Power Specification Update BLU LED/Power Characteristics Update Connector type/Pin Assignment Update Interface Timing Update Power ON/OFF Sequence	
0.4 2009/09/22	P.11 P.15 P.18 P.22 P.20 P.26 P.30-33	w/o EDID block LED lifetime 10,000 hr N/A IPEX or compatible AUO Default Drawing w/o Gusket Drawing w/o Gusket EDID (69.95 Mhz)	Add EDID block Update LED lifetime to 12,000 hr Update the mini. value from 5% to 1% Update LVDS connector supplier info Update Power on/off sequence (Lenovo) Drawing w/ Gusket (WWAN solution) Drawing w/ Gusket (WWAN solution) EDID (68.8 Mhz) (WWAN solution)	
1.0 2009/10/09	P.21 P.22 P.26	Regular Note for interface timing Power on/off sequence (Lenovo) Regular outline drawing	Update the noticed of 40Hz effect Update on/off sequence (same as WXGA+) Update drawing (barcode location and cover)	



Product Specification

AU OPTRONICS CORPORATION

1. Handling Precautions

- 1) Since front polarizer is easily damaged, pay attention not to scratch it.
- 2) Be sure to turn off power supply when inserting or disconnecting from input connector.
- 3) Wipe off water drop immediately. Long contact with water may cause discoloration or spots.
- 4) When the panel surface is soiled, wipe it with absorbent cotton or other soft cloth.
- 5) Since the panel is made of glass, it may break or crack if dropped or bumped on hard surface.
- 6) Since CMOS LSI is used in this module, take care of static electricity and insure human earth when handling.
- 7) Do not open nor modify the Module Assembly.
- 8) Do not press the reflector sheet at the back of the module to any directions.
- 9) At the insertion or removal of the Signal Interface Connector, be sure not to rotate nor tilt the Interface Connector of the TFT Module.
- 11) After installation of the TFT Module into an enclosure (Notebook PC Bezel, for example), do not twist nor bend the TFT Module even momentarily. At designing the enclosure, it should be taken into consideration that no bending/twisting forces are applied to the TFT Module from outside. Otherwise the TFT Module may be damaged.
- 12) Small amount of materials having no flammability grade is used in the LCD module. The LCD module should be supplied by power complied with requirements of Limited Power Source (IEC60950 or UL1950), or be applied exemption.
- 13) Disconnecting power supply before handling LCD modules, it can prevent electric shock, DO NOT TOUCH the electrode parts, cables, connectors and LED circuit part of TFT module that a LED light bar build in as a light source of back light unit. High voltage is supplied to these parts when power turn on.



Product Specification

AU OPTRONICS CORPORATION

2. General Description

B141EW05 V4 is a Color Active Matrix Liquid Crystal Display composed of a TFT LCD panel, a driver circuit, and LED backlight system. The screen format is intended to support the WXGA (1280(H) x 800(V)) screen and 262k colors (RGB 6-bits data driver) with LED backlight driving circuit. All input signals are LVDS interface compatible.

B141EW05 V4 is designed for a display unit of notebook style personal computer and industrial machine.

2.1 General Specification

The following items are characteristics summary on the table at 25 °C condition:

Items	Unit	Specifications			
Screen Diagonal	[mm]	357.7 (14.1W")			
Active Area	[mm]	303.36 X 189.6			
Pixels H x V		1280x3(RGB) x 800			
Pixel Pitch	[mm]	0.237			
Pixel Format		R.G.B. Vertical Stripe			
Display Mode		Normally White			
White Luminance (I _{LED} =20mA) Note: I _{LED} is LED current	[cd/m ²]	220 typ. (5 points average) 187 min. (5 points average) (Note1)			
Luminance Uniformity		1.25 max. (5 points)			
Contrast Ratio		400 typ			
Response Time	[ms]	8 typ / 16 Max			
Nominal Input Voltage VDD	[Volt]	+3.3 typ.			
Power Consumption	[Watt]	5.5 max. (Include Logic and Blu power) (Note1)			
Weight	[Grams]	390 max.			
Physical Size without inverter, bracket.	[mm]		Min.	Typ.	Max.
		Length	319	319.5	320
		Width	205	205.5	206
		Thickness	4.8	-	5.5
Electrical Interface		1 channel LVDS			
Surface Treatment		Anti-Glare,			



Product Specification

AU OPTRONICS CORPORATION

Support Color		262K colors (RGB 6-bit)
Temperature Range Operating Storage (Non-Operating)	[°C] [°C]	0 to +50 -20 to +65
RoHS Compliance		RoHS Compliance

Note 1. Total power consumption including LED power efficiency <4.9W max.

2.2 Optical Characteristics

The optical characteristics are measured under stable conditions at 25°C (Room Temperature) :

Item	Symbol	Conditions	Min.	Typ.	Max.	Unit	Note
White Luminance $I_{LED}=20mA$		5 points average	187	220	-	cd/m ²	1, 4, 5.
Viewing Angle	θ_R	Horizontal (Right)	40	45	-	degree	4, 9
	θ_L	CR = 10 (Left)	40	45	-		
	ϕ_H	Vertical (Upper)	10	20	-		
	ϕ_L	CR = 10 (Lower)	30	40	-		
Luminance Uniformity	δ_{5P}	5 Points	-	-	1.25		1, 3, 4
Luminance Uniformity	δ_{13P}	13 Points	-	-	1.50		2, 3, 4
Contrast Ratio	CR		300	400	-		4, 6
Cross talk	%				4		4, 7
Response Time	T_r	Rising	-	6	10	msec	4, 8
	T_f	Falling	-	2	5-		
	T_{RT}	Rising + Falling	-	8	12		
Color / Chromaticity Coordinates NTSC	Red x	CIE 1931	0.556	0.586	0.616		4
	Red y		0.316	0.346	0.376		
	Green x		0.311	0.341	0.371		
	Green y		0.546	0.576	0.606		
	Blue x		0.127	0.157	0.187		
	Blue y		0.090	0.120	0.150		
	White x		0.283	0.313	0.343		
	White y		0.299	0.329	0.359		
%	-	45	-				



Product Specification

AU OPTRONICS CORPORATION

Note 1: 5 points position (Ref: Active area)

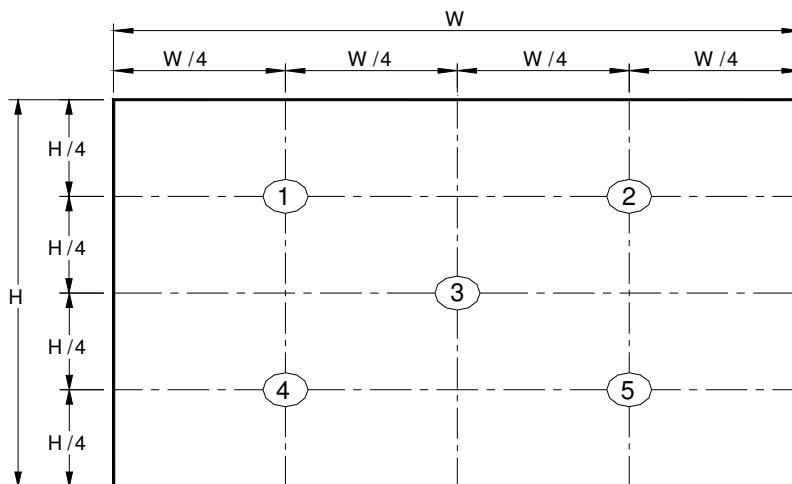

Note 2: 13 points position (Ref: Active area)

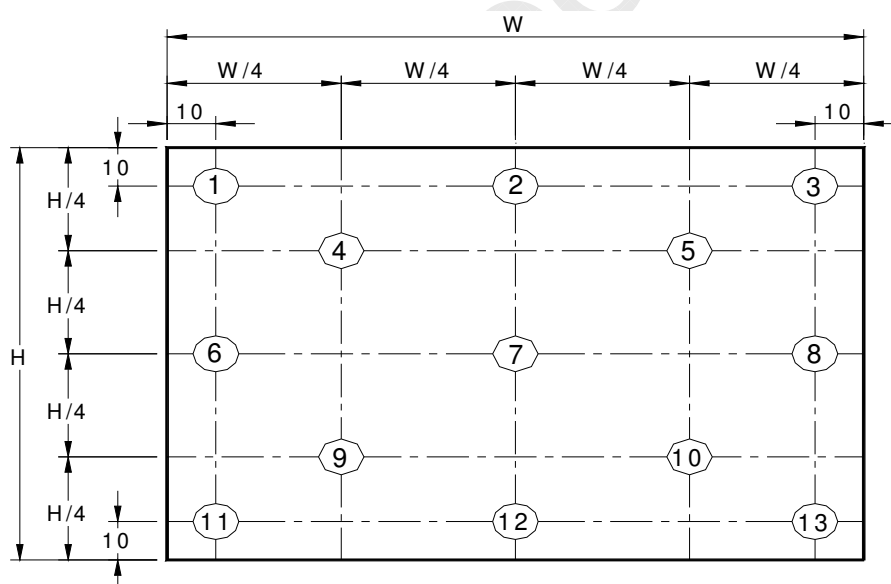

Note 3: The luminance uniformity of 5 or 13 points is defined by dividing the maximum luminance values by the minimum test point luminance

$$\delta_{w5} = \frac{\text{Maximum Brightness of five points}}{\text{Minimum Brightness of five points}}$$

$$\delta_{w13} = \frac{\text{Maximum Brightness of thirteen points}}{\text{Minimum Brightness of thirteen points}}$$

Note 4: Measurement method



Product Specification

AU OPTRONICS CORPORATION

The LCD module should be stabilized at given temperature for 30 minutes to avoid abrupt temperature change during measuring. In order to stabilize the luminance, the measurement should be executed after lighting Backlight for 30 minutes in a stable, windless and dark room, and it should be measured in the center of screen.

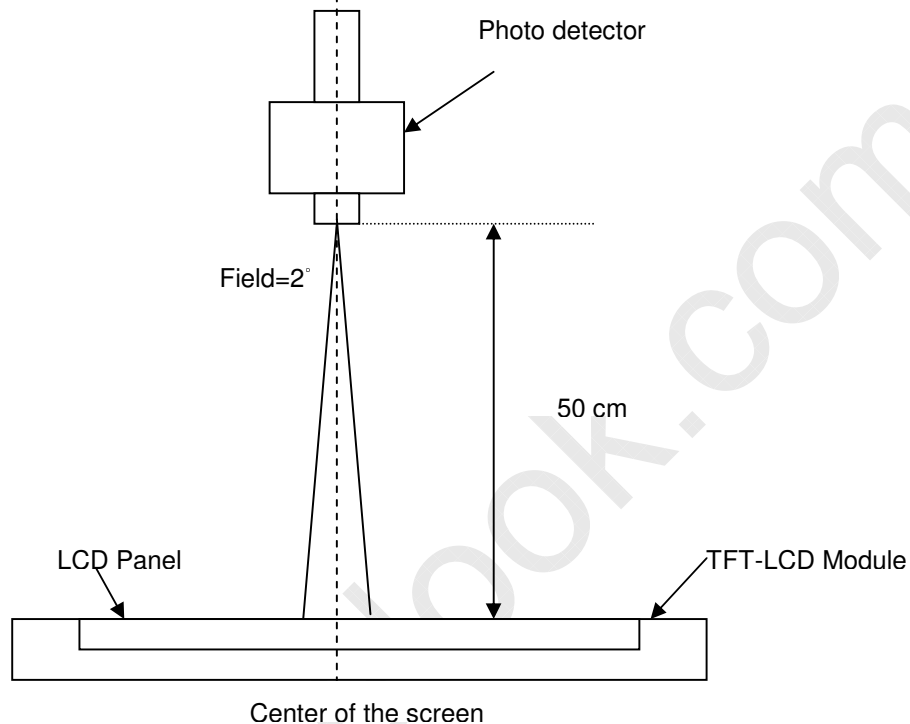

Note 5 : Definition of Average Luminance of White (Y_L):

Measure the luminance of gray level 63 at 5 points · $Y_L = [L(1) + L(2) + L(3) + L(4) + L(5)] / 5$

$L(x)$ is corresponding to the luminance of the point X at Figure in Note (1).

Note 6 : Definition of contrast ratio:

Contrast ratio is calculated with the following formula.

$$\text{Contrast ratio (CR)} = \frac{\text{Brightness on the "White" state}}{\text{Brightness on the "Black" state}}$$

Note 7 : Definition of Cross Talk (CT)

$$CT = |Y_B - Y_A| / Y_A \times 100 (\%)$$

Where

Y_A = Luminance of measured location without gray level 0 pattern (cd/m^2)



Product Specification

AU OPTRONICS CORPORATION

Y_B = Luminance of measured location with gray level 0 pattern (cd/m²)

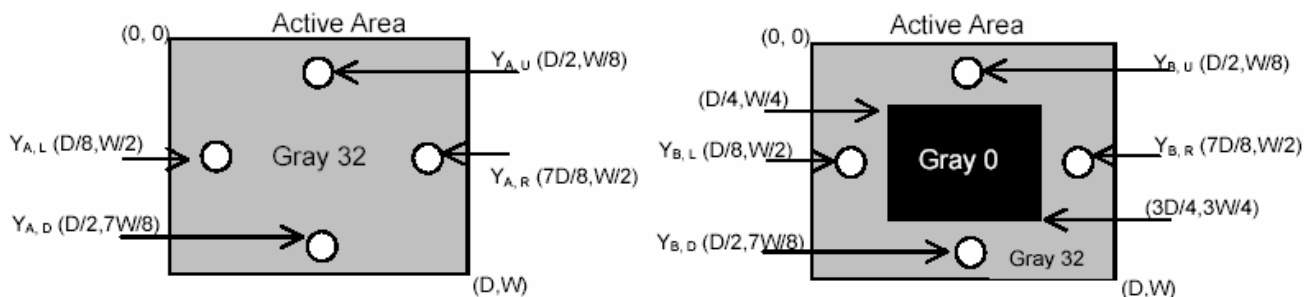

Note 8: Definition of response time:

The output signals of BM-7 or equivalent are measured when the input signals are changed from "Black" to "White" (falling time) and from "White" to "Black" (rising time), respectively. The response time interval between the 10% and 90% of amplitudes. Refer to figure as below.

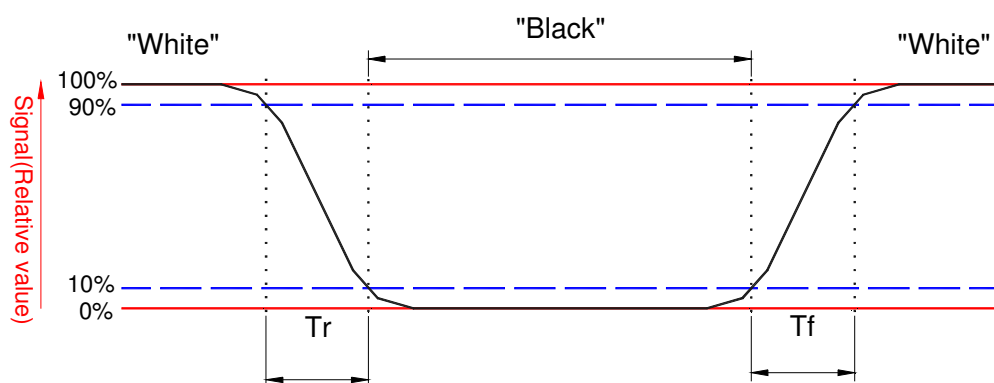



Product Specification

AU OPTRONICS CORPORATION

Note 9. Definition of viewing angle

Viewing angle is the measurement of contrast ratio ≥ 10 , at the screen center, over a 180° horizontal and 180° vertical range (off-normal viewing angles). The 180° viewing angle range is broken down as follows; 90° (θ) horizontal left and right and 90° (Φ) vertical, high (up) and low (down). The measurement direction is typically perpendicular to the display surface with the screen rotated about its center to develop the desired measurement viewing angle.

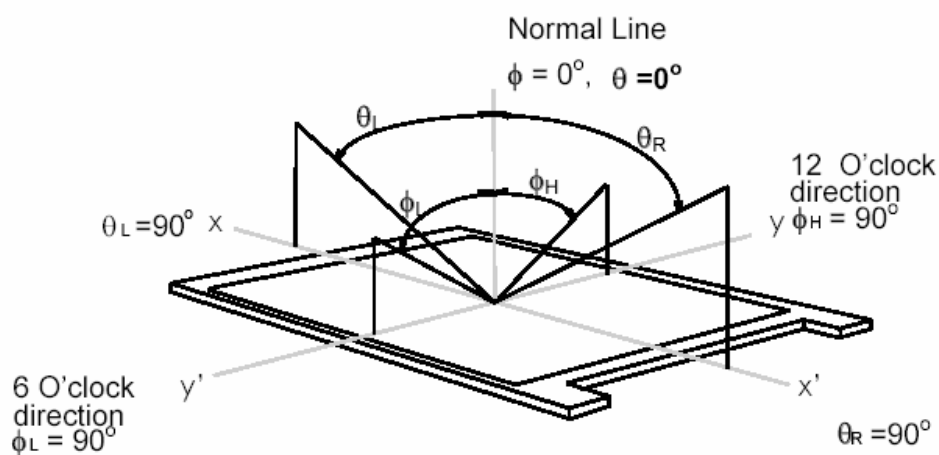



Product Specification

AU OPTRONICS CORPORATION

3. Functional Block Diagram

The following diagram shows the functional block of the 14.1 inches wide Color TFT/LCD 40 Pin (One ch/connector Module):

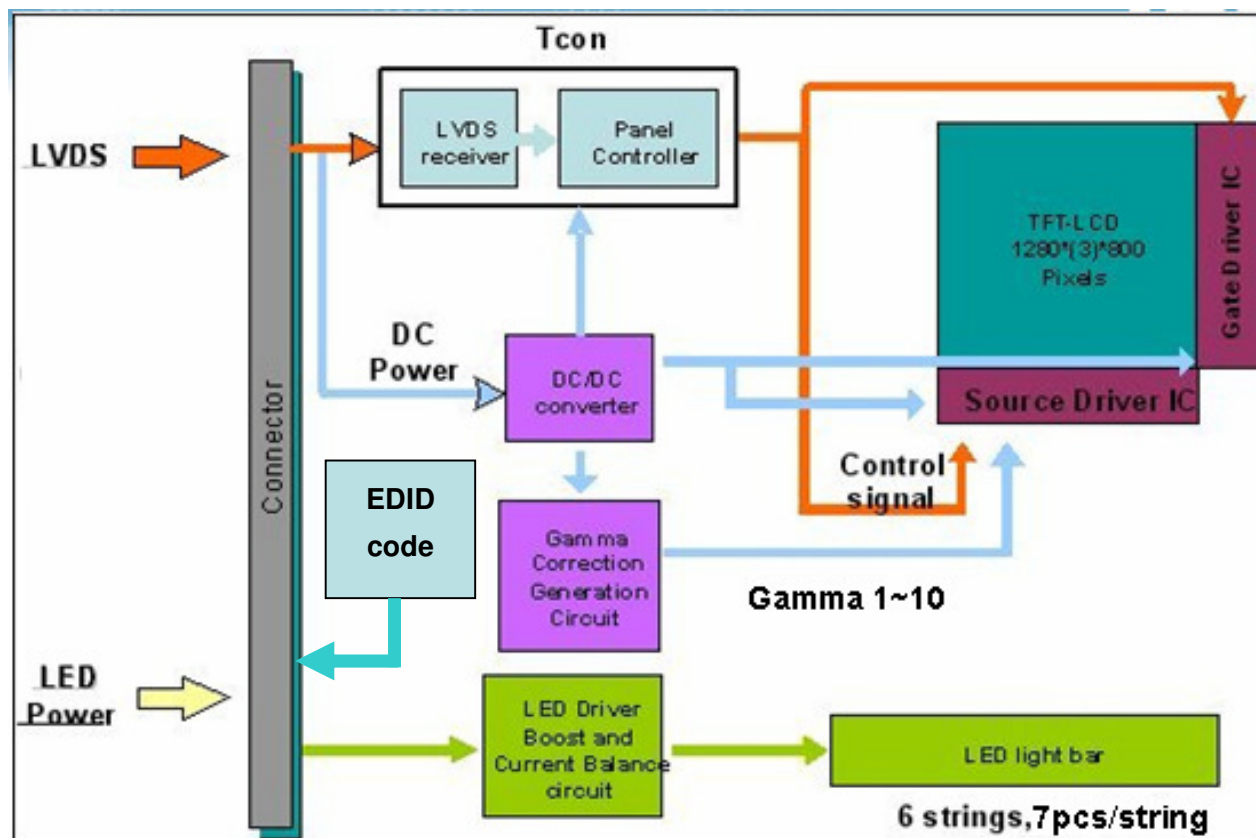



Product Specification

AU OPTRONICS CORPORATION

4. Absolute Maximum Ratings

An absolute maximum rating of the module is as following:

4.1 Absolute Ratings of TFT LCD Module

Item	Symbol	Min	Max	Unit	Conditions
Logic/LCD Drive Voltage	Vin	-0.3	+4.0	[Volt]	Note 1,2

4.2 Absolute Ratings of Environment

Item	Symbol	Min	Max	Unit	Conditions
Operating Temperature	TOP	0	+50	[°C]	Note 4
Operation Humidity	HOP	8	95	[%RH]	Note 4
Storage Temperature	TST	-20	+65	[°C]	Note 4
Storage Humidity	HST	5	95	[%RH]	Note 4

Note 1: At Ta (25°C)

Note 2: Permanent damage to the device may occur if exceed maximum values

Note 3: LED specification refer to section 5.2

Note 4: For quality performance, please refer to AUO IIS (Incoming Inspection Standard).

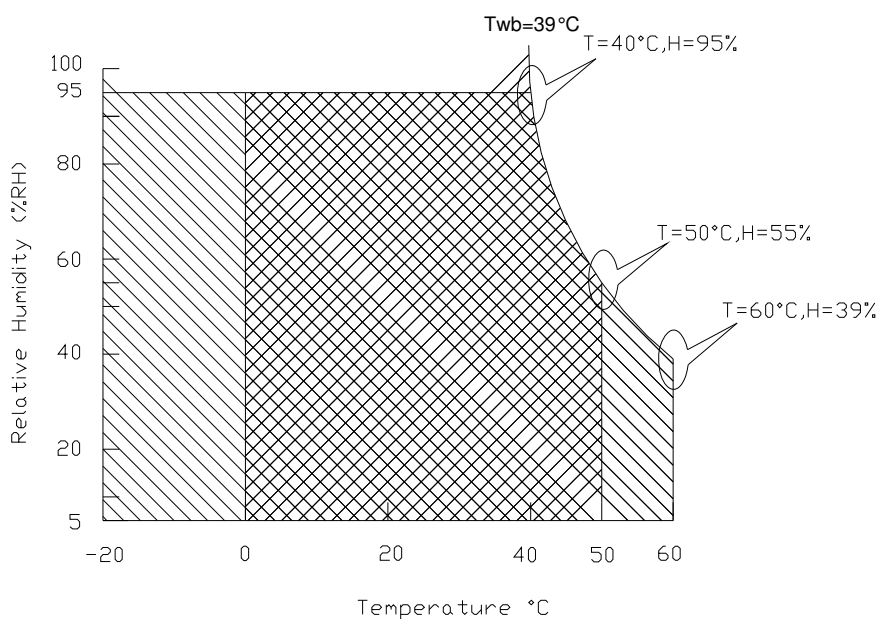

Operating Range

Storage Range +



Product Specification

AU OPTRONICS CORPORATION

5. Electrical characteristics

5.1 TFT LCD Module

5.1.1 Power Specification

Input power specifications are as follows;

The power specification are measured under 25°C and frame frequency under 60Hz

Symble	Parameter	Min	Typ	Max	Units	Note
VDD	Logic/LCD Drive Voltage	3.0	3.3	3.6	[Volt]	
PDD	VDD Power	-	0.9	1.5	[Watt]	Note 1/2
IDD	IDD Current	-	270	500	[mA]	Note 1/2
IRush	Inrush Current	-	-	1500	[mA]	Note 3
VDDrp	Allowable Logic/LCD Drive Ripple Voltage	-	-	100	[mV] p-p	

Note 1 : Maximum Measurement Condition : Black Pattern

Note 2 : Typical Measurement Condition: Mosaic Pattern

Note 3 : Measure Condition

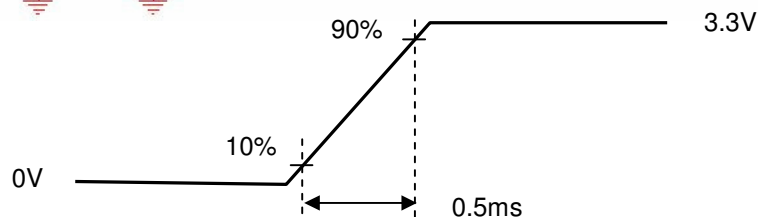
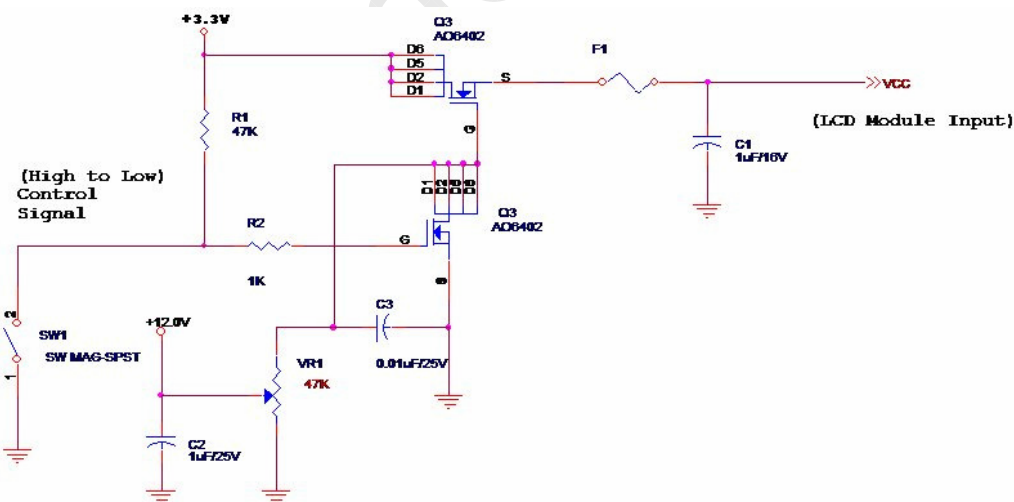

Vin rising time



Product Specification

AU OPTRONICS CORPORATION

5.1.2 Signal Electrical Characteristics

Input signals shall be low or High-impedance state when VDD is off.

It is recommended to refer the specifications of THC63LVDF84A (Thine Electronics Inc.) in detail.

Signal electrical characteristics are as follows;

Parameter	Condition	Min	Max	Unit
V_{th}	Differential Input High Threshold ($V_{cm}=+1.2V$)		100	[mV]
V_{tl}	Differential Input Low Threshold ($V_{cm}=+1.2V$)	-100	-	[mV]
V_{ID}	Differential Input Voltage	100	600	[mV]
V_{cm}	Differential Input Common Mode Voltage	1.125	1.375	[V]

Note: LVDS Signal Waveform

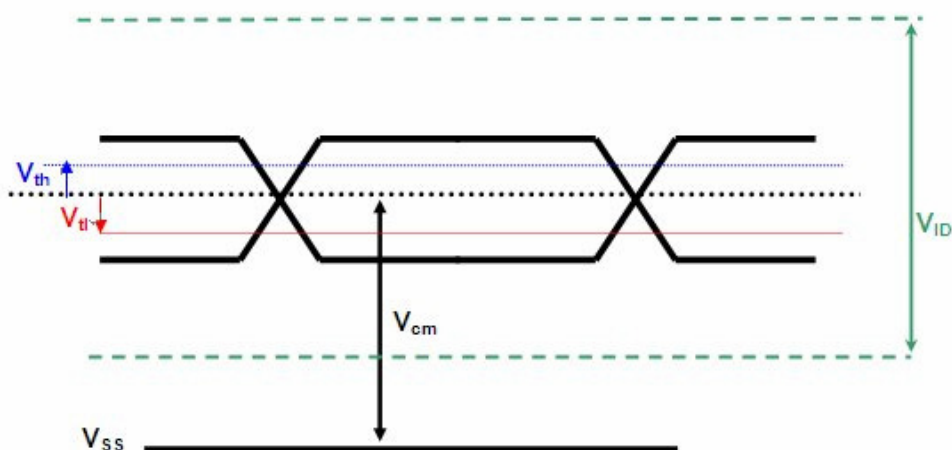



Product Specification

AU OPTRONICS CORPORATION

5.2 Backlight Unit

5.2.1 LED characteristics

Parameter	Symbol	Min	Typ	Max	Units	Condition
Backlight Power Consumption	PLED	-	-	3.5	[Watt]	(Ta=25°C), Note 1 Vin =12V
LED Life-Time	N/A	12,000	-	-	Hour	(Ta=25°C), Note 2 If=20 mA

Note 1: Calculator value for reference $P_{LED} = V_F$ (Normal Distribution) * I_F (Normal Distribution) / Efficiency

Note 2: The LED life-time define as the estimated time to 50% degradation of initial luminous.

5.2.2 Backlight input signal characteristics

Parameter	Symbol	Min	Typ	Max	Units	Remark
LED Power Supply	VLED	6.0	12.0	21.0	[Volt]	Define as Connector Interface (Ta=25°C)
LED Enable Input High Level	VLED_EN	2.1	-	-	[Volt]	
LED Enable Input Low Level		-	-	0.8	[Volt]	
PWM Logic Input High Level	VPWM_EN	2.1	-	-	[Volt]	
PWM Logic Input Low Level		-	-	0.8	[Volt]	
PWM Input Frequency	FPWM	100	-	20K	Hz	
PWM Duty Ratio	Duty	5	--	100	%	
PWM Duty Ratio	Duty	1	--	100	%	Output PWM frequency < 5KHz



Product Specification

AU OPTRONICS CORPORATION

6. Signal Characteristic

6.1 Pixel Format Image

Following figure shows the relationship of the input signals and LCD pixel format.

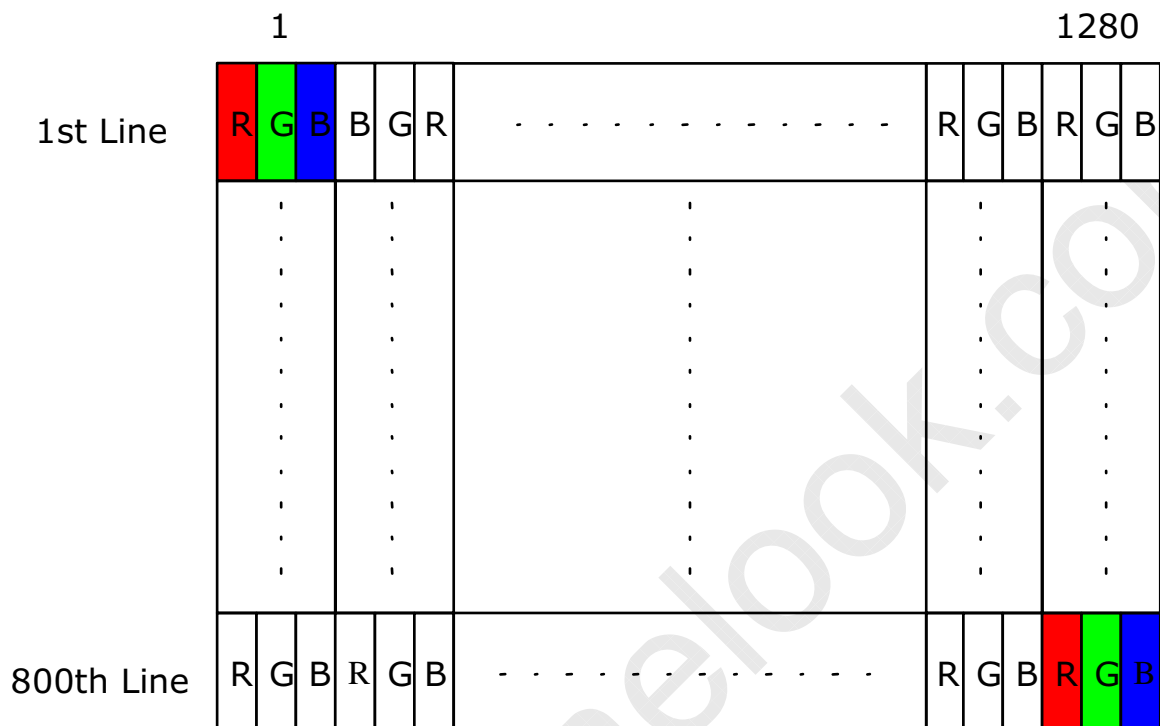



Product Specification

AU OPTRONICS CORPORATION

6.2 The input data format

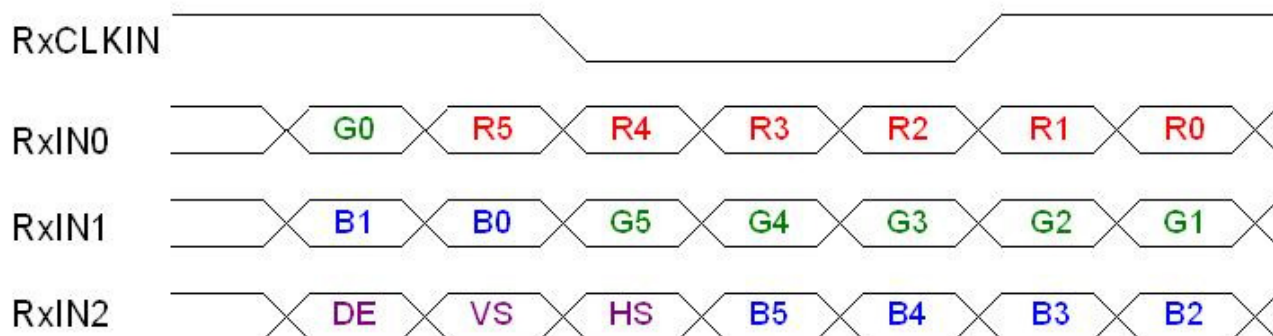

Signal Name	Description	
R5 R4 R3 R2 R1 R0	Red Data 5 (MSB) Red Data 4 Red Data 3 Red Data 2 Red Data 1 Red Data 0 (LSB)	Red-pixel Data Each red pixel's brightness data consists of these 6 bits pixel data.
G5 G4 G3 G2 G1 G0	Green Data 5 (MSB) Green Data 4 Green Data 3 Green Data 2 Green Data 1 Green Data 0 (LSB)	Green-pixel Data Each green pixel's brightness data consists of these 6 bits pixel data.
B5 B4 B3 B2 B1 B0	Blue Data 5 (MSB) Blue Data 4 Blue Data 3 Blue Data 2 Blue Data 1 Blue Data 0 (LSB)	Blue-pixel Data Each blue pixel's brightness data consists of these 6 bits pixel data.
RxCLKIN	Data Clock	The signal is used to strobe the pixel data and DE signals. All pixel data shall be valid at the falling edge when the DE signal is high.
DE	Display Timing	This signal is strobed at the falling edge of RxCLKIN. When the signal is high, the pixel data shall be valid to be displayed.
VS	Vertical Sync	The signal is synchronized to RxCLKIN .
HS	Horizontal Sync	The signal is synchronized to RxCLKIN .

Note: Output signals from any system shall be low or High-impedance state when VDD is off.



Product Specification

AU OPTRONICS CORPORATION

6.3 Integration Interface and Pin Assignment

6.3.1 Connector Description

Physical interface is described as for the connector on module.

These connectors are capable of accommodating the following signals and will be following components.

Connector Name / Designation	For Signal Connector
Manufacturer	IPEX
Type / Part Number	IPEX 20455-040E-12R
Mating Housing/Part Number	Mating of IPEX 20455-040E-12R or compatible

6.3.2 Pin Assignment

LVDS is a differential signal technology for LCD interface and high speed data transfer device.

Pin	Signal	Description
1	GND	Power Ground
2	VDD	+ 3.3V Power Supply
3	VDD	+ 3.3V Power Supply
4	V _{EDID}	+ 3.3V EDID Power
5	AGING	Aging Mode Power Supply
6	CLK _{EDID}	EDID Clock Input
7	DATA _{EDID}	EDID Data Input
8	RXIN0N	LVDS Differential Data Input
9	RXIN0P	LVDS Differential Data Input
10	GND	Power Ground
11	RXIN1N	LVDS Differential Data Input
12	RXIN1P	LVDS Differential Data Input
13	GND	Power Ground
14	RXIN2N	LVDS Differential Data Input
15	RXIN2P	LVDS Differential Data Input
16	GND	Power Ground
17	RXCLKINN	LVDS Differential Clock Input
18	RXCLKINP	LVDS Differential Clock Input
19	GND	Power Ground
20	NC	No Connection (Reserve)



Product Specification

AU OPTRONICS CORPORATION

Pin	Signal	Description
21	NC	No Connection (Reserve)
22	GND	Power Ground
23	NC	No Connection (Reserve)
24	NC	No Connection (Reserve)
25	GND	Power Ground
26	NC	No Connection (Reserve)
27	NC	No Connection (Reserve)
28	GND	Power Ground
29	NC	No Connection (Reserve)
30	NC	No Connection (Reserve)
31	VLED_GND	VLED_GND
32	VLED_GND	VLED_GND
33	VLED_GND	VLED_GND
34	NC	No Connection (Reserve)
35	S_PWMIN	PWM
36	LED_EN	LED_EN
37	NC	No Connection (Reserve)
38	VLED	VLED
39	VLED	VLED
40	VLED	VLED



Product Specification

AU OPTRONICS CORPORATION

Note1: Start from right side

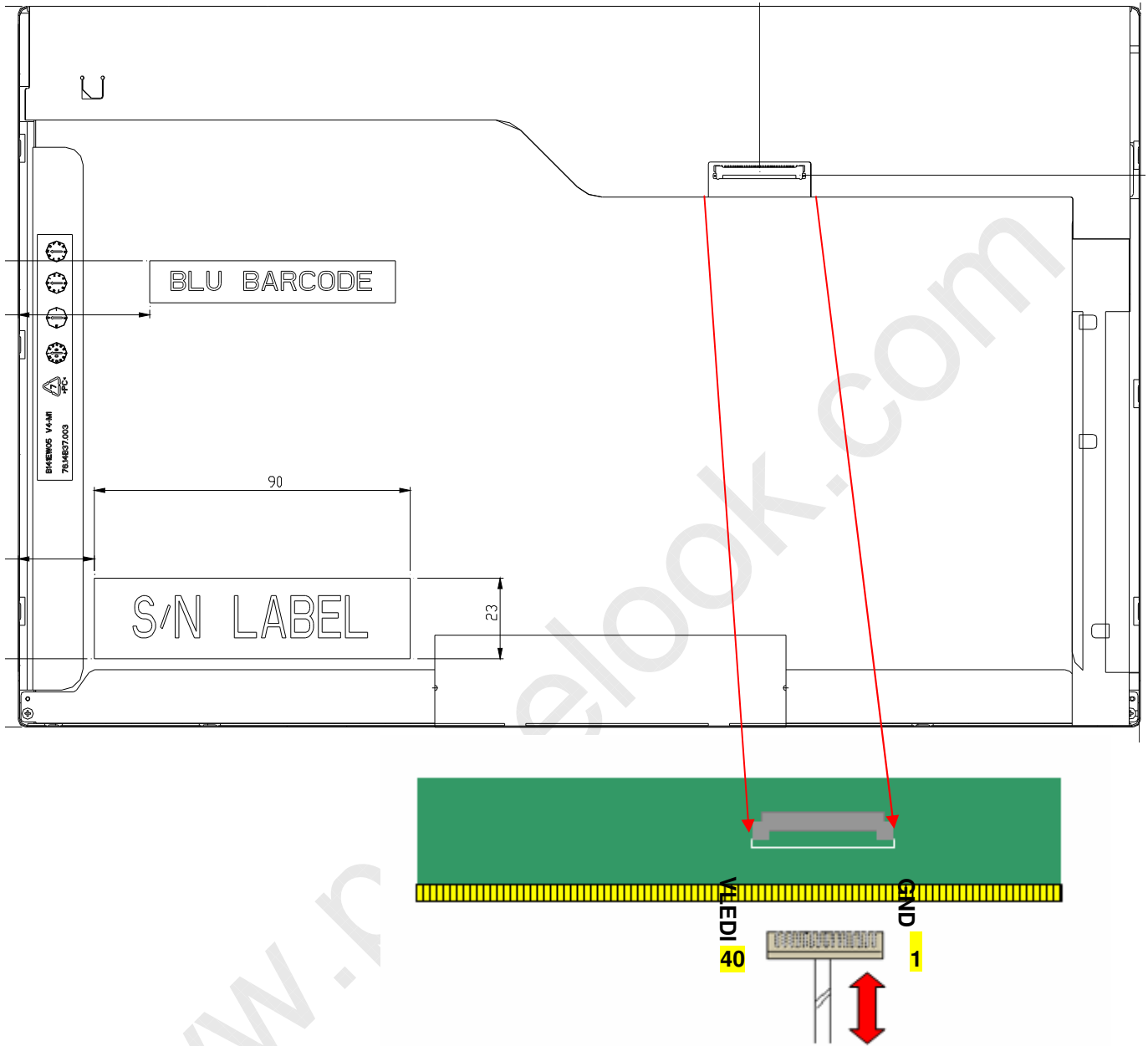

Note2: Input signals shall be low or High-impedance state when VDD is off.



Product Specification

AU OPTRONICS CORPORATION

6.4 Interface Timing

6.4.1 Timing Characteristics

Basically, interface timings should match the 1280x800 /60Hz manufacturing guide line timing.

Parameter	Symbol	Min.	Typ.	Max.	Unit	
Frame Rate	-	-	60.02	-	Hz	
Clock frequency	$1/T_{\text{Clock}}$	-	68.8	-	MHz	
Vertical Section	Period	T_V	808	820	1023	T_{Line}
	Active	T_{VD}	800	800	800	
	Blanking	T_{VB}	8	20	223	
Horizontal Section	Period	T_H	1310	1398	2047	T_{Clock}
	Active	T_{HD}	1280	1280	1280	
	Blanking	T_{HB}	30	118	767	

Note :

1. DE mode only

2. The designed minimum value of "frame rate" is 50Hz. When "frame rate" is set to be 40 Hz, the flicer syndrome may occur.

6.4.2 Timing diagram

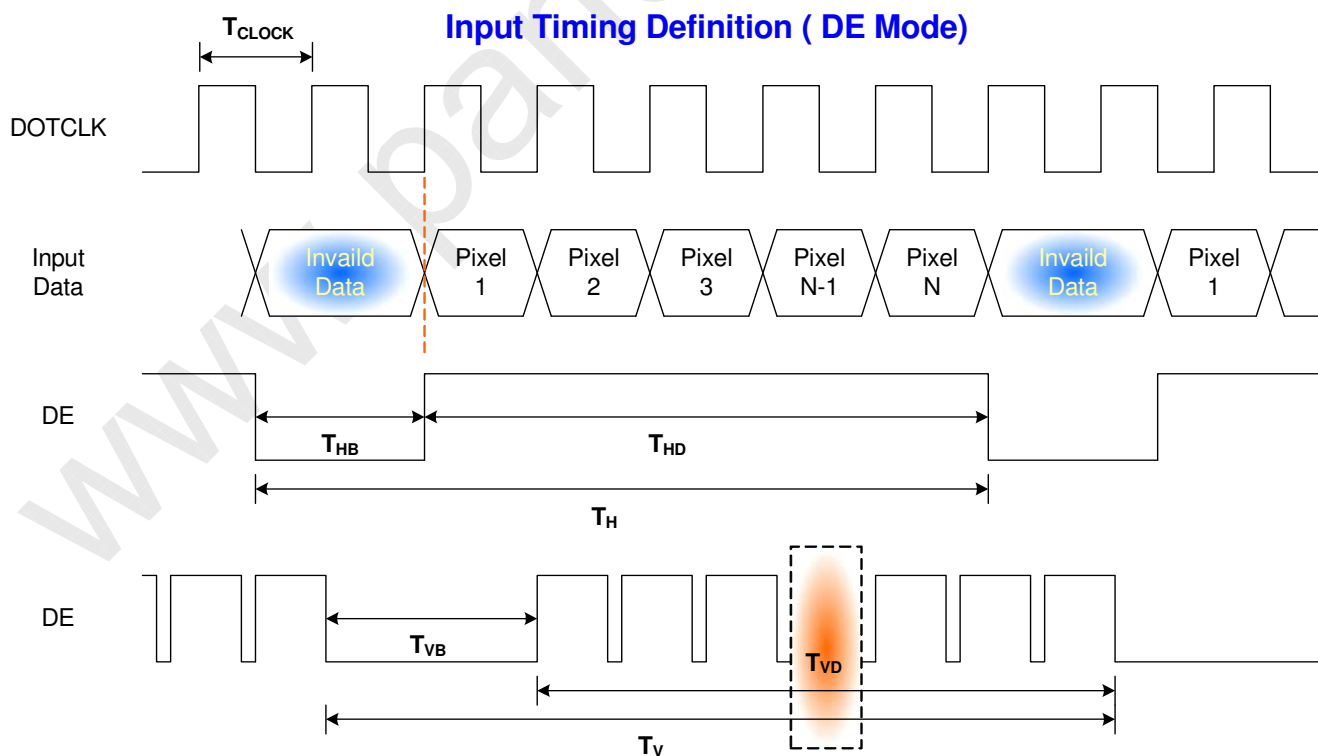



Product Specification

AU OPTRONICS CORPORATION

6.5 Power ON/OFF Sequence

- VDD power on/off sequence is as follows. Interface signals are also shown in the chart.
Signals from any system shall be Hi-Z state or low level when VDD is off
- LED on/off sequence is as follows. Interface signals are also shown in the chart.

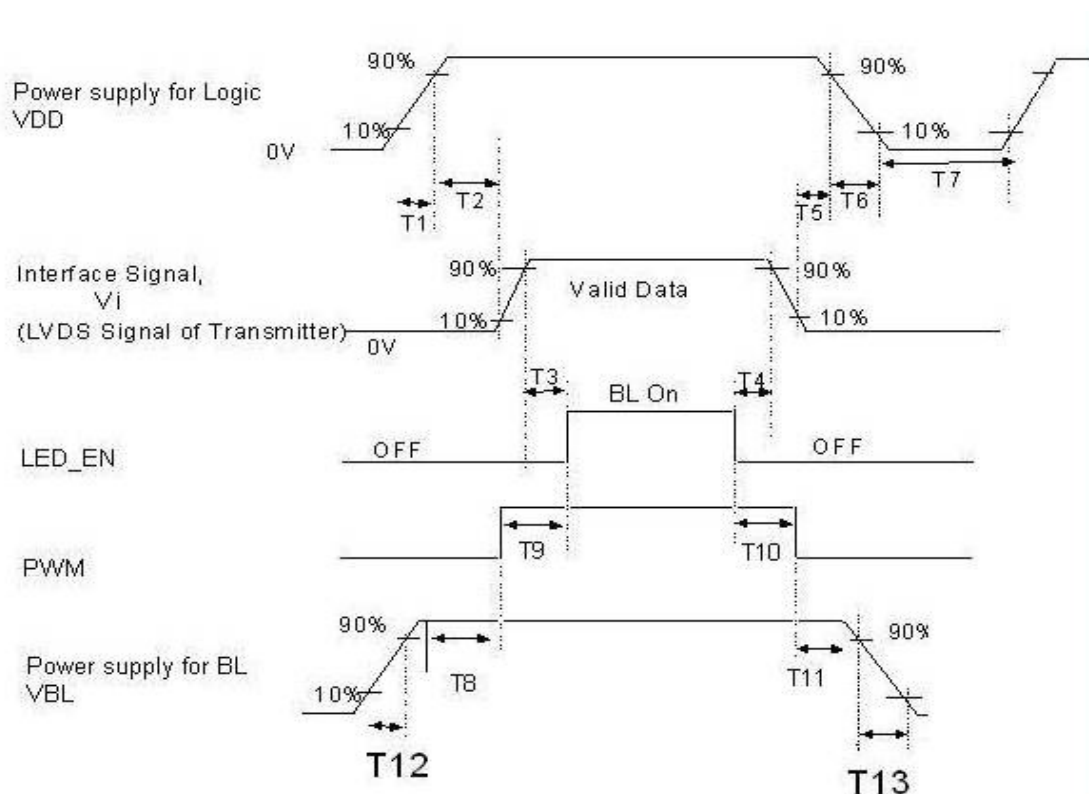

< Power sequence >	Min	Max	Unit
T1	0.5	10	ms
T2	0	50	ms
T3	200	-	ms
T4	0	-	ms
T5	0	-	ms
T6	0	10	ms
T7	150	-	ms
T8	0	-	ms
T9	0	-	ms
T10	0	-	ms
T11	0	-	ms
T12	0.5	-	
T13	0	-	



Product Specification

AU OPTRONICS CORPORATION

7. Vibration and Shock Test

7.1 Vibration Test

Test Spec:

- Test method: Non-Operation
- Acceleration: 1.5 G , Half sine pulse
- Frequency: 10 - 500Hz Sine wave
- Sweep: 30 Minutes each Axis (X, Y, Z)

7.2 Shock Test Spec:

Test Spec:

- Test method: Non-Operation
- Acceleration: 220 G , Half sine pulse
- Active time: 2 ms
- Pulse: X,Y,Z .one time for each side



Product Specification

AU OPTRONICS CORPORATION

7.3 Reliability Test

Items	Required Condition	Note
Temperature Humidity Bias	Ta= 40°C, 90%RH, 300h	
High Temperature Operation	Ta= 50°C, Dry, 300h	
Low Temperature Operation	Ta= 0°C, 300h	
High Temperature Storage	Ta= 60°C, 300h	
Low Temperature Storage	Ta= -20°C, 300h	
Thermal Shock Test	Ta=-20°C to 60°C, Duration at 30 min, 100 cycles	
ESD	Contact : ±8 KV Air : ±15 KV	Note 1

Note1: According to EN 61000-4-2 , ESD class B: Some performance degradation allowed. No data lost
Self-recoverable. No hardware failures.

Remark: MTBF (Excluding the LED): 30,000 hours with a confidence level 90%



Product Specification

AU OPTRONICS CORPORATION

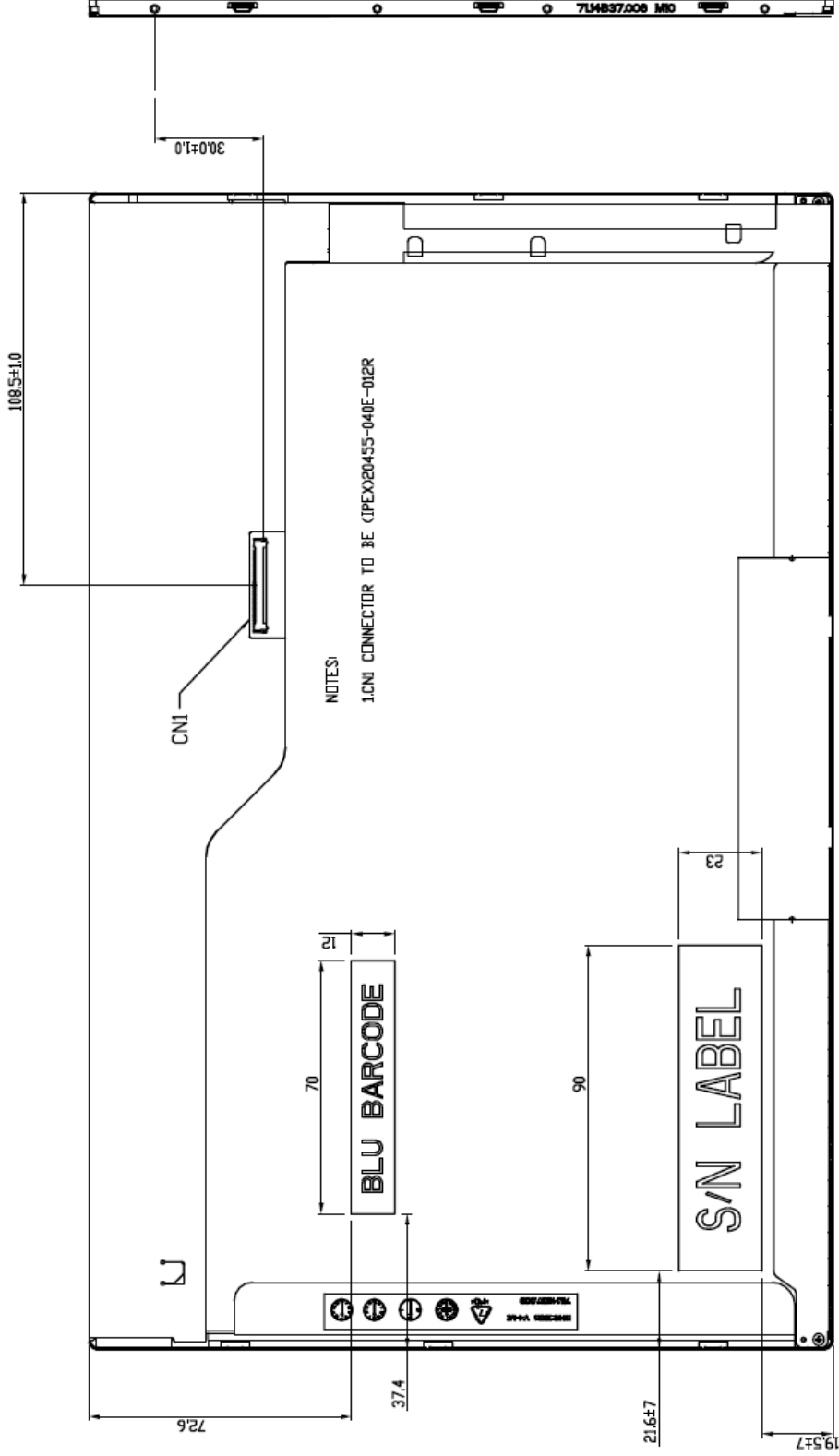



Product Specification

AU OPTRONICS CORPORATION

8.2 Screw Hole Depth and Center Position

Screw hole minimum depth, from side surface = 2.4 mm (See drawing)

Screw hole center location, from front surface = 3.1 ± 0.2 mm (See drawing)

Screw Torque: Maximum 2.5 kgf-cm

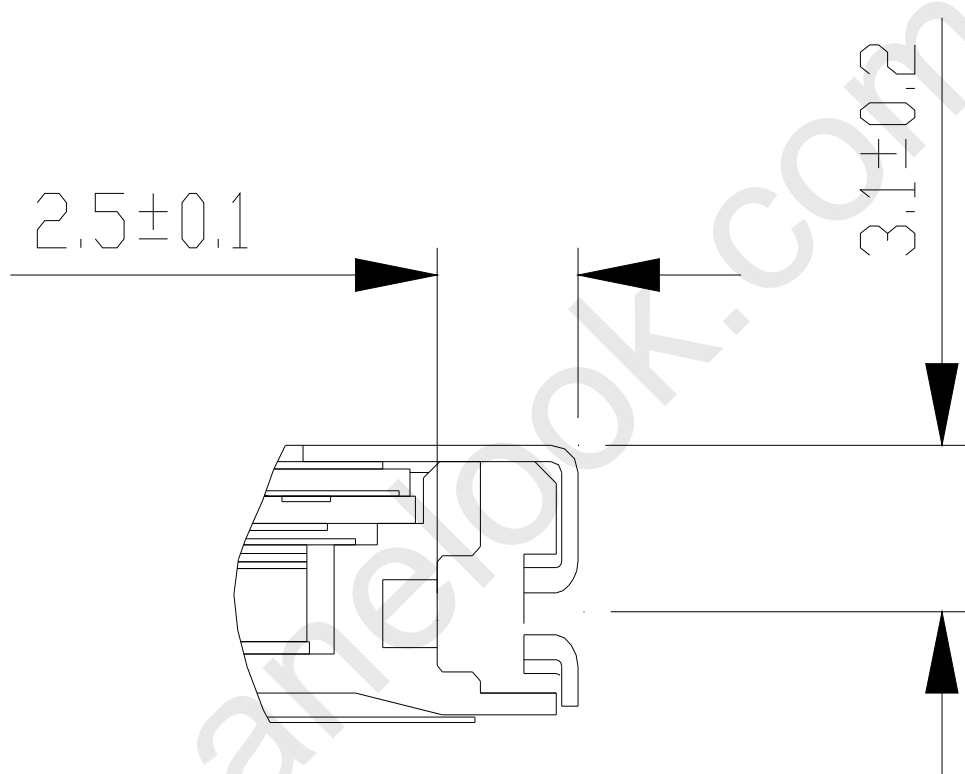



Product Specification

AU OPTRONICS CORPORATION

9. Shipping and Package

9.1 Shipping Label Format

 XXXXXXXXXXXX-XXXXX	Manufactured 06/35 Model No: B141EW05 V4 AU Optronics MADE IN CHINA (S1) H/W: 0A FW:1	C  US  0A00G E204356  
 11S42T0732Z1ZFYEC00000 902 P/N 42T0732 FRU 42T0733		



Product Specification

AU OPTRONICS CORPORATION

9.2 Carton package

The outside dimension of carton is 455 (L)mm x 380 (W)mm x 355 (H)mm

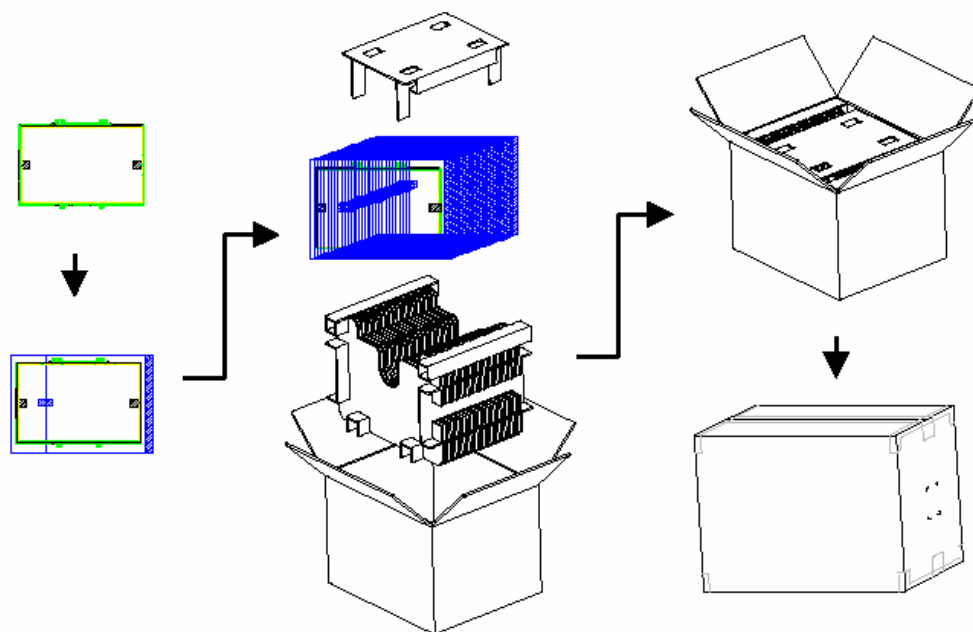

9.3 Shipping package of palletizing sequence

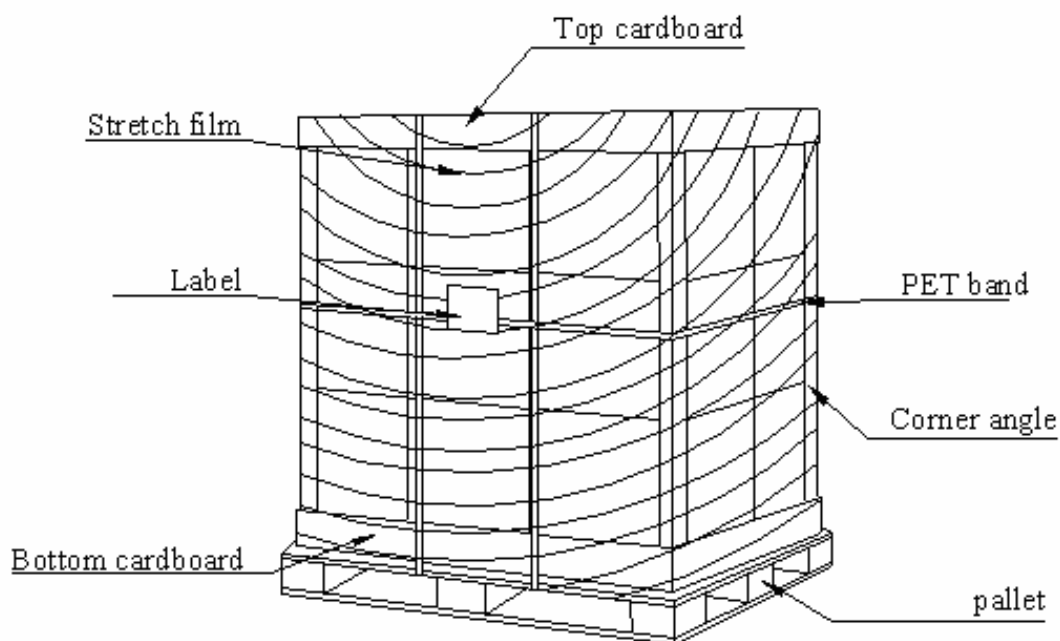



Product Specification

AU OPTRONICS CORPORATION

10. Appendix: EDID description

Byte#	Field Name and Comments	Value	Value	Value	Remarks
(HEX)		(Hex)	(Decimal)	(Binary)	
00	Header	00	0	00000000	
01	Header	FF	255	11111111	
02	Header	FF	255	11111111	
03	Header	FF	255	11111111	
04	Header	FF	255	11111111	
05	Header	FF	255	11111111	
06	Header	FF	255	11111111	
07	Header	00	0	00000000	
08	ID Manufacturer Name	30	48	00110000	LEN
09		AE	174	10101110	
0A	ID Product Code	35	53	00110101	14" 16:10 WXGA 1280x800 LED B/L
0B		40	64	01000000	
0C	ID Serial Number (32-bit serial number)	00	0	00000000	# 0
0D		00	0	00000000	
0E		00	0	00000000	
0F		00	0	00000000	
10	Week of Manufacture	01	1	00000001	1 weeks
11	Year of Manufacture	13	19	00010011	2009 years
12	EDID Structure version	01	1	00000001	Ver. 1.3
13	EDID Revision	03	3	00000011	
14	Video Input Definition	80	128	10000000	Digital
15	Max H Image Size(cm)	1E	30	00011110	30cm
16	Max V Image Size(cm)	13	19	00010011	19cm
17	Display gamma (gamma x 100)-100	78	120	01111000	2.20
18	Feature support(DPMS)				Standby , Suspend , Active Off/Very Low Power , RGB color display , Preferred Timing Mode
		EA	234	11101010	
19	Red/Green Low Bits	26	38	00100110	
1A	Blue/White Low Bits	75	117	01110101	
1B	Red x	96	150	10010110	0.586
1C	Red y	58	88	01011000	0.346
1D	Green x	57	87	01010111	0.341
1E	Green y	93	147	10010011	0.575
1F	Blue x	28	40	00101000	0.157
20	Blue y	1E	30	00011110	0.120
21	White x	50	80	01010000	0.313



Product Specification

AU OPTRONICS CORPORATION

22	White y	54	84	01010100	0.329
23	Established Timing 1	00	0	00000000	
24	Established Timing 2	00	0	00000000	
25	Manufacturer's Timings	00	0	00000000	
26	Standard Timing Identification #1	01	1	00000001	
27		01	1	00000001	
28	Standard Timing Identification #2	01	1	00000001	
29		01	1	00000001	
2A	Standard Timing Identification #3	01	1	00000001	
2B		01	1	00000001	
2C	Standard Timing Identification #4	01	1	00000001	
2D		01	1	00000001	
2E	Standard Timing Identification #5	01	1	00000001	
2F		01	1	00000001	
30	Standard Timing Identification #6	01	1	00000001	
31		01	1	00000001	
32	Standard Timing Identification #7	01	1	00000001	
33		01	1	00000001	
34	Standard Timing Identification #8	01	1	00000001	
35		01	1	00000001	
36	Pixel Clock/10,000 (LSB)	E0	224	11100000	68.8MHz (Refresh rate 60.016 Hz)
37	Pixel Clock/10,000 (MSB) /	1A	26	00011010	
38	Horizontal Active	00	0	00000000	1280 pixels
39	Horizontal Blanking	76	118	01110110	118 pixels
3A	Horizontal Active : Horizontal Blanking	50	80	01010000	
3B	Vertical Active	20	32	00100000	800 lines
3C	Vertical Blanking	14	20	00010100	20 lines
3D	Vertical Active : Vertical Blanking	30	48	00110000	
3E	Horizontal Sync. Offset	2D	45	00101101	45 pixels
3F	Horizontal Sync Pulse Width	20	32	00100000	32 pixels
40	Vertical Sync Offset : Sync Width	36	54	00110110	3 lines / 6 lines
41	Horizontal Vertical Sync Offset/Width upper 2bits	00	0	00000000	
42	Horizontal Image Size	2F	47	00101111	303 mm
43	Vertical Image Size	BD	189	10111101	189 mm
44	Horizontal & Vertical Image Size	10	16	00010000	
45	Horizontal Border	00	0	00000000	0 pixels
46	Vertical Border	00	0	00000000	0 lines
47	Flags	18	24	00011000	Non-interlaced , Normal display, no stereo , Digital separate , Vertical



Product Specification

AU OPTRONICS CORPORATION

					Polarity Negative , Horizontal Polarity Negative
48	Pixel Clock/10,000 (LSB) (Slow Refresh rate)	64	100	01100100	57.62MHz (Refresh rate 50 Hz)
49	Pixel Clock/10,000 (MSB) / (Slow Refresh rate)	16	22	00010110	
4A	Horizontal Active	00	0	00000000	1280 pixels
4B	Horizontal Blanking	76	118	01110110	118 pixels
4C	Horizontal Active : Horizontal Blanking	50	80	01010000	
4D	Vertical Active	20	32	00100000	800 lines
4E	Vertical Blanking	14	20	00010100	20 lines
4F	Vertical Active : Vertical Blanking	30	48	00110000	
50	Horizontal Sync. Offset	2D	45	00101101	45 pixels
51	Horizontal Sync Pulse Width	20	32	00100000	32 pixels
52	Vertical Sync Offset : Sync Width	36	54	00110110	3 lines / 6 lines
53	Horizontal Vertical Sync Offset/Width upper 2bits = 0	00	0	00000000	
54	Horizontal Image Size	2F	47	00101111	303 mm
55	Vertical Image Size	BD	189	10111101	189 mm
56	Horizontal & Vertical Image Size	10	16	00010000	
57	Horizontal Border	00	0	00000000	0 pixels
58	Vertical Border	00	0	00000000	0 lines
59	Flags	18	24	00011000	Non-interlaced , Normal display, no stereo , Digital separate , Vertical Polarity Negative , Horizontal Polarity Negative
5A	Flag	00	0	00000000	
5B	Flag	00	0	00000000	
5C	Flag	00	0	00000000	
5D	Data Type Tag	0F	15	00001111	Description defined by manufacture
5E	Flag	00	0	00000000	
5F	(Horizontal active pixel /8)-31	81	129	10000001	1280 pixel
60	Image Aspect Ratio	0A	10	00001010	16 : 10
61	Middle Refresh Rate	32	50	00110010	50 Hz
62	(Horizontal active pixel /8)-31	81	129	10000001	1280 pixel
63	Image Aspect Ratio	0A	10	00001010	16 : 10
64	Low Refresh Rate	28	40	00101000	40 Hz
65	Brightness(1/10nit)	16	22	00010110	220 nit
66	Feature flag	09	9	00001001	TN, White LED backlight,
67	Reserved	00	0	00000000	



Product Specification

AU OPTRONICS CORPORATION

68	LCD Supplier manufacture Code (3 character ID)	06	6	00000110	AUO
69		AF	175	10101111	
6A	LCD Supplier Product code	56	86	01010110	
6B	LCD Supplier Product code	34	52	00110100	
6C	Flag	00	0	00000000	
6D	Flag	00	0	00000000	
6E	Flag	00	0	00000000	
6F	Data Type Tag	FE	254	11111110	ASCII String
70	Flag	00	0	00000000	
71	Model Name	42	66	01000010	[B]
72	Model Name	31	49	00110001	[1]
73	Model Name	34	52	00110100	[4]
74	Model Name	31	49	00110001	[1]
75	Model Name	45	69	01000101	[E]
76	Model Name	57	87	01010111	[W]
77	Model Name	30	48	00110000	[0]
78	Model Name	35	53	00110101	[5]
79	Model Name	20	32	00100000	[]
7A	Model Name	56	86	01010110	[V]
7B	Model Name	34	52	00110100	[4]
7C	Model Name	20	32	00100000	[]
7D	Model Name	0A	10	00001010	[^]
7E	Extension flag	00	0	00000000	
7F	Checksum	9D	157	10011101	