



Product Specification

AU OPTRONICS CORPORATION

B150XG07 V3

() Preliminary Specifications

(V) Final Specifications

Module	15" XGA Color TFT-LCD
Model Name	B150XG07 V3(QD15XL0404)

Customer	Date
_____	_____
Checked & Approved by	
_____	_____
<p>Note: This Specification is subject to change without notice.</p>	

Approved by	Date
Jaff Huang	2007/09/12
Prepared by	
Jaff Huang	2007/09/12
<p>MDBU Marketing Division / AU Optronics corporation</p>	



Product Specification

1

AU OPTRONICS CORPORATION

B150XG07 V3

These specification sheets are the proprietary product of AU Optronics ("AUO") and include materials protected under copyright of AUO. Do not reproduce or cause any third party to reproduce them in any form or by any means, electronic or mechanical, for any purpose, in whole or in part, without the express written permission of AUO.

The device listed in these technical literature sheets was designed and manufactured for use in OA equipment.

In case of using the device for applications such as control and safety equipment for transportation (aircraft, trains, automobiles, etc.), rescue and security equipment and various safety related equipment which require higher reliability and safety, take into consideration that appropriate measures such as fail-safe functions and redundant system design should be taken.

Do not use the device for equipment that requires an extreme level of reliability, such as aerospace applications, telecommunication equipment (trunk lines), nuclear power control equipment and medical or other equipment for life support.

AUO assumes no responsibility for any damage resulting from the use of the device which does not comply with the instructions and the precautions specified in these technical literature sheets.

Contact and consult with a AUO sales representative for any questions about this device.



Product Specification

AU OPTRONICS CORPORATION

B150XG07 V3

Revision History			
REV.	Date	ECN NO.	Change Content
0	08/19/2005	N/A	Specification Initial Release
1	09/12/2007	N/A	QDI model name transform to AU model name

www.panelook.com



Product Specification

AU OPTRONICS CORPORATION

B150XG07 V3

1. Application

This specification applies to a color TFT-LCD module, B150XG07 V3(QD15XL0403).

2. Overview

This module is a color active matrix LCD module incorporating amorphous silicon TFT (Thin Film Transistor). It is composed of a color TFT-LCD panel, driver ICs, control circuit, and power supply circuit and a backlight unit. Graphics and texts can be displayed on a 1024 x3x768 dots panel with 262,144 colors by using LVDS (Low Voltage Differential Signaling) to interface and supplying +3.3V DC supply voltage for TFT-LCD panel driving and supply voltage for backlight.

The TFT-LCD panel used for this module has very high aperture ratio. A low-reflection and higher-color-saturation type color filter is also used for this panel. Therefore, high-brightness and high-contrast image, which is suitable for the multimedia use, can be obtained by using this module.

Optimum viewing direction is 6 o'clock.

[Features]

- 1) High aperture panel; high-brightness or low power consumption.
- 2) Brilliant and high contrast image.
- 3) Small footprint and thin shape.
- 4) Light weight.
- 5) 100% SPWG, style B
- 6) Lead-Free & RoHS Compliant

3. Mechanical Specifications

Parameter	Specifications	Unit
Display size	15" Diagonal	inch
Active area	304.13x228.10	mm
Pixel format	1024 (H)x768 (V)	Pixel
	(1 pixel = R+G+B dots)	
Pixel pitch	0.297(H) × 0.297 (V)	mm
Pixel configuration	R, G, B vertical stripe	
Display mode	Normally white	
Unit outline dimensions (typ.)*1	317.3(W)x242.0 (H)x5.9(D) 6.0 Max	mm
Mass	575 max. with inverter	g
Surface treatment	Anti-glare and hard-coating 3H Low reflection (~5%)	

*1.Note: excluding backlight cables. Outline dimensions is shown in this specification



Product Specification

4

AU OPTRONICS CORPORATION

B150XG07 V3

4. Input Terminals

4-1. TFT-LCD panel driving

CN1 (1 channel, LVDS signals – NSC/Ti standard and +3.3V DC power supply)

Using connector: FI-XB30Sx-HFxx/FI-X30Sx-HFxx/equivalent (JAE)

Interface Cable Pin Assignments

PIN NO	. SYMBOL	FUNCTION
1	VSS	Ground
2	VDD	Power Supply, 3.3 V (typical)
3	VDD	Power Supply, 3.3 V (typical)
4	V EEDID	DDC 3.3V power
5	TEST	Panel BIST Enable
6	Clk EEDID	DDC Clock
7	DATA EEDID	DDC Data
8	Rin0-	- LVDS differential data input (R0-R5, G0) (odd pixels)
9	Rin0+	+ LVDS differential data input (R0-R5, G0) (odd pixels)
10	VSS	Ground
11	Rin1-	- LVDS differential data input (G1-G5, B0-B1) (odd pixels)
12	Rin1+	+ LVDS differential data input (G1-G5, B0-B1) (odd pixels)
13	VSS	Ground
14	Rin2-	- LVDS differential data input (B2-B5, HS, VS, DE) (odd pixels)
15	Rin2+	+ LVDS differential data input (B2-B5, HS, VS, DE) (odd pixels)
16	VSS	Ground
17	ClkIN-	- LVDS differential clock input (odd pixels)
18	ClkIN+	+ LVDS differential clock input (odd pixels)
19	VSS	Ground
20	NC	No connect
21	NC	No connect
22	NC	No connect
23	NC	No connect
24	NC	No connect
25	NC	No connect
26	NC	No connect
27	NC	No connect
28	NC	No connect
29	NC	No connect
30	NC	No connect

[Note 1] Relation between LVDS signals and actual data shows below section (4-2).

[Note 2] The shielding case is connected with signal GND.

Using receiver : DS90CF364(National semiconductor) Corresponding Transmitter : DS90C363,DS90C383(National semiconductor)

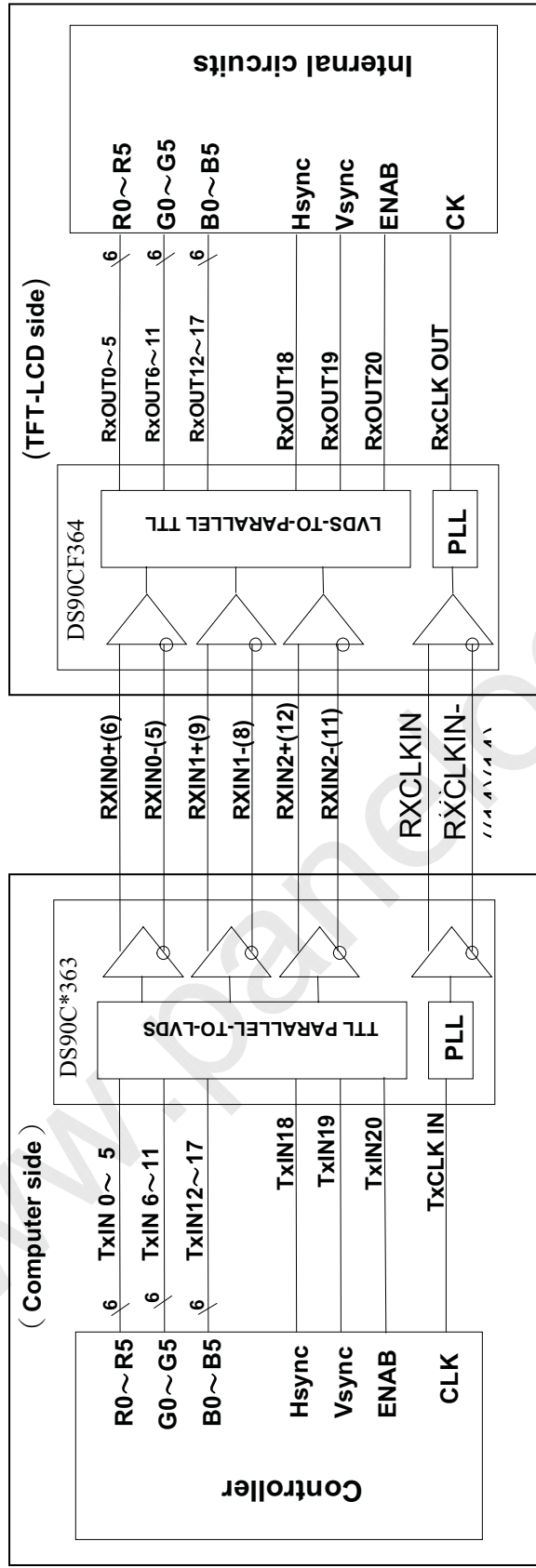



Product Specification

AU OPTRONICS CORPORATION

B150XG07 V3

4-3. Inverter connector pin assign

CN3:(Inverter signals and Inverter Power Supply)

Using connector: LVC-D20SYFG (HONDA)

Corresponding connector: LVC-D20LVM-SG (HONDA)

Pin no.	Symbol	Function
1,2,3	INV SRC	Input voltage
4	N.C	No connect
5,8,11,13	GND	Ground
6	5VSUS	System +5V voltage (Inverter no use)
7	5VALW	Dallas IC VCC Voltage
9	SDA	Brightness control data signal (SMBUS DATA)
10	SCL	Brightness control clock signal (SMBUS CLOCK)
12	FPVEE	MPS IC Enable voltage
14	LAMP_STAT	Lamp Status
15	N.C.	No connect
16	N.C.	No connect
17	N.C.	No connect
18	N.C.	No connect
19	N.C.	No connect
20	N.C.	No connect

5. Absolute Maximum Ratings

5-1 LCD module

Parameter	Symbol	Condition	Ratings	Unit	Remark
Input voltage	V_I	$T_a=25^{\circ}\text{C}$	$-0.3 \sim V_{DD}+0.3$	V	[Note1]
+3.3V supply voltage	VDD	$T_a=25^{\circ}\text{C}$	$0 \sim +4$	V	
Storage temperature	Tstg	—	$-25 \sim +60$	$^{\circ}\text{C}$	[Note2]
Operating temperature (Ambient)	Topa	—	$0 \sim +50$	$^{\circ}\text{C}$	

[Note1] LVDS signals

[Note2] Humidity : 95%RH Max. at $T_a \leq 40^{\circ}\text{C}$.

Maximum wet-bulb temperature at 39°C or less at $T_a > 40^{\circ}\text{C}$.

No condensation.

5-2 Inverter driving

5-2.1 Backlight lifetime

The backlight system is an edge-lighting type with single CCFT (Cold Cathode Fluorescent Tube).

The lifetime of the lamp are shown in the following table.



Product Specification

7

AU OPTRONICS CORPORATION

B150XG07 V3

Parameter	Symbol	Min.	Typ.	Max.	Unit	Remark
Lamp life time	LL	10000	15000	-	Hour	[Note]

[Note] Lamp life time is defined as the time when • occurs in the continuous operation under the condition of $T_a = 25^\circ\text{C}$ and SDA data=00HEX

- Brightness becomes 50% of the original value under standard condition.

5-2.2 Recommended Operation Condition

Parameter	Symbol	Min.	Typ	Max	Unit
Inverter power supply voltage	Vin	7.5	-	21	V
Base of Brightness control voltage	VBB	4.85	5.0	5.2	V
Brightness control IC supply voltage	VBC	4.5	5.0	5.5	V
Logic signals	SDA, SCL FPVEE	0		5	V

5-2.3 DC Electrical Conditions

 $T_a=25^\circ\text{C}$

Parameter	Symbol	Condition	Min.	Typ	Max	Unit	Remark	
VIN supply current	IVin	VIN=7.5V,VBB=5V	-	450	585	mA	Note	
		VIN=21V,VBB=5V	200	-	300			
Brightness control IC supply current	IVbc	VBC=4.5~5.5V	-	-	200	uA		
SDA SCL	Input voltage low	Vil	VBC=4.5~5.5V	-	-	$0.3 \times$ VBC	V	
	Input voltage high	Vih	VBC=4.5~5.5V	$0.7 \times$ VBC	-	-	V	
FPVEE	Input voltage low	Vil	VIN=7.5~21V	0	-	0.6	V	
	Input voltage high	Vih	VIN=7.5~21V	3.0	-	5.0	V	

Note: Brightness control from minmum to maximum



Product Specification

8

AU OPTRONICS CORPORATION

B150XG07 V3

5-2.4. Power ON/OFF sequence

$$7.5V \leq V_{in} < 21V$$

$$10ms \leq t_d$$

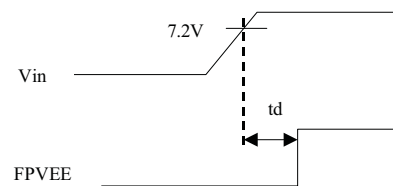

5-2.5 FPVee ON sequence

Backlight power on/off is possible with FPVee.

Make sure to have more than 50-millisecond interval between each power-on.

$$50ms \leq t_1$$

$$t_2 \leq 20ms$$

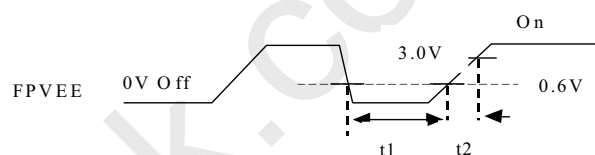

5-2.6 The Condition of Shut Down

Please refer to the figure below for the conditions that will cause the inverter shut down.

If the V_{in} voltage is higher than 8.0V but there is no enable signal, then the inverter will shut down.

If the V_{in} voltage is down less than 8.0V, it will cause the inverter shut down.

The enable signal has to be reset to get the inverter started again.

5-2.7 Brightness Control

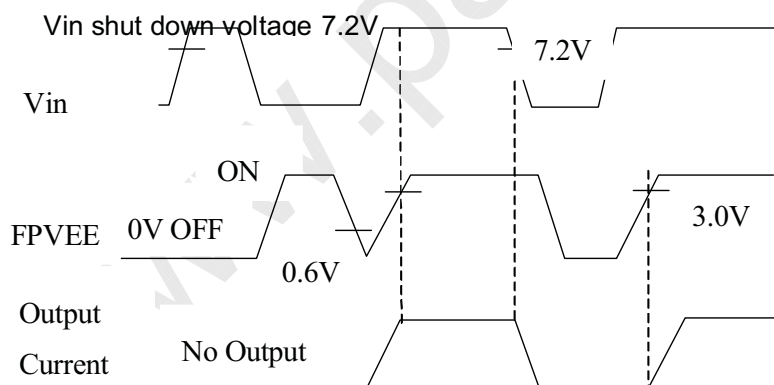

SDA data	Brightness	Notes
00HEX	Maximum Brightness	Set on power-up
01~FEHEX	↓	
FFHEX	Minimum Brightness	



Product Specification

9

AU OPTRONICS CORPORATION

B150XG07 V3

6. Electrical Characteristics

6-1. TFT-LCD panel driving

Ta = 25°C

Parameter		Symbol	Min.	Typ.	Max.	Unit	Remark
VDD	Supply voltage	VDD	+3.0	+3.3	+3.6	V	[Note2]
	Current dissipation	IDD	—	350	485	m A	[Note3]
Permissible input ripple voltage		V _{RP}	—	—	100	mV p-p	V _{CC} =+3.3V
Differential input Threshold voltage	High	V _{TH}	—	—	+100	mV	V _{CM} =+1.2V [Note1]
	Low	V _{TL}	-100	—	—	mV	
Terminal resistor		R _T	—	100	—	Ω	Differential input
Rush current		I _{RUSH}	—	—	1.5	A	Rise time 470uS

[Note1] V_{CM} : Common mode voltage of LVDS driver.

[Note2]

On-off conditions for supply voltage

$$0 < t_1 \leq 10 \text{ ms}$$

$$0 < t_2 \leq 50 \text{ ms}$$

$$0 < t_3 \leq 50 \text{ ms}$$

$$400 \text{ ms} \leq t_4 ; 200 \text{ ms} \leq t_5 ; 200 \text{ ms} \leq t_6$$

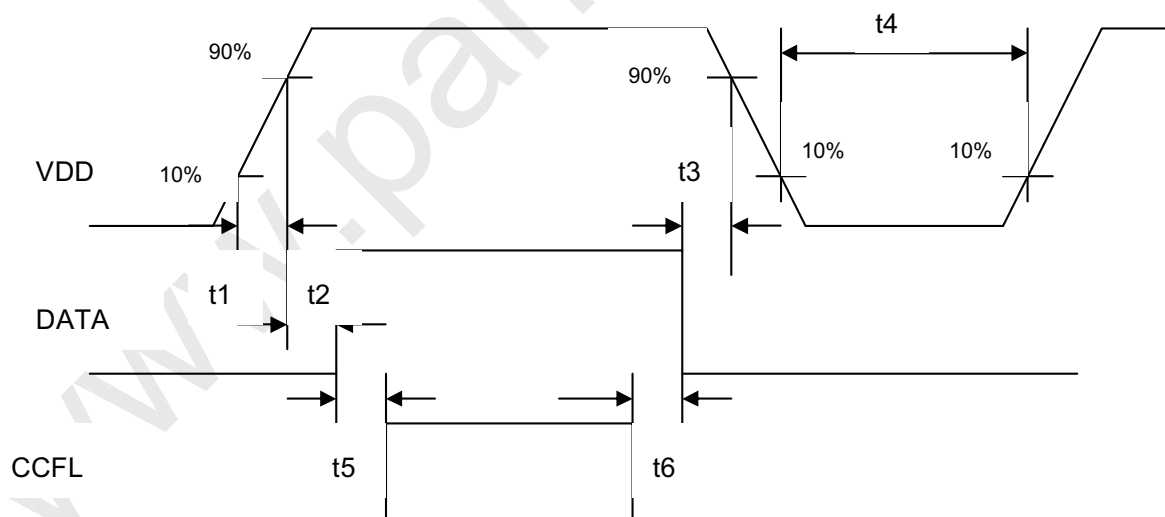



Product Specification

10

AU OPTRONICS CORPORATION

B150XG07 V3

VDD-dip conditions

- 1) $2.5\text{ V} \leq \text{VDD} < 3.0\text{ V}$
 $t_d \leq 10\text{ ms}$
- 2) $\text{VDD} < 2.5\text{ V}$

VDD-dip conditions should also

follow the On-off conditions for supply voltage

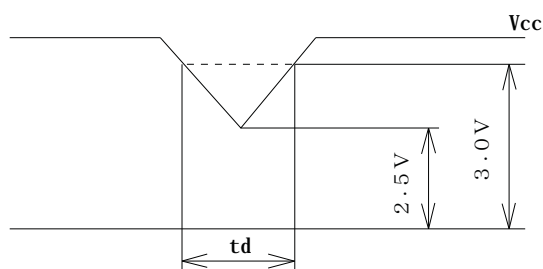

[Note3] Typical current situation: 16-gray-bar pattern.

VDD=+3.3V

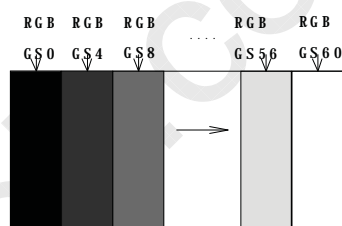



Product Specification

11

AU OPTRONICS CORPORATION

B150XG07 V3

6-2. Backlight driving

The backlight system is an edge-lighting type with single CCFT (Cold Cathode Fluorescent Tube).

The characteristics of the lamp are shown in the following table.

Parameter	Symbol	Min.	Typ.	Max.	Unit	Remark
Lamp current range	I_L	2.0	6.0	7.0	mArms	[Note1]
Lamp voltage	V_L		660		Vrms	
Lamp power consumption	P_L	—	3.96		W	$I_L=6.0\text{mA}$ [Note2]
Lamp frequency	F_L	50	55	60	kHz	[Note3]
Kick-off voltage	V_s	—	—	1350	Vrms	$T_a=25^\circ\text{C}$
		—	—	1500	Vrms	$T_a=0^\circ\text{C}$ [Note4]
Lamp life time	L_L	10000	15000	—	hour	[Note5]

[Note1] Lamp current is measured with current meter for high frequency as shown below.

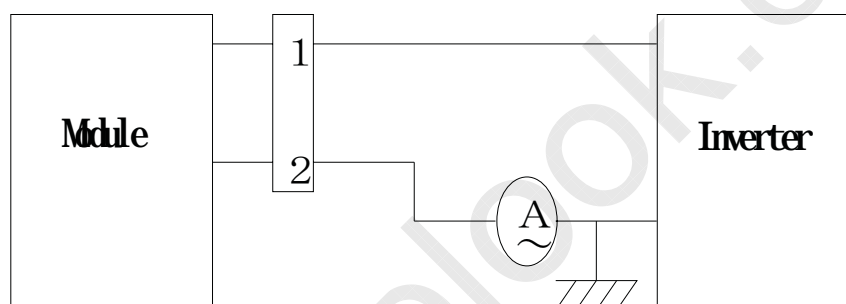

* Pin2 is V_{LOM}

[Note2] Calculated Value for reference ($I_L \times V_L$)

[Note3] Lamp frequency may produce interference with horizontal synchronous frequency, and this may cause beat on the display. Therefore lamp frequency shall be detached as much as possible from the horizontal synchronous frequency and from the harmonics of horizontal synchronous to avoid interference.

[Note4] The voltage above this value should be applied to the lamp for more than 1 second to start-up. Otherwise the lamp may not be turned on.

[Note5] Lamp life time is defined as the time when either ① or ② occurs in the continuous operation under the condition of $T_a = 25^\circ\text{C}$ and $I_L = 6.0 \text{ mArms}$.

- ① Brightness becomes 50 % of the original value under standard condition.
- ② Kick-off voltage at $T_a = 0^\circ\text{C}$ exceeds maximum value.

Note) The performance of the backlight, for example life time or brightness, is much influenced by the characteristics of the DC-AC inverter for the lamp. When you design or order the inverter, please make sure that a poor lighting caused by the mismatch of the backlight and the inverter (miss-lighting, flicker, etc.) never occur. When you confirm it, the module should be operated in the same condition as it is installed in your instrument.



Product Specification

AU OPTRONICS CORPORATION

B150XG07 V3

7. Timing characteristics of LCD module input signals

7-1. Timing characteristics

(This is specified at digital outputs of LVDS driver.)

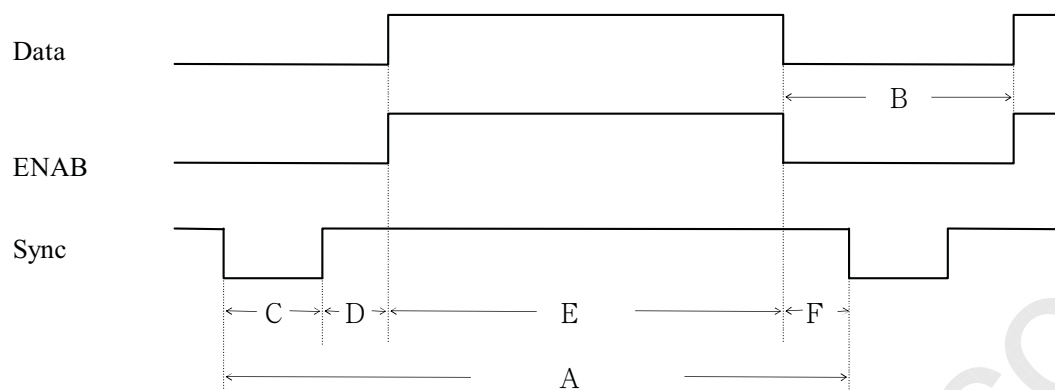

(Vertical)

Item (symbol)	Min.	Typ.	Max.	Unit	Remark
Vsync cycle (T_{VA})	—	16.667	—	ms	Negative
	803	806	—	line	
Blanking period (T_{VB})	35	38	—	line	
Sync pulse width (T_{VC})	4	6	—	line	
Back porch (T_{VD})	0	29	—	line	
Sync pulse width + Back porch ($T_{VC}+T_{VD}$)	35	35	35	line	
Active display area (T_{VE})	768	768	768	line	
Front porch (T_{VF})	0	3	—	line	

(Horizontal)

Item (symbol)	Min.	Typ.	Max.	Unit	Remark
Hsync cycle (T_{HA})	19.2	20.677	—	μs	Negative
	1260	1344	1408	clock	
Blanking period (T_{HB})	236	320	—	clock	
Sync pulse width (T_{HC})	8	136	—	clock	
Back porch (T_{HD})	0	160	312	clock	
Sync pulse width + Back porch ($T_{HC}+T_{HD}$)	$1500 - T_{HA}$	296	$T_{HA} - 1024$	clock	
Active display area (T_{HE})	1024	1024	1024	clock	
Front porch (T_{HF})	8	24	—	clock	

(Clock)

Item	Min.	Typ.	Max.	Unit	Remark
Frequency	—	65.0	68.0	MHz	[Note]

Note) In case of lower frequency, the deterioration of display quality, flicker etc., may be occurred.



Product Specification

AU OPTRONICS CORPORATION

B150XG07 V3

7-2. Input Data Signals and Display Position on the screen

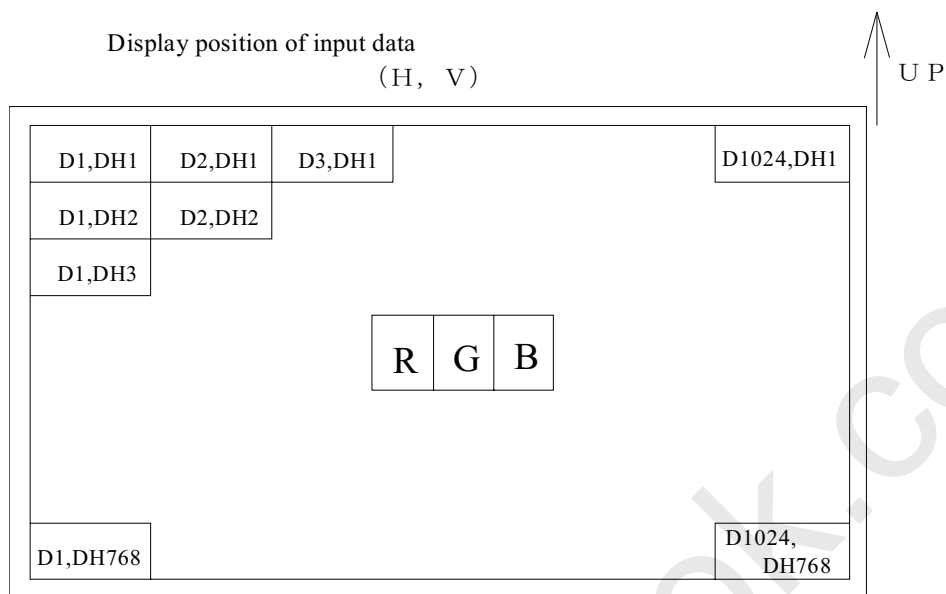



Product Specification

AU OPTRONICS CORPORATION

B150XG07 V3

8. Input Signals, Basic Display Colors and Gray Scale of Each Color & EDID Data Structure

Colors & Gray scale	Data signal																			
	Gray Scale	R0	R1	R2	R3	R4	R5	G0	G1	G2	G3	G4	G5	B0	B1	B2	B3	B4	B5	
Basic Color	Black	—	0	0	0	0	0	0	0	0	0	0	0	0	0	0	0	0	0	0
	Blue	—	0	0	0	0	0	0	0	0	0	0	0	0	1	1	1	1	1	1
	Green	—	0	0	0	0	0	0	1	1	1	1	1	1	0	0	0	0	0	0
	Cyan	—	0	0	0	0	0	0	1	1	1	1	1	1	1	1	1	1	1	1
	Red	—	1	1	1	1	1	1	0	0	0	0	0	0	0	0	0	0	0	0
	Magenta	—	1	1	1	1	1	1	0	0	0	0	0	0	1	1	1	1	1	1
	Yellow	—	1	1	1	1	1	1	1	1	1	1	1	1	0	0	0	0	0	0
	White	—	1	1	1	1	1	1	1	1	1	1	1	1	1	1	1	1	1	1
Gray Scale of Red	Black	GS0	0	0	0	0	0	0	0	0	0	0	0	0	0	0	0	0	0	0
	↑	GS1	1	0	0	0	0	0	0	0	0	0	0	0	0	0	0	0	0	0
	Darker	GS2	0	1	0	0	0	0	0	0	0	0	0	0	0	0	0	0	0	0
	↑	↓				↓					↓						↓			
	↓	↓				↓					↓						↓			
	Brighter	GS61	1	0	1	1	1	1	0	0	0	0	0	0	0	0	0	0	0	0
	↓	GS62	0	1	1	1	1	1	0	0	0	0	0	0	0	0	0	0	0	0
	Red	GS63	1	1	1	1	1	1	0	0	0	0	0	0	0	0	0	0	0	0
Gray Scale of Green	Black	GS0	0	0	0	0	0	0	0	0	0	0	0	0	0	0	0	0	0	0
	↑	GS1	0	0	0	0	0	0	1	0	0	0	0	0	0	0	0	0	0	0
	Darker	GS2	0	0	0	0	0	0	0	1	0	0	0	0	0	0	0	0	0	0
	↑	↓				↓					↓						↓			
	↓	↓				↓					↓						↓			
	Brighter	GS61	0	0	0	0	0	0	1	0	1	1	1	1	0	0	0	0	0	0
	↓	GS62	0	0	0	0	0	0	0	1	1	1	1	1	0	0	0	0	0	0
	Green	GS63	0	0	0	0	0	0	1	1	1	1	1	1	0	0	0	0	0	0
Gray Scale of Blue	Black	GS0	0	0	0	0	0	0	0	0	0	0	0	0	0	0	0	0	0	0
	↑	GS1	0	0	0	0	0	0	0	0	0	0	0	0	1	0	0	0	0	0
	Darker	GS2	0	0	0	0	0	0	0	0	0	0	0	0	0	1	0	0	0	0
	↑	↓				↓					↓						↓			
	↓	↓				↓					↓						↓			
	Brighter	GS61	0	0	0	0	0	0	0	0	0	0	0	0	1	0	1	1	1	1
	↓	GS62	0	0	0	0	0	0	0	0	0	0	0	0	0	1	1	1	1	1
	Blue	GS63	0	0	0	0	0	0	0	0	0	0	0	0	1	1	1	1	1	1

0 : Low level voltage, 1 : High level voltage

Each basic color can be displayed in 64 gray scales from 6 bit data signals.

According to the



Product Specification

AU OPTRONICS CORPORATION

B150XG07 V3

combination of total 18 bit data signals, the 262,144-color display can be achieved on the screen.

www.panelook.com



Product Specification

AU OPTRONICS CORPORATION

B150XG07 V3

9. EDID data structure

QD15XL040301 EDID data structure (5/16/2005).

This is the EDID (Extended Display Identification Data) data format to support displays as defined in the VESA Plug & Display.

Byte (decimal)	Byte (hex)	Field Name and Comments	Value (hex)	Value (binary)
0	00	Header	00	00000000
1	01	Header	FF	11111111
2	02	Header	FF	11111111
3	03	Header	FF	11111111
4	04	Header	FF	11111111
5	05	Header	FF	11111111
6	06	Header	FF	11111111
7	07	Header	00	00000000
8	08	EISA manufacture code = QDS	44	01000100
9	09	EISA manufacture code (Compressed ASCII)	93	10010011
10	0A	Product code: 0068 (N15B9)	44	01000100
11	0B	Product code	00	00000000
12	0C	LCD module Serial No (fixed "0")	00	00000000
13	0D	LCD module Serial No (fixed "0")	00	00000000
14	0E	LCD module Serial No (fixed "0")	00	00000000
15	0F	LCD module Serial No (fixed "0")	00	00000000
16	10	Week of manufacture	00	00000000
17	11	Year of manufacture – 1990 (ex2000-1990=10), 2005-1990=15=E (hex)	0F	00001111
18	12	EDID structure version # = 1	01	00000001
19	13	EDID revision # = 3	03	00000011
20	14	Video I/P definition = Digital I/P	80	10000000
21	15	Max H image size (cm) = 30cm	1E	00011110
22	16	Max V image size (cm) = 23cm	17	00010111
23	17	Display gamma (2.2 × 100) –100= 120	78	01111000
24	18	Feature support (no DMPS, Active off, RGB, timing BLK1)	0A	00001010
25	19	Red/Green Low bit	47	01000111
26	1A	Blue/White Low bit	A0	10100000
27	1B	Red X (Rx)(written value "0.580")	94	10010100
28	1C	Red Y (Ry)(written value "0.340")	57	01010111
29	1D	Green X (Gx)(written value "0.310")	4F	01001111
30	1E	Green Y (Gy)(written value "0.550")	8C	10001100
31	1F	Blue X (Bx)(written value "0.155")	27	00100111
32	20	Blue Y (By)(written value "0.155")	27	00100111
33	21	White X (Wx)(written value "0.313")	50	01010000
34	22	White Y (Wy)(written value "0.329")	54	01010100
35	23	Established timings 1	00	00000000
36	24	Established timings 2	00	00000000
37	25	Established timings 3 (Manufacture's reserved timing)	00	00000000
38	26	Standard timing ID1	01	00000001
39	27	Standard timing ID1	01	00000001
40	28	Standard timing ID2	01	00000001
41	29	Standard timing ID2	01	00000001
42	2A	Standard timing ID3	01	00000001
43	2B	Standard timing ID3	01	00000001
44	2C	Standard timing ID4	01	00000001
45	2D	Standard timing ID4	01	00000001
46	2E	Standard timing ID5	01	00000001
47	2F	Standard timing ID5	01	00000001



Product Specification

17

AU OPTRONICS CORPORATION

B150XG07-V3

48	30	Standard timing ID6	01	00000001
49	31	Standard timing ID6	01	00000001
50	32	Standard timing ID7	01	00000001
51	33	Standard timing ID7	01	00000001
52	34	Standard timing ID8	01	00000001
53	35	Standard timing ID8	01	00000001
54	36	Pixel Clock/10,000 (LSB) 6500=1964h	64	01100100
55	37	Pixel Clock/10,000 (MSB)	19	00011001
56	38	Horizontal Active 1024=400h "00"	00	00000000
57	39	Horizontal Blanking (Thbp) 320=140h "40"	40	01000000
58	3A	Horizontal Active/Horizontal Blanking (Thbp) "41h"	41	01000001
59	3B	Vertical Active 768=300h "00"	00	00000000
60	3C	Vertical Blanking 38 (Tvbp)=26h "26"	26	00100110
61	3D	Vertical active/Vertical blanking (Tvbp) "30"	30	00110000
62	3E	Horizontal Sync, Offset (Thfp) 24=18h "18"	18	00011000
63	3F	Horizontal Sync, Pulse Width 136=88h "88"	88	10001000
64	40	Vertical Sync, Offset (Tvfp)/Sync Width	36	00110110
65	41	Horizontal Vertical Sync Offset/Width upper 2 bits	00	00000000
66	42	Horizontal Image Size 304mm=130h "30"	30	00110000
67	43	Vertical Image Size 228mm=E4h "E4"	E4	11100100
68	44	Horizontal Image Size / Vertical Image Size	10	00010000
69	45	Horizontal Border	00	00000000
70	46	Vertical Border	00	00000000
71	47	Non-interlaced, Normal, no stereo, Separate sync, H/V pol Negatives, DE only note: LSB is set to "1" if panel is DE-timing only. H/V can be ignored.	18	00011000
72	48	Detailed timing descriptor#2	00	00000000
73	49	Flag	00	00000000
74	4A	Reserved	00	00000000
75	4B	Dummy Descriptor	0F	00001111
76	4C	Flag	00	00000000
77	4D	Value=HSPW(Min) (pixel clks) 2=2h	02	00000010
78	4E	Value=HSPW(Max) (pixel clks) 250=FAh	FA	11111010
79	4F	Value=Thbp(Min) (pixel clks) DE mode	00	00000000
80	50	Value=Thbp(Max) (pixel clks) DE mode	00	00000000
81	51	Value=VSPW(Min) (line pulses) 1=1h	01	00000001
82	52	Value=VSPW(Max) (line pulses) 36=24h	24	00100100
83	53	Value=Tvbp(Min) (line pulses) 6=6h	06	00000110
84	54	Value=Tvbp(Max) (line pulses) 34=22h	22	00100010
85	55	Thp(Min)=Value*2+HA (pixel clks) 1032=408h =08h	08	00001000
86	56	Thp(Max)=Value*2+HA (pixel clks) 2047=7FFh=FFh	FF	11111111
87	57	Tvp(Min)=Value*2+VA (line pulses) 803=323h=23h	23	00100011
88	58	Tvp(Max)=Value*2+VA (line pulses) 2047=7FFh=FFh	FF	11111111
89	59	Module "A" Revision= 0	00	00000000
90	5A	Flag	00	00000000
91	5B	Flag	00	00000000
92	5C	Flag	00	00000000
93	5D	Dummy Descriptor	FE	11111110
94	5E	Flag	00	00000000
95	5F	Dell PN Character T	54	01010100
96	60	Dell PN Character 7	37	00110111
97	61	Dell PN Character 9	39	00111001
98	62	Dell PN Character 7	37	00110111
99	63	Dell PN Character 6	36	00110110
100	64	LCD Supplier EEDID Reversion # 00	00	00000000
101	65	Manufacturer PN	00	00000000
102	66	Manufacturer PN	00	00000000



Product Specification

18

AU OPTRONICS CORPORATION

B150XG07 V3

103	67	Manufacturer PN	00	00000000
104	68	Manufacturer PN	00	00000000
105	69	Manufacturer PN	00	00000000
106	6A	Manufacturer PN	00	00000000
107	6B	Manufacturer P/N (if <13 char, then terminate with ASCII code 0Ah, set remaining char =20h)	00	00000000
108	6C	Flag	00	00000000
109	6D	Flag	00	00000000
110	6E	Flag	00	00000000
111	6F	Data Type Tag ASCII String	FE	11111110
112	70	Flag	00	00000000
113	71	SMBUS Value=10nits	F0	11110000
114	72	SMBUS Value=17nits	E0	11100000
115	73	SMBUS Value=24nits	D8	11011000
116	74	SMBUS Value=30nits	D0	11010000
117	75	SMBUS Value=60nits	B0	10110000
118	76	SMBUS Value=110nits	78	01111000
119	77	SMBUS Value=150nits	50	01010000
120	78	SMBUS Value=180 nits	30	00110000
121	79	Number of LVDS receiver chips	01	00000001
122	7A	Panel type- BIST Enable	01	00000001
123	7B	(If<13 char, then terminate with ASCII code 0Ah, set remaining char=20h)	0A	00001010
124	7C	(If<13 char, then terminate with ASCII code 0Ah, set remaining char=20h)	20	00100000
125	7D	(If<13 char, then terminate with ASCII code 0Ah, set remaining char=20h)	20	00100000
126	7E	Extension flag	00	00000000
127	7F	Checksum	72	01110010



Product Specification

AU OPTRONICS CORPORATION

B150XG07 V3

10. Optical Characteristics

Ta=25°C, Vcc=+3.3V

Parameter		Symbol	Condition	Min.	Typ.	Max.	Unit	Remark
Viewing Angle Range	Horizontal	$\theta 21, \theta 22$	CR>10	45	—	—	Deg.	[Note1,4]
	Vertical	$\theta 11$		10	—	—	Deg.	
		$\theta 12$		30	—	—	Deg.	
Contrast ratio		C R n	$\theta = 0^\circ$	350	—	—		[Note2,4]
Response Time	Rise	τr	$\theta = 0^\circ$	—	10	—	ms	[Note3,4]
	Decay	τd		—	15	—	ms	
Chromaticity of White		W_x W_y		0.293 0.309	0.313 0.329	0.333 0.349		[Note4]
Chromaticity of Red		R_x R_y		0.560 0.320	0.580 0.340	0.600 0.360		
Chromaticity of Green		G_x G_y		0.290 0.530	0.310 0.550	0.330 0.570		
Chromaticity of Blue		B_x B_y		0.135 0.135	0.155 0.155	0.175 0.175		
Luminance of white		Y_{L2}	5 Points	150	180	—	Cd/m ²	$I_L = 6.0\text{mA}_{rms}$ $F_L = 55\text{kHz}$
Color Gamut		Δ		45%				NTSC
White Uniformity		δ_w	5 Points 13 Points	—	—	20% 35%		[Note4]

The optical characteristics shall be measured in a dark room or equivalent state with the method shown in Fig.3.



Product Specification

AU OPTRONICS CORPORATION

B150XG07 V3

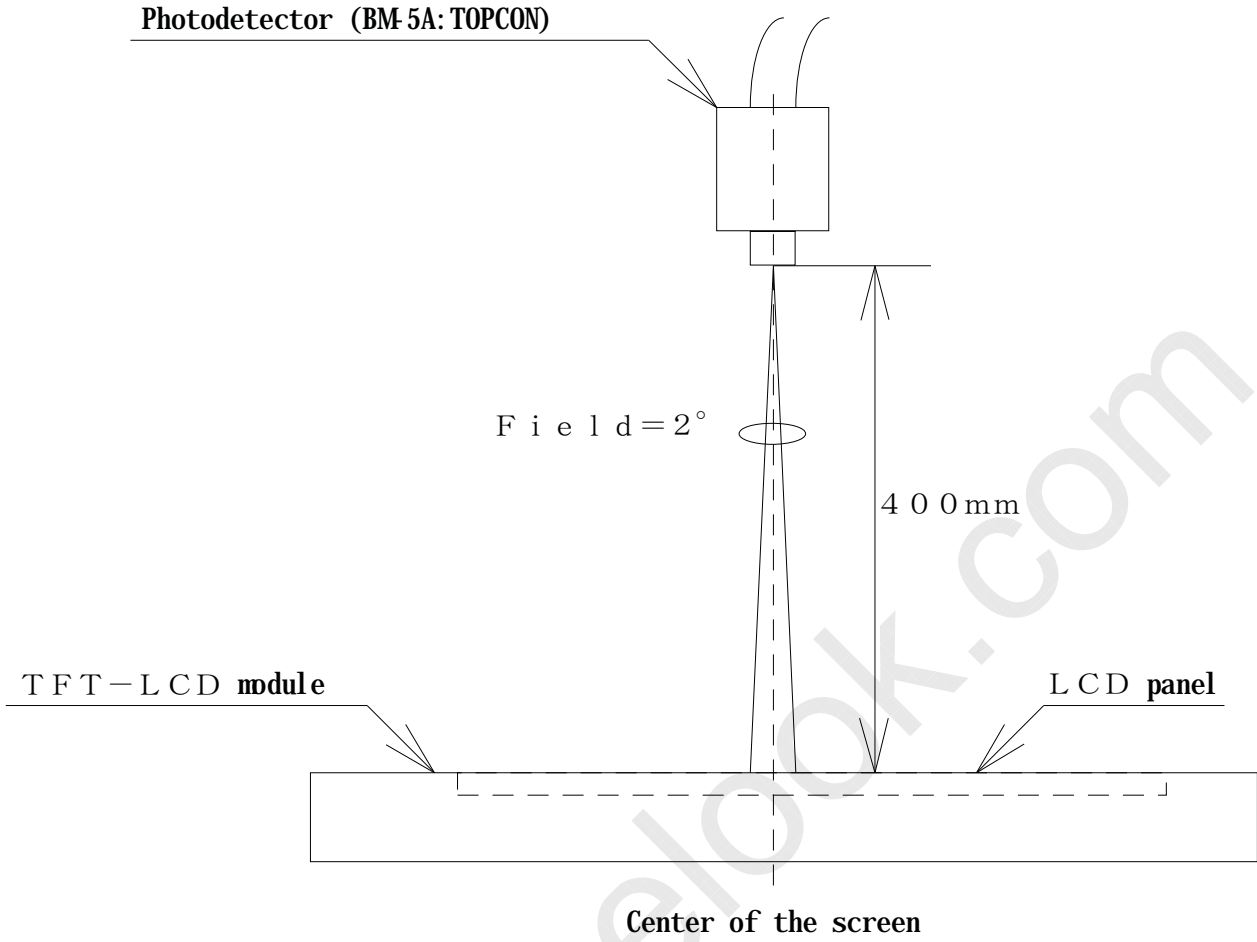

Fig. 3 Optical characteristics measurement method



Product Specification

AU OPTRONICS CORPORATION

B150XG07 V3

[Note1] Definitions of viewing angle range:

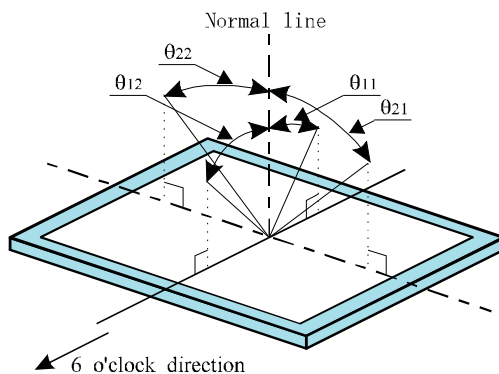

[Note2] Definition of contrast ratio:

The contrast ratio is defined as the following.

Contrast Ratio (CR)=

$$\frac{\text{Luminance (brightness) with all pixels white}}{\text{Luminance (brightness) with all pixels black}}$$

[Note3] Definition of response time:

The response time is defined as the following figure and shall be measured by switching the input signal for "black" and "white" .

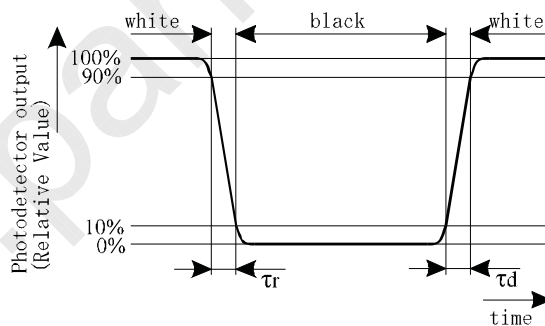

[Note4] Definition of white uniformity:

$$\delta_w = \frac{\text{Maximum Lum (5p/13p)} - \text{Minimum Lum (5p/13p)}}{\text{Maximum Lum (5/13p)}}$$

(5 Points A,B,C,D,E

13 Points A,B,C,D,E,F,G,H,I,J,K,L,M)

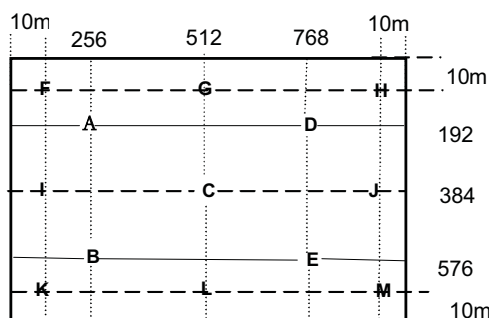

**11. Display Quality**

The display quality of the color TFT-LCD module shall be in compliance with the Incoming Inspection Standard.

12 · Handling Precautions

- a) Be sure to turn off the power supply when inserting or disconnecting the cable.
- b) Be sure to design the cabinet so that the module can be installed without any extra stress such as warp or twist.
- c) Since the front polarizer is easily damaged, pay attention not to scratch it.
- d) Wipe off water drop immediately. Long contact with water may cause discoloration or spots.
- e) When the panel surface is soiled, wipe it with absorbent cotton or other soft cloth.
- f) Since the panel is made of glass, it may break or crack if dropped or bumped on hard surface. Handle with care.
- g) Since CMOS LSI is used in this module, take care of static electricity and injure the human earth when handling.
- h) Observe all other precautionary requirements in handling components.
- i) This module has its circuitry PCBs on the rear side and should be handled carefully in order not to be stressed.
- j) Laminated film is attached to the module surface to prevent it from being scratched. Peel the film off slowly just before the use with strict attention to electrostatic charges. Ionized air shall be blown over during the action. Blow off the 'dust' on the polarizer by using an ionized nitrogen gun, etc.
- K) Mounting screw hole can stand torque 1.3~1.5 Kgf-cm.



Product Specification

23

AU OPTRONICS CORPORATION

B150XG07 V3

13 · Reliability test items

No.	Test item	Conditions
1	High temperature storage test	Ta = 60°C 250h
2	Low temperature storage test	Ta = -25°C 250h
3	High temperature & high humidity operation test	Ta = 40°C ; 90 %RH 240h ; (as remark 3) (No condensation)
4	High temperature operation test	Ta = 50°C 250h (The panel temp. must be less than 60 °C)
5	Low temperature operation test	Ta = 0°C 250h
6	Vibration test (non- operating)	Frequency: 10~500Hz, 1.5G, Test period : 3 hours (1 hour for each direction of X,Y,Z)
7	Shock test (non- operating)	Max. gravity : 220G Pulse width: 2 ms, Half sine wave Direction : ±X,±Y,±Z once for each direction.

Remark:

- (1) A failure is defined as the appearance of pixel failed on any color layer or the appearance of horizontal or vertical lines, bars etc.
- (2) Low temperature storage “ Panel must return to operating temperature range prior to activation.”
- (3) Hi temperature / Humidity test
Max. wet-bulb temperature is less than 39°C ; At glass temperature high than 40 °C.
Temperature and relative humidity range is shown in the figure below.

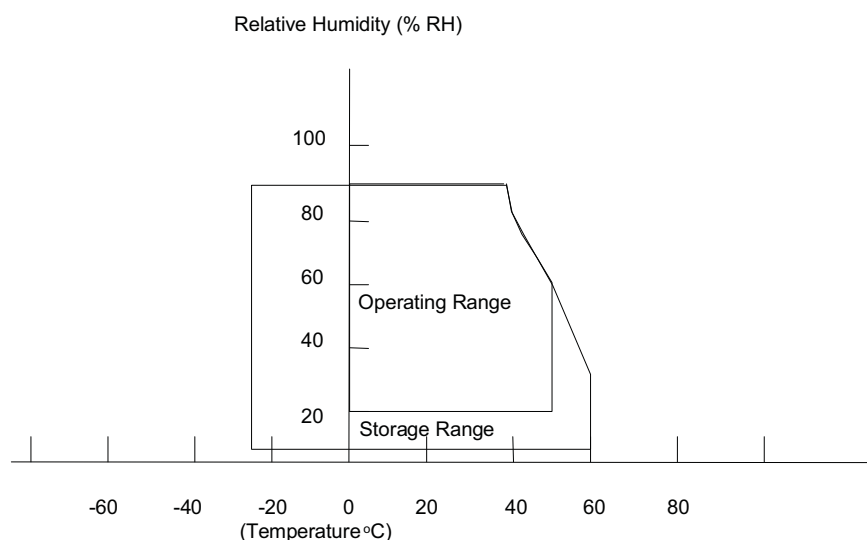



Product Specification

24

AU OPTRONICS CORPORATION

B150XG07 V3

14. Others

1) Lot No. Label:

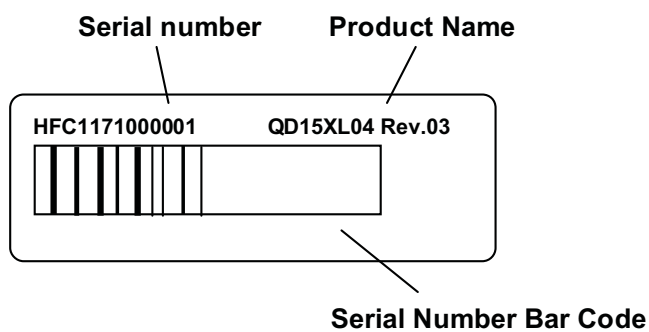

- 2) Adjusting volume has been set optimally before shipment, so do not change any adjusted value. If adjusted value is changed, the specification may not be satisfied.
- 3) Disassembling the module can cause permanent damage and should be strictly avoided.
- 4) Please be careful since image retention may occur when a fixed pattern is displayed for a long time.



Product Specification

AU OPTRONICS CORPORATION

B150XG07 V3

15. Mechanical Outline dimension

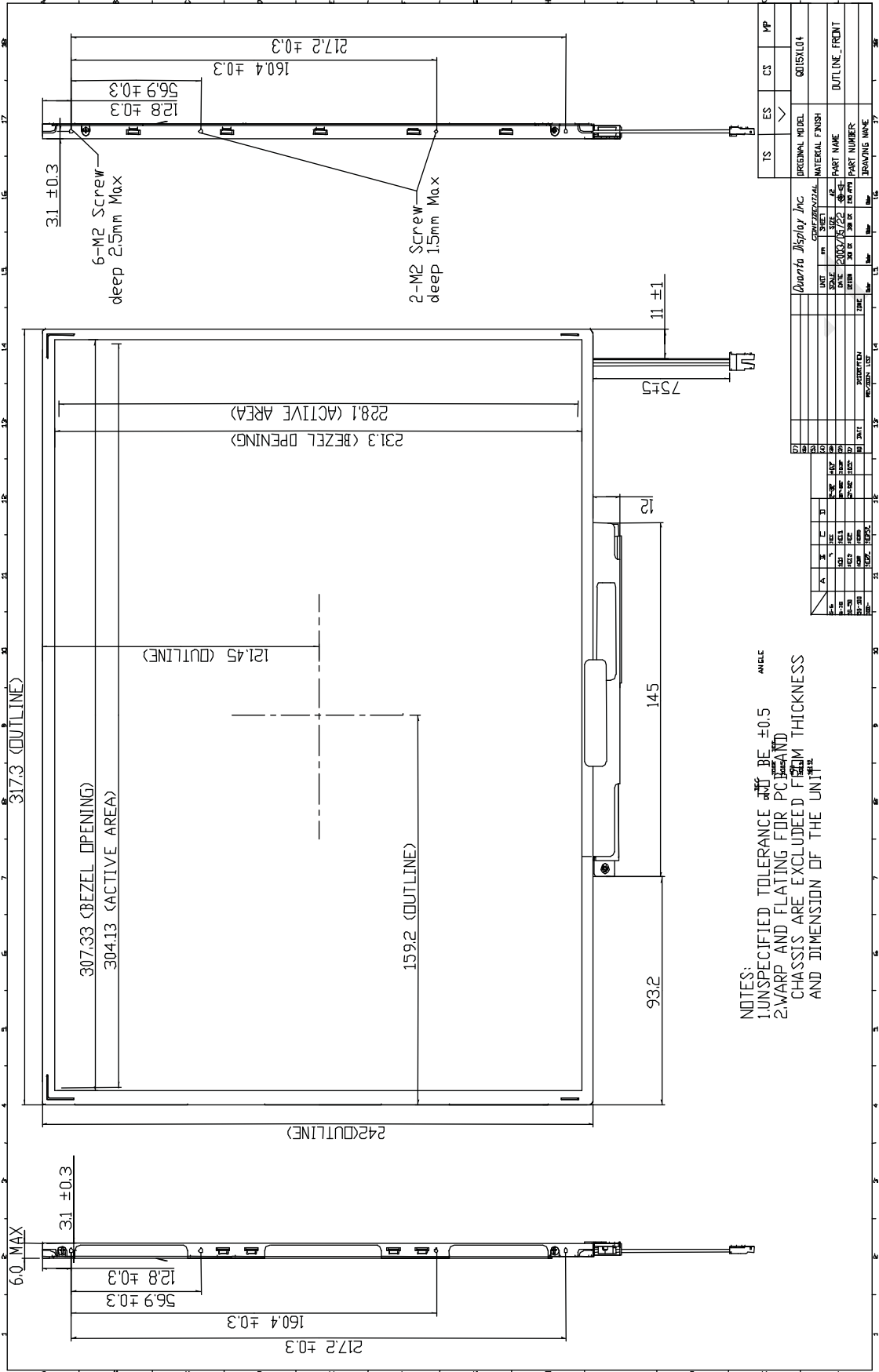

NOTES:

- UNSPECIFIED TOLERANCE SHALL BE ±0.5 ANGLE
- WARP AND FLATING FOR PC BOARD AND CHASSIS ARE EXCLUDED FROM THICKNESS AND DIMENSION OF THE UNIT

Product Specification

AU OPTRONICS CORPORATION

P150Y607 V2

26

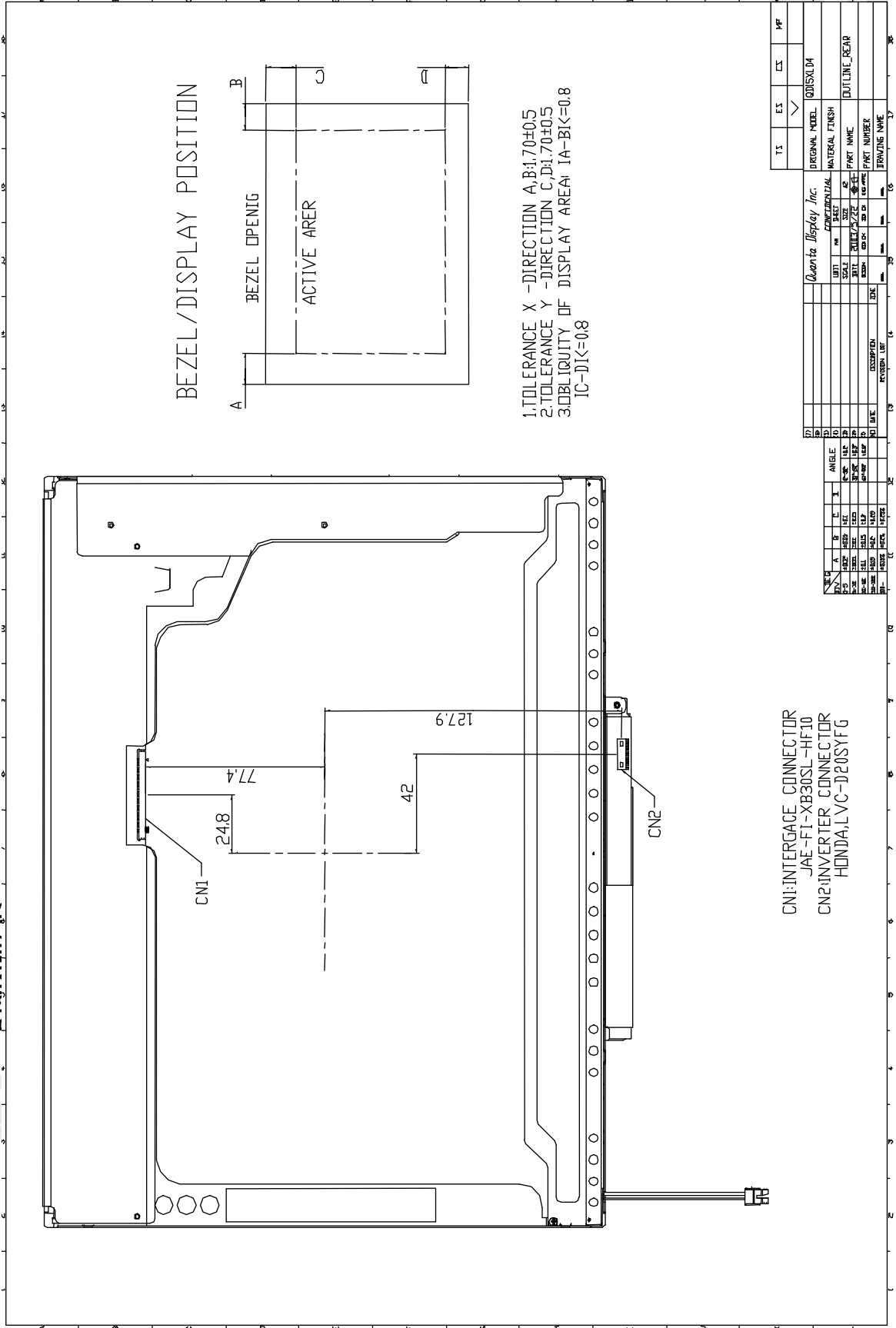



Product Specification

AU OPTRONICS CORPORATION

B150XG07 V3

www.panelook.com