



**Document Version: 6**  
**Date: 2004/10/03**

## Product Functional Specification

15.4 inch WXGA Color TFT LCD Module  
Model Name : B154EW01 V1

Preliminary Specification  
 Final Specification

Note: This Specification is subject to change without notice.

## I. Contents

- 1.0 Handling Precautions
- 2.0 General Description
  - 2.1 Characteristics
  - 2.2 Functional Block Diagram
- 3.0 Absolute Maximum Ratings
- 4.0 Optical Characteristics
- 5.0 Signal Interface
  - 5.1 Connectors
  - 5.2 Signal Pin
  - 5.3 Signal Description
  - 5.4 Signal Electrical Characteristics
  - 5.5 Signal for Lamp Connector
- 6.0 Pixel Format Image
- 7.0 Parameter Guide Line for CFL Inverter
- 8.0 Interface Timings
  - 8.1 Timing Characteristics
  - 8.2 Timing Definition
- 9.0 Power Consumption
- 10.0 Power ON/OFF Sequence
- 11.0 Reliability Test Condition
- 12.0 Mechanical Characteristics
- 13.0 Shipping Label Format
- 14.0 Carton package
- 15.0 Shipping package of palletizing sequence
- 16.0 Appendix: EDID descriptipn

## II Record of Revision

Version and Date	Page	Old description	New Description	Remark
0.1. 2003/12/19	All	First Edition for Customer	All	
0.2. 2004/01/08	5	Weight: 580g	Weight: 585g	

(C) Copyright AU Optronics, Inc.  
August, 2003 All Rights Reserved.

B154EW01 V1 Ver.6

2/34

No Reproduction and Redistribution Allowed.

	5		Add surface treatment	
	18	CCFL Frequency: 55KHz-65KHz	CCFL Frequency: 50KHz-70KHz	
	23		Mechanical drawing updated	
0.3 2004/03/15	25		Add description of screw hole length and torque	
	27		Add carton package description	
0.4 2004/04/28	5	Physical Size: 344x 222.0 x 6.5 max.	Physical Size: 344x 222.0 x 6.8 max	
	21	IDD current: 600mA typ.	IDD current: 500mA typ.	
	21		Add IDD current: 600mA max.	
	25		Mechanical drawing updated	
0.5 2004/06/28	31		Add EDID description	

## 1.0 Handling Precautions

- 1) Since front polarizer is easily damaged, pay attention not to scratch it.
- 2) Be sure to turn off power supply when inserting or disconnecting from input connector.
- 3) Wipe off water drop immediately. Long contact with water may cause discoloration or spots.
- 4) When the panel surface is soiled, wipe it with absorbent cotton or other soft cloth.
- 5) Since the panel is made of glass, it may break or crack if dropped or bumped on hard surface.
- 6) Since CMOS LSI is used in this module, take care of static electricity and insure human earth when handling.
- 7) Do not open nor modify the Module Assembly.
- 8) Do not press the reflector sheet at the back of the module to any directions.
- 9) In case if a Module has to be put back into the packing container slot after once it was taken out from the container, do not press the center of the CCFL Reflector edge. Instead, press at the far ends of the CFL Reflector edge softly. Otherwise the TFT Module may be damaged.
- 10) At the insertion or removal of the Signal Interface Connector, be sure not to rotate nor tilt the Interface Connector of the TFT Module.
- 11) After installation of the TFT Module into an enclosure (Notebook PC Bezel, for example), do not twist nor bend the TFT Module even momentary. At designing the enclosure, it should be taken into consideration that no bending/twisting forces are applied to the TFT Module from outside. Otherwise the TFT Module may be damaged.

- 12) Cold cathode fluorescent lamp in LCD contains a small amount of mercury. Please follow local ordinances or regulations for disposal.
- 13) Small amount of materials having no flammability grade is used in the LCD module. The LCD module should be supplied by power complied with requirements of Limited Power Source(2.11, IEC60950 or UL1950), or be applied exemption.
- 14) The LCD module is designed so that the CFL in it is supplied by Limited Current Circuit(2.4, IEC60950 or UL1950). Do not connect the CFL in Hazardous Voltage Circuit.

## 2.0 General Description

B154EW01 V1 is a Color Active Matrix Liquid Crystal Display composed of a TFT LCD panel, a driver circuit, and backlight system. The screen format is intended to support the WXGA (1280(H) x 800(V)) screen and 262k colors (RGB 6-bits data driver). All input signals are LVDS interface compatible. Inverter card of backlight is not included.

B154EW01 V1 is designed for a display unit of notebook style personal computer and industrial machine.

## 2.1 Display Characteristics

The following items are characteristics summary on the table under 25 °C condition:

ITEMS	Unit	SPECIFICATIONS
Screen Diagonal	[mm]	391mm
Active Area	[mm]	331.2 X 207.0
Pixels H x V		1280x3(RGB) x 800
Pixel Pitch	[mm]	0.2588X0.2588
Pixel Arrangement		R.G.B. Vertical Stripe
Display Mode		Normally White
Typical White Luminance (ICFL=6.0mA)	[cd/m <sup>2</sup> ]	195 min (5 point average) 220 Typ. (5 point average)
Luminance Uniformity		1.25 max. (5 pts) 1.50 max. (13pts)
Contrast Ratio		300 min 400 typ
Optical Rise Time/Fall Time	[msec]	18/7
Nominal Input Voltage VDD	[Volt]	+3.3 Typ.
Typical Power Consumption (VDD line + VCFL line)	[Watt]	6.5W max
Weight	[Grams]	585g typ.
Physical Size	[mm]	344x 222.0 x 6.8 max.
Electrical Interface		1 channel LVDS
Surface Treatment		Glare, Harness 2H, Haze 41.7%, Reflectance 2.5%
Support Color		Native 262K colors ( RGB 6-bit data driver )
Temperature Range Operating Storage (Non-Operating)	[°C] [°C]	0 to +50 -20 to +60

## 2.2 Functional Block Diagram

The following diagram shows the functional block of the 15.4 inches Color TFT/LCD Module:

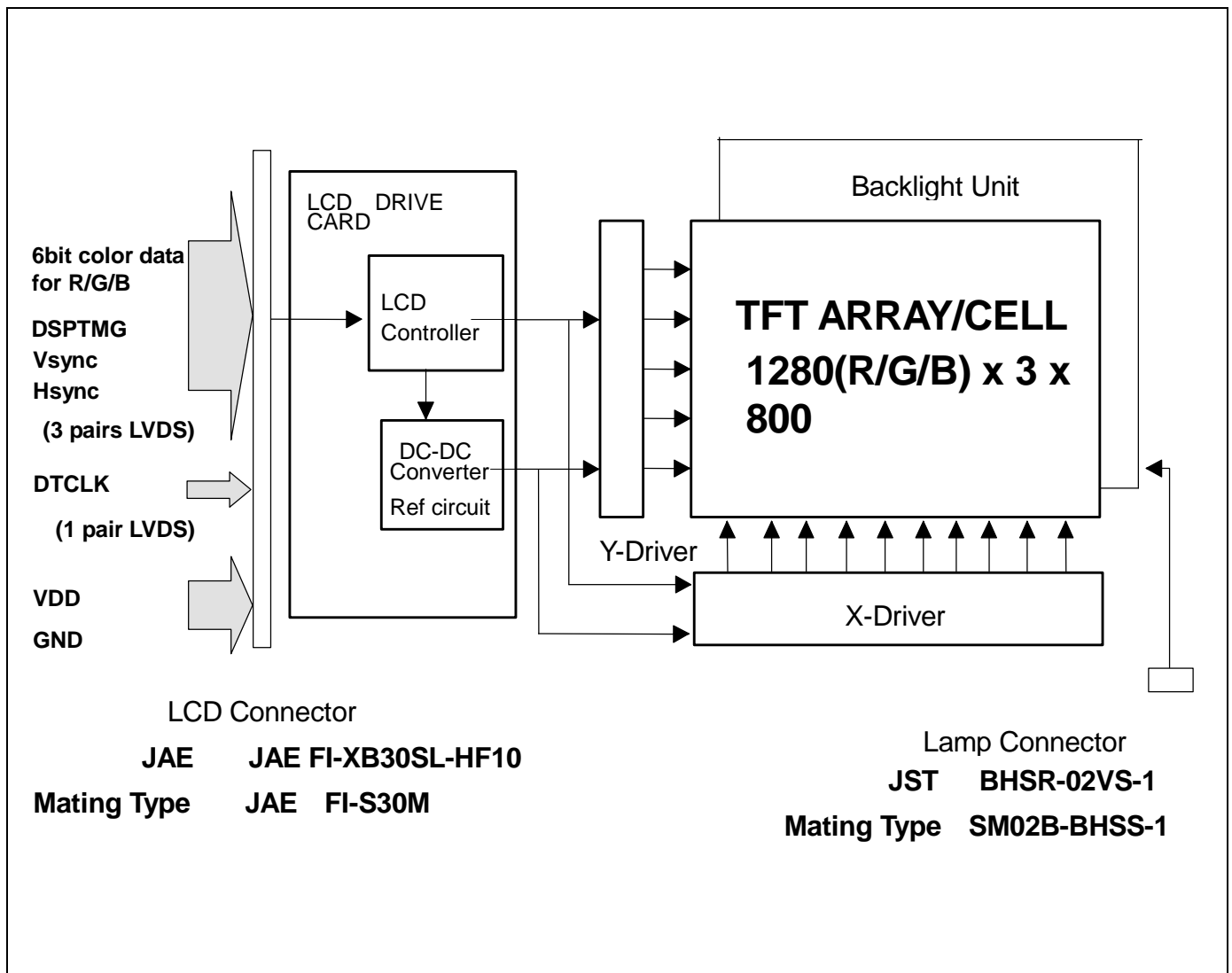

### 3.0 Absolute Maximum Ratings

Absolute maximum ratings of the module is as following:



Item	Symbol	Min	Max	Unit	Conditions
Logic/LCD Drive Voltage	VDD	-0.3	+4.0	[Volt]	
Input Voltage of Signal	Vin	-0.3	VDD+0.3	[Volt]	
CCFL Current	ICFL	-	6.5	[mA] rms	
CCFL Ignition Voltage	Vs	-	1000	Vrms	
Operating Temperature	TOP	0	+50	[°C]	Note 1
Operating Humidity	HOP	8	95	[%RH]	Note 1
Storage Temperature	TST	-20	+60	[°C]	Note 1
Storage Humidity	HST	5	95	[%RH]	Note 1
Vibration			1.5 10-500 (random)	G Hz	2hrs/axis, X,Y,Z
Shock(Non-operating)			220 , 2	G ms	Half sine wave

Note 1 : Maximum Wet-Bulb should be 39°C and No condensation.

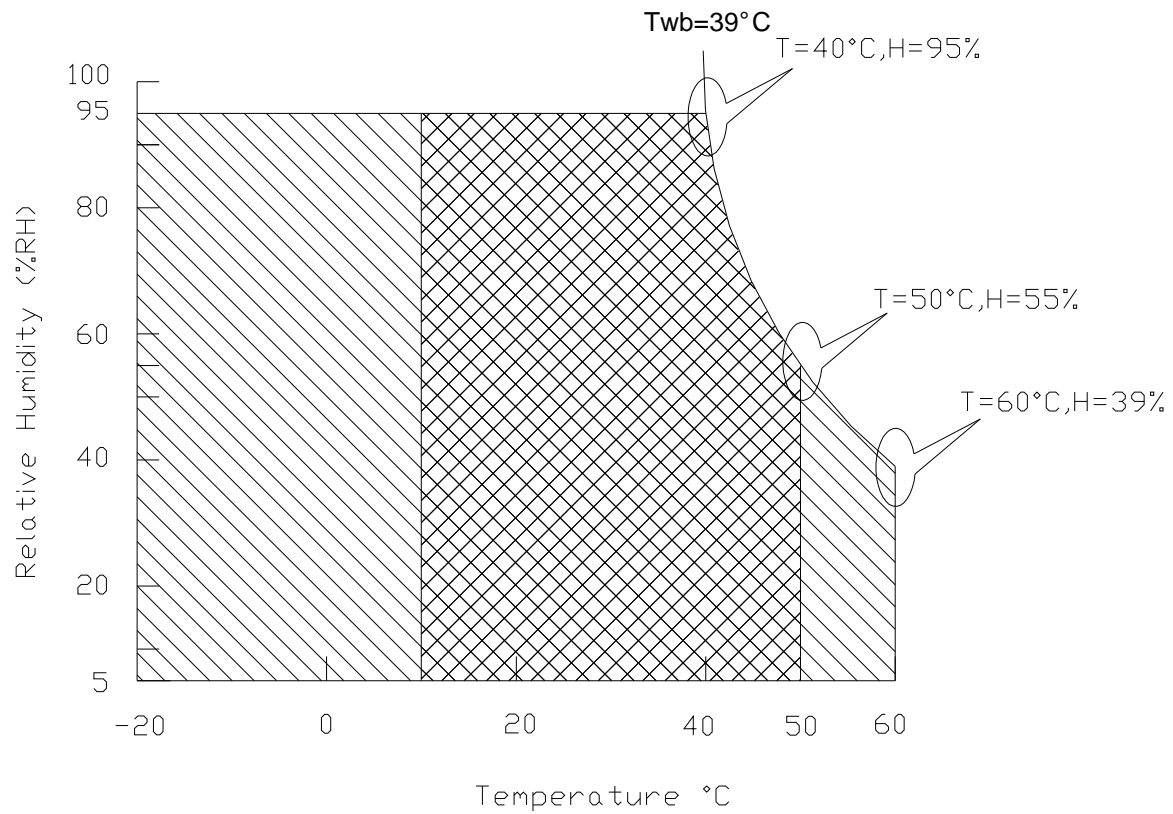

### 3.1 Wet-Bulb temperature chart



Operating Range   
 Storage Range  + 

## 4.0 Optical Characteristics

The optical characteristics are measured under stable conditions as follows under 25 °C condition:

Item		Conditions	Typ.	Note
Viewing Angle	[degree]	Horizontal (Right) K = 10 (Left)	70 70	Note 4, Note 6
K: Contrast Ratio	[degree]	Vertical (Upper) K = 10 (Lower)	60 60	Note 4, Note 6
Contrast ratio			400	Note 4
Luminance Uniformity			1.25 max. (5 pts) 1.50 max. (13pts)	Note 1, Note 2, Note 3, Note 4
Cross talk	%		4% max	Note 5
Response Time (Room Temp.)	[msec] [msec]	Rising Falling	18 7	Note 7 Note 7
Color Chromaticity Coordinates (CIE)		Red x Red y Green x Green y Blue x Blue y White x White y	0.600+/-0.03 0.350+/-0.03 0.310+/-0.03 0.550+/-0.03 0.150+/-0.03 0.115+/-0.03 0.313+/-0.03 0.329+/-0.03	Note 4
White Luminance (CCFL 6.0 mA)	[cd/m <sup>2</sup> ]		195min(5 points average) 220 (5 points average)	Note 1, Note 2, Note 4

Note 1: 5 points position (Display area : 331.2mm x 207.0mm)

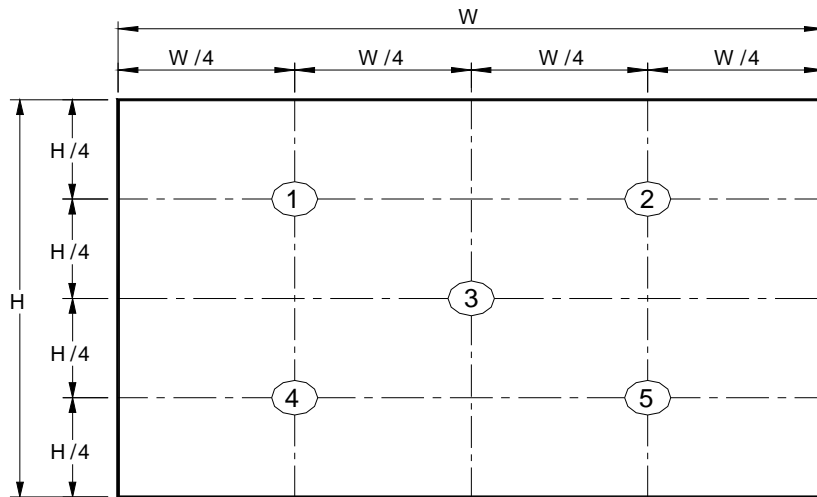

Note 2: 13 points position

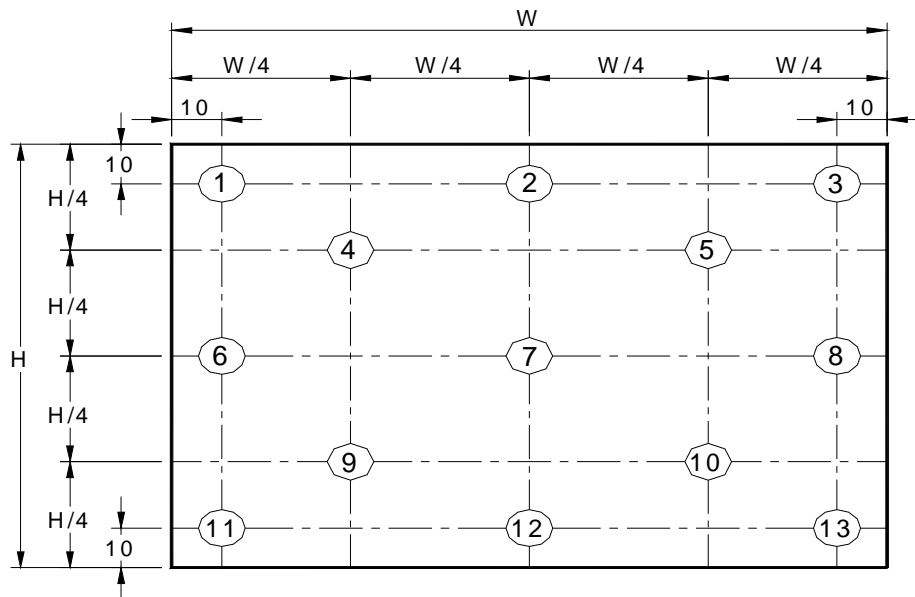

Note 3: The luminance uniformity of 5 and 13 points is defined by dividing the maximum luminance values by the minimum test point luminance

$$\delta_{w5} = \frac{\text{Maximum Brightness of five points}}{\text{Minimum Brightness of five points}}$$

$$\delta_{w13} = \frac{\text{Maximum Brightness of thirteen points}}{\text{Minimum Brightness of thirteen points}}$$

Note 4: Measurement method

The LCD module should be stabilized at given temperature for 30 minutes to avoid abrupt temperature change during measuring. In order to stabilize the luminance, the measurement should be executed after lighting Backlight for 30 minutes in a stable, windless and dark room.

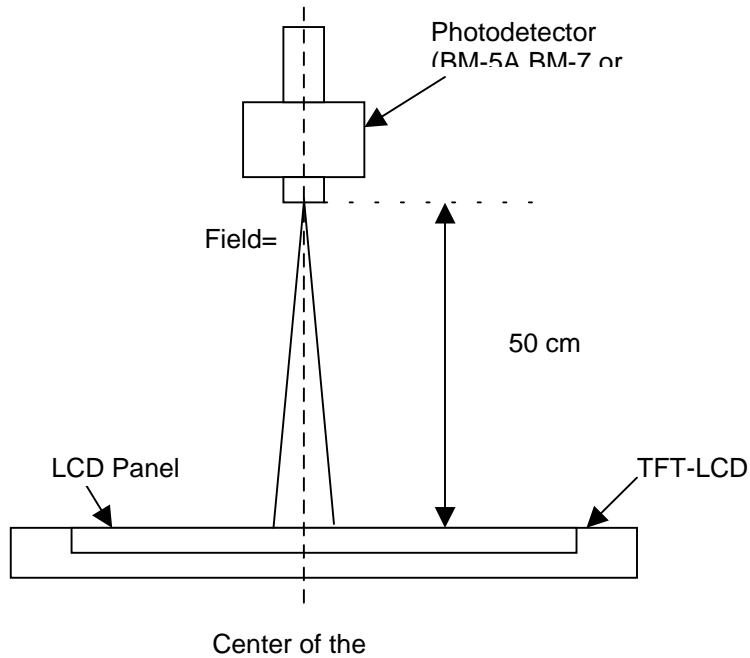

Note 5 : Definition of Cross Talk (CT)

$$CT = |Y_B - Y_A| / Y_A \times 100 (\%)$$

Where

$Y_A$  = Luminance of measured location without gray level 0 pattern (cd/m<sup>2</sup>)

$Y_B$  = Luminance of measured location with gray level 0 pattern (cd/m<sup>2</sup>)

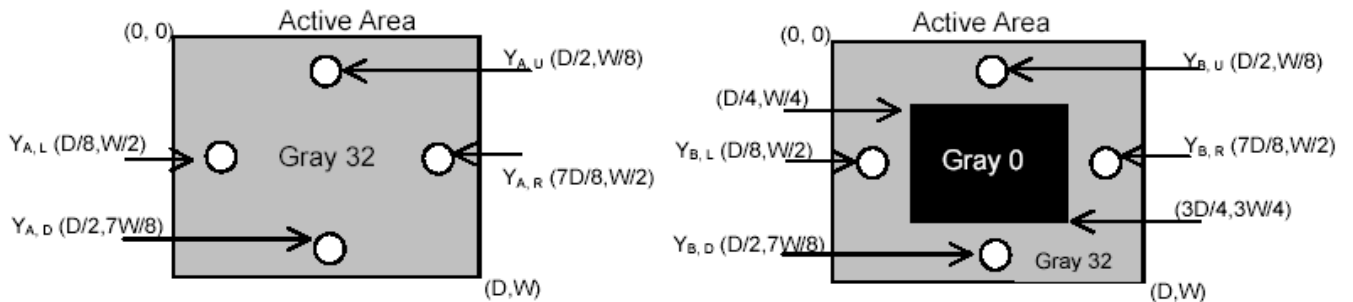

Note 6: Definition of response time:

The output signals of BM-7 or equivalent are measured when the input signals are changed from "Black" to "White" (falling time) and from "White" to "Black" (rising time), respectively. The response time interval between the 10% and 90% of amplitudes. Refer to figure as below.

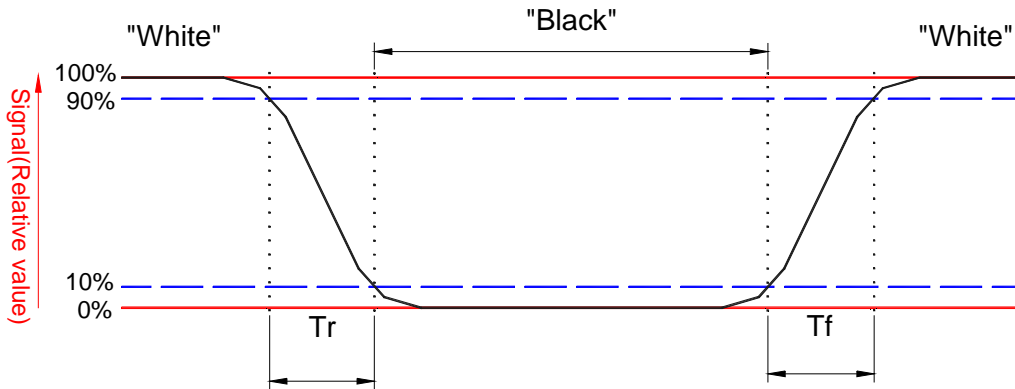

Note 7. Definition of viewing angle

Viewing angle is the measurement of contrast ratio  $\geq 10$ , at the screen center, over a  $180^\circ$  horizontal and  $180^\circ$  vertical range (off-normal viewing angles). The  $180^\circ$  viewing angle range is broken down as follows;  $90^\circ$  ( $\theta$ ) horizontal left and right and  $90^\circ$  ( $\Phi$ ) vertical, high (up) and low (down). The measurement direction is typically perpendicular to the display surface with the screen rotated about its center to develop the desired measurement viewing angle.

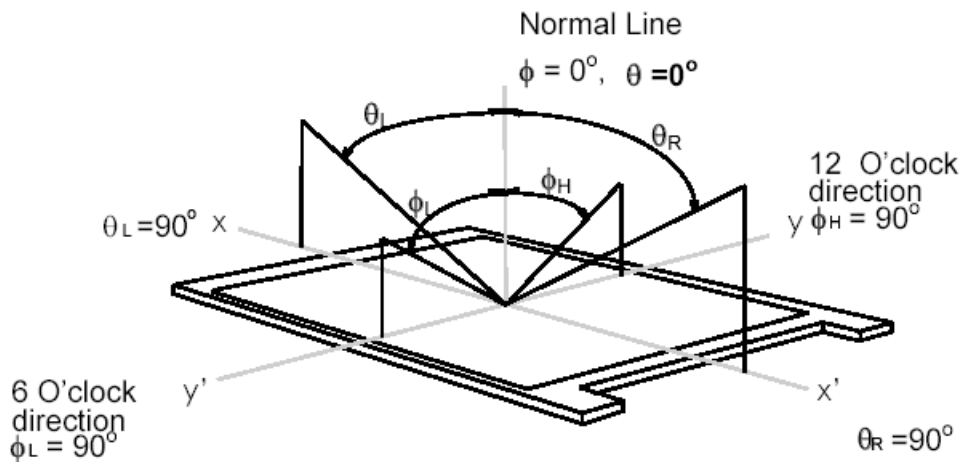

## 5.0 Signal Interface

(C) Copyright AU Optronics, Inc.  
August, 2003 All Rights Reserved.

B154EW01 V1 Ver.6

## 5.1 Connectors

Physical interface is described as for the connector on module.

These connectors are capable of accommodating the following signals and will be following components.

Connector Name / Designation	For Signal Connector
Manufacturer	JAE or compatible
Type / Part Number	FI-XB30SL-HF10 or compatible
Mating Housing/Part Number	FI-X30M, FI-X30C or FI-X30H
Mating Contact/Part Number	FI-C3-A1

Connector Name / Designation	For Lamp Connector
Manufacturer	JST
Type / Part Number	BHSR-02VS-1
Mating Type / Part Number	SM02B-BHSS-1-TB

## 5.2 Signal Pin

Pin#	Signal Name	Pin#	Signal Name
1	GND	2	VDD
3	VDD	4	VEDID
5	NC	6	CLKEDID
7	DATAEDID	8	RxIN0-
9	RxIN0+	10	GND
11	RxIN1-	12	RxIN1+
13	GND	14	RxIN2-
15	RxIN2+	16	GND
17	RxCLKIN-	18	RxCLKIN+
19	GND	20	GND
21	NC	22	NC
23	NC	24	NC
25	NC	26	NC
27	NC	28	NC
29	NC	30	NC

### 5.3 Signal Description

The module is use a LVDS receiver. LVDS is a differential signal technology for LCD interface and high speed data transfer device. Transmitter shall be SN75LVDS86 (negative edge sampling) or compatible.

Signal Name	Description
RxIN0-, RxIN0+	LVDS differential data input(Red0-Red5, Green0)
RxIN1-, RxIN1+	LVDS differential data input(Green1-Green5, Blue0-Blue1)
RxIN2-, RxIN2+	LVDS differential data input(Blue2-Blue5, Hsync, Vsync, DSPTMG)
RxCLKIN-, RxCLKIN0+	LVDS differential clock input
VDD	+3.3V Power Supply
GND	Ground

Note: Input signals shall be low or Hi-Z state when VDD is off.  
Internal circuit of LVDS inputs are as following.

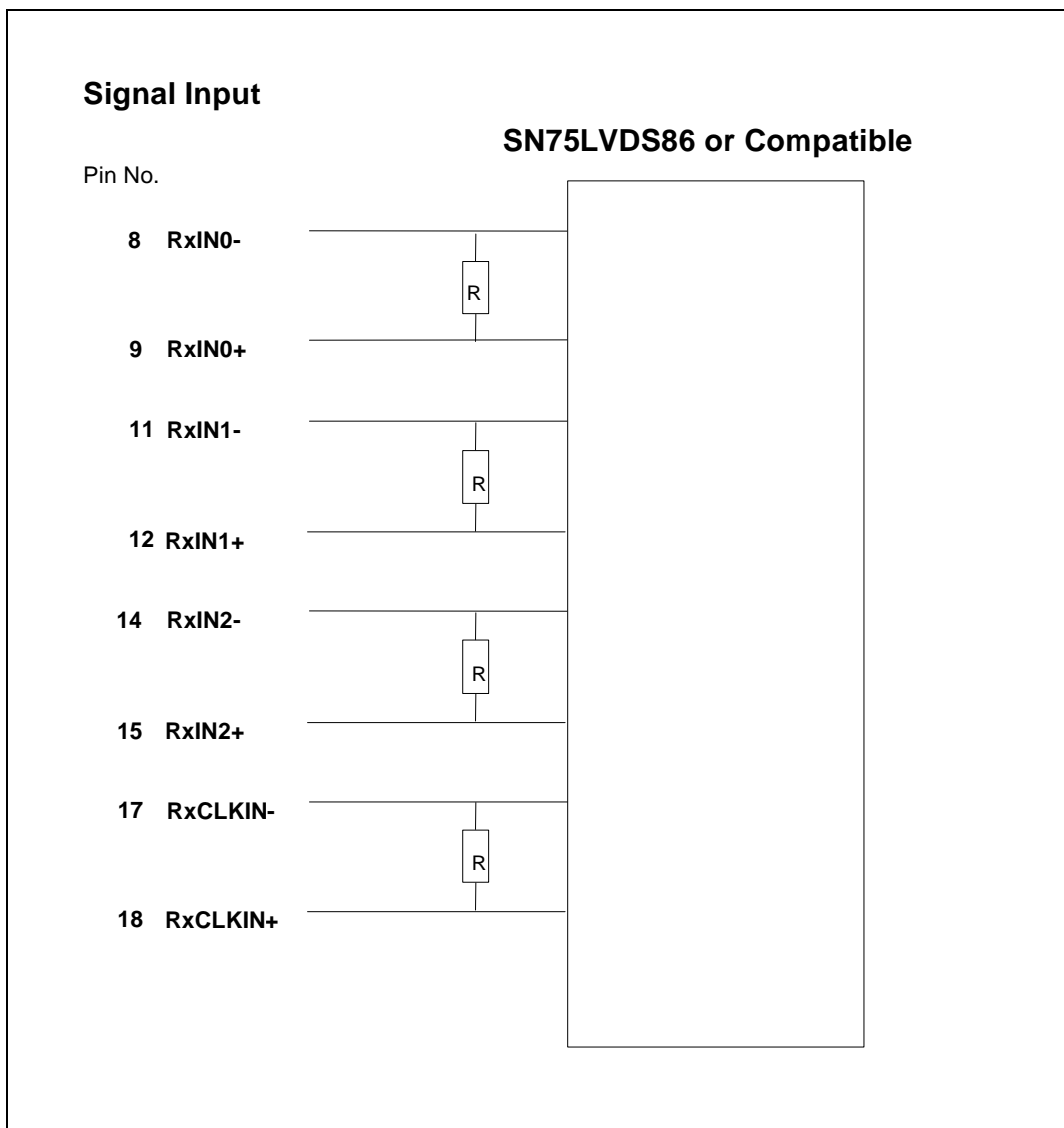

The module uses a 100ohm resistor between positive and negative data lines of each receiver input

Signal Name	Description	
RED5	Red Data 5 (MSB)	Red-pixel Data Each red pixel's brightness data consists of these 6 bits pixel data.
RED4	Red Data 4	
RED3	Red Data 3	
RED2	Red Data 2	
RED1	Red Data 1	
RED0	Red Data 0 (LSB)	
	Red-pixel Data	
GREEN 5	Green Data 5 (MSB)	Green-pixel Data



GREEN 4 GREEN 3 GREEN 2 GREEN 1 GREEN 0	Green Data 4 Green Data 3 Green Data 2 Green Data 1 Green Data 0 (LSB)  Green-pixel Data	Each green pixel's brightness data consists of these 6 bits pixel data.
BLUE 5 BLUE 4 BLUE 3 BLUE 2 BLUE 1 BLUE 0	Blue Data 5 (MSB) Blue Data 4 Blue Data 3 Blue Data 2 Blue Data 1 Blue Data 0 (LSB)  Blue-pixel Data	Blue-pixel Data Each blue pixel's brightness data consists of these 6 bits pixel data.
DTCLK	Data Clock	The typical frequency is 68.9 MHz. The signal is used to strobe the pixel data and DSPTMG signals. All pixel data shall be valid at the falling edge when the DSPTMG signal is high.
DSPTMG	Display Timing	This signal is strobed at the falling edge of -DTCLK. When the signal is high, the pixel data shall be valid to be displayed.
VSYNC	Vertical Sync	The signal is synchronized to -DTCLK .
HSYNC	Horizontal Sync	The signal is synchronized to -DTCLK .

Note: Output signals from any system shall be low or Hi-Z state when VDD is off.

#### 5.4 Signal Electrical Characteristics

Input signals shall be low or Hi-Z state when VDD is off.

It is recommended to refer the specifications of SN75LVDS86DGG(Texas Instruments) in detail.

Signal electrical characteristics are as follows;

Parameter	Condition	Min	Max	Unit
Vth	Differential Input High Voltage(Vcm=+1.2V)		100	[mV]
Vtl	Differential Input Low Voltage(Vcm=+1.2V)	-100		[mV]

LVDS Macro AC characteristics are as follows:

	Min.	Max.
Clock Frequency (T)	50MHZ	85MHZ
Data Setup Time (Tsu)	1ns	
Data Hold Time (Thd)	1ns	

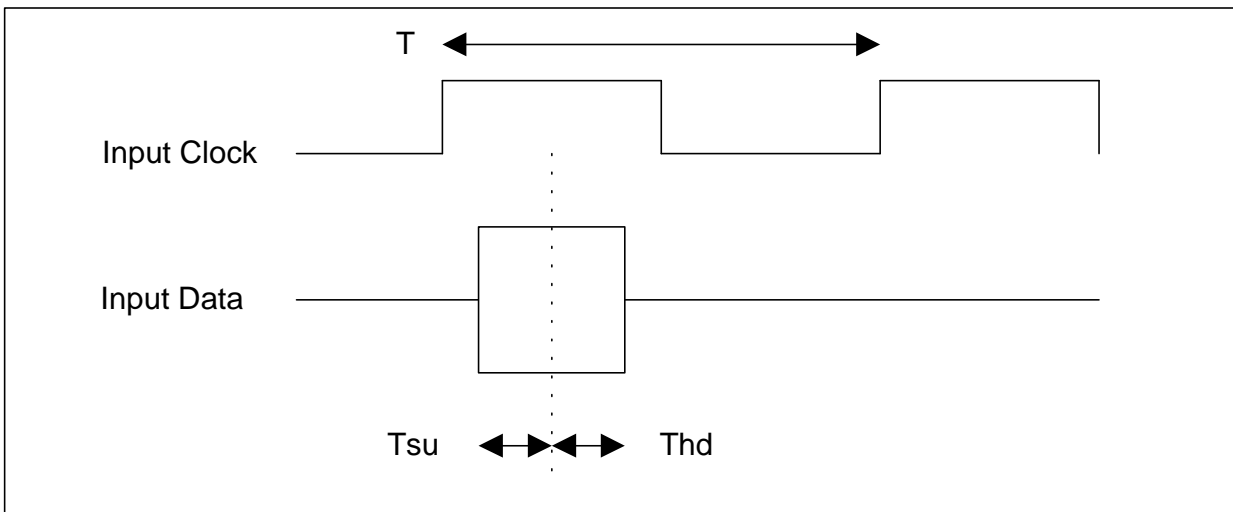

### 5.5 Signal for Lamp connector

Pin #	Signal Name
1	Lamp High Voltage
2	Lamp Low Voltage

## 6.0 Pixel Format Image

Following figure shows the relationship of the input signals and LCD pixel format.

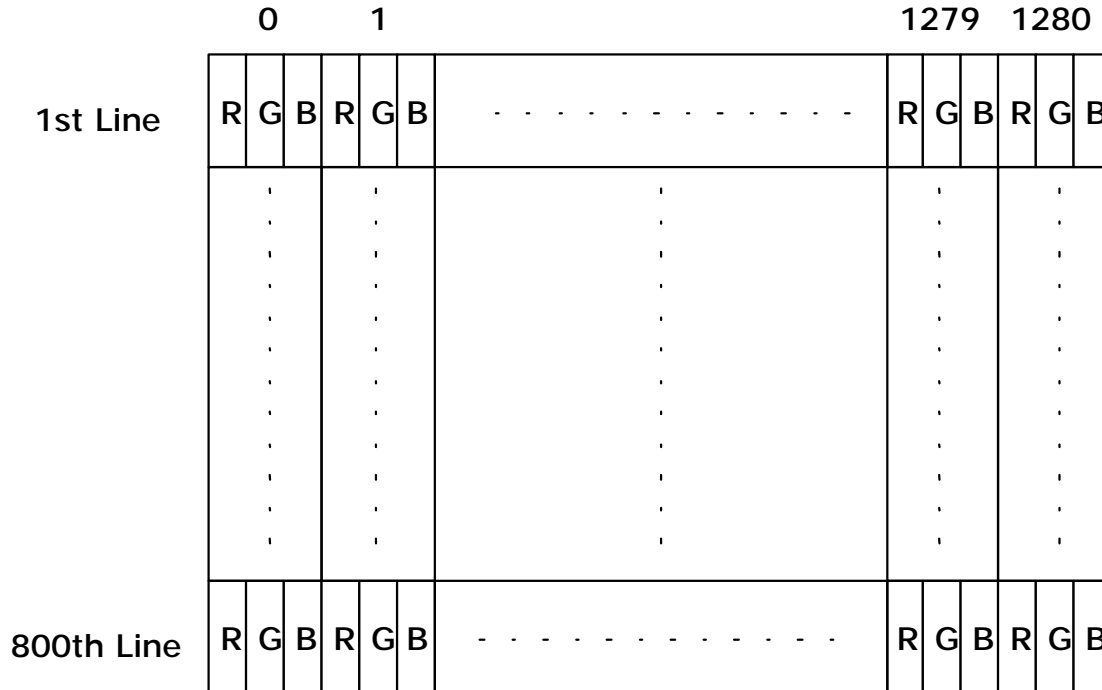

## 7.0 Parameter guide line for CFL Inverter

Parameter	Min	DP-1	Max	Units	Condition
White Luminance 5 points average	-	220	—	[cd/m <sup>2</sup> ]	(Ta=25°C)
CCFL current(ICFL)	3.0	6.0	6.5	[mA] rms	(Ta=25°C) Note 2
CCFL Frequency(FCFL)	50	60	70	[KHz]	(Ta=25°C) Note 3,4
CCFL Ignition Voltage(Vs)		991		[Volt] rms	(Ta= 0°C) Note 5
CCFL Voltage (Reference) (VCFL)	648	720	792	[Volt] rms	(Ta=25°C) Note 6
CCFL Power consumption (PCFL)	3.87	4.3	4.73	[Watt]	(Ta=25°C) Note 6

Note 1: DP-1 are AUO recommended Design Points.

\*1 All of characteristics listed are measured under the condition using the AUO Test inverter.

\*2 In case of using an inverter other than listed, it is recommended to check the inverter carefully. Sometimes, interfering noise stripes appear on the screen, and substandard luminance or flicker at low power may happen.

\*3 In designing an inverter, it is suggested to check safety circuit very carefully. Impedance of CFL, for instance, becomes more than 1 [M ohm] when CFL is damaged.

\*4 Generally, CFL has some amount of delay time after applying kick-off voltage. It is recommended to keep on applying kick-off voltage for 1 [Sec] until discharge.

\*5 CFL discharge frequency must be carefully chosen so as not to produce interfering noise stripes on the screen.

\*6 Reducing CFL current increases CFL discharge voltage and generally increases CFL discharge frequency. So all the parameters of an inverter should be carefully designed so as not to produce too much leakage current from high-voltage output of the inverter.

Note 2: It should be employed the inverter which has "Duty Dimming", if ICFL is less than 4mA.

Note 3: CFL discharge frequency should be carefully determined to avoid interference between inverter and TFT LCD.

Note 4: The frequency range will not affect to lamp life and reliability characteristics.

Note 5: CFL inverter should be able to give out a power that has a generating capacity of over 1,400 voltage. Lamp units need 1,400 voltage minimum for ignition.

Note 6: Calculator value for reference ( $ICFL \times VCFL = PCFL$ )

## 8.0 Interface Timings

Basically, interface timings should match the 1280x800 /60Hz manufacturing guide line timing.

### 8.1 Timing Characteristics

Parameter	Symbol	Min.	Typ.	Max.	Unit	Condition	
Clock frequency	$1/T_{Clock}$	50	68.9	85	MHz		
Vertical Section	Period	$T_V$	803	816	832	$T_{Line}$	
	Active	$T_{VD}$	800	800	800		
	Blanking	$T_{VB}$	3	16	32		
Horizontal Section	Period	$T_H$	1302	1408	1700	$T_{Clock}$	
	Active	$T_{HD}$	1280	1280	1280		
	Blanking	$T_{HB}$	22	128	420		
End-frame checking period	tEF	2			$T_{Line}$		
DE checking period	tDE	6400			$T_{Line}$	8 Frames	

## 8.2 Timing Definition

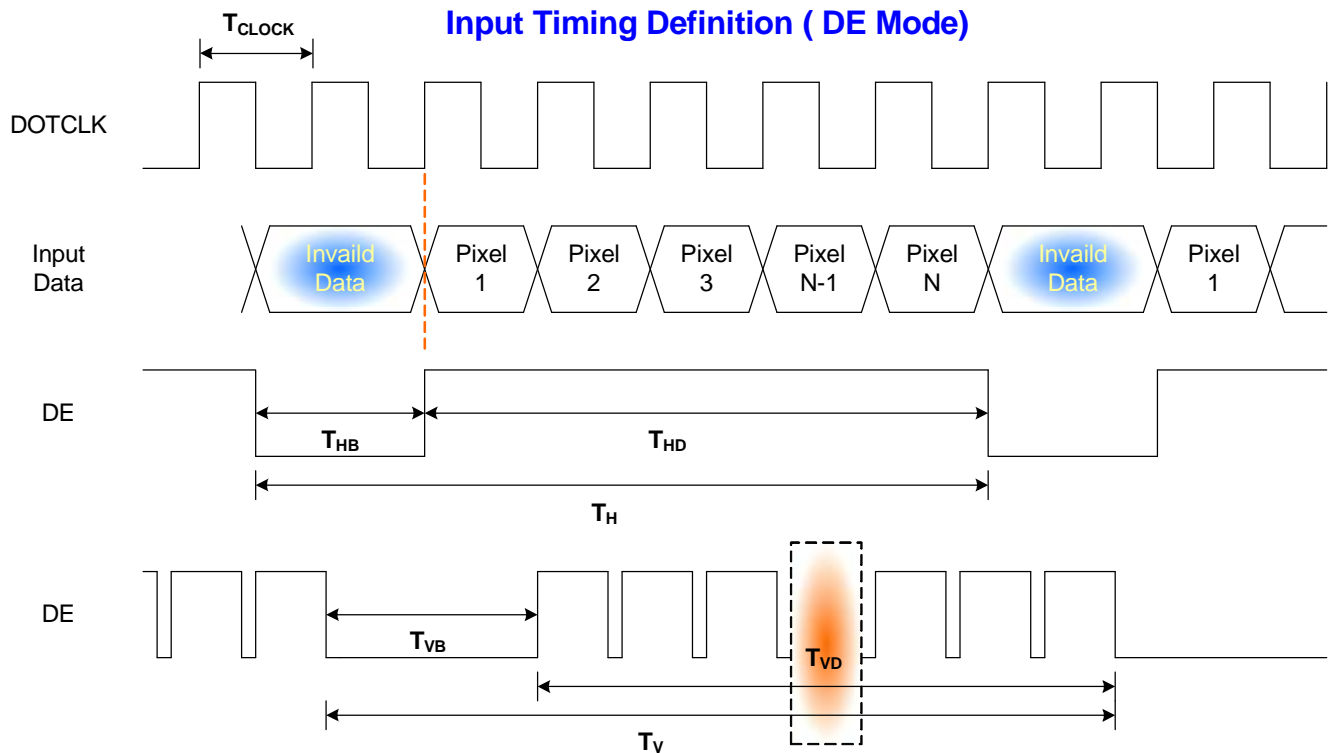

## 9.0 Power Consumption

Input power specifications are as follows;

Symble	Parameter	Min	Typ	Max	Units	Condition
VDD	Logic/LCD Drive Voltage	3.0	3.3	3.6	[Volt]	Load Capacitance 20uF
PDD	VDD Power		2		[Watt]	All Black Pattern
PDD Max	VDD Power max			2	[Watt]	Max Pattern Note
IDD	IDD Current		500		mA	All Black Pattern
IDD Max	IDD Current max			600	mA	Max Pattern Note
IRush	Inrush Current			1800	mA	
VDDrp	Allowable Logic/LCD Drive Ripple Voltage			100	[mV] p-p	
VDDns	Allowable Logic/LCD Drive Ripple Noise			100	[mV] p-p	

Note : VDD=3.3V

(C) Copyright AU Optonics, Inc.

August, 2003 All Rights Reserved.

B154EW01 V1 Ver.6

# 10. Power ON/OFF Sequence

VDD power and lamp on/off sequence is as follows. Interface signals are also shown in the chart. Signals from any system shall be Hi-Z state or low level when VDD is off.

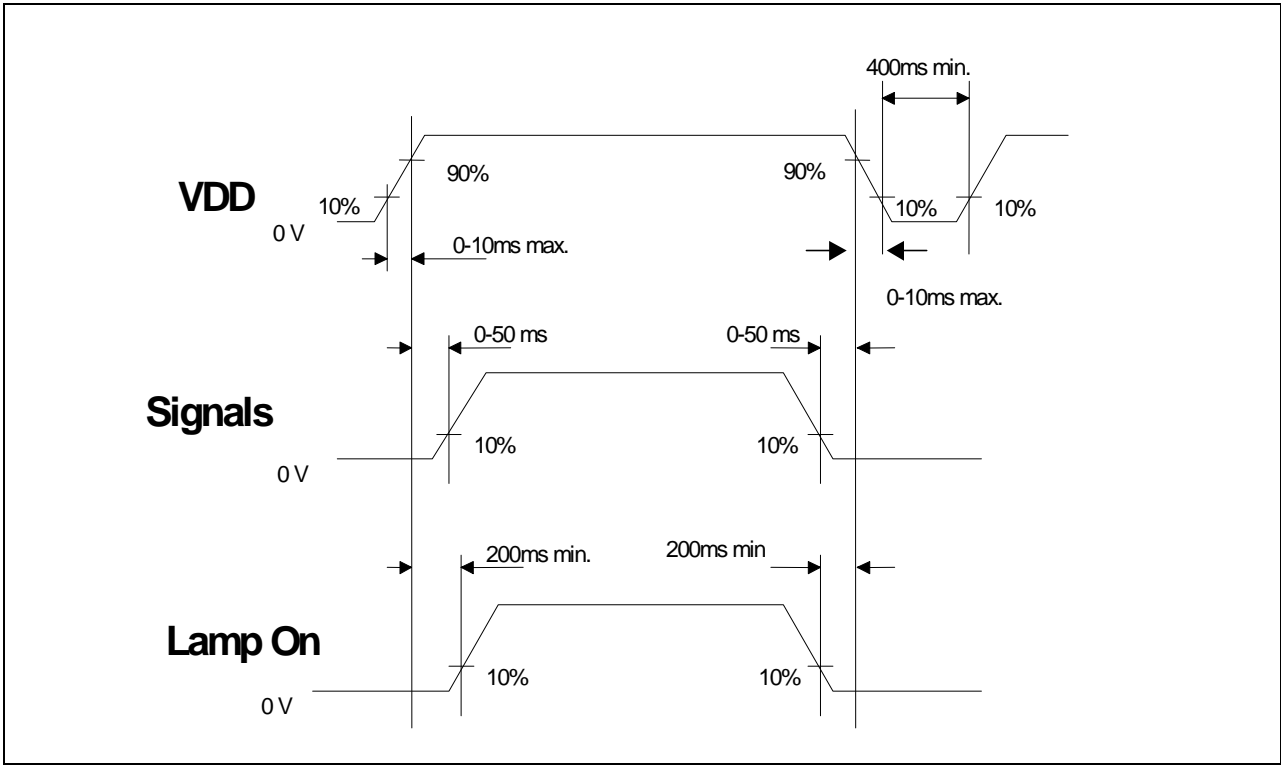

## 11.0 Reliability Test Condition

Items	Required Condition	Note
Temperature Humidity Bias	40°C/90%,300Hr	
High Temperature Operation	60°C/Dry,300Hr	
Low Temperature Operation	0°C,300Hr	
On/Off Test	25°C,150hrs(ON/10 sec. OFF/10sec., 10,000 cycles)	
Hot Storage	60°C/35% RH ,250 hours	
Cold Storage	-20°C/50% RH ,250 hours	
Thermal Shock Test	-20°C/30 min ,60°C/30 min 100cycles	
Hot Start Test	50°C/1 Hr min. power on/off per 5 minutes, 5 times	
Cold Start Test	0°C/1 Hr min. power on/off per 5 minutes, 5 times	
Shock Test (Non-Operating)	220G, 2ms, Half-sine wave	
Vibration Test (Non-Operating)	Random vibration, 1.5 G zero-to-peak, 10 to 500 Hz, 30 mins in each of three mutually perpendicular axes.	
ESD	Contact : ±8KV/ operation Air : ±15KV / operation	Note 1
Room temperature Test	25°C, 2000hours, Operating with loop pattern	

Note1: Some performance degradation allowed. No data lost. Self-recoverable. No hardware failures.









## 12.2 Screw Hole Depth and Center Position

Screw hole minimum depth, from side surface = 2.5 mm (See drawing)

Screw hole center location, from front surface =  $3.7 \pm 0.2$ mm (See drawing)

Screw Torque: Maximum 2.5 kgf-cm

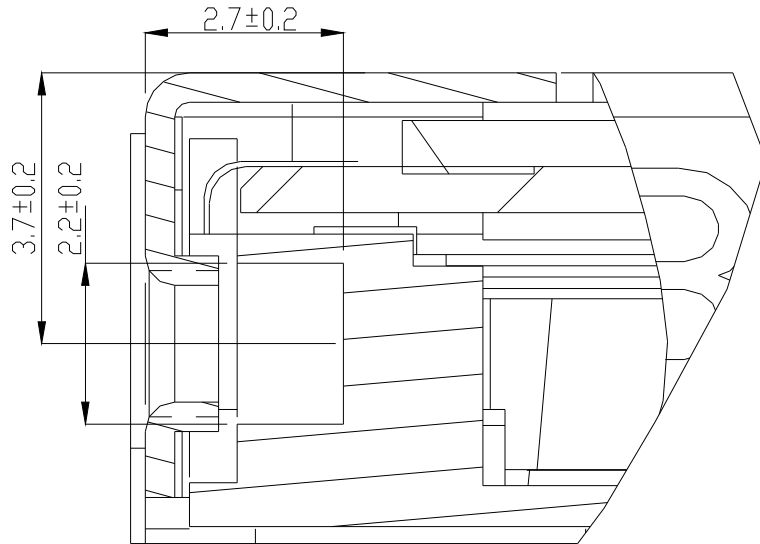

DETAIL A  
SCALE 10.000

# 13. Shipping Label Format

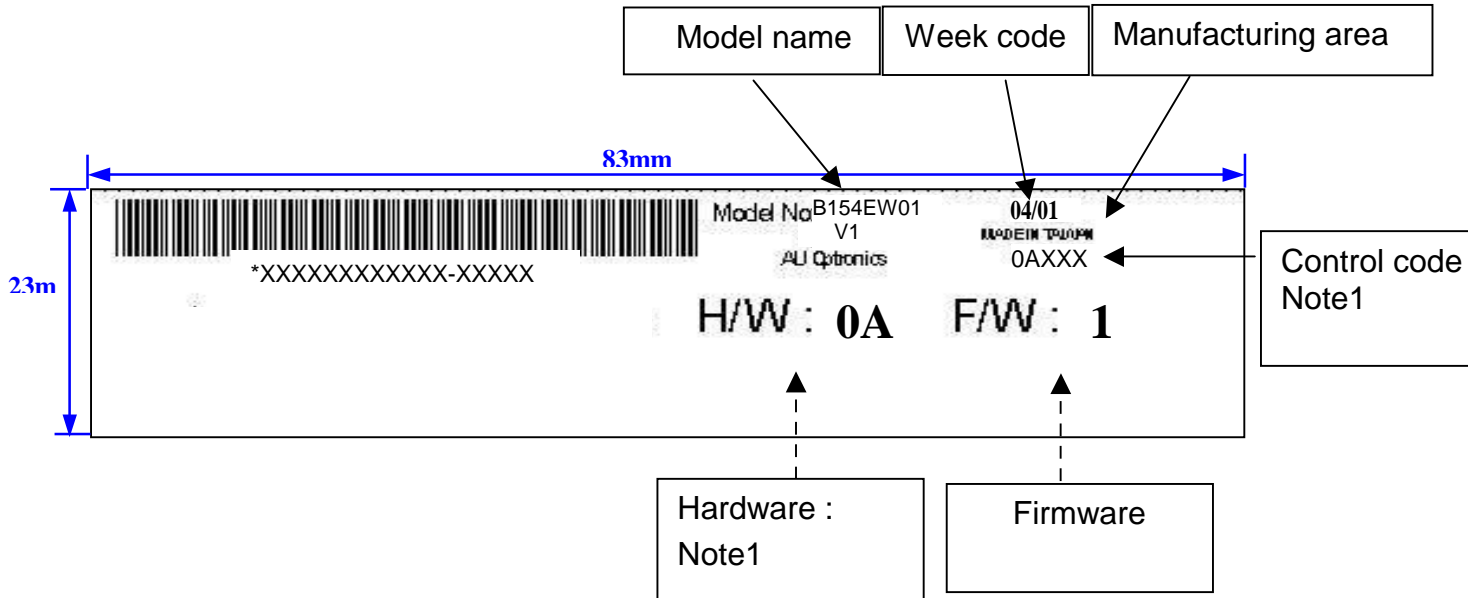

Note 1:

IC combination	Control Code	H/W
Source IC: NT 39360 Gate IC: NT 3959A	0AXXX	0A
Source IC: TSB T6L92A Gate IC: NEC uPD160703	1AXXX	1A

## 14. Carton package

The outside dimension of carton is 455 (L)mm x 380 (W)mm x 355 (H)mm

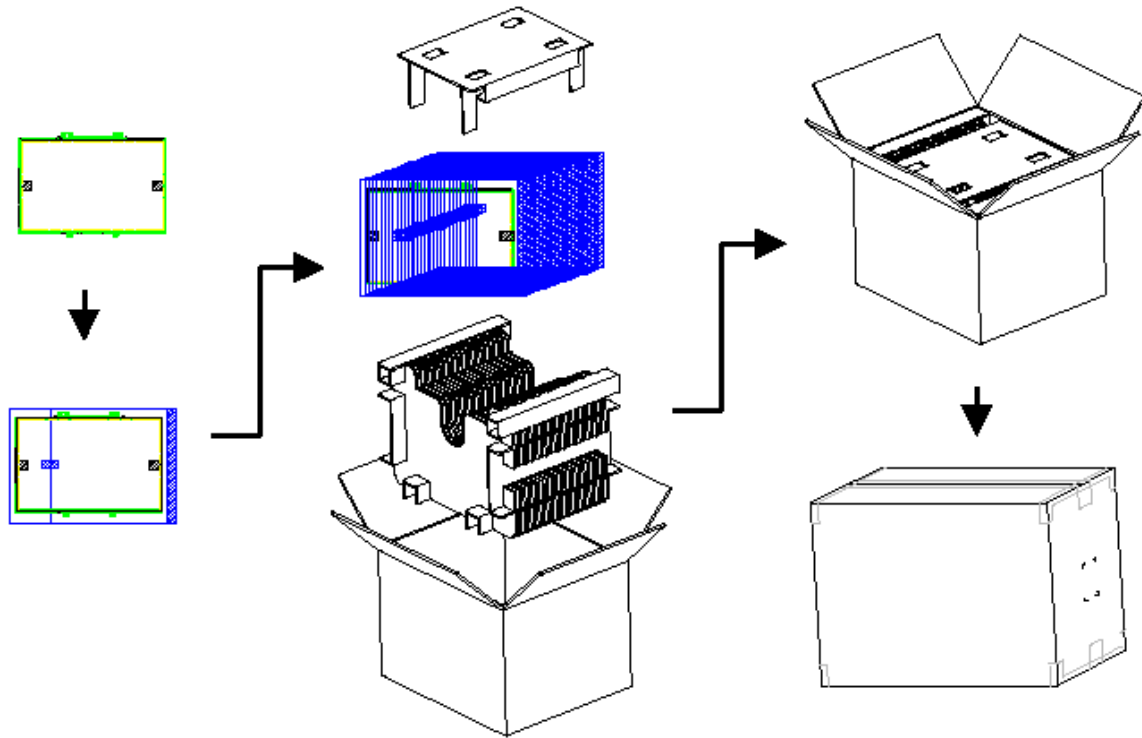

# 15. Shipping package of palletizing sequence

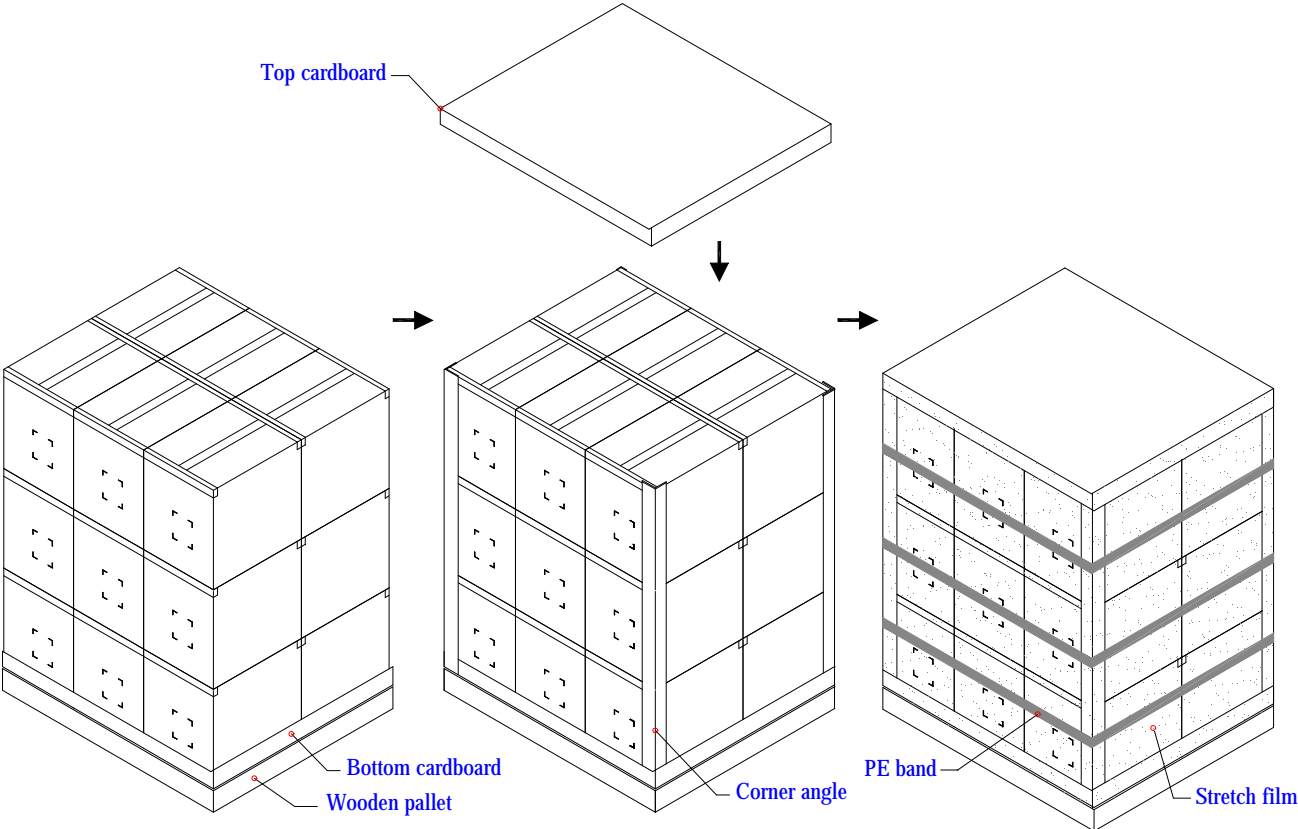

Note : Limit of box palletizing = Max 3 layers(ship and stock conditions)

## 16.0 Appendix: EDID descriptipn

B154EW01 EDID Table					
Address HEX	FUNCTION	Value HEX	Value BIN	Value DEC	Notes
00	Header	00	00000000	0	
01		FF	11111111	255	
02		FF	11111111	255	
03		FF	11111111	255	
04		FF	11111111	255	
05		FF	11111111	255	
06		FF	11111111	255	
07		00	00000000	0	
08	EISA Manuf. Code LSB	06	00000110	6	ASCII Data String:B154EW01
09	Compressed ASCII	AF	10101111	175	AUO
0A	Product Code	0D	00001101	13	13(15B13)
0B	hex, LSB first	0F	00001111	15	15(15B13)
0C	32-bit ser #	01	00000001	1	unused
0D		01	00000001	1	
0E		01	00000001	1	
0F		01	00000001	1	
10	Week of manufacture	2A	00101010	42	Week 42
11	Year of manufacture	0D	00001101	13	13(2003-1990=13)
12	EDID Structure Ver.	01	00000001	1	
13	EDID revision #	03	00000011	3	
14	Video input definition	80	10000000	128	Digital Input
15	Max H image size	21	00100001	33	33.12cm
16	Max V image size	15	00010101	21	20.7cm
17	Display Gamma	78	01111000	120	Gamma 2.2
18	Feature support	0A	00001010	10	no DPMS,Active off,RGB color
19	Red/green low bits	47	01000111	71	
1A	Blue/white low bits	A0	10100000	160	
1B	Red x/ high bits	99	10011001	153	Rx=0.6
1C	Red y	59	01011001	89	Ry=0.35

(C) Copyright AU Optronics, Inc.  
August, 2003 All Rights Reserved.

B154EW01 V1 Ver.6

31/34

No Reproduction and Redistribution Allowed.

1D	Green x	4F	01001111	79	Gx=0.310
1E	Green y	8C	10001100	140	Gy=0.550
1F	Blue x	26	00100110	38	Bx=0.15
20	Blue y	1D	00011101	29	By=0.115
21	White x	50	01010000	80	Wx=0.313
22	White y	54	01010100	84	Wy=0.329
23	Established timing 1	00	00000000	0	unused
24	Established timing 2	00	00000000	0	
25	Manufacturer's Timing	00	00000000	0	
26	Standard timing #1	01	00000001	1	unused
27		01	00000001	1	
28	Standard timing #2	01	00000001	1	
29		01	00000001	1	
2A	Standard timing #3	01	00000001	1	
2B		01	00000001	1	
2C	Standard timing #4	01	00000001	1	
2D		01	00000001	1	
2E	Standard timing #5	01	00000001	1	
2F		01	00000001	1	
30	Standard timing #6	01	00000001	1	
31		01	00000001	1	
32	Standard timing #7	01	00000001	1	
33		01	00000001	1	
34	Standard timing #8	01	00000001	1	
35		01	00000001	1	
36	Pixel Clock/10,000 (LSB)	EA	11101010	234	Timing Descriptor #1
37	Pixel Clock/10,000 (MSB)	1A	00011010	26	1280x800 @60_mode:pixel clock=68.9MHz
38	Horiz. Active pixels(Lower 8 bits)	00	00000000	0	Horiz active=1280 pixels
39	Horiz.Blanking (Lower 8 bits)	80	10000000	128	Horiz blanking=128 pixels
3A	Horiz. Active pixels:Horiz. Blanking (Upper4:4 bits)	50	01010000	80	
3B		20	00100000	32	Vertical active=800 lines
3C		10	00010000	16	Vertical blanking=16 lines
3D	Vert. Active pixels:Vert. Blanking (Upper4:4 bits)	30	00110000	48	
3E		15	00010101	21	Horiz sync. Offset=21 pixels



3F		20	00100000	32	Horiz sync. Pulse Width=32 pixels
40	Vert. Sync. Offset=xx lines, Sync Width=xx lines	44	01000100	68	Verti sync. Offset=4 lines, Sync Width=4 lines
41	Horz. Ver. Sync/Width (upper 2 bits)	00	00000000	0	
42	Hori. Image size (Lower 8 bits)	4B	01001011	75	Hori image size= 331 mm
43	Vert. Image size (Lower 8 bits)	CF	11001111	207	Verti image size = 207mm
44	Hori. Image size : Vert. Image size (Upper 4 bits)	10	00010000	16	
45		00	00000000	0	Horizontal Border = 0
46		00	00000000	0	Vertical Border = 0
47		18	00011000	24	
48	Detailed timing/monitor	00	00000000	0	ASCII Data String:B154EW01
49	descriptor #2	00	00000000	0	
4A		00	00000000	0	
4B		0F	00001111	15	
4C		0	00000000	0	
4D		42	01000010	66	B
4E		31	00110001	49	1
4F		35	00110101	53	5
50		34	00110100	52	4
51		45	01000101	69	E
52		57	01010111	87	W
53		30	00110000	48	0
54		31	00110001	49	1
55		0A	00001010	10	
56		20	00100000	32	
57		20	00100000	32	
58		20	00100000	32	
59		20	00100000	32	EDID VERSION.
5A	Detailed timing/monitor	00	00000000	0	ASCII Data String:B154EW01
5B	descriptor #3	00	00000000	0	
5C		00	00000000	0	
5D		FE	11111110	254	
5E		0	00000000	0	
5F		41	01000001	65	A
60		55	01010101	85	U

61		4F	01001111	79	O
62		0A	00001010	10	
63		20	00100000	32	
64		20	00100000	32	
65		20	00100000	32	
66		20	00100000	32	
67		20	00100000	32	
68		20	00100000	32	
69		20	00100000	32	
6A		20	00100000	32	
6B		20	00100000	32	
6C	Detailed timing/monitor	00	00000000	0	Monitor Name: Color LCD
6D	descriptor #4	00	00000000	0	
6E		00	00000000	0	
6F		FE	11111110	254	
70		00	00000000	0	
71		42	01000010	66	B
72		31	00110001	49	1
73		35	00110101	53	5
74		34	00110100	52	4
75		45	01000101	69	E
76		57	01010111	87	W
77		30	00110000	48	0
78		31	00110001	49	1
79		0A	00001010	10	
7A		20	00100000	32	
7B		20	00100000	32	
7C		20	00100000	32	
7D		20	00100000	32	
7E	Extension Flag	00	00000000	0	
7F	Checksum	44	01000100	68	Check sum