



# Product Specification

AU OPTRONICS CORPORATION

B154EW07 V2

( V ) Preliminary Specifications  
( ) Final Specifications

<b>Module</b>	15.4" WXGA Color TFT-LCD
<b>Model Name</b>	B154EW07 V2

<b>Customer</b>	<b>Date</b>
_____	_____
<b>Checked &amp; Approved by</b>	
_____	_____

Note: This Specification is subject to change without notice.

<b>Approved by</b>	<b>Date</b>
_____	_____
<b>Prepared by</b>	
_____	_____

MDBU Marketing Division /  
AU Optronics corporation



## Contents

<b>1. Handling Precautions</b> .....	<b>4</b>
<b>2. General Description</b> .....	<b>5</b>
2.1 General Specification .....	5
2.2 Optical Characteristics .....	6
<b>3. Functional Block Diagram</b> .....	<b>11</b>
<b>4. Absolute Maximum Ratings</b> .....	<b>12</b>
4.1 Absolute Ratings of TFT LCD Module .....	12
4.2 Absolute Ratings of Backlight Unit .....	12
<b>5. Electrical characteristics</b> .....	<b>13</b>
5.1 TFT LCD Module .....	13
5.2 Backlight Unit .....	15
<b>6. Signal Characteristic</b> .....	<b>17</b>
6.1 Pixel Format Image .....	17
6.2 The input data format .....	18
6.3 Signal Description/Pin Assignment .....	19
6.4 Interface Timing .....	21
<b>7. Connector Description</b> .....	<b>24</b>
7.1 TFT LCD Module .....	24
7.2 Backlight Unit .....	24
7.3 Signal for Lamp connector .....	24
<b>8. Reliability</b> .....	<b>25</b>
<b>9. Mechanical Characteristics</b> .....	<b>27</b>
9.1 LCM Outline Dimension .....	27
9.2 Screw Hole Depth and Center Position .....	29
<b>10. Shipping and Package</b> .....	<b>30</b>
10.1 Shipping Label Format .....	30
10.2. Carton package .....	31
11.3 Shipping package of palletizing .....	31
<b>11. Appendix: EDID description</b> .....	<b>32</b>



# Product Specification

AU OPTRONICS CORPORATION

B154EW07 V2

## Record of Revision

Version and Date	Page	Old description	New Description	Remark
0.1 2007/02/09	All	Initialize the Preliminary Specification		



## 1. Handling Precautions

- 1) Since front polarizer is easily damaged, pay attention not to scratch it.
- 2) Be sure to turn off power supply when inserting or disconnecting from input connector.
- 3) Wipe off water drop immediately. Long contact with water may cause discoloration or spots.
- 4) When the panel surface is soiled, wipe it with absorbent cotton or other soft cloth.
- 5) Since the panel is made of glass, it may break or crack if dropped or bumped on hard surface.
- 6) Since CMOS LSI is used in this module, take care of static electricity and insure human earth when handling.
- 7) Do not open nor modify the Module Assembly.
- 8) Do not press the reflector sheet at the back of the module to any directions.
- 9) In case if a Module has to be put back into the packing container slot after once it was taken out from the container, do not press the center of the CCFL Reflector edge. Instead, press at the far ends of the CFL Reflector edge softly. Otherwise the TFT Module may be damaged.
- 10) At the insertion or removal of the Signal Interface Connector, be sure not to rotate nor tilt the Interface Connector of the TFT Module.
- 11) After installation of the TFT Module into an enclosure (Notebook PC Bezel, for example), do not twist nor bend the TFT Module even momentary. At designing the enclosure, it should be taken into consideration that no bending/twisting forces are applied to the TFT Module from outside. Otherwise the TFT Module may be damaged.
- 12) Cold cathode fluorescent lamp in LCD contains a small amount of mercury. Please follow local ordinances or regulations for disposal.
- 13) Small amount of materials having no flammability grade is used in the LCD module. The LCD module should be supplied by power complied with requirements of Limited Power Source (, IEC60950 or UL1950), or be applied exemption.
- 14) The LCD module is designed so that the CCFL in it is supplied by Limited Current Circuit (IEC60950 or UL1950). Do not connect the CCFL in Hazardous Voltage Circuit.



# Product Specification

AU OPTRONICS CORPORATION

B154EW07 V2

## 2. General Description

B154EW07 V2 is a Color Active Matrix Liquid Crystal Display composed of a TFT LCD panel, a driver circuit, and backlight system. The screen format is intended to support the WXGA (1280(H) x 800(V)) screen and 262k colors (RGB 6-bits data driver). All input signals are LVDS interface compatible. Inverter of backlight is not included.

B154EW07 V2 is designed for a display unit of notebook style personal computer and industrial machine.

## 2.1 General Specification

The following items are characteristics summary on the table at 25 °C condition:

Items	Unit	Specifications
Screen Diagonal	[mm]	391.16
Active Area	[mm]	331.2 X 207.0
Pixels H x V		1280 x 3(RGB) x 800
Pixel Pitch	[mm]	0.2588X0.2588
Pixel Arrangement		R,G,B Vertical Stripe
Display Mode	—	Normally White
White Luminance (I <sub>CCFL</sub> =6.0mA) Note: I <sub>CCFL</sub> is lamp current	[cd/m <sup>2</sup> ]	500 typ. (5 points average) 425 min. (5 points average) (Note1)
Luminance Uniformity		TBD
Contrast Ratio		500 typ.
Optical Rise Time/Fall Time	[msec]	8 typ.
Nominal Input Voltage VDD	[Volt]	+3.3 typ.
Power Consumption	[Watt]	TBD
Weight (Without Inverter)	[Grams]	565 typ., 580 max.
Physical Size	[mm]	344.5 max.(W) x 225.5 max.(H) x 6.5 max.(T)
Electrical Interface		6bit, 1 channel LVDS
Surface Treatment		Glare, Hardness 3H
Support Color		Native 262K colors (RGB 6-bit data)
Temperature Range Operating	[°C]	0 to +50
Storage (Non-Operating)	[°C]	-20 to +60
RoHS Compliance		RoHS Compliance



# Product Specification

AU OPTRONICS CORPORATION

B154EW07 V2

## 2.2 Optical Characteristics

The optical characteristics are measured under stable conditions at 25°C (Room Temperature):

Item	Unit	Conditions	Min.	Typ.	Max.	Note
White Luminance I <sub>CCFL</sub> =6.0mA	[cd/m <sup>2</sup> ]	5 points average	425	500	-	1, 4, 5.
Viewing Angle	[degree]	Horizontal (Right) CR = 10 (Left)	60	70	-	9
	[degree]		60	70	-	
	[degree]	Vertical (Upper) CR = 10 (Lower)	50	60	-	
	[degree]		50	60	-	
Luminance Uniformity		5 Points			TBD	1
Luminance Uniformity		13 Points			TBD	2
CR: Contrast Ratio			TBD	500	-	6
Cross talk	%				4	7
Response Time	[msec]	Rising	-	TBD	TBD	8
	[msec]	Falling	-	TBD	TBD	
	[msec]	Rising + Falling		8	TBD	
Color / Chromaticity Coordinates (CIE 1931)		Red x	TBD	TBD	TBD	2,9
		Red y	TBD	TBD	TBD	
		Green x	TBD	TBD	TBD	
		Green y	TBD	TBD	TBD	
		Blue x	TBD	TBD	TBD	
		Blue y	TBD	TBD	TBD	
		White x	0.283	0.313	0.343	
		White y	0.299	0.329	0.359	
NTSC Ratio	%	CIE 1931	TBD	72	-	

Note 1: 5 points position (Display area : 331.2 (H) x 207.0 (V)mm)

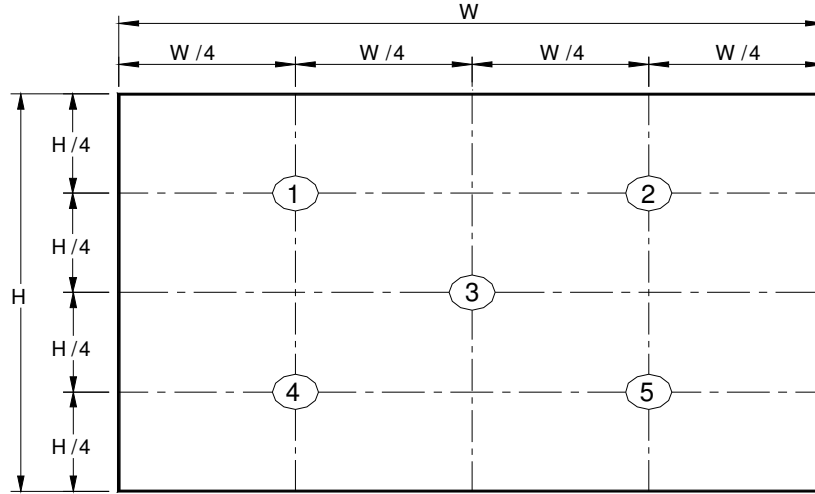

Note 2: 13 points position

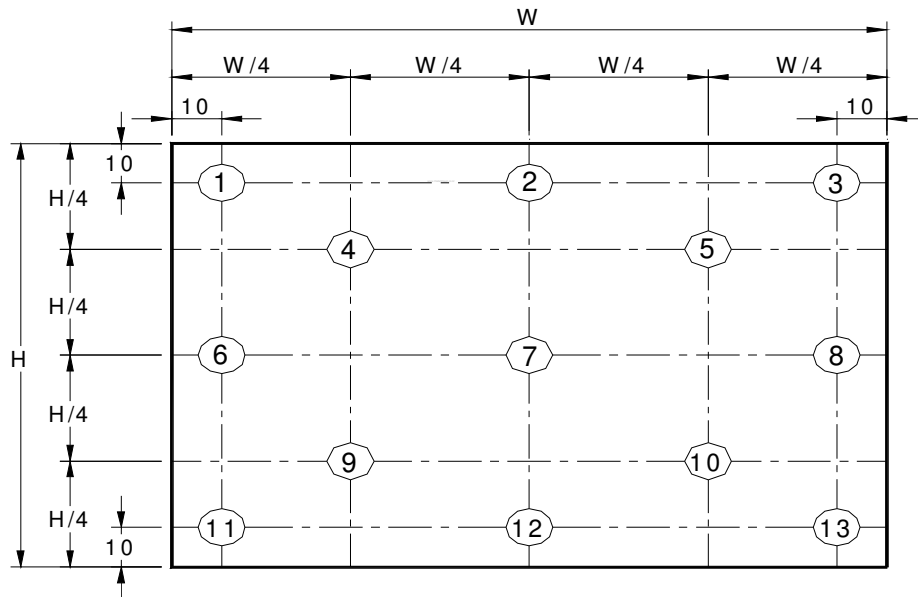

Note 3: The luminance uniformity of 5 and 13 points is defined by dividing the maximum luminance values by the minimum test point luminance

$$\delta_{W5} = \frac{\text{Maximum Brightness of five points}}{\text{Minimum Brightness of five points}}$$

$$\delta_{W13} = \frac{\text{Maximum Brightness of thirteen points}}{\text{Minimum Brightness of thirteen points}}$$

Note 4: Measurement method

The LCD module should be stabilized at given temperature for 30 minutes to avoid abrupt temperature change during measuring. In order to stabilize the luminance, the measurement should be executed after lighting Backlight for 30 minutes in a stable, windless and dark room.

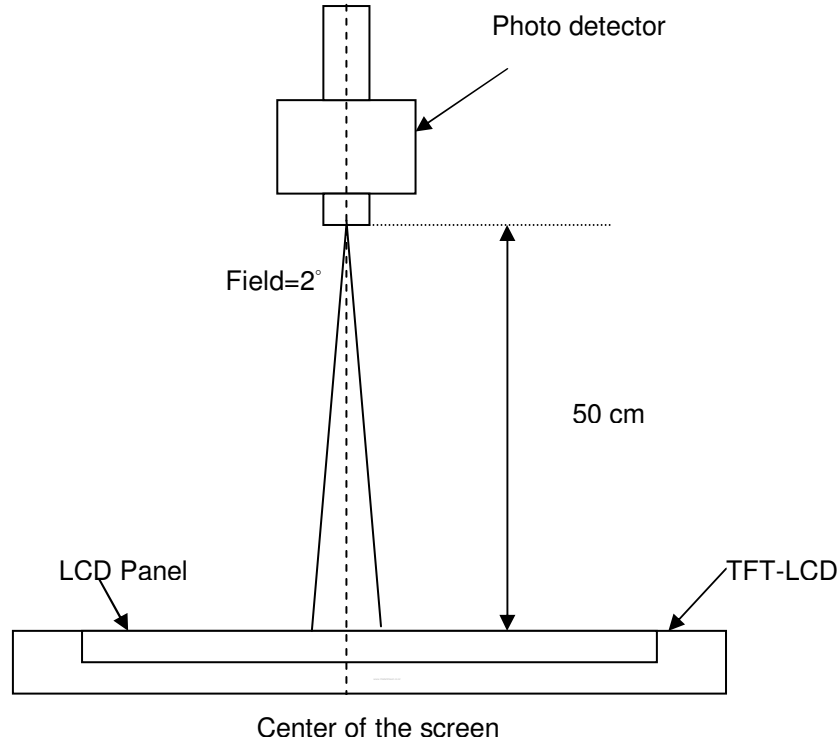

Note 5: Definition of Average Luminance of White ( $Y_L$ ):

Measure the luminance of gray level 63 at 5 points ·  $Y_L = [L (1)+ L (2)+ L (3)+ L (4)+ L (5)] / 5$

$L (x)$  is corresponding to the luminance of the point X at Figure in Note (1).

Note 6: Definition of contrast ratio:

Contrast ratio is calculated with the following formula.

$$\text{Contrast ratio (CR)} = \frac{\text{Brightness on the "White" state}}{\text{Brightness on the "Black" state}}$$



Note 7 : Definition of Cross Talk (CT)

$$CT = | Y_B - Y_A | / Y_A \times 100 (\%)$$

Where

$Y_A$  = Luminance of measured location without gray level 0 pattern (cd/m<sup>2</sup>)

$Y_B$  = Luminance of measured location with gray level 0 pattern (cd/m<sup>2</sup>)

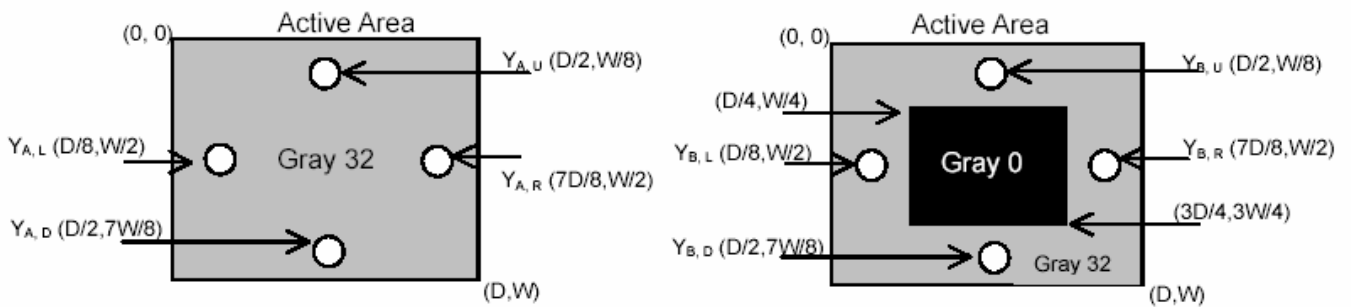

Note 8: Definition of response time:

The output signals of BM-7 or equivalent are measured when the input signals are changed from "Black" to "White" (falling time) and from "White" to "Black" (rising time), respectively. The response time interval is between the 10% and 90% of amplitudes. Refer to figure as below.

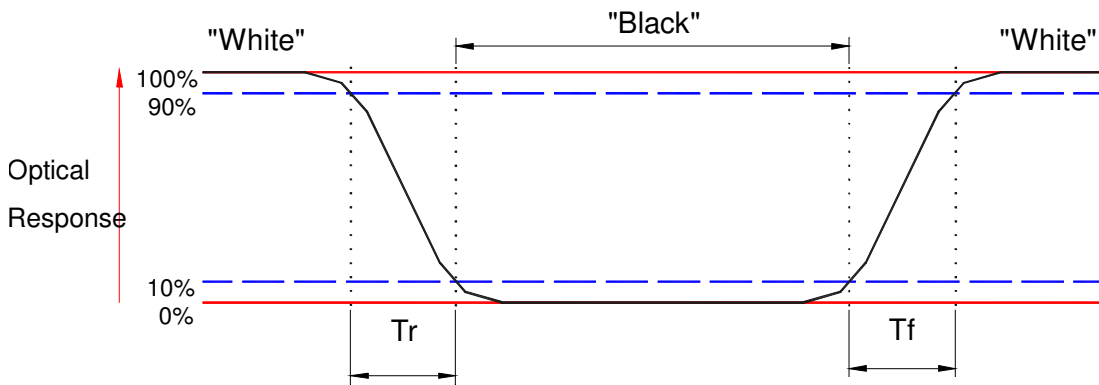

Note 9: Definition of viewing angle

Viewing angle is the measurement of contrast ratio  $\geq 10$ , at the screen center, over a 180° horizontal and 180° vertical range (off-normal viewing angles). The 180° viewing angle range is broken down as follows; 90° ( $\theta$ ) horizontal left and right and 90° ( $\Phi$ ) vertical, high (up) and low (down). The measurement direction is typically perpendicular to the display surface with the screen rotated about its center to develop the desired measurement viewing angle.

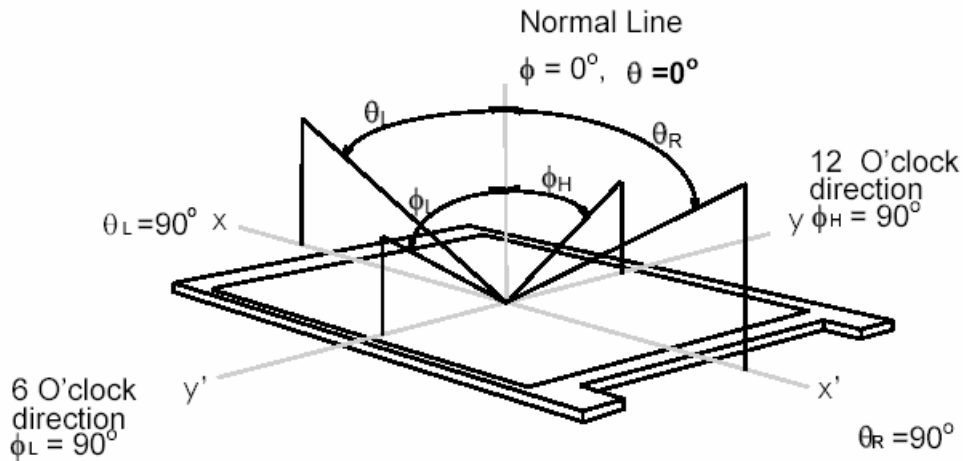

## 3. Functional Block Diagram

The following diagram shows the functional block of the 15.4 inches wide Color TFT/LCD Module:

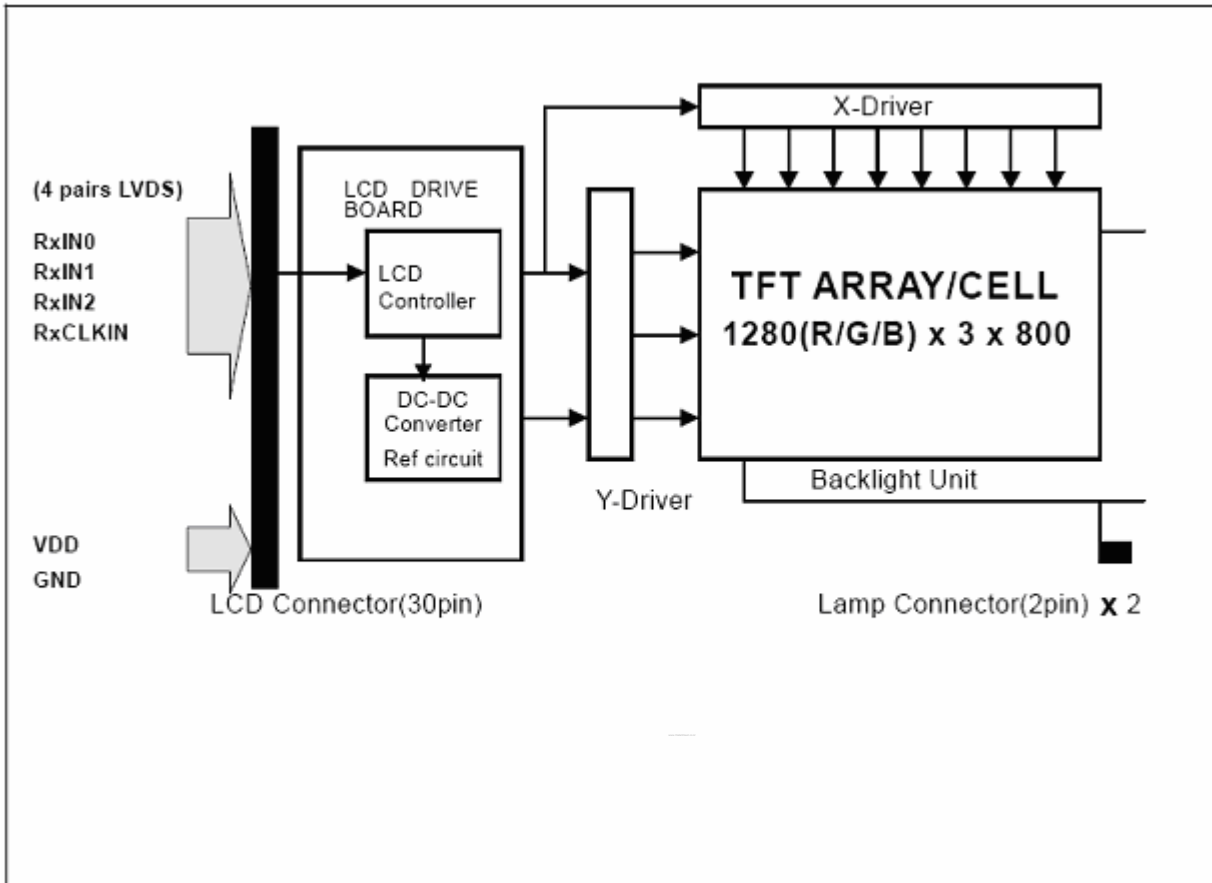

## 4. Absolute Maximum Ratings

Absolute maximum rating of the module is as following:

### 4.1 Absolute Ratings of TFT LCD Module

Item	Symbol	Min	Max	Unit	Conditions
Logic/LCD Drive	Vin	-0.3	+4.0	[Volt]	Note 1,2

### 4.2 Absolute Ratings of Backlight Unit

Item	Symbol	Min	Max	Unit	Conditions
CCFL Current	ICCFL	-	6.5	[mA] rms	Note 1,2

### 4.3 Absolute Ratings of Environment

Item	Symbol	Min	Max	Unit	Conditions
Operating	TOP	0	+50	[°C]	Note 3
Operation Humidity	HOP	5	95	[%RH]	Note 3
Storage	TST	-20	+60	[°C]	Note 3
Storage Humidity	HST	5	95	[%RH]	Note 3

Note 1: With in Ta (25°C )

Note 2: Permanent damage to the device may occur if exceed maximum values

Note 3: For quality performance, please refer to AUO IIS (Incoming Inspection Standard).

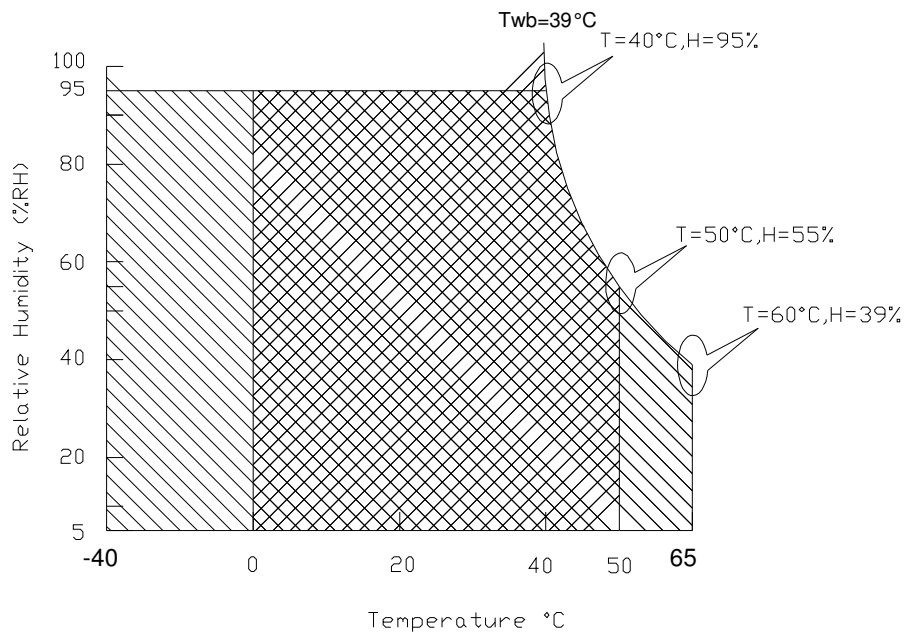

Operating Range



Storage Range

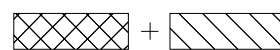



# Product Specification

AU OPTRONICS CORPORATION

B154EW07 V2

## 5. Electrical characteristics

### 5.1 TFT LCD Module

#### 5.1.1 Power Specification

Input power specifications are as follows:

Symble	Parameter	Min	Typ	Max	Units	Note
VDD	Logic/LCD Drive Voltage	3.0	3.3	3.6	[Volt]	
PDD	VDD Power			TBD	[Watt]	Note 1
IDD	IDD Current		TBD	TBD	[mA]	Note 1
IRush	Inrush Current			TBD	[mA]	Note 2
VDDrp	Allowable Logic/LCD Drive Ripple Voltage			TBD	[mV] p-p	

Note 1 : Maximum Measurement Condition : Black Pattern

Note 2 : Measure Condition

#### Planning

## 5.1.2 Signal Electrical Characteristics

Input signals shall be low or High-impedance state when VDD is off.

Signal electrical characteristics are as follows:

Parameter	Condition	Min	Max	Unit
Vth	Differential Input High Threshold (Vcm=+1.2V)	-	TBD	[mV]
Vtl	Differential Input Low Threshold (Vcm=+1.2V)	TBD	-	[mV]
Vcm	Differential Input Common Mode Voltage	TBD	TBD	[V]

Note: LVDS Differential Voltage

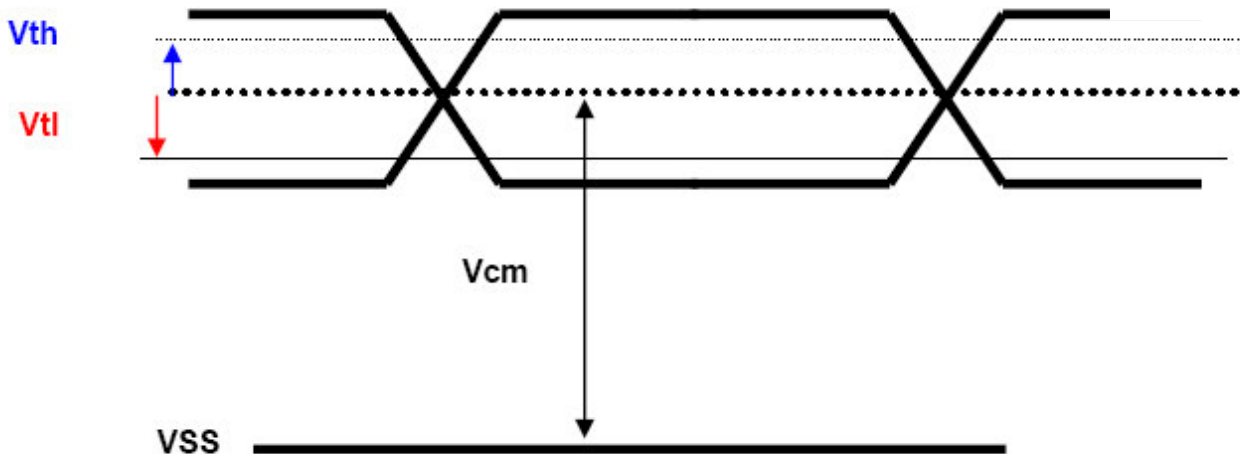

## 5.2 Backlight Unit

Parameter guideline for CCFL Inverter

Parameter	Min	Typ	Max	Units	Condition
CCFL current( $I_{CCFL}$ )	TBD	6.0	6.5	[mA] rms	( $T_a=25^{\circ}C$ ) Note 2
CCFL Frequency( $F_{CCFL}$ )	TBD	60	TBD	[KHz]	( $T_a=25^{\circ}C$ ) Note 3,4
CCFL Ignition Voltage( $V_s$ )	-	1310	1570	[Volt] rms	( $T_a=0^{\circ}C$ ) Note 5
CCFL Ignition Voltage( $V_s$ )	-	1050	1260	[Volt] rms	( $T_a=25^{\circ}C$ ) Note 5
CCFL Voltage (Reference) ( $V_{CCFL}$ )	630	700	770	[Volt] rms	( $T_a=25^{\circ}C$ ) Note 6
CCFL Power consumption ( $P_{CCFL}$ )	-	8.8	-	[Watt]	( $T_a=25^{\circ}C$ ) Note 6

Note 1: The below are AUO recommended Design Points.

- \*1 All of characteristics listed are measured under the condition using the AUO Test inverter.
- \*2 In case of using an inverter other than listed, it is recommended to check the inverter carefully.  
Sometimes, interfering noise stripes appear on the screen, and substandard luminance or flicker at low power may happen.
- \*3 In designing an inverter, it is suggested to check safety circuit very carefully. Impedance of CCFL, for instance, becomes more than 1 [M ohm] when CCFL is damaged.
- \*4 Generally, CCFL has some amount of delay time after applying kick-off voltage. It is recommended to keep on applying kick-off voltage for 1 [Sec] until discharge.
- \*5 CCFL discharge frequency must be carefully chosen so as not to produce interfering noise stripes on the screen.
- \*6 Reducing CCFL current increases CCFL discharge voltage and generally increases CCFL discharge frequency. All the parameters of an inverter should be carefully designed, so as not to produce too much leakage current from high-voltage output of the inverter.

Note 2: It should be employed the inverter which has "Duty Dimming", if  $I_{CCFL}$  is less than 4mA.

Note 3: CCFL discharge frequency should be carefully determined to avoid interference between inverter and TFT LCD.

Note 4: The frequency range will not affect to lamp life and reliability characteristics.

Note 5: CCFL inverter should be able to give out a power that has a generating capacity of over 1,600 voltage. Lamp units need 1,570 voltage minimum for ignition.

Note 6: Calculator value for reference ( $I_{CCFL} \times V_{CCFL} = P_{CCFL}$ )

Note 7: Requirements for a system inverter design, which is intended to have a better display performance, a better power efficiency and a more reliable lamp, are following.

It shall help increase the lamp lifetime and reduce leakage current.

- a. The asymmetry rate of the inverter waveform should be less than 10%.
- b. The distortion rate of the waveform should be within  $\sqrt{2} \pm 10\%$ .

\* Inverter output waveform had better be more similar to ideal sine wave.

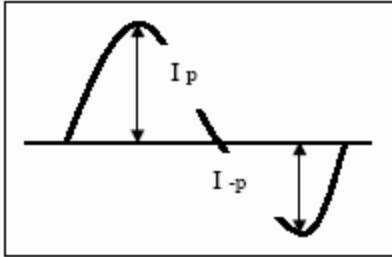

\* Asymmetry rate:

$$\frac{|I_p - I_{-p}|}{I_{rms}} * 100\%$$

\* Distortion rate

$$I_p \text{ (or } I_{-p}) / I_{rms}$$

Note 8: CCFL Life time: 10,000 hours minimum under normal module usage.





## 6.2 The input data format

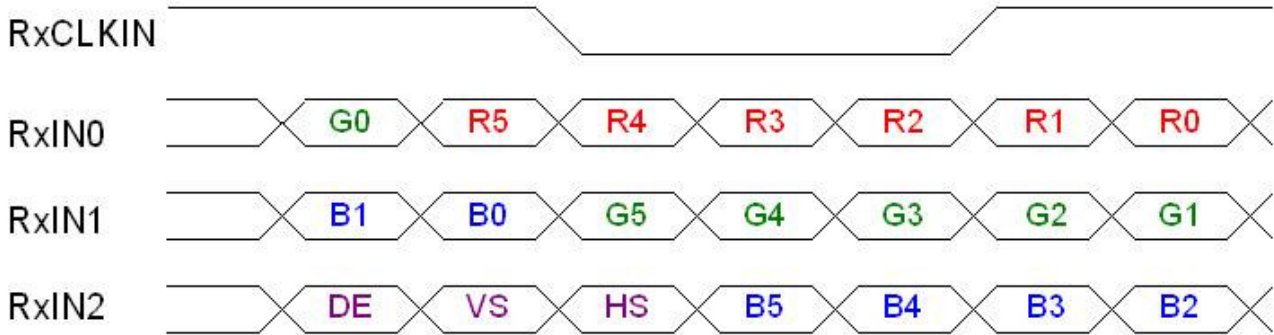

Signal Name	Description	
R5 R4 R3 R2 R1 R0	Red Data 5 (MSB) Red Data 4 Red Data 3 Red Data 2 Red Data 1 Red Data 0 (LSB) Red-pixel Data	Red-pixel Data Each red pixel's brightness data consists of these 6 bits pixel data.
G5 G4 G3 G2 G1 G0	Green Data 5 (MSB) Green Data 4 Green Data 3 Green Data 2 Green Data 1 Green Data 0 (LSB) Green-pixel Data	Green-pixel Data Each green pixel's brightness data consists of these 6 bits pixel data.
B5 B4 B3 B2 B1 B0	Blue Data 5 (MSB) Blue Data 4 Blue Data 3 Blue Data 2 Blue Data 1 Blue Data 0 (LSB) Blue-pixel Data	Blue-pixel Data Each blue pixel's brightness data consists of these 6 bits pixel data.
RxCLKIN	Data Clock	The typical frequency is 68.9 MHz. The signal is used to strobe the pixel data and DE signals. All pixel data shall be valid at the falling edge when the DE signal is high.
DE	Display Timing	This signal is strobed at the falling edge of RxCLKIN. When the signal is high, the pixel data shall be valid to be displayed.
VS	Vertical Sync	The signal is synchronized to RxCLKIN .
HS	Horizontal Sync	The signal is synchronized to RxCLKIN .

Note: Output signals from any system shall be low or High-impedance state when VDD is off.

## 6.3 Signal Description/Pin Assignment

LVDS is a differential signal technology for LCD interface and high speed data transfer device.

Pin#	Signal Name	Pin#	Signal Name
1	GND	2	VDD
3	VDD	4	VEDID
5	NC	6	CLKEDID
7	DATAEDID	8	RxIN0-
9	RxIN0+	10	GND
11	RxIN1-	12	RxIN1+
13	GND	14	RxIN2-
15	RxIN2+	16	GND
17	RxCLKIN-	18	RxCLKIN+
19	GND	20	GND
21	NC	22	NC
23	NC	24	NC
25	NC	26	NC
27	NC	28	NC
29	NC	30	NC

Note1: Start from right side

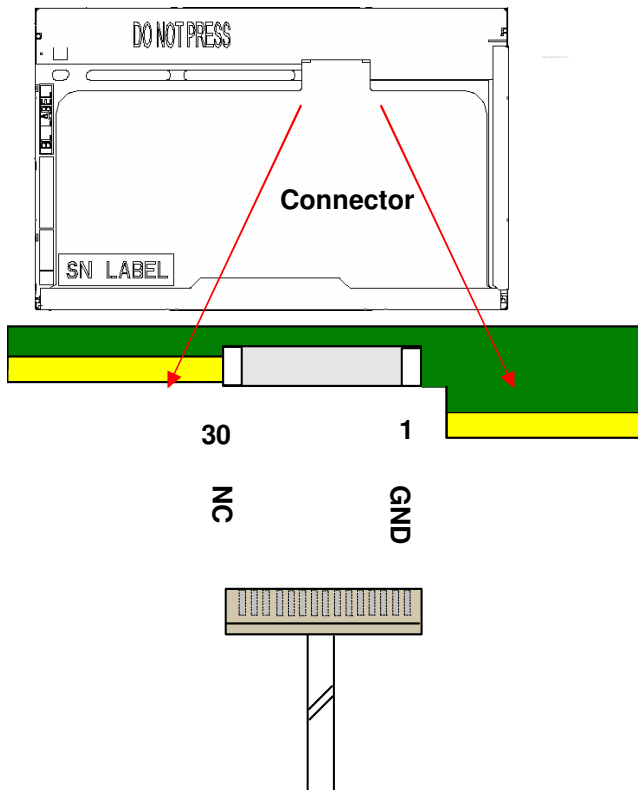

## B154EW07 V2

Note2: Input signals shall be low or High-impedance state when VDD is off.  
internal circuit of LVDS inputs are as following.

The module uses a 100ohm resistor between positive and negative data lines of each receiver input

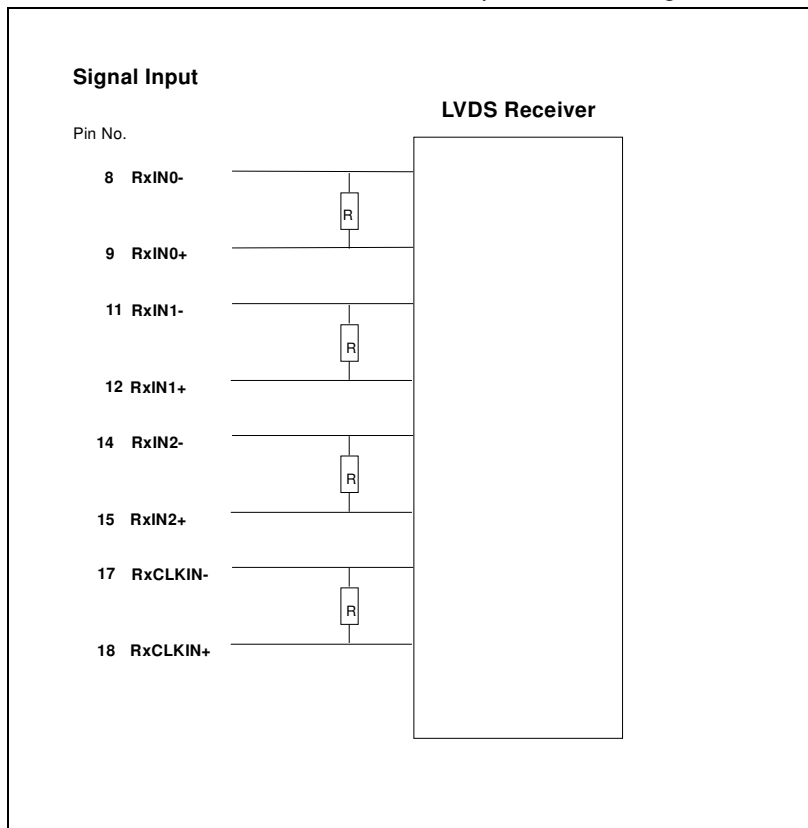



# Product Specification

AU OPTRONICS CORPORATION

B154EW07 V2

## 6.4 Interface Timing

### 6.4.1 Timing Characteristics

Basically, interface timings should match the 1280x800 / 60Hz manufacturing guide line timing.

Parameter	Symbol	Min.	Typ.	Max.	Unit
Frame Rate	-	50	60	-	Hz
Clock frequency	$1/T_{\text{Clock}}$	TBD	68.9	TBD	MHz
Vertical Section	Period	$T_V$	TBD	TBD	TBD
	Active	$T_{VD}$	-	TBD	-
	Blanking	$T_{VB}$	TBD	TBD	TBD
Horizontal Section	Period	$T_H$	TBD	TBD	TBD
	Active	$T_{HD}$	-	TBD	-
	Blanking	$T_{HB}$	TBD	TBD	TBD

Note : DE mode only

## 6.4.2 Timing diagram

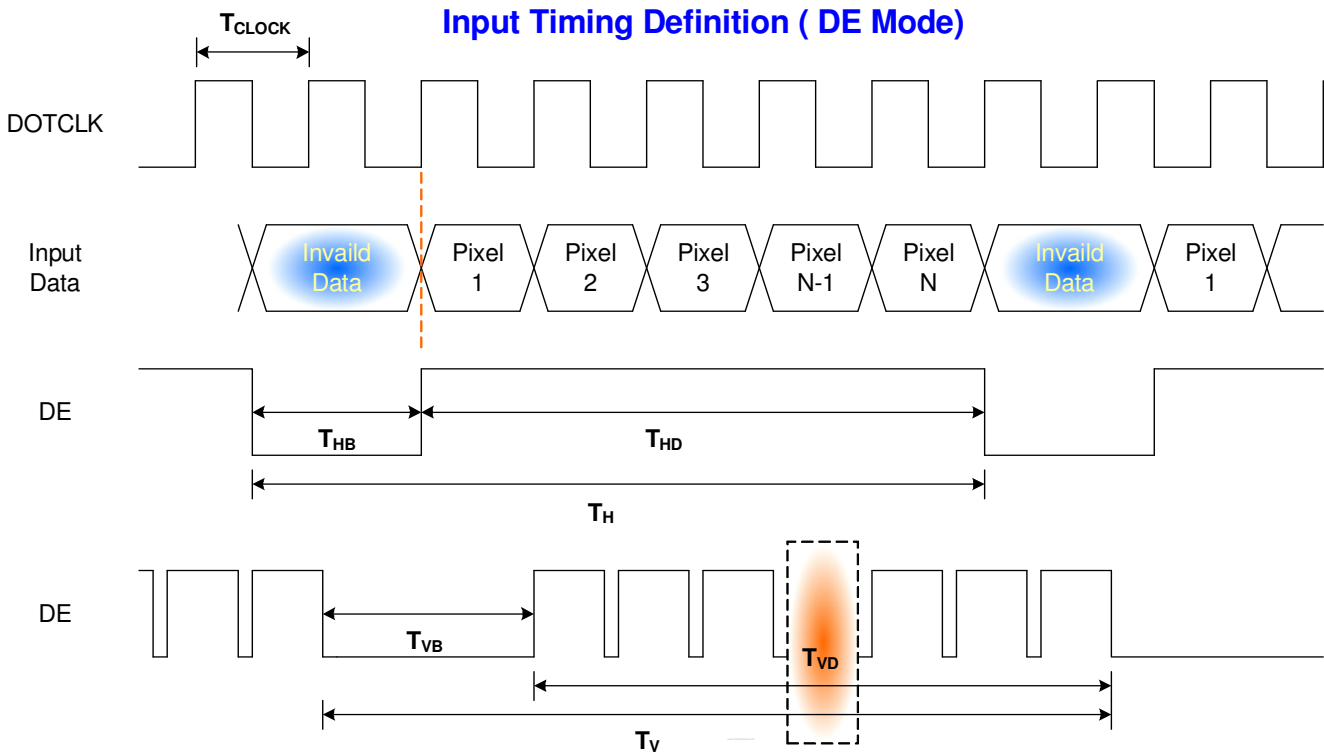

## 6.5 Power ON/OFF Sequence

VDD power and lamp on/off sequence is as follows. Interface signals are also shown in the chart. Signals from any system shall be Hi-Z state or low level when VDD is off.

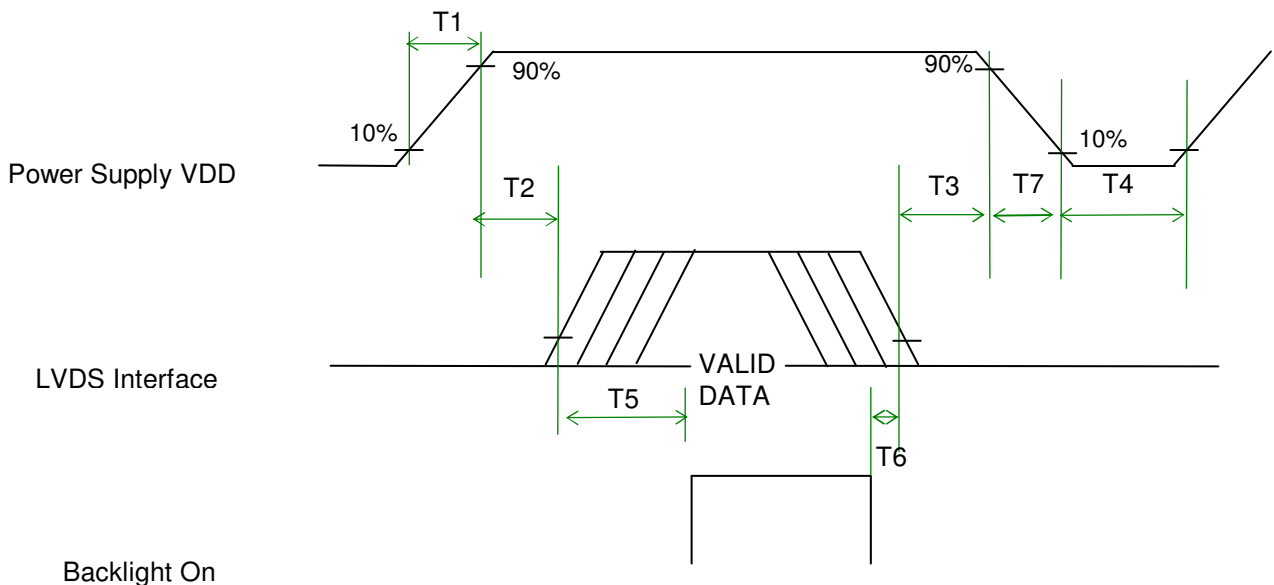



# Product Specification

AU OPTRONICS CORPORATION

B154EW07 V2

## Power Sequence Timing

Parameter	Value			Units
	Min.	Typ.	Max.	
T1	0.5	-	10	(ms)
T2	0	-	50	(ms)
T3	0	-	50	(ms)
T4	400	-	-	(ms)
T5	200	-	-	(ms)
T6	200	-	-	(ms)
T7	0	-	10	(ms)

## 7. Connector Description

Physical interface is described as for the connector on module.

These connectors are capable of accommodating the following signals and will be following components.

### 7.1 TFT LCD Module

Connector Name / Designation	For Signal Connector
Manufacturer	JAE or compatible
Type / Part Number	FI-XB30SL-HF10 or compatible
Mating Housing/Part Number	FI-X30H or compatible

### 7.2 Backlight Unit

Physical interface is described as for the connector on module.

These connectors are capable of accommodating the following signals and will be following components.

Connector Name / Designation	For Lamp Connector
Manufacturer	JST
Type / Part Number	BHSR-02VS-1
Mating Type / Part Number	SM02B-BHSS-1-TB

### 7.3 Signal for Lamp connector

Pin #	Cable color	Signal Name
1	Red	Lamp High Voltage
2	White	Lamp Low Voltage
3	Blue	Lamp High Voltage
4	White (with black tube)	Lamp Low Voltage





# Product Specification

AU OPTRONICS CORPORATION

B154EW07 V2

## 8. Reliability

Items	Required Conditions
Operating Life – High Temp.	Temp.= +50°C, Dynamic. 250 Hours, Room Humidity
Operating Life – Low Temp.	Temp.= 0°C, Dynamic, 250 Hours, Room Humidity
High Temp. Storage Life – Non-Operating	Temp.= +60°C, Non-Operating, 250 Hours, Room Humidity
Low Temp. Storage Life – Non-Operating	Temp.= -20°C, Non-Operating, 250 Hours, Room Humidity
High Temp. & High Humidity Operating Life	Temp.=+40°C,Dynamic, Humidity 95%(Non-Condensing), 250 Hours
Shock – Non-Operating	180g, 2.0 ms, Half Sine Wave
Vibration – Non-Operating	Random vibration, 1.5G zero-to-peak, 10 to 500Hz, 30min. in each of three mutually perpendicular axes
Temp. Cycle – Non-Operating	-20°C to +60°C, Duration at Temp. = 30min, Test Cycles = 50
ESD	Contact : $\pm 6KV$ / operation Air : $\pm 10KV$ / operation



# Product Specification

AU OPTRONICS CORPORATION

B154EW07 V2

**Note 1:** A failure is defined as the appearance of pixel failure on any color layer or the appearance of horizontal or vertical lines, bars etc.

**Note 2:** Low temperature storage “Panel must return to operating temperature range prior to activation.”

**Note 3:** Hi temperature / Humidity test

Max. Wet-bulb temperature is less than 39°C; At glass temperature high than 40 °C.

Temperature and relative humidity range is shown in the figure below.

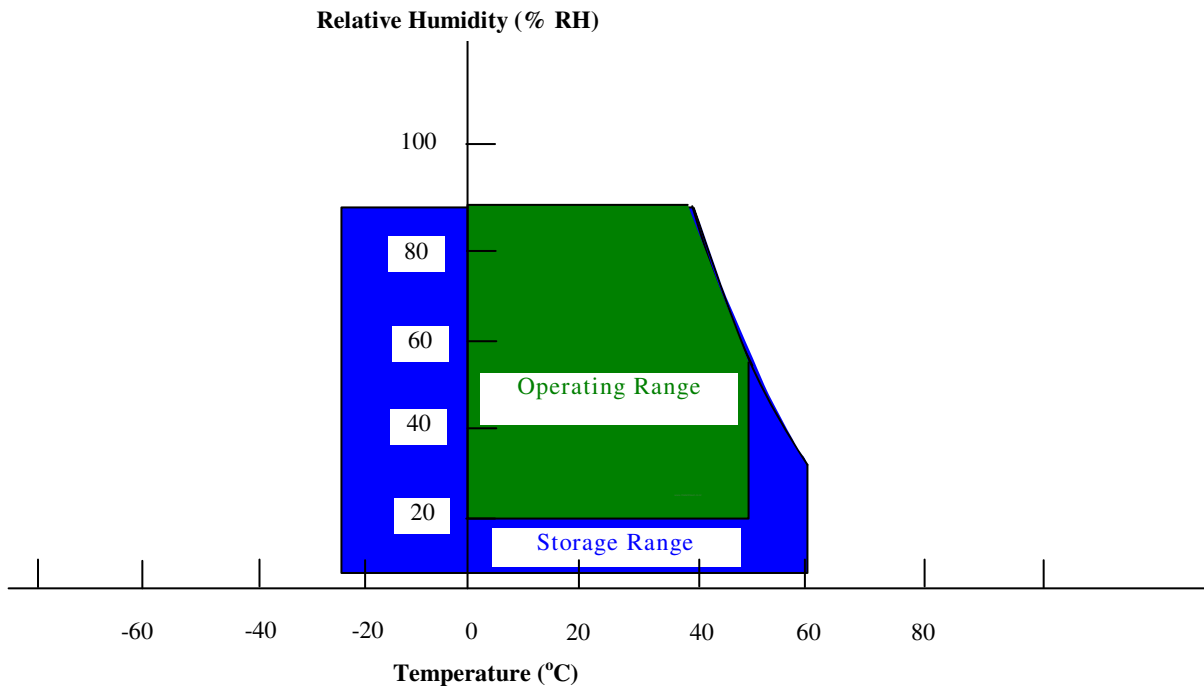



# Product Specification

AU OPTRONICS CORPORATION

B154EW07 V2

## 9. Mechanical Characteristics

### 9.1 LCM Outline Dimension

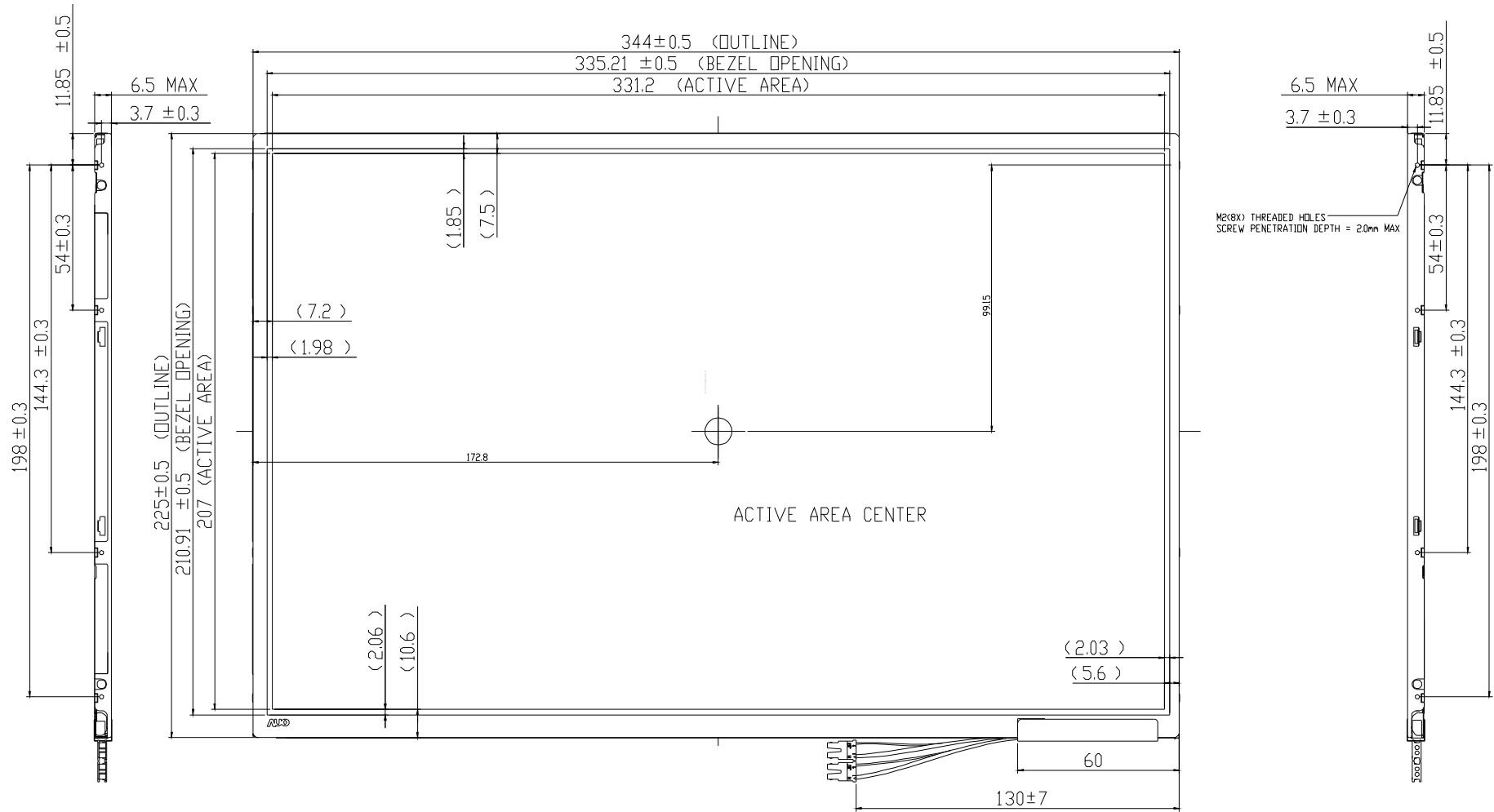



# Product Specification

AU OPTRONICS CORPORATION

B154EW07 V2

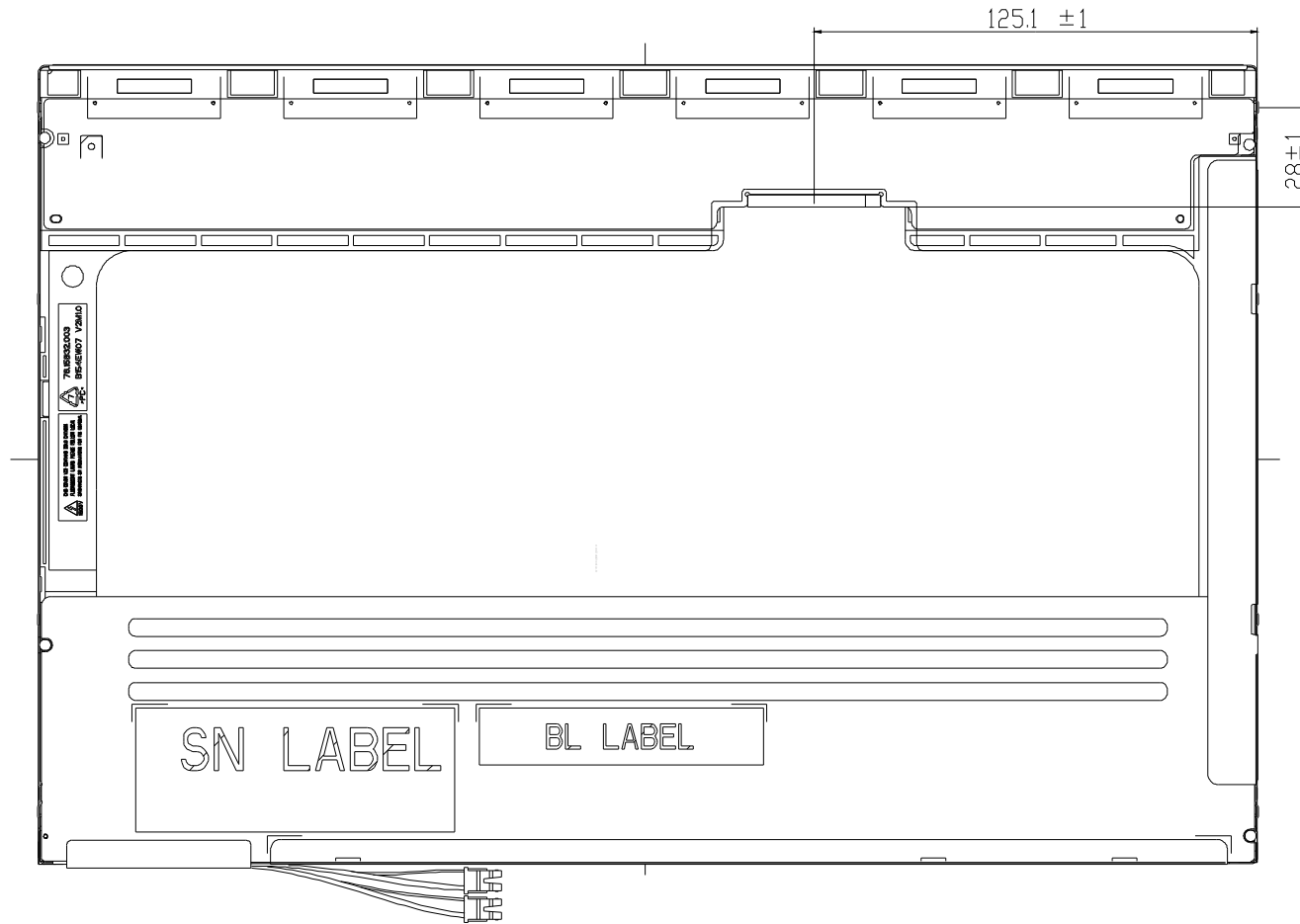

## 9.2 Screw Hole Depth and Center Position

Screw hole minimum depth, from side surface = 2.0 mm (See drawing)

Screw hole center location, from front surface =  $3.7 \pm 0.3$ mm (See drawing)

Screw Torque: Maximum 2.0 kgf-cm

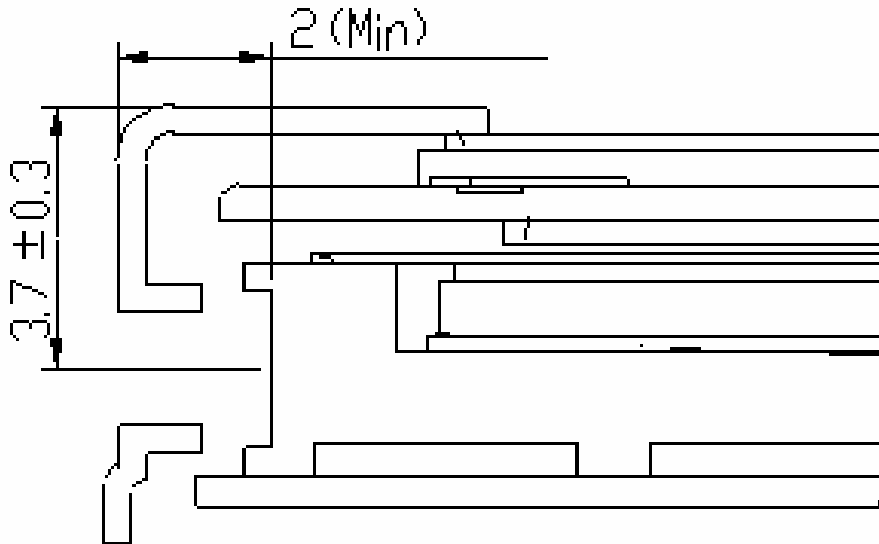



# Product Specification

AU OPTRONICS CORPORATION

B154EW07 V2

## 10. Shipping and Package

### 10.1 Shipping Label Format

 +XXXXXXXXXXXX-XXXXX+	<b>Manufactured</b> MMWW <b>Model No:</b> B154EW07 AU Optronics	V.2 0AXXG	C  JS xxxxxxx		RoHS
<b>H/W: 0A F/W:1</b>					

## 10.2. Carton package

The outside dimension of carton is

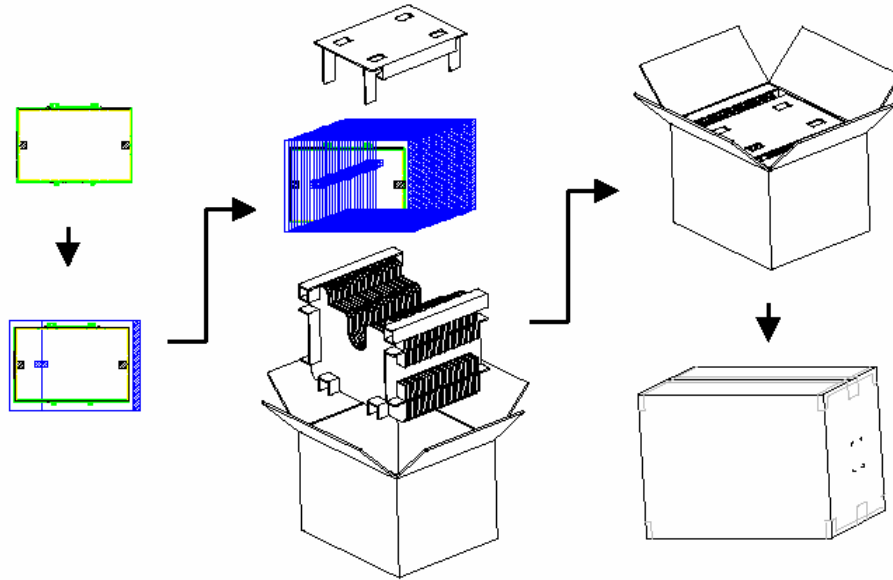

## 11.3 Shipping package of palletizing

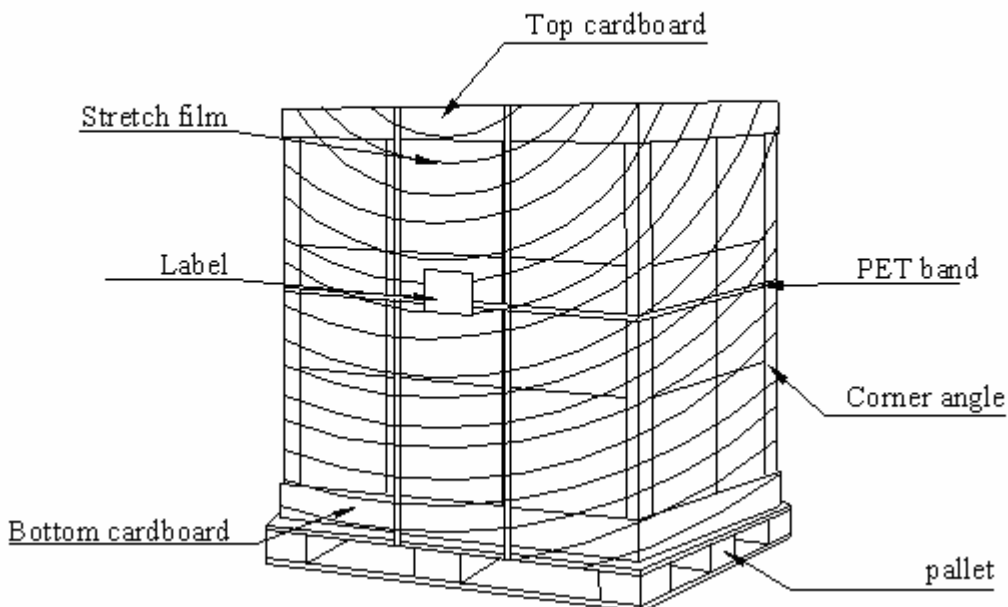



# Product Specification

AU OPTRONICS CORPORATION

B154EW07 V2

## 11. Appendix: EDID description

Address	FUNCTION	Value	Value	Value	Note
HEX		HEX	BIN	DEC	
00	Header	00	00000000	0	
01		FF	11111111	255	
02		FF	11111111	255	
03		FF	11111111	255	
04		FF	11111111	255	
05		FF	11111111	255	
06		FF	11111111	255	
07		00	00000000	0	
08	EISA Manuf. Code LSB	06	00000110	6	
09	Compressed ASCII	AF	10101111	175	
0A	Product Code	74	01110100	116	
0B	hex, LSB first	72	01110010	114	
0C	32-bit ser #	00	00000000	0	
0D		00	00000000	0	
0E		00	00000000	0	
0F		00	00000000	0	
10	Week of manufacture	01	00000001	1	
11	Year of manufacture	10	00010000	16	
12	EDID Structure Ver.	01	00000001	1	
13	EDID revision #	03	00000011	3	
14	<b>Video input def. (digital I/P, non-TMDS, CRGB)</b>	80	10000000	128	
15	<b>Max H image size (rounded to cm)</b>	21	00100001	33	
16	<b>Max V image size (rounded to cm)</b>	15	00010101	21	
17	<b>Display Gamma (=gamma*100)-100</b>	78	01111000	120	
18	<b>Feature support (no DPMS, Active OFF, RGB, tmg Blk#1)</b>	0A	00001010	10	
19	Red/green low bits (Lower 2:2:2:2 bits)	FE	11111110	254	
1A	Blue/white low bits (Lower 2:2:2:2 bits)	25	00100101	37	
1B	Red x (Upper 8 bits)	A8	10101000	168	
1C	Red y/ highER 8 bits	54	01010100	84	
1D	Green x	38	00111000	56	
1E	Green y	AD	10101101	173	
1F	Blue x	26	00100110	38	
20	Blue y	10	00010000	16	
21	White x	50	01010000	80	
22	White y	54	01010100	84	





# Product Specification

AU OPTRONICS CORPORATION

B154EW07 V2

23	Established timing 1	00	00000000	0	
24	Established timing 2	00	00000000	0	
25	Established timing 3	00	00000000	0	
26	Standard timing #1	01	00000001	1	
27		01	00000001	1	
28	Standard timing #2	01	00000001	1	
29		01	00000001	1	
2A	Standard timing #3	01	00000001	1	
2B		01	00000001	1	
2C	Standard timing #4	01	00000001	1	
2D		01	00000001	1	
2E	Standard timing #5	01	00000001	1	
2F		01	00000001	1	
30	Standard timing #6	01	00000001	1	
31		01	00000001	1	
32	Standard timing #7	01	00000001	1	
33		01	00000001	1	
34	Standard timing #8	01	00000001	1	
35		01	00000001	1	
36	Pixel Clock/10000 LSB	C7	11000111	199	
37	Pixel Clock/10000 USB	1B	00011011	27	
38	Horz active Lower 8bits	00	00000000	0	
39	Horz blanking Lower 8bits	A0	10100000	160	
3A	HorzAct:HorzBlnk Upper 4:4 bits	50	01010000	80	
3B	Vertical Active Lower 8bits	20	00100000	32	
3C	Vertical Blanking Lower 8bits	17	00010111	23	
3D	Vert Act : Vertical Blanking (upper 4:4 bit)	30	00110000	48	
3E	HorzSync. Offset	30	00110000	48	
3F	HorzSync.Width	20	00100000	32	
40	VertSync.Offset : VertSync.Width	36	00110110	54	
41	Horz&Vert Sync Offset/Width Upper 2bits	00	00000000	0	
42	Horizontal Image Size Lower 8bits	4B	01001011	75	
43	Vertical Image Size Lower 8bits	CF	11001111	207	
44	Horizontal & Vertical Image Size (upper 4:4 bits)	10	00010000	16	
45	Horizontal Border (zero for internal LCD)	00	00000000	0	
46	Vertical Border (zero for internal LCD)	00	00000000	0	
47	Signal (non-intr, norm, no stereo, sep sync, neg pol)	18	00011000	24	
48	Detailed timing/monitor	00	00000000	0	



# Product Specification

AU OPTRONICS CORPORATION

B154EW07 V2

49	descriptor #2	00	00000000	0	
4A		00	00000000	0	
4B		0F	00001111	15	
4C		00	00000000	0	
4D		00	00000000	0	
4E		00	00000000	0	
4F		00	00000000	0	
50		00	00000000	0	
51		00	00000000	0	
52		00	00000000	0	
53		00	00000000	0	
54		00	00000000	0	
55		00	00000000	0	
56		00	00000000	0	
57		00	00000000	0	
58		00	00000000	0	
59		20	00100000	32	
5A	Detailed timing/monitor	00	00000000	0	
5B	descriptor #3	00	00000000	0	
5C		00	00000000	0	
5D		FE	11111110	254	
5E		00	00000000	0	
5F	Manufacture	41	01000001	65	A
60	Manufacture	55	01010101	85	U
61	Manufacture	4F	01001111	79	O
62		0A	00001010	10	
63		20	00100000	32	
64		20	00100000	32	
65		20	00100000	32	
66		20	00100000	32	
67		20	00100000	32	
68		20	00100000	32	
69		20	00100000	32	
6A		20	00100000	32	
6B		20	00100000	32	
6C	Detailed timing/monitor	00	00000000	0	
6D	descriptor #4	00	00000000	0	
6E		00	00000000	0	
6F		FE	11111110	254	



# Product Specification

AU OPTRONICS CORPORATION

B154EW07 V2

70		00	00000000	0	
71	Manufacture P/N	42	01000010	66	B
72	Manufacture P/N	31	00110001	49	1
73	Manufacture P/N	35	00110101	53	5
74	Manufacture P/N	34	00110100	52	4
75	Manufacture P/N	45	01000101	69	E
76	Manufacture P/N	57	01010111	87	W
77	Manufacture P/N	30	00110000	48	0
78	Manufacture P/N	37	00110111	55	7
79	Manufacture P/N	20	00100000	32	
7A	Manufacture P/N	56	01010110	86	V
7B	Manufacture P/N	32	00110010	50	2
7C		20	00100000	32	
7D		0A	00001010	10	
7E	Extension Flag	00	00000000	0	
7F	Checksum	44	01000100	68	