



# Product Specification

AU OPTRONICS CORPORATION

- (✓) Preliminary Specifications
- ( ) Final Specifications

<b>Module</b>	<b>15.6" FHD 16:9 Color TFT-LCD with LED Backlight design</b>
<b>Model Name</b>	B156HAN01.0 (H/W: 0A)
<b>Note</b> (  )	<b>LED Backlight with driving circuit design</b>

<b>Customer</b>	<b>Date</b>
<b>Checked &amp; Approved by</b>	<b>Date</b>
<p>Note: This Specification is subject to change without notice.</p>	

<b>Approved by</b>	<b>Date</b>
<b>Prepared by</b>	<b>Date</b>
<u>Tina GT Lin</u>	<u>10/25/2012</u>
<b>DMPBU Marketing Division</b> <b>AU Optronics corporation</b>	



## Contents

<b>1. Handling Precautions</b> .....	<b>4</b>
<b>2. General Description</b> .....	<b>5</b>
2.1 General Specification .....	5
2.2 Optical Characteristics .....	6
<b>3. Functional Block Diagram</b> .....	<b>11</b>
<b>4. Absolute Maximum Ratings</b> .....	<b>12</b>
4.1 Absolute Ratings of TFT LCD Module.....	12
4.2 Absolute Ratings of Environment .....	12
<b>5. Electrical Characteristics</b> .....	<b>13</b>
5.1 TFT LCD Module .....	13
5.2 Backlight Unit .....	15
<b>6. Signal Interface Characteristic</b> .....	<b>16</b>
6.1 Pixel Format Image .....	16
6.2 Integration Interface Requirement .....	17
6.3 Interface Timing .....	19
6.4 Power On Sequence .....	20
<b>7. Panel Reliability Test</b> .....	<b>21</b>
7.1 Vibration Test.....	21
7.2 Shock Test .....	21
7.3 Reliability Test .....	21
<b>8. Mechanical Characteristics</b> .....	<b>22</b>
8.1 LCM Outline Dimension .....	22
<b>9. Shipping and Package</b> .....	<b>24</b>
9.1 Shipping Label Format .....	24
9.2 Carton Package .....	25
9.3 Shipping Package of Palletizing Sequence.....	25
<b>10. Appendix: EDID Description</b> .....	<b>26</b>



## 1. Handling Precautions

- 1) Since front polarizer is easily damaged, pay attention not to scratch it.
- 2) Be sure to turn off power supply when inserting or disconnecting from input connector.
- 3) Wipe off water drop immediately. Long contact with water may cause discoloration or spots.
- 4) When the panel surface is soiled, wipe it with absorbent cotton or other soft cloth.
- 5) Since the panel is made of glass, it may break or crack if dropped or bumped on hard surface.
- 6) Since CMOS LSI is used in this module, take care of static electricity and insure human earth when handling.
- 7) Do not open nor modify the Module Assembly.
- 8) Do not press the reflector sheet at the back of the module to any directions.
- 9) At the insertion or removal of the Signal Interface Connector, be sure not to rotate nor tilt the Interface Connector of the TFT Module.
- 11) After installation of the TFT Module into an enclosure (Notebook PC Bezel, for example), do not twist nor bend the TFT Module even momentarily. At designing the enclosure, it should be taken into consideration that no bending/twisting forces are applied to the TFT Module from outside. Otherwise the TFT Module may be damaged.
- 12) Small amount of materials having no flammability grade is used in the LCD module. The LCD module should be supplied by power complied with requirements of Limited Power Source (IEC60950 or UL1950), or be applied exemption.
- 13) Disconnecting power supply before handling LCD modules, it can prevent electric shock, DO NOT TOUCH the electrode parts, cables, connectors and LED circuit part of TFT module that a LED light bar build in as a light source of back light unit. It can prevent electrostatic breakdown.



## 2. General Description

B156HAN01.0 is a Color Active Matrix Liquid Crystal Display composed of a TFT LCD panel, a driver circuit, and LED backlight system. The screen format is intended to support the 16:9 FHD, 1920(H) x1080(V) screen and 262k colors (RGB 6-bits data driver) with LED backlight driving circuit. All input signals are LVDS interface compatible.

B156HAN01.0 is designed for a display unit of notebook style personal computer and industrial machine.

### 2.1 General Specification

The following items are characteristics summary on the table at 25 °C condition:

Items	Unit	Specifications			
Screen Diagonal	[mm]	394.9			
Active Area	[mm]	344.16 x 193.59			
Pixels H x V		1920 x 3(RGB) x 1080			
Pixel Pitch	[mm]	0.17925 x 0.17925			
Pixel Format		R.G.B. Vertical Stripe			
Display Mode		Normally Black			
White Luminance (I <sub>LED</sub> = 20mA) (Note: I <sub>LED</sub> is LED current)	[cd/m <sup>2</sup> ]	300 typ. (5 points average) 255 min. (5 points average )			
Luminance Uniformity		1.25 max. (5 points)			
Contrast Ratio		800 typ			
Response Time	[ms]	25 typ			
Nominal Input Voltage VDD	[Volt]	+3.3 typ.			
Power Consumption	[Watt]	5.4max. (Include Logic and Blu power)			
Weight	[Grams]	380 max.			
Physical Size Include bracket	[mm]		Min.	Typ.	Max.
		Length	359.0	359.5	360.0
		Width	223.3	223.8	224.3
		Thickness	---	---	3.2
Electrical Interface		2 channel LVDS			
Glass Thickness	[mm]	0.3			
Surface Treatment		Glare			
Support Color		262K colors ( RGB 6-bit )			
Temperature Range					
Operating	[°C]	0 to +50			
Storage (Non-Operating)	[°C]	-20 to +60			
RoHS Compliance		RoHS Compliance			

Note: Contrast ratio measured in the center of screen



# Product Specification

AU OPTRONICS CORPORATION

## 2.2 Optical Characteristics

The optical characteristics are measured under stable conditions at 25°C (Room Temperature) :

Item	Symbol	Conditions	Min.	Typ.	Max.	Unit	Note		
White Luminance ILED=20mA		5 points average	255	300	---	cd/m <sup>2</sup>	1, 4, 5.		
Viewing Angle	$\theta_R$	Horizontal (Right) CR = 10 (Left)	80	85	---	degree	4, 9		
	$\theta_L$		80	85	---				
	$\psi_H$	Vertical (Upper) CR = 10 (Lower)	80	85	---				
	$\psi_L$		80	85	---				
Luminance Uniformity	$\delta_{5P}$	5 Points	---	---	1.25		1, 3, 4		
Luminance Uniformity	$\delta_{13P}$	13 Points	---	---	1.60		2, 3, 4		
Contrast Ratio	CR			800	-		4, 6		
Cross talk	%		---	---	4		4, 7		
Response Time	$T_{RT}$	Rising + Falling	---	25	---	msec	4, 8		
Color / Chromaticity Coordinates	Red	Rx	CIE 1931	TBD	TBD	TBD	4		
		Ry		TBD	TBD	TBD			
	Green	Gx		TBD	TBD	TBD			
		Gy		TBD	TBD	TBD			
	Blue	Bx		TBD	TBD	TBD			
		By		TBD	TBD	TBD			
	White	Wx		0.283	0.313	0.343			
		Wy		0.299	0.329	0.359			
	NTSC	%			-	72		-	

Note: Contrast ratio measured in the center of screen

**Note 1:** 5 points position (Ref: Active area)

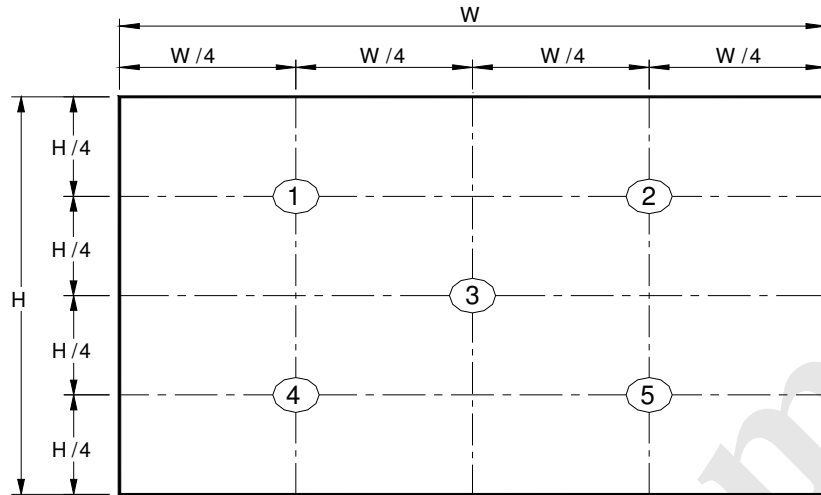

**Note 2:** 13 points position (Ref: Active area)

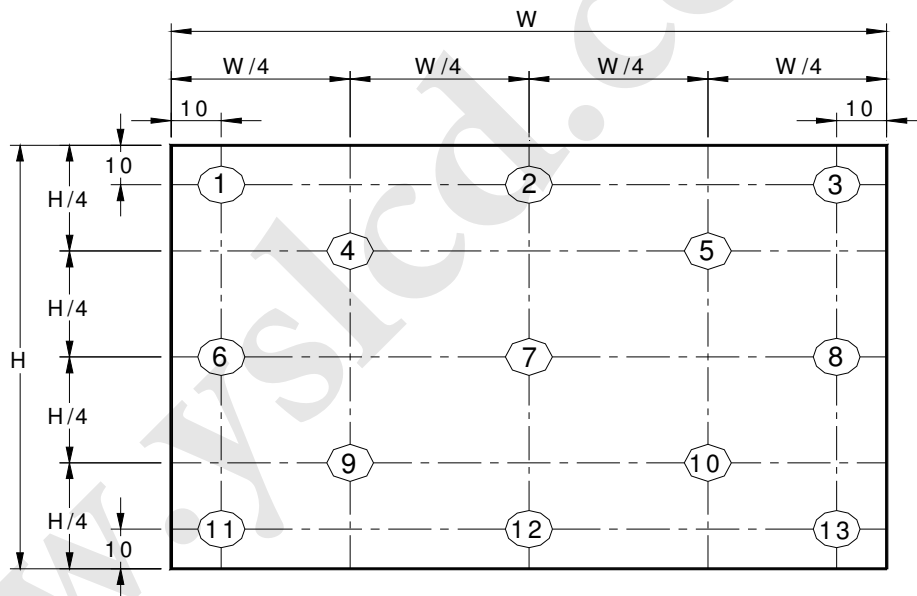

**Note 3:** The luminance uniformity of 5 or 13 points is defined by dividing the maximum luminance values by the minimum test point luminance

$$\delta_{w5} = \frac{\text{Maximum Brightness of five points}}{\text{Minimum Brightness of five points}}$$

$$\delta_{w13} = \frac{\text{Maximum Brightness of thirteen points}}{\text{Minimum Brightness of thirteen points}}$$

**Note 4:** Measurement method

The LCD module should be stabilized at given temperature for 30 minutes to avoid abrupt temperature change during measuring. In order to stabilize the luminance, the measurement should be executed after lighting Backlight for 30 minutes in a stable, windless and dark room, and it should be measured in the center of screen.

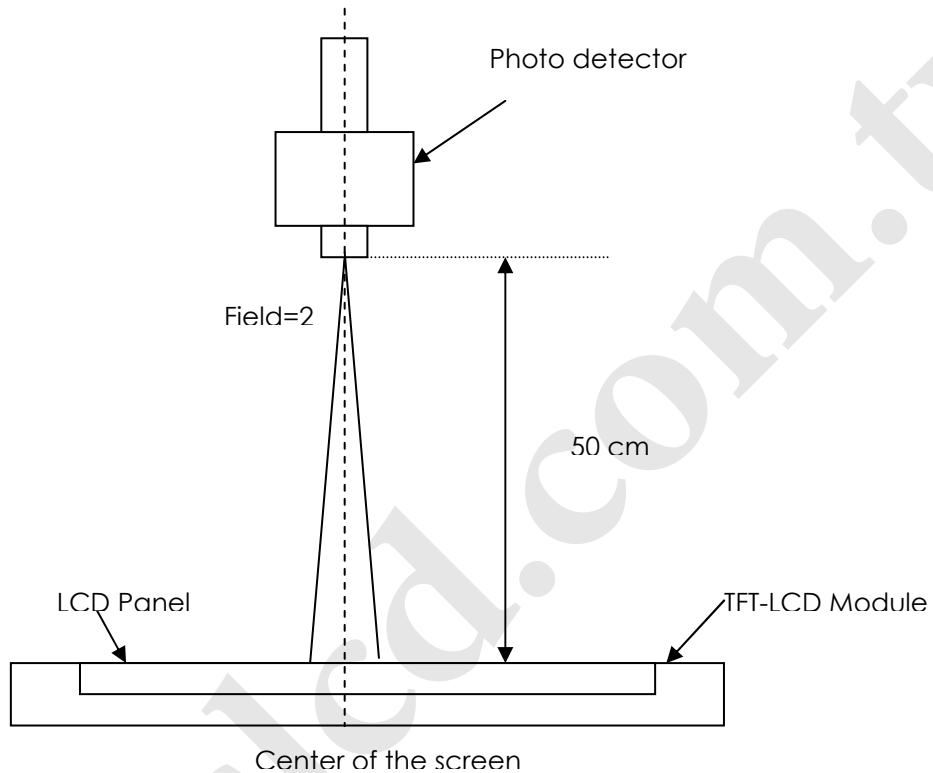

**Note 5 :** Definition of Average Luminance of White ( $Y_L$ ):

Measure the luminance of gray level 63 at 5 points ·  $Y_L = [L(1) + L(2) + L(3) + L(4) + L(5)] / 5$

$L(x)$  is corresponding to the luminance of the point X at Figure in Note (1).

**Note 6 :** Definition of contrast ratio:

Contrast ratio is calculated with the following formula.

$$\text{Contrast ratio (CR)} = \frac{\text{Brightness on the "White" state}}{\text{Brightness on the "Black" state}}$$

**Note 7 :** Definition of Cross Talk (CT)

$$CT = |Y_B - Y_A| / Y_A \times 100 (\%)$$

Where

$Y_A$  = Luminance of measured location without gray level 0 pattern (cd/m<sup>2</sup>)

$Y_B$  = Luminance of measured location with gray level 0 pattern (cd/m<sup>2</sup>)



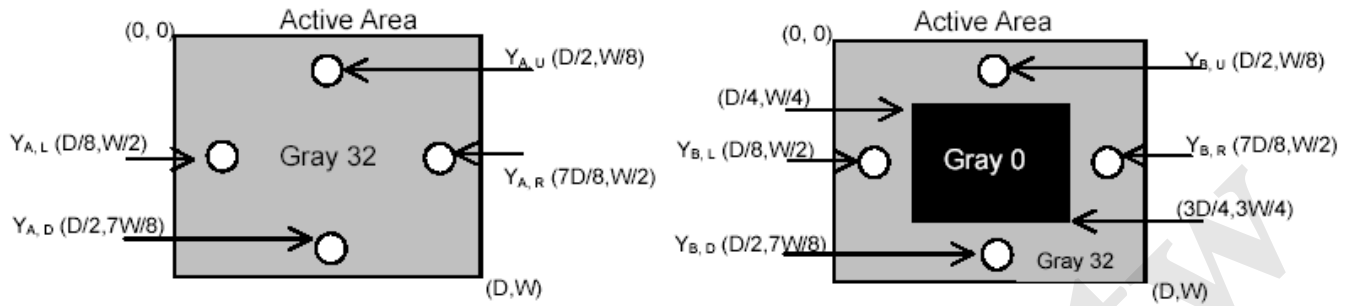

**Note 8:** Definition of response time:

The output signals of BM-7 or equivalent are measured when the input signals are changed from "Black" to "White" (falling time) and from "White" to "Black" (rising time), respectively. The response time interval between the 10% and 90% of amplitudes. Refer to figure as below.

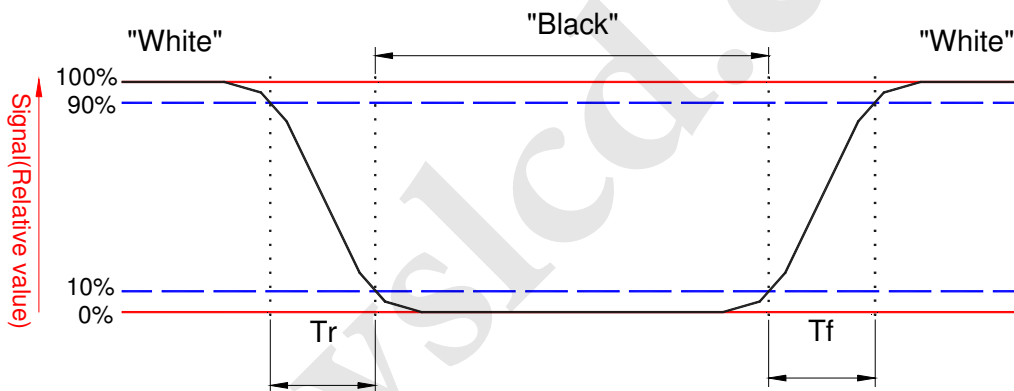

**Note 9.** Definition of viewing angle

Viewing angle is the measurement of contrast ratio  $\geq 10$ , at the screen center, over a  $180^\circ$  horizontal and  $180^\circ$  vertical range (off-normal viewing angles). The  $180^\circ$  viewing angle range is broken down as follows;  $90^\circ$  ( $\theta$ ) horizontal left and right and  $90^\circ$  ( $\phi$ ) vertical, high (up) and low (down). The measurement direction is typically perpendicular to the display surface with the screen rotated about its center to develop the desired measurement viewing angle.

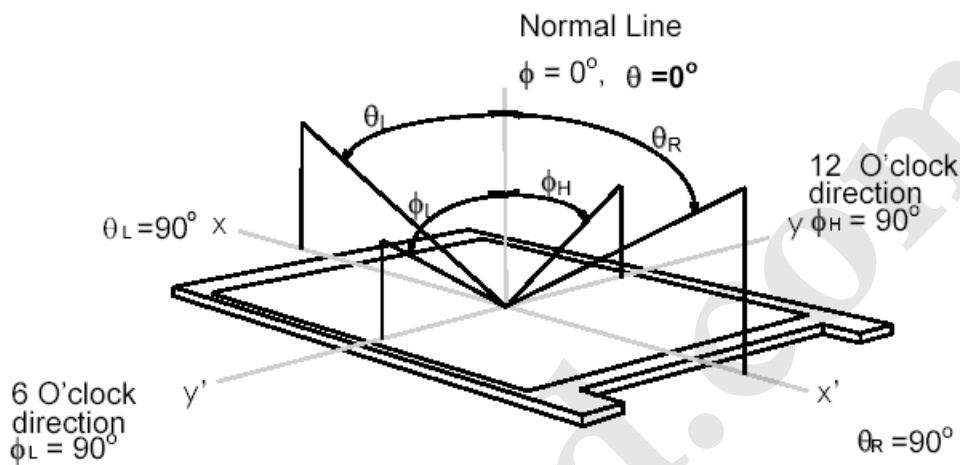

### 3. Functional Block Diagram

The following diagram shows the functional block of the 15.6 inches wide Color TFT/LCD 40 Pin one channel Module

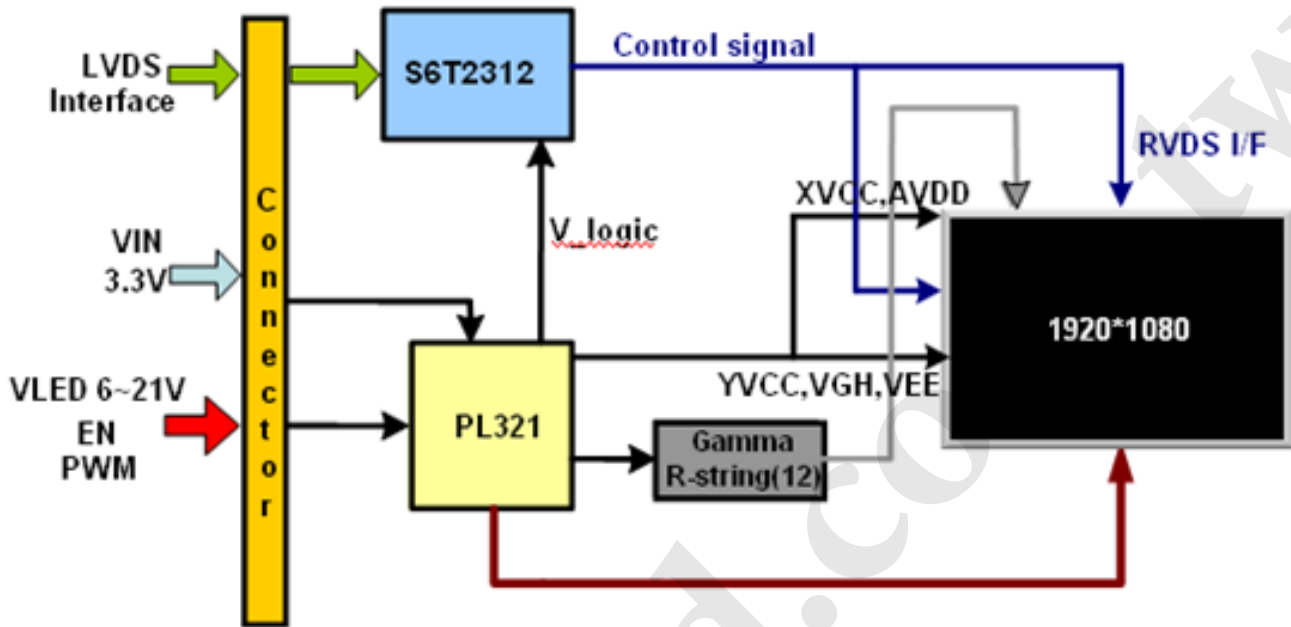

## 4. Absolute Maximum Ratings

An absolute maximum rating of the module is as following:

### 4.1 Absolute Ratings of TFT LCD Module

Item	Symbol	Min	Max	Unit	Conditions
Logic/LCD Drive	Vin	-0.3	+4.0	[Volt]	Note 1,2

### 4.2 Absolute Ratings of Environment

Item	Symbol	Min	Max	Unit	Conditions
Operating	TOP	0	+50	[°C]	Note 4
Operation Humidity	HOP	5	95	[%RH]	Note 4
Storage Temperature	TST	-20	+60	[°C]	Note 4
Storage Humidity	HST	5	95	[%RH]	Note 4

Note 1: At Ta (25°C )

Note 2: Permanent damage to the device may occur if exceed maximum values

Note 3: LED specification refer to section 5.2

Note 4: For quality performance, please refer to AUO IIS (Incoming Inspection Standard).

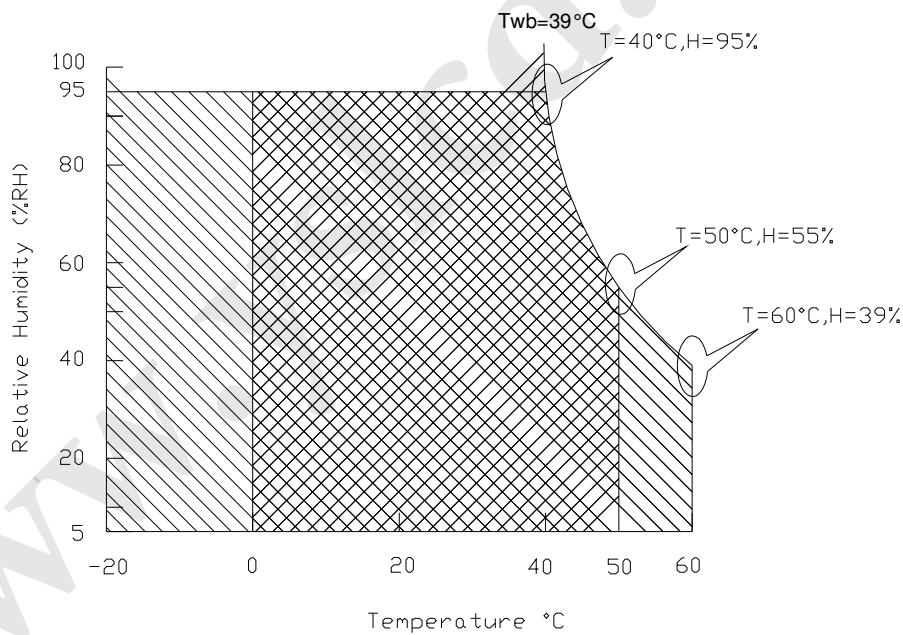

Operating Range 

Storage Range  + 

## 5. Electrical Characteristics

### 5.1 TFT LCD Module

#### 5.1.1 Power Specification

Input power specifications are as follows;

The power specification are measured under 25°C and frame frequency under 60Hz

Symble	Parameter	Min	Typ	Max	Units	Note
VDD	Logic/LCD Drive Voltage	3.0	3.3	3.6	[Volt]	
PDD	VDD Power	-	-	1.1	[Watt]	Note 1/2
IDD	IDD Current	-	-	367	[mA]	Note 1/2
IRush	Inrush Current	-	-	2000	[mA]	Note 2
VDDrp	Allowable Logic/LCD Drive Ripple Voltage	-	-	100	[mV] p-p	

Note 1 : Maximum Measurement Condition : Black Pattern at 3.3V driving voltage. ( $P_{max}=V_{3.3} \times I_{black}$ )

Typical Measurement Condition : Mosaic Pattern

Note 2 : Measure Condition

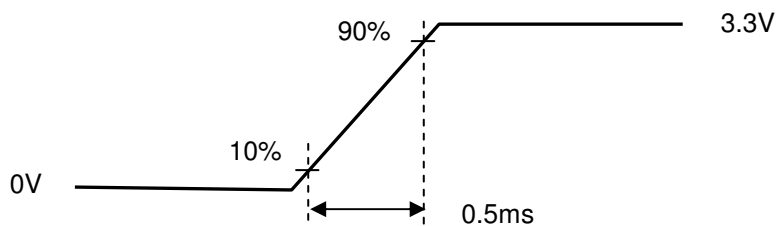
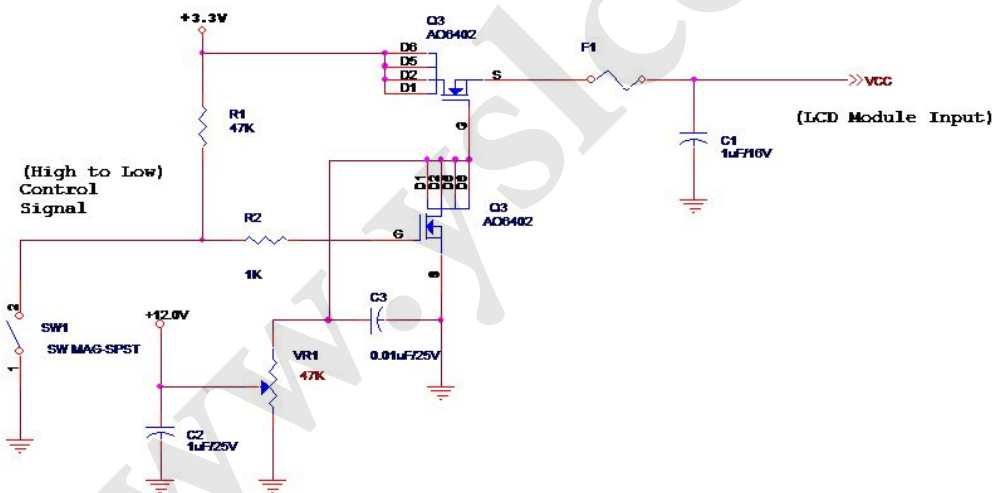

## 5.1.2 Signal Electrical Characteristics

Input signals shall be low or High-impedance state when VDD is off.

Signal electrical characteristics are as follows;

Parameter	Condition	Min	Max	Unit
$V_{TH}$	Differential Input High Threshold ( $V_{cm}=+1.2V$ )	-	100	[mV]
$V_{TL}$	Differential Input Low Threshold ( $V_{cm}=+1.2V$ )	-100	-	[mV]
$ V_{ID} $	Differential Input Voltage	100	600	[mV]
$V_{CM}$	Differential Input Common Mode Voltage	1.125	1.375	[V]

Note: LVDS Signal Waveform

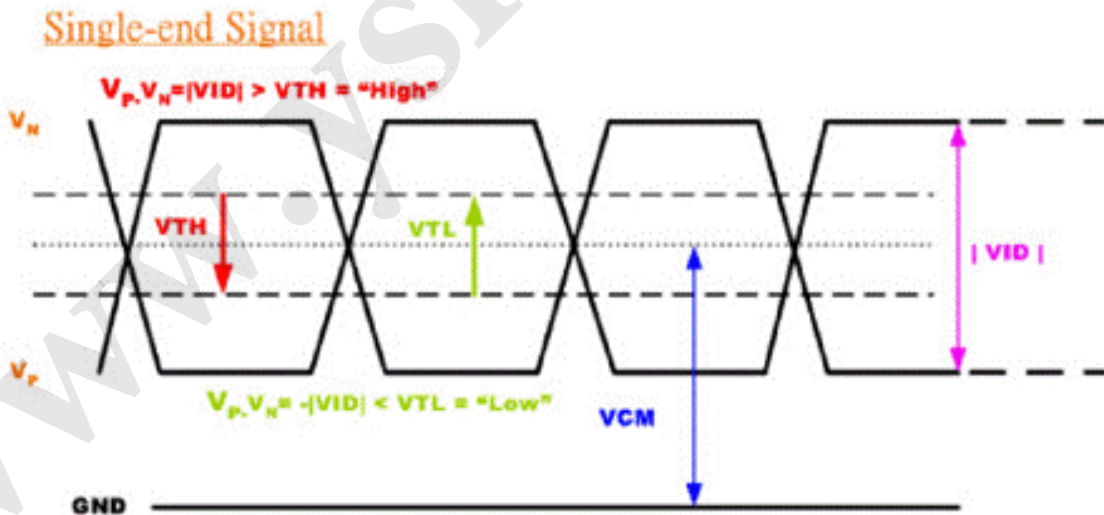

## 5.2 Backlight Unit

### 5.2.1 LED characteristics

Parameter	Symbol	Min	Typ	Max	Units	Condition
Backlight Power Consumption	PLED	-	-	4.3	[Watt]	(Ta=25°C), Note 1 Vin =12V
LED Life-Time	N/A	15,000	-	-	Hour	(Ta=25°C), Note 2 If=20mA

**Note 1:** Calculator value for reference  $P_{LED} = V_F$  (Normal Distribution) \*  $I_F$  (Normal Distribution) / Efficiency

**Note 2:** The LED life-time define as the estimated time to 50% degradation of initial luminous.

### 5.3.2 Backlight input signal characteristics

Parameter	Symbol	Min	Typ	Max	Units	Remark
LED Power Supply	VLED	6	12.0	21.0	[Volt]	Define as Connector Interface (Ta=25°C)
PWM Logic Input High Level	VPWM_EN	2.5	-	5.5	[Volt]	
PWM Logic Input Low Level		-	-	0.5	[Volt]	
PWM Input Frequency	FPWM Duty	200	1K	10K	Hz	
PWM Duty Ratio		5	--	100	%	

## 6. Signal Interface Characteristic

### 6.1 Pixel Format Image

Following figure shows the relationship of the input signals and LCD pixel format.

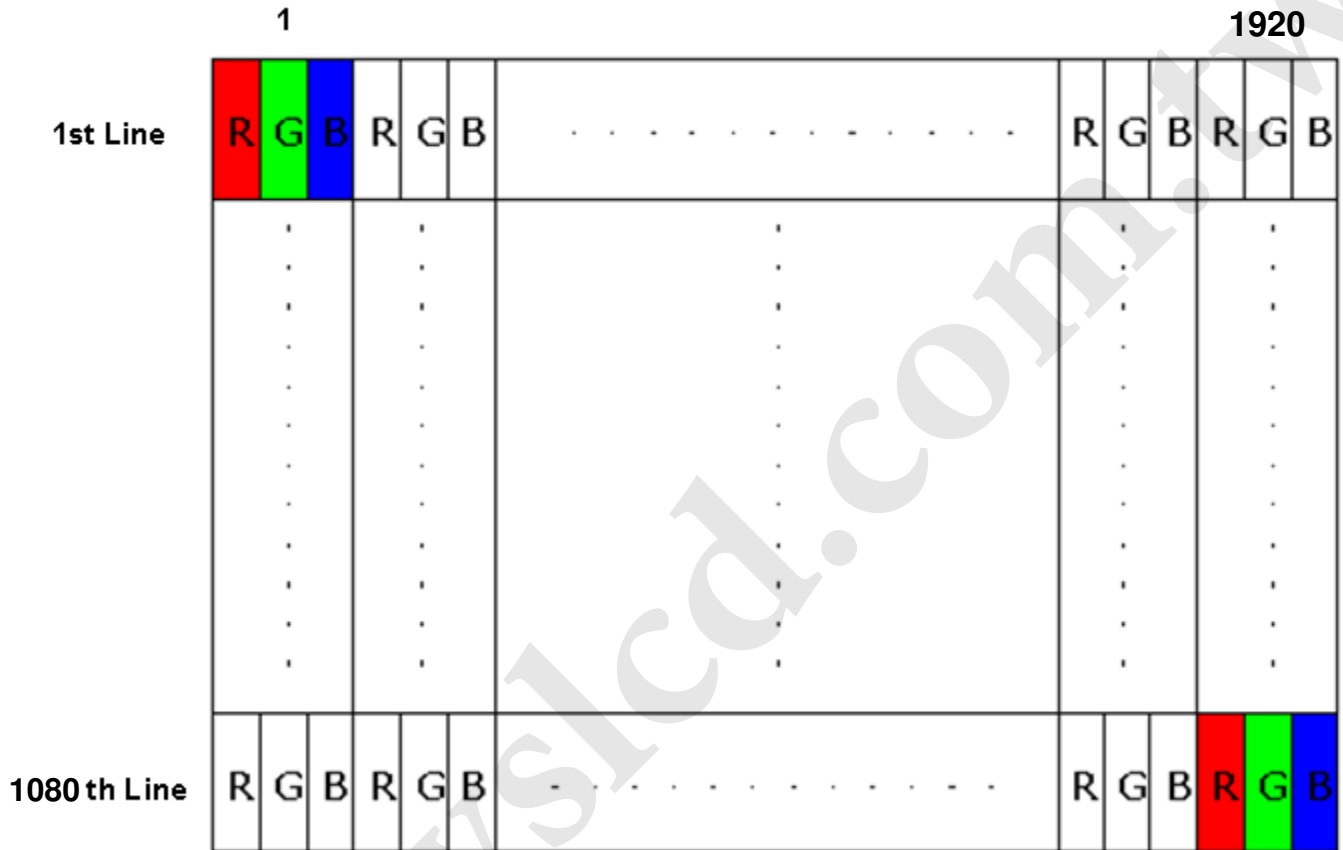



## 6.2 Integration Interface Requirement

### 6.2.1 Connector Description

Physical interface is described as for the connector on module.

These connectors are capable of accommodating the following signals and will be following components.

Connector Name / Designation	For Signal Connector
Manufacturer	IPEX or Compatible
Type / Part Number	I-PEX 20455-040E-12 or Compatible
Mating Housing/Part Number	I-PEX 20453-040T or Compatible

### 6.2.2 Pin Assignment

LVDS is a differential signal technology for LCD interface and high speed data transfer device.

Pin	Signal	Description
1	NC	No connection (Reserved for supplier)
2	AVDD	PowerSupply,3.3V(typical)
3	AVDD	PowerSupply,3.3V(typical)
4	DVDD	DDC 3.3Vpower
5	NC	No connection
6	SCL	DDCClock
7	SDA	DDCData
8	Odd_Rin0-	-LVDSdifferential data input(R0-R5,G0)
9	Odd_Rin0+	+LVDSdifferential data input(R0-R5,G0)
10	GND	Ground
11	Odd_Rin1-	-LVDSdifferential data input(G1-G5,B0-B1)
12	Odd_Rin1+	+LVDSdifferential data input(G1-G5,B0-B1)
13	GND	Ground
14	Odd_Rin2-	-LVDSdifferential data input(B2-B5,HS,VS,DE)
15	Odd_Rin2+	+LVDSdifferential data input(B2-B5,HS,VS,DE)
16	GND	Ground
17	Odd_ClkIN-	-LVDSdifferential clock input
18	Odd_ClkIN+	+LVDSdifferential clock input
19	GND	Ground-Shield
20	Even_Rin0-	-LVDSdifferential data input(R0-R5,G0)
21	Even_Rin0+	+LVDSdifferential data input(R0-R5,G0)

22	GND	Ground
23	Even_Rin1-	-LVDSdifferential data input(G1-G5,B0-B1)
24	Even_Rin1+	+LVDSdifferential data input(G1-G5,B0-B1)
25	GND	Ground
26	Even_Rin2-	-LVDSdifferential data input(B2-B5,HS,VS,DE)
27	Even_Rin2+	+LVDSdifferential data input(B2-B5,HS,VS,DE)
28	GND	Ground
29	Even_ClkIN-	-LVDSdifferential clock input
30	Even_ClkIN+	+LVDSdifferential clock input
31	GND	Ground-Shield
32	VLED_GND	LED Ground
33	VLED_GND	LED Ground
34	NC	No connection (Reserved for supplier)
35	BLIM	PWM for luminance control
36	LED_Enable/NC	BL On/Off
37	NC	No connection (Reserved for supplier)
38	VLED	LED Power Supply
39	VLED	LED Power Supply
40	VLED	LED Power Supply

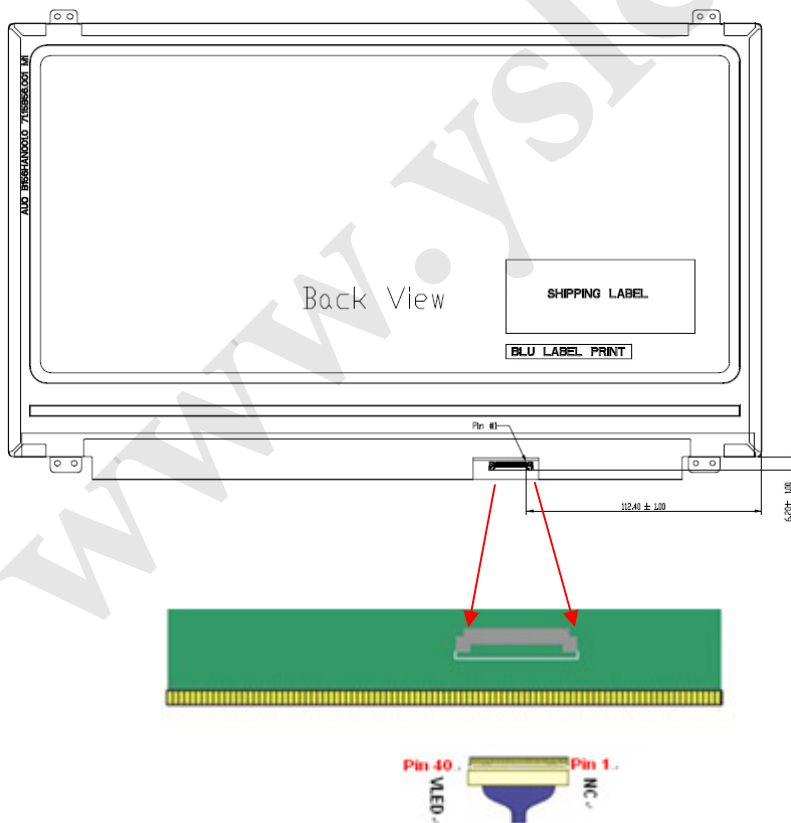

Note1 : start from right side

Note2 : Input signals shall be low or High-impedance state when VDD is off,

## 6.3 Interface Timing

### 6.3.1 Timing Characteristics

Basically, interface timings should match the 1920x1080 /60Hz manufacturing guide line timing.

Parameter	Symbol	Min.	Typ.	Max.	Unit	
Frame Rate	-	-	60	-	Hz	
Clock frequency	$1/T_{\text{Clock}}$	132	141	149.1	MHz	
Vertical Section	Period	$T_V$	1084	1110	$1080+A$	$T_{\text{Line}}$
	Active	$T_{VD}$	1080			
	Blanking	$T_{VB}$	4	30	A	
Horizontal Section	Period	$T_H$	2000	2080	$1920+B$	$T_{\text{Clock}}$
	Active	$T_{HD}$	1920			
	Blanking	$T_{HB}$	80	160	B	

**Note 1 :** The above is as optimized setting

**Note 2 :** The maximum clock frequency =  $(1920+B)*(1080+A)*60 < 149.1\text{MHz}$

**Note 3 :** Clock frequency number is for reference, real setting value refer to EDID

### 6.3.2 Timing diagram

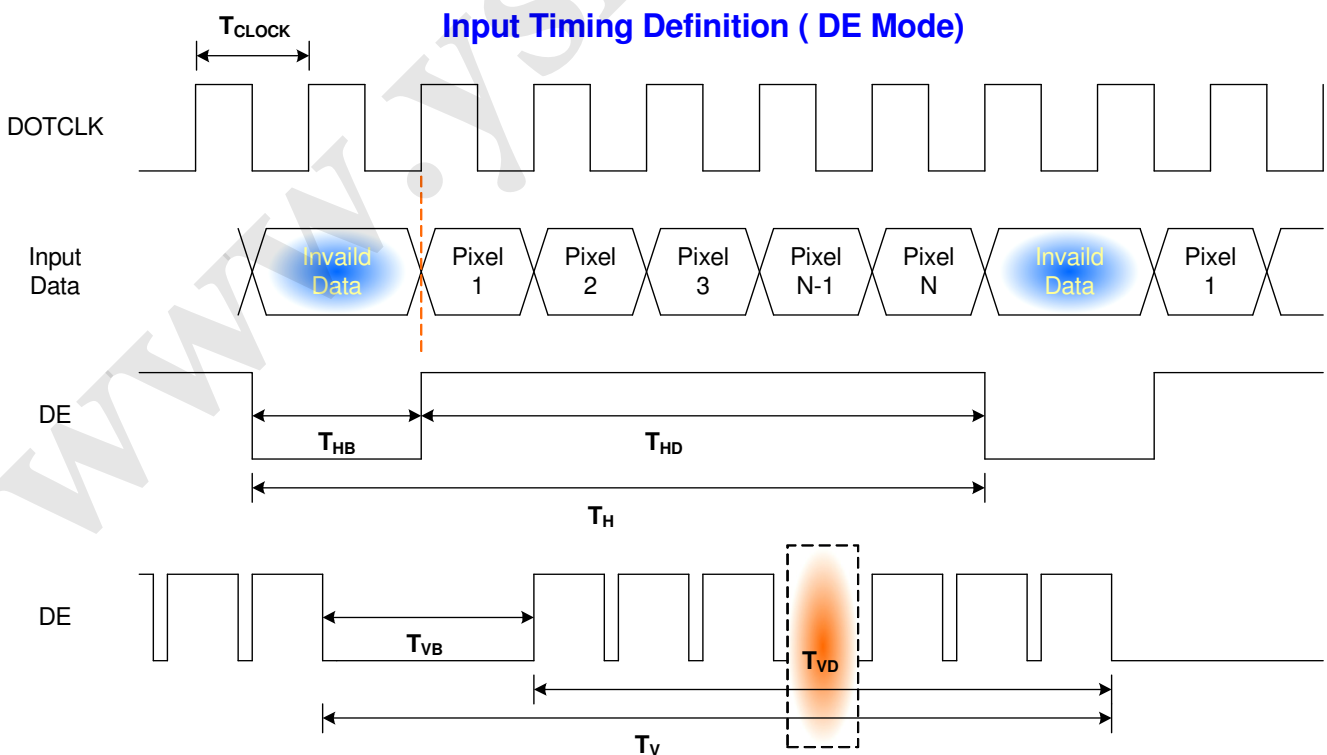

## 6.4 Power On Sequence

Power on/off sequence is as follows. Interface signals and LED on/off sequence are also shown in the chart. Signals from any system shall be Hi-Z state or low level when VDD is off

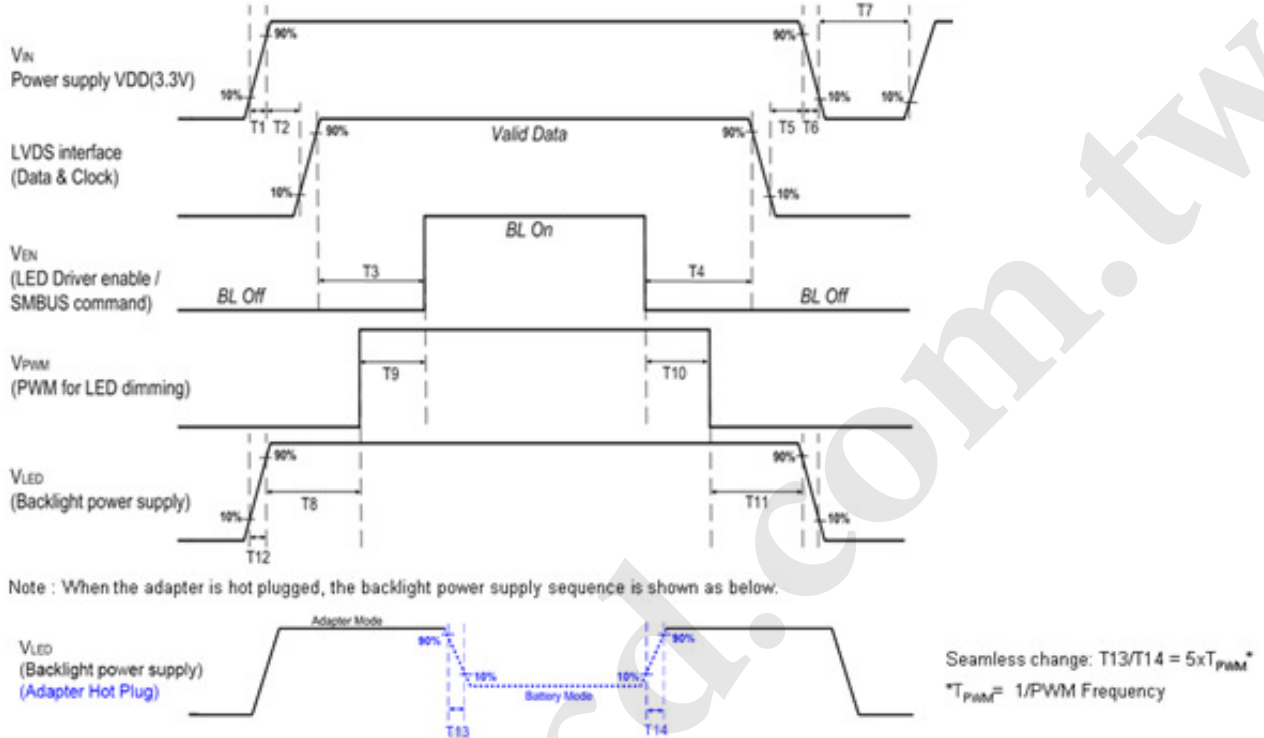

	Min (ms)	Max (ms)
T1	0.5	10
T2	0	50
T3	200	-
T4	200	-
T5	0	50
T6	0	10
T7	500	-
T8	10	-
T9	10	-
T10	10	-
T11	10	-
T12	0.5	10
T13	1*	-
T14	1*	-

Note 1: If  $T_3 < 200ms$ , the display garbage may occur. ( $T_3 > 200ms$  is recommended)

Note 2 : If  $T_1$  or  $T_{12} < 0.5ms$  , the inrush current may cause the damage of fuse. If  $T_1$  or  $T_{12} < 0.5ms$  , the inrush current  $I_{2t}$  is under typical melt of fuse Spec. , there is no mentioned problem.

## 7. Panel Reliability Test

### 7.1 Vibration Test

**Test Spec:**

- Test method: Non-Operation
- Acceleration: 1.5 G
- Frequency: 10 - 500Hz Random
- Sweep: 30 Minutes each Axis (X, Y, Z)

### 7.2 Shock Test

**Test Spec:**

- Test method: Non-Operation
- Acceleration: 220 G , Half sine wave
- Active time: 2 ms
- Pulse: X,Y,Z .one time for each side

### 7.3 Reliability Test

Items	Required Condition	Note
Temperature Humidity Bias	Ta= 40°C , 90%RH, 300h	
High Temperature Operation	Ta= 50°C , Dry, 300h	
Low Temperature Operation	Ta= 0°C , 300h	
High Temperature Storage	Ta= 60°C , 35%RH, 300h	
Low Temperature Storage	Ta= -20°C , 50%RH, 250h	
Thermal Shock Test	Ta=-20°C to 60°C , Duration at 30 min, 100 cycles	
ESD	Contact : ±8 KV Air : ±15 KV	Note 1

**Note1:** According to EN 61000-4-2 , ESD class B: Some performance degradation allowed. Self-recoverable.

No data lost, No hardware failures.

**Remark:** MTBF (Excluding the LED): 30,000 hours with a confidence level 90%



# Product Specification

AU OPTRONICS CORPORATION

## 8. Mechanical Characteristics

### 8.1 LCM Outline Dimension

#### 8.1.1 Standard Front View

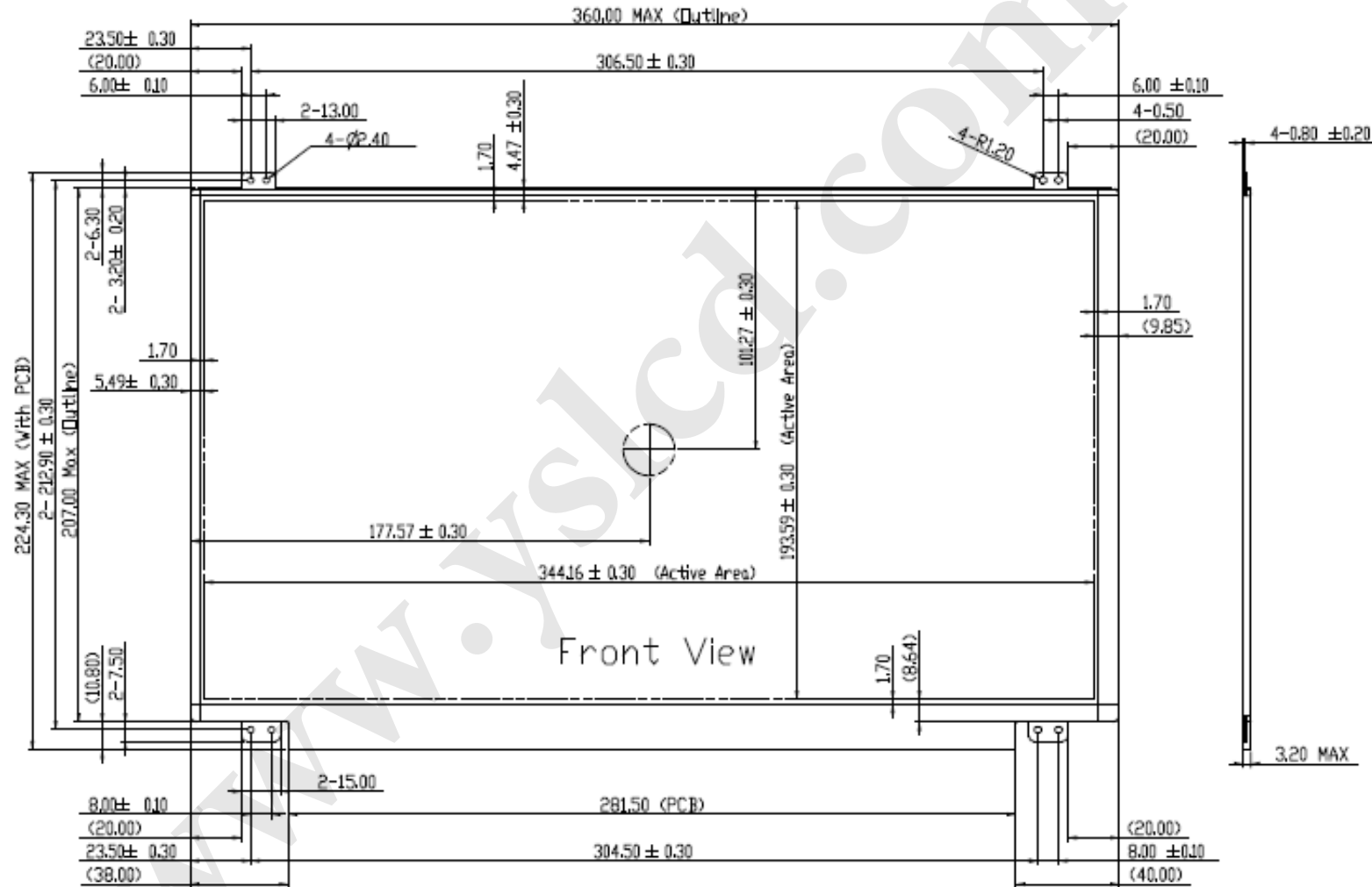



# Product Specification

AU OPTRONICS CORPORATION

## 8.1.2 Standard Back View

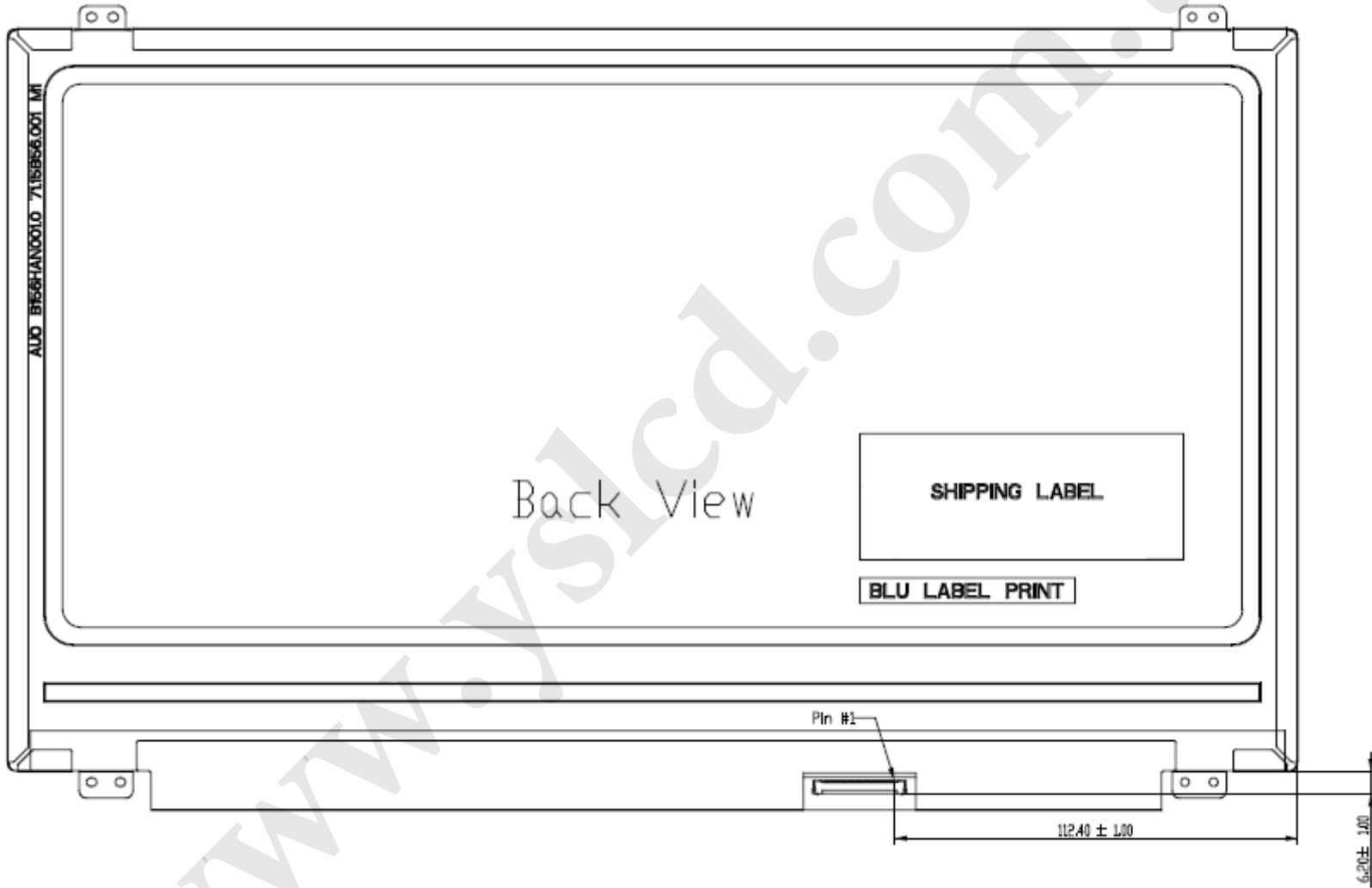



# Product Specification

AU OPTRONICS CORPORATION

## 9. Shipping and Package

### 9.1 Shipping Label Format

 *XXXXXXXXXXXX-XXXX*	<b>Manufactured YY / WW</b> <b>Model No: B156HAN01.0</b> AU Optronics MADE IN CHINA (S01)	c  US  E204356
 CT:CDFPF01XXXXXXXX	<b>H/W: 0A F/W:1</b>	 

www.yslcd.com



## 9.2 Carton Package

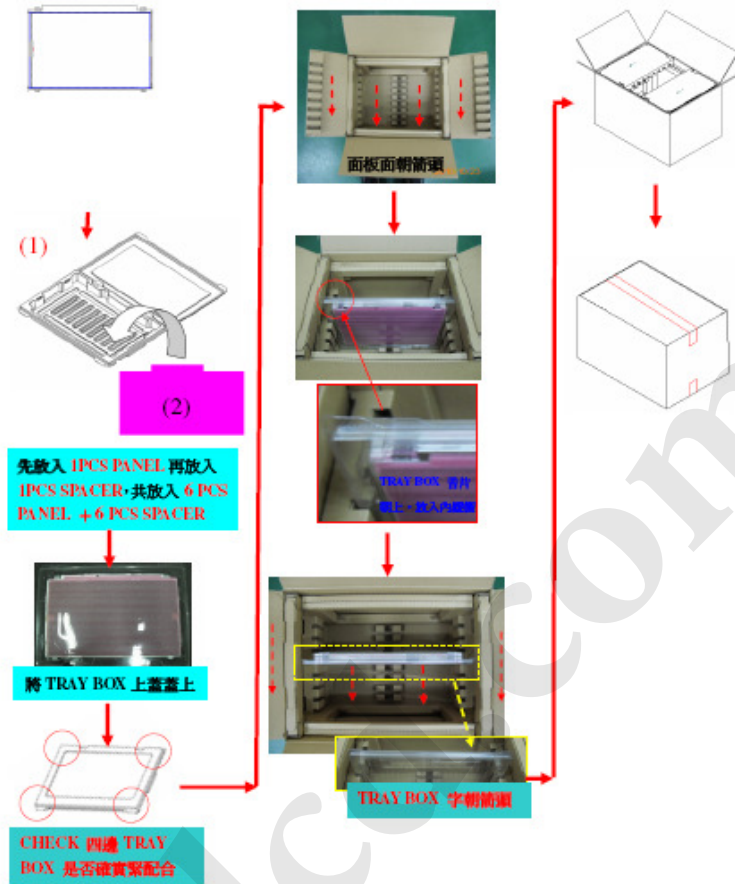

## 9.3 Shipping Package of Palletizing Sequence

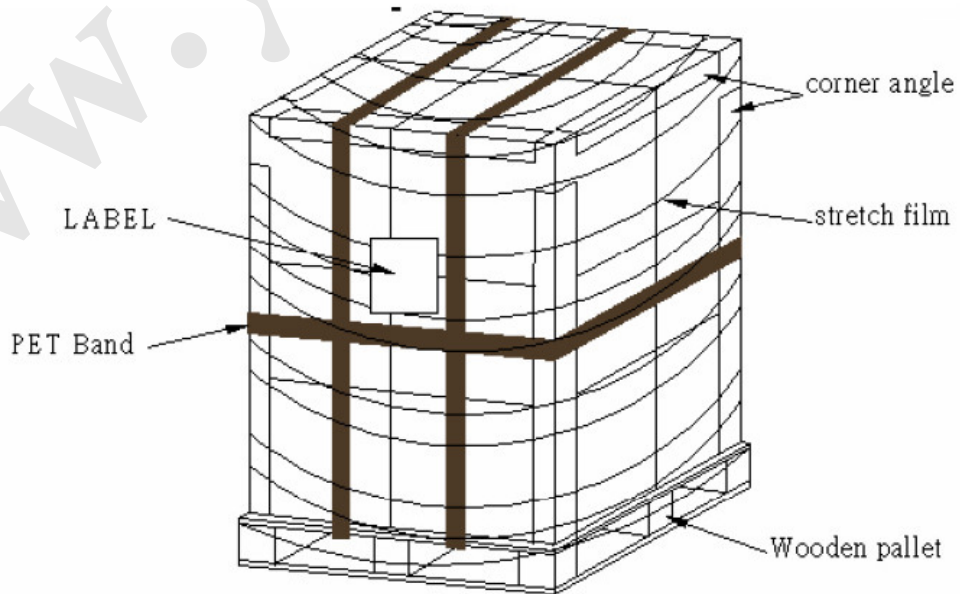



# Product Specification

AU OPTRONICS CORPORATION

## 10. Appendix: EDID Description

Address	FUNCTION	Value	Value	Value	Note
HEX		HEX	BIN	DEC	
00	Header	00	00000000	0	
01		FF	11111111	255	
02		FF	11111111	255	
03		FF	11111111	255	
04		FF	11111111	255	
05		FF	11111111	255	
06		FF	11111111	255	
07		00	00000000	0	
08	EISA Manuf. Code LSB	06	00000110	6	
09	Compressed ASCII	AF	10101111	175	
0A	Product Code	ED	11101101	237	
0B	hex, LSB first	10	00010000	16	
0C	32-bit ser #	00	00000000	0	
0D		00	00000000	0	
0E		00	00000000	0	
0F		00	00000000	0	
10	Week of manufacture	00	00000000	0	
11	Year of manufacture	16	00010110	22	
12	EDID Structure Ver.	01	00000001	1	
13	EDID revision #	04	00000100	4	
14	<b>Video input def.</b> ( <i>digital I/P, non-TMDS, CRGB</i> )	90	10010000	144	
15	<b>Max H image size</b> ( <i>rounded to cm</i> )	22	00100010	34	
16	<b>Max V image size</b> ( <i>rounded to cm</i> )	13	00010011	19	
17	<b>Display Gamma</b> ( <i>=(gamma*100)-100</i> )	78	01111000	120	
18	<b>Feature support</b> ( <i>no DPMS, Active OFF, RGB, tmg Blk#1</i> )	02	00000010	2	
19	Red/green low bits ( <b>Lower 2:2:2:2 bits</b> )	06	00000110	6	
1A	Blue/white low bits ( <b>Lower 2:2:2:2 bits</b> )	95	10010101	149	
1B	Red x ( <b>Upper 8 bits</b> )	97	10010111	151	
1C	Red y/ highER 8 bits	57	01010111	87	
1D	Green x	53	01010011	83	
1E	Green y	94	10010100	148	
1F	Blue x	26	00100110	38	
20	Blue y	1C	00011100	28	
21	White x	50	01010000	80	
22	White y	54	01010100	84	
23	Established timing 1	00	00000000	0	
24	Established timing 2	00	00000000	0	
25	Established timing 3	00	00000000	0	
26	Standard timing #1	01	00000001	1	
27		01	00000001	1	
28	Standard timing #2	01	00000001	1	



# Product Specification

AU OPTRONICS CORPORATION

29		01	00000001	1	
2A	Standard timing #3	01	00000001	1	
2B		01	00000001	1	
2C	Standard timing #4	01	00000001	1	
2D		01	00000001	1	
2E	Standard timing #5	01	00000001	1	
2F		01	00000001	1	
30	Standard timing #6	01	00000001	1	
31		01	00000001	1	
32	Standard timing #7	01	00000001	1	
33		01	00000001	1	
34	Standard timing #8	01	00000001	1	
35		01	00000001	1	
36	Pixel Clock/10000 LSB	14	00010100	20	
37	Pixel Clock/10000 USB	37	00110111	55	
38	Horz active <b>Lower 8bits</b>	80	10000000	128	
39	Horz blanking <b>Lower 8bits</b>	C0	11000000	192	
3A	HorzAct:HorzBlnk <b>Upper 4:4 bits</b>	70	01110000	112	
3B	Vertical Active <b>Lower 8bits</b>	38	00111000	56	
3C	Vertical Blanking <b>Lower 8bits</b>	20	00100000	32	
3D	Vert Act : Vertical Blanking <b>(upper 4:4 bit)</b>	40	01000000	64	
3E	HorzSync. Offset	30	00110000	48	
3F	HorzSync.Width	64	01100100	100	
40	VertSync.Offset : VertSync.Width	8E	10001110	142	
41	Horz&Vert Sync Offset/Width <b>Upper 2bits</b>	00	00000000	0	
42	Horizontal Image Size <b>Lower 8bits</b>	58	01011000	88	
43	Vertical Image Size <b>Lower 8bits</b>	C1	11000001	193	
44	Horizontal & Vertical Image Size <b>(upper 4:4 bits)</b>	10	00010000	16	
45	Horizontal Border <i>(zero for internal LCD)</i>	00	00000000	0	
46	Vertical Border <i>(zero for internal LCD)</i>	00	00000000	0	
47	Signal <i>(non-intr, norm, no stereo, sep sync, neg pol)</i>	18	00011000	24	
48	Pixel Clock/10,000 (LSB)	B8	10111000	184	40Hz frame rate
49	Pixel Clock/10,000 (MSB)	24	00100100	36	
4A	Horizontal Addressable Pixels, lower 8 bits	80	10000000	128	
4B	Horizontal Blanking Pixels, lower 8 bits	C0	11000000	192	
4C	H Pixels, upper nibble : H Blanking, upper nibble	70	01110000	112	
4D	Vertical Addressable Lines, lower 8 bits	38	00111000	56	
4E	Vertical Blanking Lines, lower 8 bits	20	00100000	32	
4F	V lines, upper nibble : V blanking, upper nibble	40	01000000	64	
50	Horizontal Front Porch, lower 8 bits	30	00110000	48	
51	Horizontal Sync Pulse, lower 8 bits	64	01100100	100	
52	V Front Porch, lower nibble : V Sync Pulse, lower nibble	8E	10001110	142	
53	VFP, 2 bits: VSP 2 bits: HFP 2 bits: HFP 2 bits	00	00000000	0	
54	Horizontal Image Size in mm, lower 8 bits	58	01011000	88	
55	Vertical Image Size in mm, lower 8 bits	C1	11000001	193	
56	H Image Size, upper nibble : V Image Size, upper nibble	10	00010000	16	
57	Horizontal Border	00	00000000	0	



# Product Specification

AU OPTRONICS CORPORATION

58	Vertical Border	00	00000000	0	
59	Bit Encode Sync Information	18	00011000	24	
5A	DC	00	00000000	0	nVDPS Reserved 00
5B	HTOTAL	00	00000000	0	
5C	HA	00	00000000	0	
5D	HBL	00	00000000	0	
5E	HFP	00	00000000	0	
5F	HFPe	00	00000000	0	
60	HBP	00	00000000	0	
61	HB	00	00000000	0	
62	HSO	00	00000000	0	
63	HS	00	00000000	0	
64	VTOTAL	00	00000000	0	
65	VA	00	00000000	0	
66	VBL	00	00000000	0	
67	VFP	00	00000000	0	
68	VBP	00	00000000	0	
69	VB	00	00000000	0	
6A	VSO	00	00000000	0	
6B	VS	00	00000000	0	
6C	Detail Timing Description #4	00	00000000	0	Header
6D	Flag	00	00000000	0	
6E	Reserved	00	00000000	0	
6F	For Brightness Table and Power Consumption	02	00000010	2	
70	Flag	00	00000000	0	Brightness Table
71	PWM % [7:0] @ Step 0	0C	00001100	12	
72	PWM % [7:0] @ Step 5	33	00110011	51	
73	PWM % [7:0] @ Step 10	F9	11111001	249	
74	Nits [7:0] @ Step 0	0A	00001010	10	
75	Nits [7:0] @ Step 5	3C	00111100	60	
76	Nits [7:0] @ Step 10	64	01100100	100	
77	Panel Electronics Power @ 32x32 Chess Pattern =	1F	00011111	31	Power Consumption
78	Backlight Power @ 60 nits =	14	00010100	20	
79	Backlight Power @ Step 10 =	22	00100010	34	
7A	Nits @ 100% PWM Duty =	6E	01101110	110	
7B	Flag	20	00100000	32	
7C	Flag	20	00100000	32	
7D	Flag	20	00100000	32	
7E	Extension Flag	00	00000000	0	
7F	Checksum	10	00010000	16	